

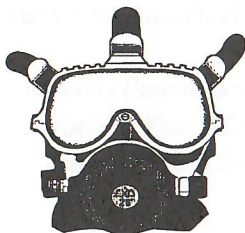


Diving With The **EXO-26**® Full Face Mask

# Diving With The **EXO-26**® Full Face Mask

# Diving with the EXO-26<sup>®</sup> Full Face Mask

*a manual for sport,  
technical, public safety,  
and scientific divers*



by  
**Steven M. Barsky**



**PADI**

**Albrecht Salm**  
Master Scuba Diver Trainer  
PADI MSDT # 33913

*EXO-26<sup>®</sup>, Dive Control System<sup>®</sup>, DCS-2<sup>®</sup>, DCS-3<sup>®</sup>, and SuperLite-17<sup>®</sup>  
are all registered trademarks of Diving Systems International.*



© 1994 Team Vision, Inc.

Photography by Steven M. Barsky, unless otherwise noted.

Copyright © 1994 by Team Vision, Inc.

All Rights Reserved

No part of this book may be reproduced, stored in a retrieval system, or transmitted in any form or by any means; electronic, mechanical, photocopying, microfilming, recording, or otherwise; without written permission from the publisher, except by a reviewer who may quote brief passages in a review with appropriate credit.

FIRST EDITION

*Designed by Teresa D. Hawkes/Hawkemoon Enterprises*

ISBN 1-884843-00-X

Composed and printed in the United States of America.

Team Vision, Inc.  
3424 Carlton Ave.  
Ft. Collins, CO; 80525 USA

## Warning

All diving presents an element of risk. Even when you do everything right it is still possible to have a diving accident due to circumstances beyond your control. The environment and even your own body can lead to situations that result in a diving accident or fatality.

Full face masks can solve many diving problems, but like any piece of diving equipment they represent a trade-off. You need to have training to use this type of specialized diving equipment. Your training must be updated at least annually and you must maintain proficiency in the skills associated with using a full face mask.

Your full face mask must be serviced at least once a year at a minimum. An accurate log of any work performed on your mask must be maintained.

# Table of Contents

Chapter	Page
<b>Chapter 1: Introduction to Full Face Masks</b> .....	7
What is a Full Face Mask? .....	8
What About "Half-Masks"? .....	10
Selecting a Full Face Mask .....	10
Applications for Full Face Masks .....	13
Public Safety Diving .....	13
Polluted Water Diving .....	14
Ice Diving .....	15
Deep Diving/Technical Diving .....	15
Scientific Diving .....	16
Recreational Diving .....	16
Putting things in perspective .....	17
<b>Chapter 2: Diving Modes with Full Face Masks</b> .....	19
The EXO-26® in the Scuba Mode .....	20
The EXO-26® in the Tethered Scuba Mode .....	22
The EXO-26® in the Surface Supplied Mode .....	26
<b>Chapter 3: Safety Considerations for Full Face</b>	
<b>Mask Diving</b> .....	35
Loss of Communications .....	36
Broken Face Port .....	37
Sharing Air While Using the EXO-26® .....	38
Problems with In-Water Decompression on Oxygen .....	38
Risk of Entanglement .....	41
<b>Chapter 4: The EXO-26® Full Face Mask</b> .....	43
Breathing System .....	43
Communications .....	46
Mask Frame and Face Seal .....	49
Accessories .....	50
EXO-26® Hood .....	50
Equalizing Device .....	51
Manifold Block .....	51
Head Protector .....	53
Tool Kit .....	55
Mask Carrying Bag .....	55

## Chapter 5: Scuba Diving with the EXO-26®

<b>Full Face Mask</b> .....	59
Setting Up the Mask for Use with Scuba .....	60
Setting Up for Wireless Communications .....	63
Mask Preparation .....	70
Setting Up the Mask for Tethered Scuba Diving .....	72
Donning and Adjusting the Mask .....	73
Entering the Water .....	75
Equalizing .....	75
Surface Swimming .....	76
Underwater with the EXO-26® .....	76
Emergency Procedures .....	78
Post Dive .....	83

## Chapter 6: Surface Supplied Diving with the EXO-26® Full Face Mask

<b>Cost Factors</b> .....	88
Selecting Equipment for Surface Supplied Diving .....	88
The Surface Supplied Diving Team .....	93
Setting up for surface supplied diving operations .....	96
Dressing in for the Dive .....	100
Diving Procedures During a Surface Supplied Dive .....	101
Decompression Diving .....	104
Emergency Procedures .....	105
Post-Dive System Breakdown .....	108

## Chapter 7: Maintenance of the EXO-26® Full Face

<b>Mask</b> .....	109
Communications Module Removal and Replacement .....	110
Rinsing Procedures .....	114
Proper Storage .....	116

## Chapter 8: Field Repairs for the EXO-26® Full Face

<b>Mask</b> .....	117
Communications Components .....	118
Replacing the Spider .....	119

<b>Glossary</b> .....	121
-----------------------	-----

<b>Bibliography</b> .....	127
---------------------------	-----



# Chapter 1

## Introduction to Full Face Masks



**Fig. 1.1 Full face masks like the EXO-26® are designed to cover the entire face, but not the head.**

Diving with a full face mask is a unique experience. It is quite different in many ways from diving with an ordinary scuba regulator and face mask. Like any piece of diving equipment, the full face mask is a compromise designed to achieve a specific set of goals. Full face masks have certain advantages and disadvantages that we will discuss through the course of this book.

### What is a full face mask?

A full face mask is a diving mask that covers the eyes, nose, and mouth. Because it covers the entire face, and the breathing system is part of the mask, the mask must make a watertight seal on the face. The watertight seal has two functions. First, it must seal properly to allow

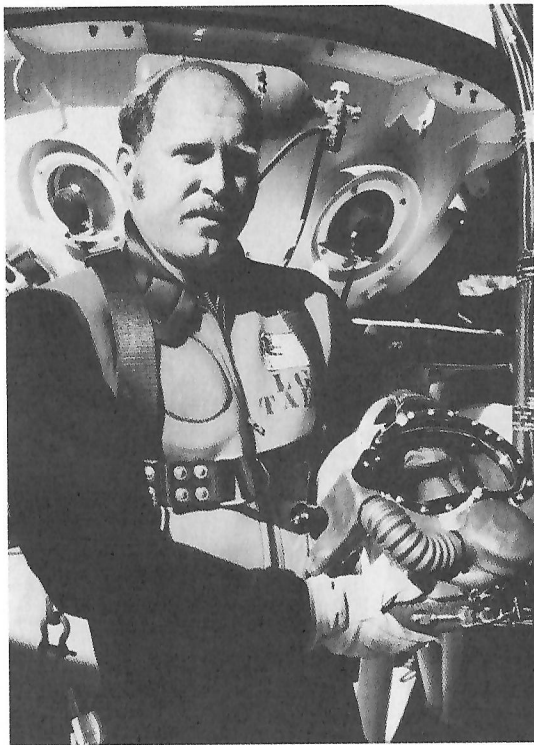


Fig. 1.2 Diving helmets are designed to cover a diver's entire head and to keep it totally dry. (© Diving Systems International. All rights reserved.)

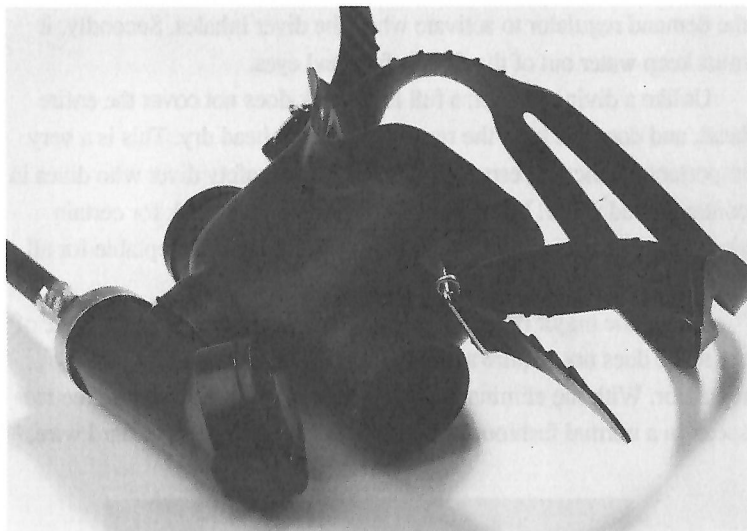
the demand regulator to activate when the diver inhales. Secondly, it must keep water out of the diver's face and eyes.

Unlike a diving helmet, a full face mask does not cover the entire head, and does not keep the rest of the diver's head dry. This is a very important distinction, especially for the public safety diver who dives in contaminated water. It is possible to use a full face mask for certain situations in contaminated water diving, but it is *not* acceptable for all circumstances.

One of the major benefits in using a full face mask is that the use of the mask does not require a mouthpiece like a conventional scuba regulator. With the elimination of the mouthpiece, the diver is free to speak in a normal fashion. With the addition of wireless or hard wire



Fig. 1.3 The addition of wireless communications allows divers wearing full face masks to communicate with each other.



**Fig. 1.4 Half-masks are not nearly as convenient to use as full face masks.**

communications systems, most full face masks provide excellent communications.

### **What about “half-masks”?**

Some divers have tried to get around using a full face mask by using a half-mask that covers the mouth and jaw. The purpose of the half-mask is to free you of a mouthpiece and permit communications.

There are several problems with half-masks. Half-masks must seal on the narrow space of your upper lip and share that space with your scuba mask. This can make it difficult to get an effective seal. In addition, because the half-mask separates your nose and mouth into isolated chambers, it degrades the quality of your speech. Half-masks are also not considered acceptable for contaminated water diving.

### **Selecting a full face mask**

There are many factors that must be taken under consideration when you select a full face mask. First, the breathing system should be of a design that provides an excellent flow of gas, whether you are a professional diver or an avid technical diver.

The breathing system in the mask should eliminate as much “dead” air space as possible. Dead air space is defined as those areas inside the mask where no gas exchange takes place. When this happens, carbon dioxide ( $\text{CO}_2$ ) can build up inside the mask and interfere with normal breathing. Carbon dioxide “triggers” breathing and the more carbon dioxide that builds up in the system, the more rapid your breathing will become. If you inhale too much carbon dioxide you will reach a point where you will not be able to breathe for comfort. Better full face masks have minimal dead air space to help avoid this problem.

Part of the breathing system of the mask is the design of the space for your nose and mouth. In some masks, the nose and mouth will be isolated from the rest of the mask by what is known as an “oral/nasal” mask, or cavity. The primary function of this compartment is to help reduce carbon dioxide, but it also has a big influence on the speech characteristics and clarity of your communications. In the EXO-26®, the smooth flow of gas through the mask (laminar flow) helps to “flush” the mask out with each breath.

Another important feature of the breathing system of the full face mask is some provision for defogging the lens of the mask. Different masks handle this problem in different ways, but in a full face mask it is usually not practical or desirable to allow water to enter the mask to defog the lens underwater. In the rare event water enters the mask, the mask must be capable of rapidly purging the water from the breathing system.

The sealing system of the mask should work comfortably over a wide range of faces. It should seal comfortably over both beards and smooth faces. The face seal should be designed so that it is comfortable to wear for long hours in the water.

All divers must equalize the pressure in their ears as they dive. Better full face masks have some mechanism for equalizing this pressure. Some masks provide nose pockets, while others use special devices. The EXO-26® has both capabilities.

The lens or viewport of the mask should be designed for maximum visibility. It should be made of a material that will resist breaking. If it is made of glass, then it must be tempered glass that will not produce dangerous shards if it breaks.

The head strap on a full face mask is usually referred to as a head harness or “spider”. The design of the spider should be such that it is large and rugged. It should be easy to tighten or loosen the spider even if you are wearing heavy gloves or mitts.

The frame of the mask provides an attachment point for the straps, the lens, and the regulator. It should be made of a durable material that won't crack under impact or in cold weather. The frame, in combination with the spider and face seal must also accommodate some means of mounting the earphones used for communications.

Since every piece of equipment requires periodic maintenance, another major consideration is the complexity of the mask. The simpler the mask is to maintain, the more tasks you will be able to complete



**Fig. 1.5** The EXO-26® can be used for surface supplied diving as well as with scuba.

yourself. In addition, your maintenance bills will usually be less expensive on a simpler mask.

Above all, before you purchase any full face mask, you should dive with it to see if it is comfortable on your face and meets your needs.

### **Applications for full face masks**

There are many applications for full face masks in a wide variety of diving situations. In addition to providing communications and protection from contaminated water, full face masks also offer more warmth, and additional safety in the event a diver blacks out underwater.

The most important applications for full face masks include polluted water diving, public safety diving, deep and technical diving, scientific diving, and ice diving. In addition, some sport divers are beginning to see the benefits of using full face masks and are making the switch to this type of equipment.

### **Public Safety Diving**

Public safety diving is an excellent application for the full face mask. Since public safety diving involves the use of systematic search patterns underwater, communications are a tremendous aid to this type of work.

Public safety divers use full face masks for their work in two primary modes. One of the most popular is what is known as “tethered scuba.” In tethered scuba diving, the diver wears conventional scuba gear, except that rather than an ordinary face mask and regulator, a full face mask is used instead. In this case, the tether is actually a search line with a communications wire embedded inside it. The wire connects the full face mask to a topside communications box.

The other mode for using the full face mask for public safety diving is surface supplied. Surface supplied diving involves the use of a topside air supply and an umbilical to carry the air to the diver. The umbilical is composed of an air supply hose, a communications wire, and a hose for sensing the depth by measuring hydrostatic pressure. The topside air supply can be either a low pressure air compressor or a bank of high pressure cylinders with a pressure reducing regulator. Surface supplied diving has many advantages over using the full face mask with scuba. It



also has certain disadvantages. The pros and cons of surface supplied diving will be covered in *Chapter 2* of this book.

The EXO-26® may be used for either full face mask diving with wireless communications, tethered scuba, or surface supplied diving. It works equally well in all three applications.

### Polluted Water Diving

Polluted water diving is one of the most critical applications for the full face mask. In polluted water diving, the objective is to keep the diver totally isolated from the surrounding water. The full face mask can only accomplish this when it is used in conjunction with a dry suit that has an attached latex dry hood.

The full face mask is a good solution for contaminated water diving when the objective is to dive in an environment where a contaminant is present that will *not* produce long term disability or death. The advantages to a full face mask for this type of diving are its light weight, its low cost, and its relative ease of use. The disadvantage of using a full face mask for contaminated water diving is the risk of the mask becoming dislodged from the diver's face. In situations where the contaminants may cause death or long term disability, a diving helmet, like the SuperLite-17®, is a better choice.

The EXO-26® does *not* have a redundant exhaust mechanism, or "double exhaust." On the positive side, the inhalation and exhaust mechanisms in the EXO-26® are isolated from each other. The double exhaust is preferred for diving operations in contaminated water. The double exhaust acts as an additional barrier against any contaminants that enter the breathing system. Many search and rescue teams use the EXO-26® successfully for operations in polluted water and this is acceptable, as long as you realize this limitation of the mask.

Polluted water diving is a highly specialized type of diving that requires specialized training and equipment. Divers who do this type of work should requalify for this type of diving on an annual basis and train monthly. Polluted water diving is especially hazardous.

For more comprehensive information on polluted water diving read *Diving in High-Risk Environments*, also by Steve Barsky. The book is available from Dive Rescue International.



**Fig. 1.6** In some contaminated water situations, a helmet like the SuperLite-17® may be the best choice for diving operations.

---

### Ice Diving

The full face mask is an excellent piece of equipment for ice diving. When used in conjunction with a dry suit, the diver can be kept totally dry and has tremendous insulation. In addition, most full face masks are less prone to freezing than ordinary scuba regulators. Different regulator designs handle this problem through different approaches.

The EXO-26® is a superior piece of equipment for ice diving. It has been successfully used in the Antarctic by many organizations.

### Deep Diving/Technical Diving

Many divers engaged in deep or technical diving are using full face masks for a variety of reasons. Although the majority of technical divers

prefer to dive solo, a full face mask equipped with communications does provide them with the ability to call for assistance when other divers are similarly equipped. It is also possible, with the correct rigging, for two divers with full face masks to share a single air supply.

In the event of a blackout underwater, a full face mask also offers the diver a better chance of survival than conventional scuba. With the full face mask, there is no way for the diver to lose his mouthpiece, like he might with an ordinary scuba regulator.

Through the use of a manifold, the diver wearing a full face mask can switch gases at depth without the need to remove the full face mask. This is a better alternative than changing scuba regulators to access different gas mixtures.

### **Scientific Diving**

Many scientific divers use full face masks in the course of their scientific work. The primary benefit to them is the ability to communicate their observations to a data recorder topside, or to capture them on a tape recorder.

In many cases the use of the full face mask has cut hundreds of hours of bottom time and increased productivity for scientific divers. It is far more productive to use voice communications and record data topside than it is to try to record data on a slate underwater.

One of the leading agencies that makes regular use of full face masks is the National Park Service. They have used full face masks with surface supplied equipment for 10 years in their Kelp Forest Monitoring Project at California's Channel Islands. In addition, their Submerged Cultural Resources Unit has used full face masks extensively in their surveys of sunken ships from the Great Lakes to the far Pacific.

### **Recreational Diving**

Many recreational divers have found full face masks with communications have enhanced their diving enjoyment. In particular, avid underwater photographers have found the use of communications to be quite helpful in directing their underwater models. It is far easier to give verbal directions to a model underwater than it is to try to communicate with hand signals.

### **Putting things in perspective**

Using a full face mask is not the answer to every diving situation. However, in many circumstances a full face mask like the EXO-26® can increase safety and productivity. The full face mask is a tool that should be selected for the appropriate situations. In this book we will explore which situations are appropriate for full face masks and which ones are not.



# Chapter 2

## Diving Modes with Full Face Masks



**Fig. 2.1** If you dive with a partner, you have some responsibility for that person underwater.

---

As mentioned in Chapter 1, there are several different ways to use full face masks. One of the most common modes, for the lightweight mask like the EXO-26®, is to use the mask as a free swimming scuba diver. This can be simple, if you are a sport diver, or more complex if you are a technical diver. Slightly more restrictive is to use the mask in

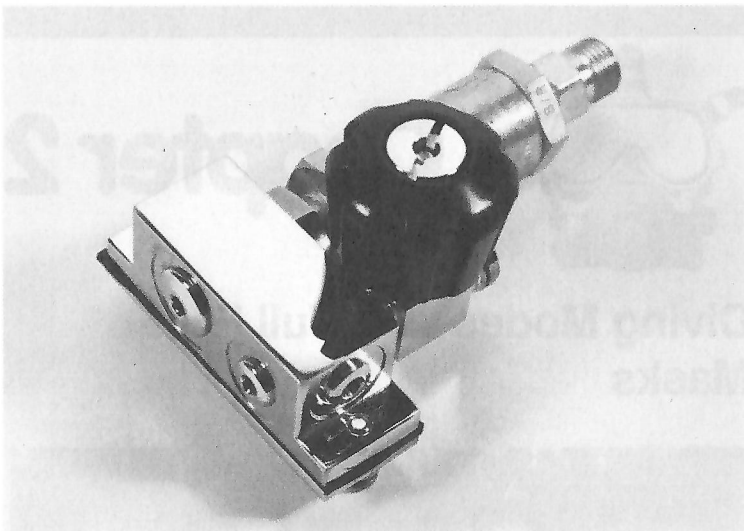


Fig. 2.2 A simple manifold (bail-out) block. (© Diving Systems International. All rights reserved.)

the tethered scuba mode, with a hard-wire communication line that connects the diver to the surface. The surface supplied mode of diving is the most sophisticated method of using the mask, involves more personnel, and is one of the most expensive modes.

### The EXO-26® in the Scuba Mode

There are many advantages to using the EXO-26® on scuba, and the majority of them are the same as scuba itself. First, the scuba diver has the greatest mobility of any type of diver. You can swim over, under, and around obstacles. Provided you are not in an overhead environment, and have no decompression obligation, you can make a direct ascent to the surface in an emergency situation. Of course, a precautionary decompression stop is always recommended.

As a free swimming diver the chances of entanglement are usually somewhat less than they are for the tethered scuba diver, or the surface supplied diver. Without a wire or an umbilical trailing behind him, the free swimming EXO-26® diver is free to go where he wants to go.

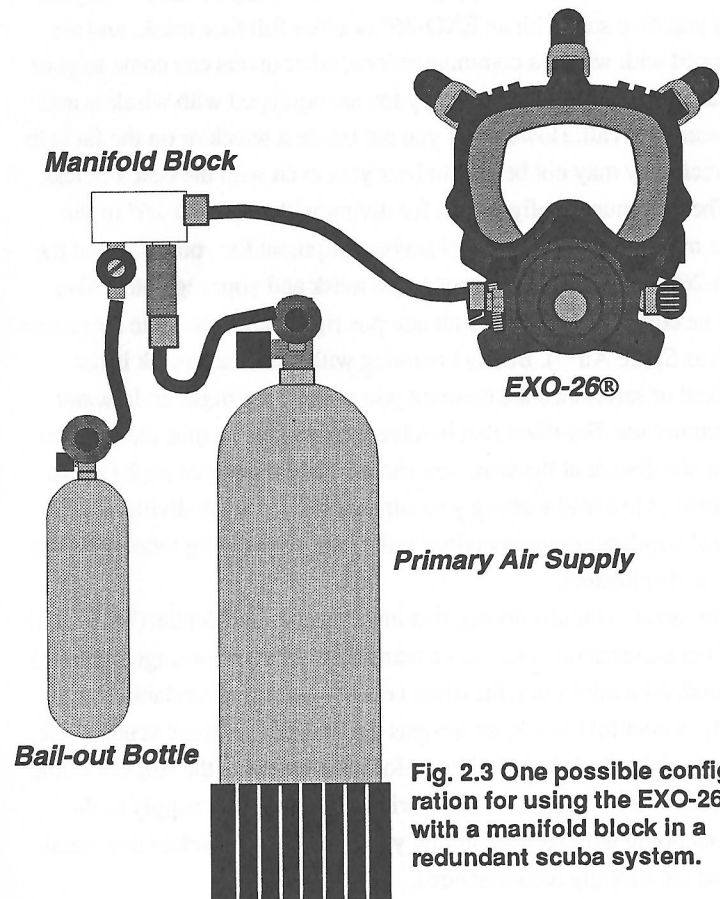


Fig. 2.3 One possible configuration for using the EXO-26® with a manifold block in a redundant scuba system.

If you scuba dive with a partner, you still have some dependency upon that person for *your* safety, as well as responsibility for *their* safety. If you dive solo, you are free of dependency from other people, although other people at the dive site will usually assume some responsibility for your safety.

All the advantages of using the EXO-26® as a free swimming scuba diver are mirrored in the disadvantages. The mobility that works for you can also work against you, particularly if there is a strong current or heavy sea conditions. While your chances of entanglement may be somewhat less, if you do become entangled while on scuba the conse-

quences can be far more serious than if you are using surface supplied. As a scuba diver your air supply is limited to what you carry with you.

If you dive solo with an EXO-26® or other full face mask, and are equipped with wireless communications, other divers can come to your assistance if needed, provided they too are equipped with wireless and can hear your call. However, if you are inside a wreck or on the far side of a reef, they may not be able to hear you, even with the best wireless.

The minimum configuration for diving with the EXO-26® in the scuba mode includes all normal scuba equipment for your area, but the EXO-26® is substituted for your scuba mask and your regulator. You must be equipped with either an octopus rig or other alternate air source (such as Spare Air™). Buddy breathing with a full face mask is not practical or safe, since the moment you remove the mask underwater you cannot see. For dives that involve long surface swims, either at the end of the dive or at the start, you should carry a separate scuba mask and snorkel to avoid wasting your air supply. If you are diving with a partner, wireless communications will make your diving more efficient, safer, and enjoyable.

For technical scuba diving, that involves extreme depths (below 130 FSW) or penetration dives, more complex equipment arrangements are required. At a minimum, the diver needs to wear a redundant air supply, a manifold block, an octopus rig, and carry a spare scuba mask. The manifold block is a small manifold that connects the bail-out bottle to the EXO-26®. It allows you to switch from the main supply to the bail-out bottle without interrupting your breathing. Wireless communications are strongly recommended.

If the diver is using scuba with mixed gas, then even more complex manifold arrangements are required. The manifold must be capable of switching between multiple gas supplies. The handles on the manifold must be coded by shape, color, and position so that there is no mistake possible regarding which gas supply is which.

### The EXO-26® in the Tethered Scuba Mode

Tethered scuba is a very popular method of diving with the EXO-26® for search and rescue diving. It has most of the advantages of scuba with the additional advantages of hard wire communications.

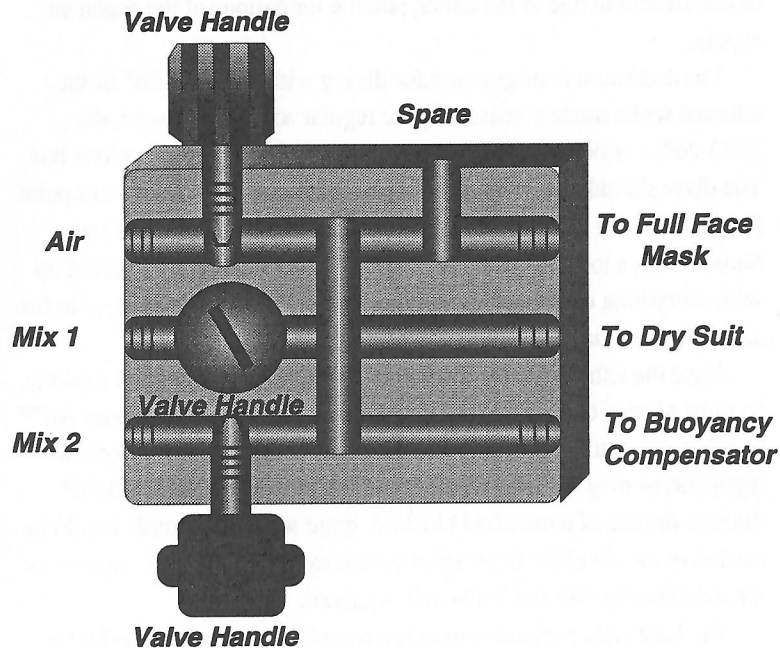


Fig. 2.4 A possible manifold for use with mixed gas scuba.

The diver's tether serves a triple purpose role. First, it provides a search line for conducting organized search patterns. Secondly, it provides a direct link between the surface and the diver. Finally, it provides the hard wire communications contact. In the event the diver becomes entangled, he can disconnect the wire (provided the connector is designed for this), clear it, and reconnect it underwater, or return to the surface to reconnect the wire. To do this, the connector must be properly attached to the mask in a position where the diver can find it if needed.

The advantages of tethered scuba are the simplicity of scuba equipment, the improved communications provided by a hard wire system, and the ability to disconnect your tether in the event of entanglement. The disadvantages of tethered scuba include the higher risk of entanglement due to the tether, and the limitations of the scuba air supply.

The minimum configuration for diving with the EXO-26® in the tethered scuba mode consists of your regular scuba equipment, the EXO-26®, a tether with connectors, and a topside communications box. The diver should also wear some type of harness as an attachment point for the tether. In most situations, the tethered scuba diver dives by himself with a topside “standby diver.” The standby diver is geared up with everything on except his full face mask. He is prepared to go to the aid of the diver in the water in the event of an emergency.

Since the tethered scuba diver does not normally work with a buddy, he must always carry a true independent air source, such as Spare Air™ or a bail-out bottle. The bail-out bottle may be rigged with a separate regulator, or may be tied into the breathing system for the EXO-26® through the use of a manifold block. A spare scuba face mask should be carried in the event the diver must switch to the Spare Air™ system or the independent bail-out bottle and regulator.

The hard wire communications provided by tethered scuba diving are generally superior in reliability to wireless communications. They are not subject to interference from wrecks, marine life, thermoclines, reefs, or other physical features of the underwater environment. The systems are quite simple to use and maintain. The communications system includes the topside box, connectors, the wire, and the EXO-26®. If you order a new EXO-26® to be used with communications you must be sure to order the mask with a communications module. The standard (basic) mask does not come equipped with either microphone or earphones, but these are available as options.

The wire itself is usually a heavy wire with a thermoplastic coating and some type of inner jacket. Surplus military wire with a plastic outer coating and a metal jacket underneath has been popular for many years. This type of wire is usually referred to as “Spiral Four Wire.” Newer comm wires have an extremely rugged plastic coating that eliminates the need for the metal jacket.

Another communications wire option is the “comm rope.” This is a 100% Kermantle Nylon braid safety rope with a 5800 pound test strength. Embedded in the rope is a four conductor 24 gauge shielded communication cable. This is an excellent piece of gear, especially for tethered scuba.

In tethered scuba diving and in surface supplied diving you can make the connection between the tether and the mask with either waterproof connectors or bare wires. Bare wires are the least recommended method of making this connection. The biggest drawback of bare wire systems is that if you are diving in salt water there is nothing to prevent water from working its way up inside the jacket and causing internal corrosion of the wire. In addition, there is some electrolysis between the wires since they are exposed to salt water with a current running through them where they connect to the mask. Bare wire systems need to be periodically cut back to expose bright shiny wire for a good connection. Eventually you will end up losing enough of your wire that it becomes unusable.

Communications systems are either two wire or four wire systems. In a two wire system only one person can speak at a time. For topside to speak to the diver, the manifold operator must push a button. This is known as a “push-to-talk” system. The advantage of a push-to-talk, two wire system is that it is generally less expensive than a four wire system. The disadvantage is that topside can’t hear the diver when they are transmitting to the diver. If more than one diver is connected to a two wire system the divers cannot hear each other unless the system is equipped with what is known as a “cross-talk” switch. This can be very confusing.

In a four wire communications system, both topside and the diver can speak and hear each other at the same time. This type of system is also known as a “round-robin” system. These systems are more expensive and generally require a bit more maintenance. They usually cost just under \$1000.00. Four wire communications systems also require special underwater connectors. They cannot be used with bare wire systems.

Air diving communications systems are manufactured by companies like Dive Rescue Int’l., Diving Systems Int’l., Aqua Tech, Ocean Technology Systems, Dive Comm, and Helle Engineering.

## The EXO-26® in the Surface Supplied Mode

Surface supplied diving is a diving mode where all the diver's breathing gas is supplied from topside. In surface supplied diving, the breathing gas is supplied to the diver by a hose or "umbilical". The umbilical also may have other hoses or cables attached to it.

There are numerous advantages to surface supplied diving that make it an excellent choice for many diving operations. First, you have the benefit of an unlimited air supply. With a surface supplied diving system, you can theoretically stay underwater forever. Of course, in reality, there are comfort, thermal, and decompression limits. For deep technical diving, a surface supplied rig relieves the diver of the need to carry numerous stage bottles. It is also safer to have a continuous gas supply from one source than to switch mouthpieces several times during the dive underwater.

The second big advantage to surface supplied diving is that you have hard wire communications. While wireless is good, it is not as reliable under all situations as hard wire. The hard wire system can be the same as any of those that would be used for tethered scuba diving.

Surface supplied diving also provides several options for a redundant air supply. The bail-out bottle is just one option, and a second will be explained shortly.

For divers using mixed gas, surface supplied diving is the best method of controlling the mix to the diver. It is safer to allow topside to control the gas mix, than to have a diver switching gases on scuba in low light where it is difficult to see and things often must be done by feel.

Polluted water diving is much safer when conducted with a full coverage helmet and surface supplied equipment. There is less chance for the diver to be exposed to contaminants when diving with a properly equipped surface supplied rig.

The biggest disadvantage of surface supplied diving is the decrease in mobility due to the umbilical. From an umbilical management standpoint, surface supplied diving is impractical for long cave penetrations. The longest umbilicals used on most commercial diving jobs do not exceed 600 feet, although commercial divers have done internal pipeline dives of up to 1800 feet.

Entanglement is a disadvantage in both tethered scuba and surface supplied diving. However, entanglement is a less serious problem for the surface supplied diver since he has an unlimited air supply.

The minimum system configuration for surface supplied diving consists of the following items:

- **Topside air supply:** This can be either a low pressure compressor or a simple, single diver air manifold box used with scuba cylinders. You can also use combinations of these breathing air/gas sources.
- **Communications System:** A single diver communications box provides the ability for the diver to speak to topside and topside to speak to the diver.
- **Umbilical:** The diver's hose or umbilical consists of a communications wire and connectors, a breathing air supply hose with

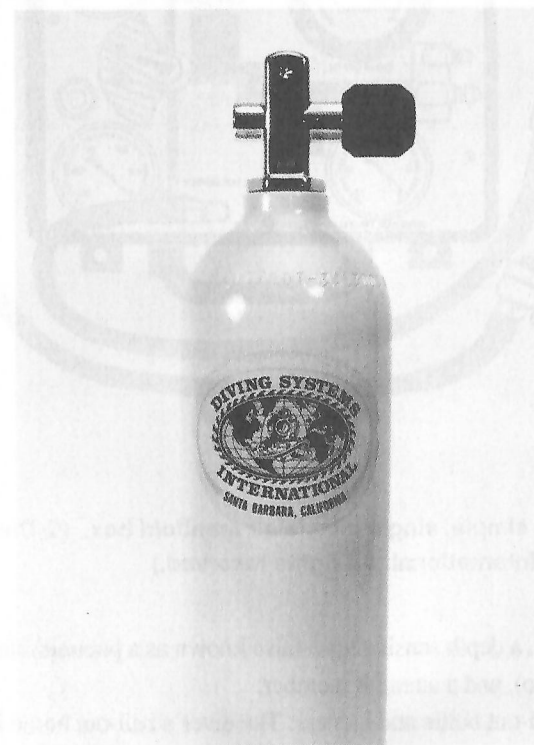


Fig. 2.5 The bail-out bottle is just one option for back-up air supply.

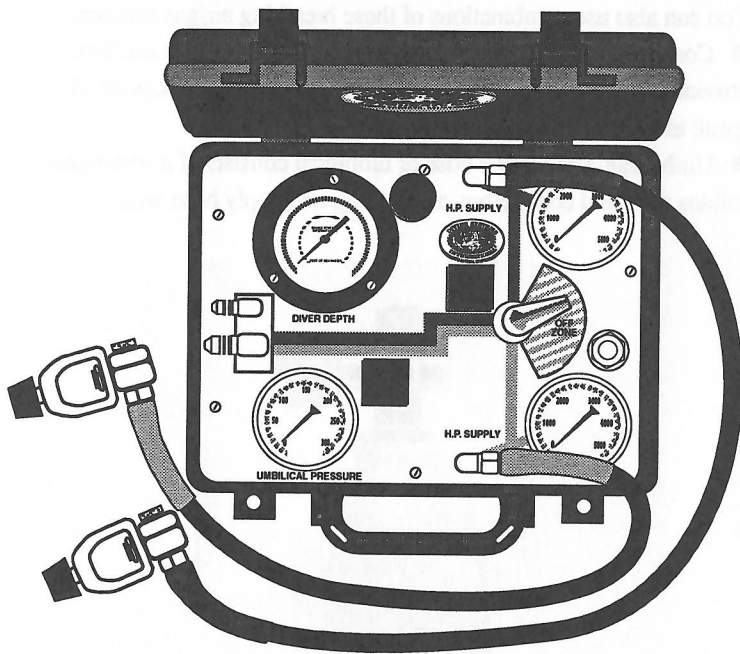


Fig. 2.6 A simple, single diver's air manifold box. (© Diving Systems International. All rights reserved.)

fittings, a depth sensing hose (also known as a pneumofathometer or pneumo), and a strength member.

- **Bail-out bottle and harness:** The diver's bail-out bottle is mounted on a rugged harness. The harness provides several functions. First, the umbilical connects to the harness before it



Fig. 2.7 A two diver communications box. (Courtesy Ocean Technology Systems)

connects to the mask. Secondly, the harness provides a place to hang the diver's tools. Finally, the harness may be equipped with a lifting ring that will support the weight of an unconscious diver for removing him from the water.

- **Bail-out block and regulator:** The bail-out bottle is connected to a first stage regulator and whip. The regulator is equipped with an over-pressure relief fitting to relieve the pressure in the whip in the event of a first stage leak, rather than blowing the hose. The whip is in turn connected to the bail-out block.

The bail-out bottle is normally left on and the block is turned off. In an emergency the diver turns on the valve at the block to gain access to the contents of the bail-out bottle. The diver's umbilical is also attached to the bail-out block as the primary gas supply.

- **Full face mask:** The EXO-26® is connected to the bail-out block by a single, low pressure whip.



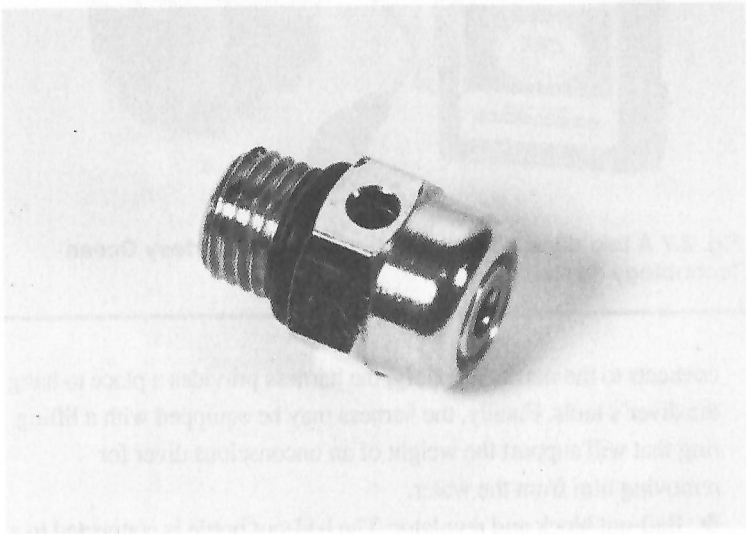


Fig. 2.8 An over-pressure relief valve for use on a first stage regulator. (© Diving Systems International. All rights reserved.)

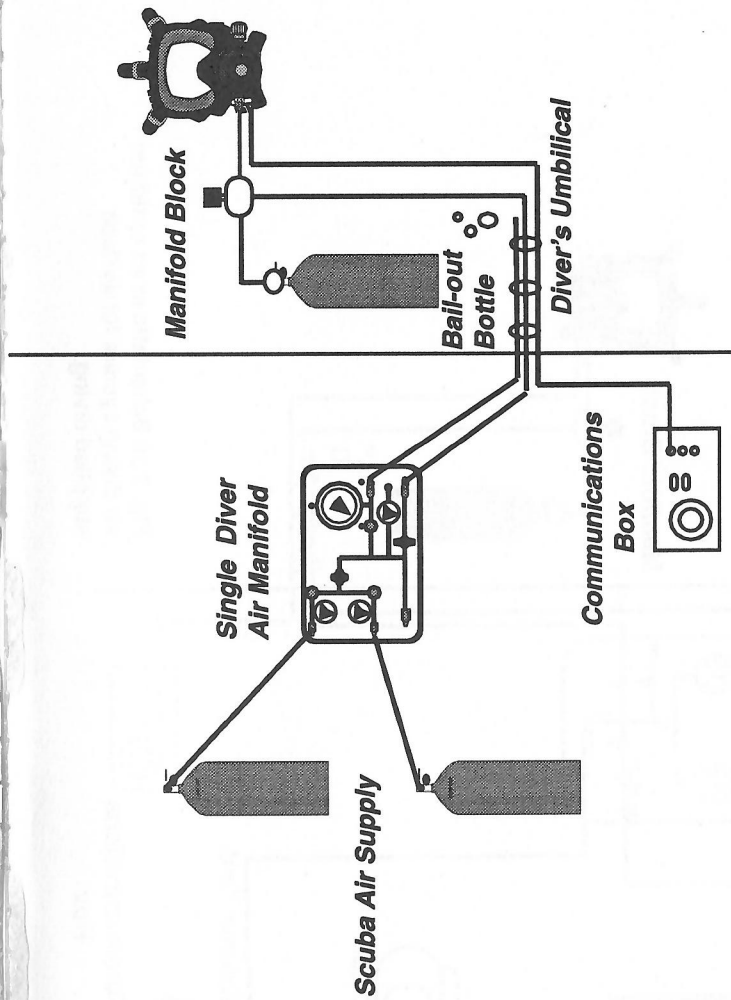


Fig. 2.9 Schematic of a simple air diving system for surface supplied diving.

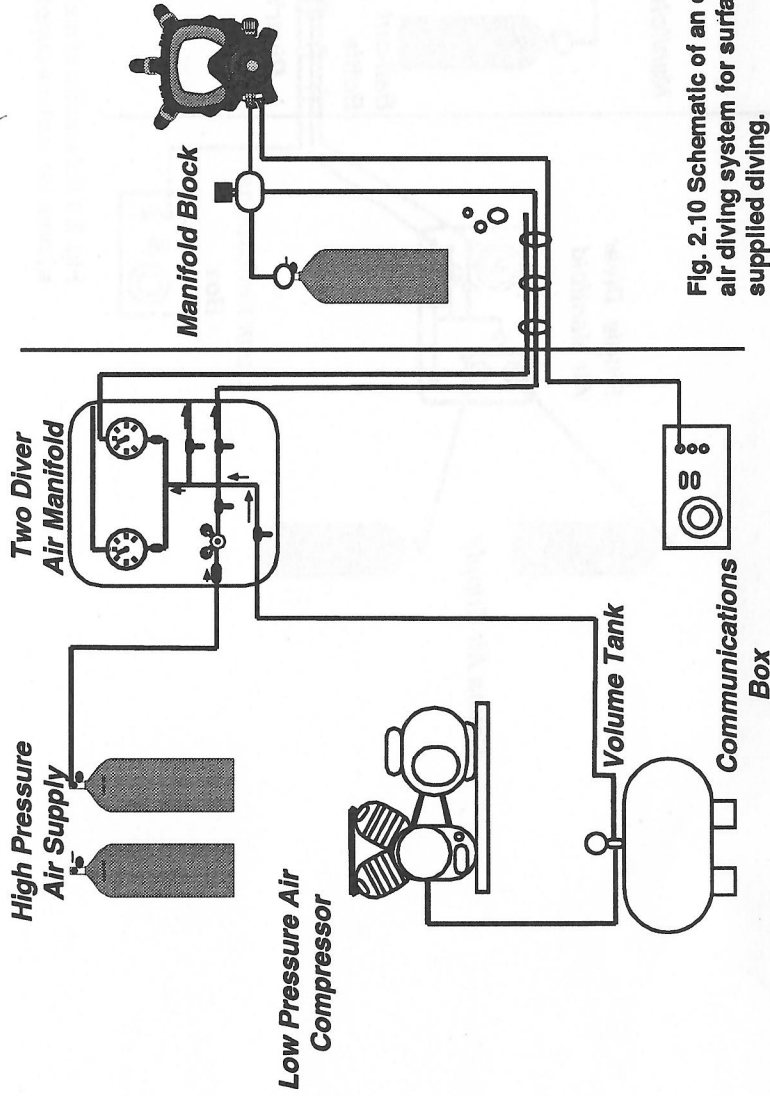


Fig. 2.10 Schematic of an optimum air diving system for surface supplied diving.

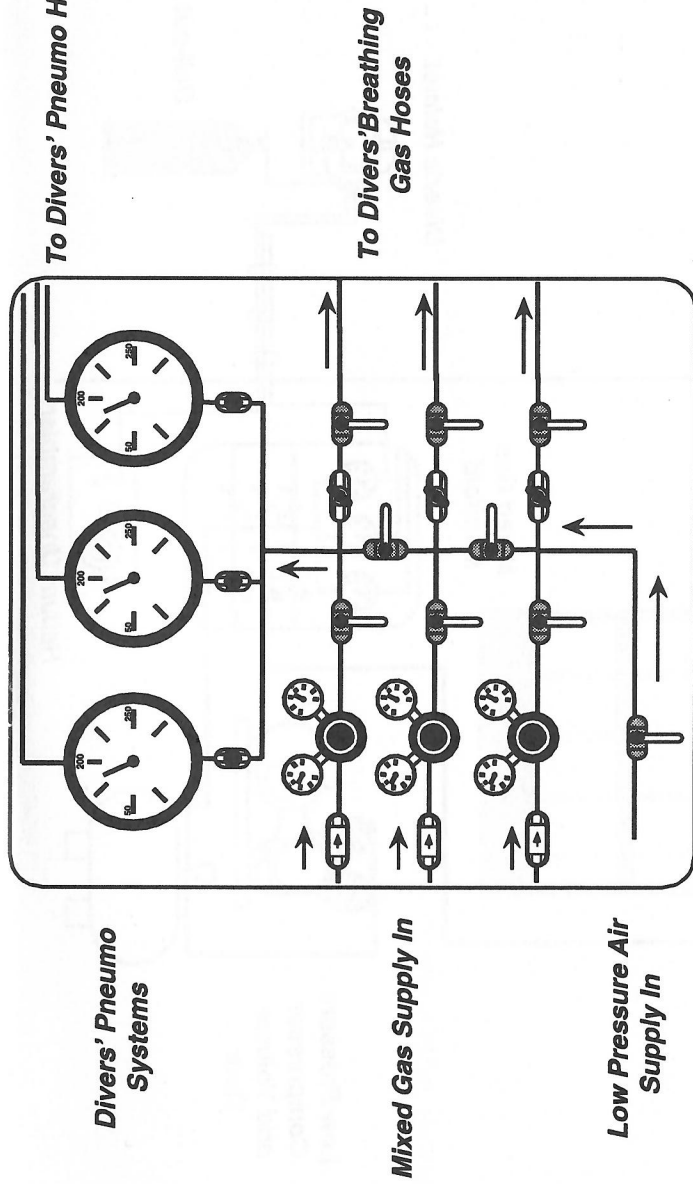
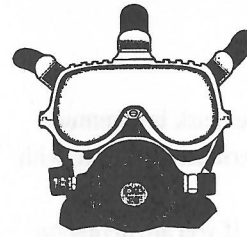
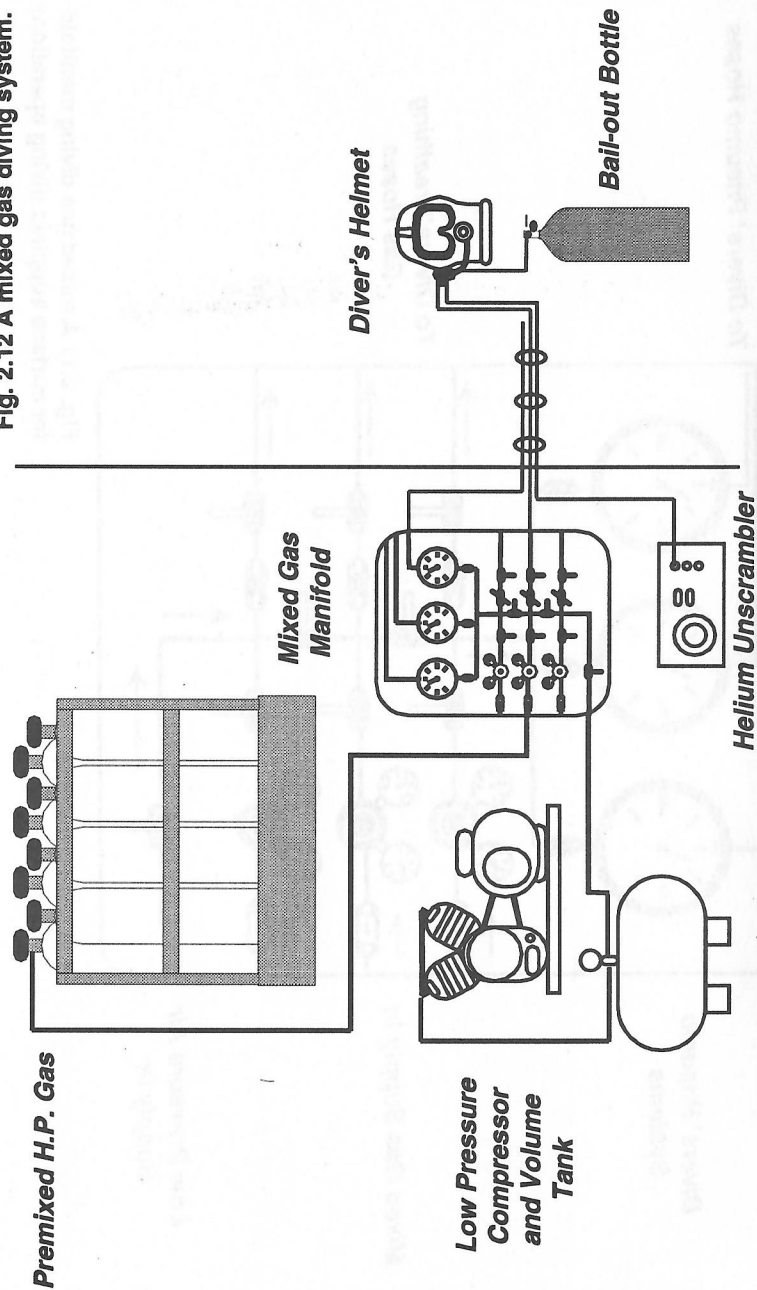


Fig. 2.11 A mixed gas diving manifold for surface supplied diving operations.

Fig. 2.12 A mixed gas diving system.



## Chapter 3

### Safety Considerations for Full Face Mask Diving

Like any piece of diving equipment, there are a whole set of separate safety considerations for diving with full face masks. A full face mask is no more dangerous than any other piece of diving equipment, be it a speargun, a dry suit, or a buoyancy compensator. However, when used improperly, without proper training, or without proper maintenance, a full face mask can be a contributing factor in a diving accident. There

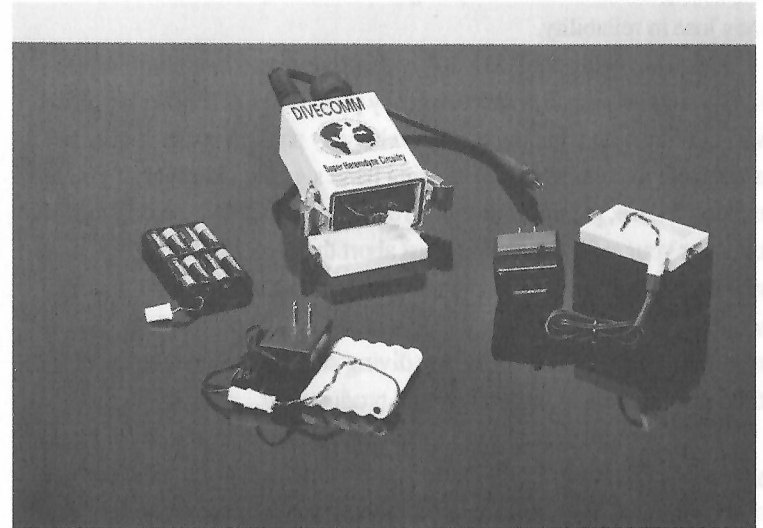


Fig. 3.1 Change or charge the batteries in your wireless system frequently. (Photo courtesy of Dive Comm, Inc.)

are always risks in diving. Sometimes a full face mask can help to reduce those risks.

## Loss of Communications

One of the major advantages to using a full face mask is communications. When communications are lost, this can seriously interfere with your diving safety.

Communications can be lost for many reasons. If you are diving on scuba and using wireless, many physical factors in the ocean can interfere with your communications. For example, if there is a wreck between you and your buddy, or between you and topside, it can totally block your communications. Similarly, if there is a reef between you and the person whom you are communicating with, this can also block communications. Other physical factors that can interrupt wireless communications include improper transducer location, thermoclines and large schools of fish.

Wireless communications can also quit due to battery failure, electronics failure, a flood of the unit, a torn cable, broken connectors, or other factors. Wireless communications can be excellent, but you must keep in mind that what you gain in mobility with wireless you may lose in reliability.

If you are using the EXO-26® with wireless and lose communications you must decide what emergency procedures to follow. If you are sport diving with a buddy in clear, relatively shallow water it may be acceptable to continue the dive using hand signals. However, if you are making a deep, technical dive where you are dependent on communications for your safety, then you must abort the dive. Similarly, if you are making a scientific dive where communications are essential to your work you will want to abort the dive until the communications can be repaired. This would apply to any diving situation where communications are essential to your safety and productivity.

When communications are lost in the scuba mode you should signal your diving partner so they know you are unable to communicate by speech. Immediately surface (after making a recommended safety stop) and return to the beach or your diving vessel.

In the surface supplied mode, communications are considered essential to safe diving. It is not acceptable to continue diving if you have no voice communications. If you lose communications while you are in the water you may use line signals until you return to the surface.

## Broken Face Port

Breaking your faceport is one of the most serious emergencies in full face mask diving. When you lose your face port it not only makes it impossible to see, it also makes it very difficult or impossible to breathe. Fortunately, this is an extremely rare occurrence. As of this writing, there has never been a known accident involving an EXO-26® faceport breaking underwater. The faceport is very rugged and made of tempered glass manufactured to very high standards.

If you are using the EXO-26® with scuba this is where carrying an extra (back-up) scuba face mask can make a big difference in your safety. This is also where an extra regulator or independent air source also can make a difference.

If your face port breaks while you are on scuba, and you have both a spare face mask and regulator, you will want to remove the EXO-26® as quickly as possible. Start breathing off your spare regulator and don your spare face mask. At this point the dive should be terminated and you should proceed immediately to your precautionary decompression stop with your dive buddy.

If your face port breaks while you are on scuba and you have not had the wisdom to carry a spare scuba mask or independent air source, then you must try to breathe from the mask as you return to the surface. It will be possible to get some air from the mask by leaning forward and ascending with your face parallel to the bottom. In this position, you can get air from the mask by either pushing the purge button to fill the interior of the mask with air, or by turning the regulator adjustment knob all the way out. The mask will trap some air in the frame and face seal. You must breathe very cautiously in this position to avoid inhaling water. If you allow the mask to continuously free flow you will run through your remaining air supply very quickly.

## Sharing Air While Using the EXO-26®

It is possible to share air with another scuba diver if both of you are wearing full face masks, but not by switching the mask back and forth. By adding a special whip or fittings to your system there is a relatively simple way to share air, but you must rig for this in advance.

To share air with another full face mask diver, both divers must be equipped with a bail-out block and a whip equipped with a quick disconnect or “sleeve lock” fitting. The hose that connects your mask to the bail-out block must also be equipped with quick disconnect fittings.

To share air with another diver, you must disconnect your mask from your bail-out block and connect your whip to the quick disconnect originating in their bail-out block. If your partner is equipped with a high flow first stage, both divers should be able to breathe at the same time without a problem.

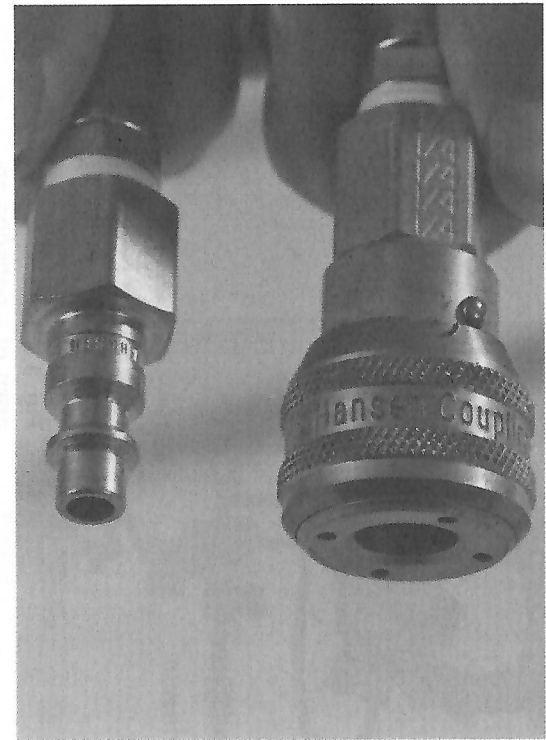
In surface supplied diving it is possible to use the depth sensing hose or “pneumo hose” from another diver’s umbilical to supply air. This technique is fully explained in the chapter on surface supplied diving.

Whatever method you use to share air must be fully tested under controlled conditions prior to diving in open water. You must be trained and proficient in the use of the mask under these conditions prior to any open water diving.

## Problems with In-Water Decompression on Oxygen

In-water decompression on oxygen (O<sub>2</sub>) is a relatively specialized diving procedure that was originally developed by the U.S. Navy. The purpose of in-water decompression on oxygen is to dramatically reduce the amount of time required for decompression purposes. By decreasing the in-water time, you help to eliminate the problem of keeping the diver warm during a long decompression and you decrease the amount of breathing gas required.

There are two ways that divers can do in-water decompression with oxygen while wearing a full face mask. The method that is probably most commonly used is to carry a separate, dedicated oxygen cylinder with a scuba regulator cleaned for oxygen service. At the first decompression stop with oxygen, the diver removes the full face mask, dons an ordinary scuba mask, and breathes from the oxygen regulator. The



**Fig. 3.2** Close-up view of quick disconnect fittings with a sleeve lock on the female fitting.

---

second method is to switch the breathing manifold over to an oxygen supply.

The negative side of in-water decompression on oxygen is that it can be extremely dangerous, for many reasons. In-water decompression on oxygen exposes the diver to the possibility of oxygen toxicity which may result in an oxygen convulsion. This is a serious situation to have happen underwater, even if you are wearing a full face mask. If you are wearing an ordinary scuba mask and breathing O<sub>2</sub> from a scuba regulator, an oxygen convulsion will most likely be fatal if there is no other diver nearby to help you.

For divers who switch to a scuba mask and dedicated oxygen scuba rig for decompression, the transition from the full face mask to the

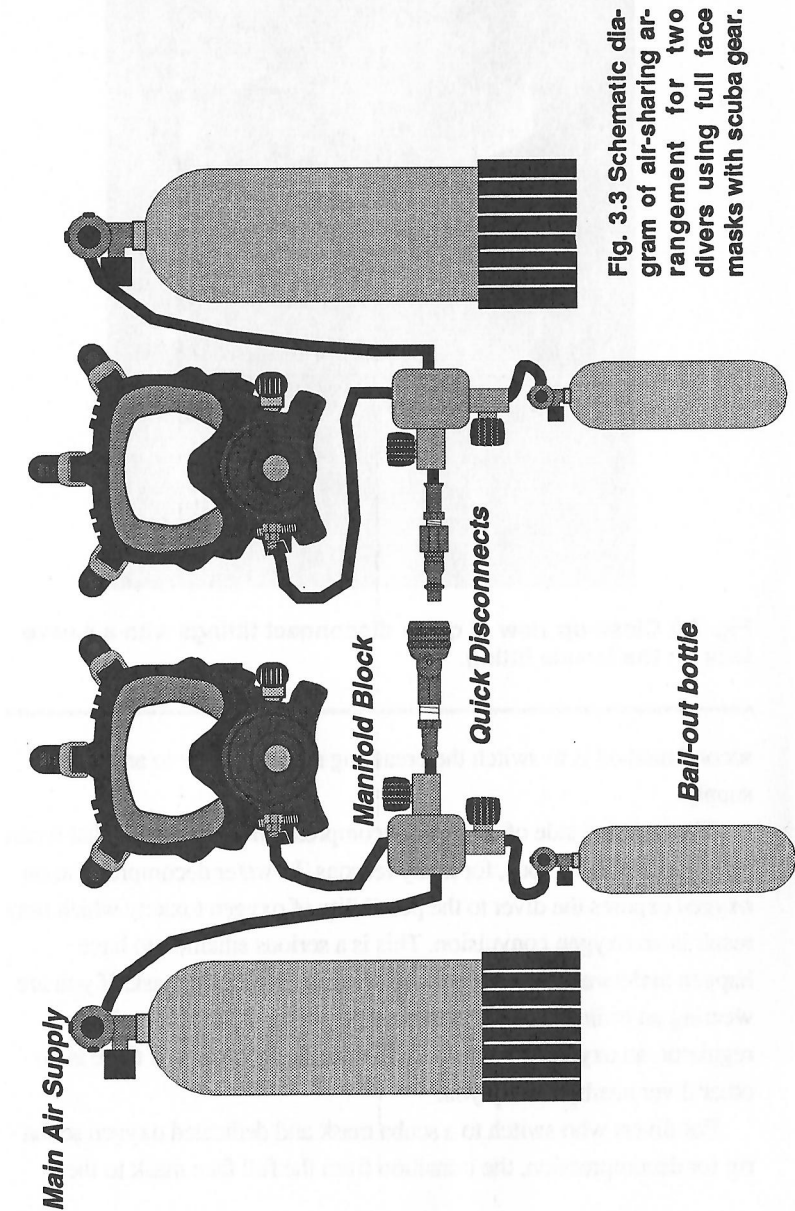


Fig. 3.3 Schematic diagram of air-sharing arrangement for two divers using full face masks with scuba gear.

scuba rig is hazardous. During the time interval from when you remove the full face mask until you don and clear the scuba mask you are “blind” underwater. In addition, you are without breathing gas until you get the oxygen regulator in your mouth. As a former commercial diver, I believe this represents an unacceptable risk level.

In-water decompression with oxygen supplied from the diver’s breathing manifold, using the EXO-26®, always presents the risk of an oxygen fire, even if certain precautions have been taken. The only way to reduce the chance of an oxygen fire to an acceptable level is to ensure that every component of the breathing system is oxygen clean, lubricated for O<sub>2</sub> service, and to only use breathing gases that have been supplied from a non-oil lubricated compressor. In addition, the standard components of the EXO-26® must be replaced with components that are oxygen safe. All O-rings in an oxygen system must be made from an oxygen compatible material and not neoprene. Some of the materials that have been used include Viton, Hypalon, and silicone.

Any time the breathing system is exposed to ordinary compressed air it must be considered to be “contaminated” and unsafe to use with oxygen again until every component has been cleaned and lubricated for oxygen service. Oxygen safe lubricants include products such as Krytox® and Halocarbon®.

### Risk of Entanglement

The risk of entanglement is always a threat in any diving situation. Any time you are trapped underwater without air, or forced to stay underwater beyond your planned bottom time, the situation is serious.

Given the types of diving where a full face mask is typically used, the risks of entanglement are usually higher. This is especially true in wreck diving, search and rescue diving, and in diving in polluted waters.

For the full face mask diver on scuba, the risk of entanglement is no greater than for a diver equipped with conventional scuba. If the diver is equipped with wireless communications, he will not be any “safer”, but he does have the advantage that he can call for help from his diving partner, or topside if the boat is equipped with a receiving unit.

When the full face mask is used in the tethered scuba mode there is an increased risk that the tether, rather than the diver, can become entangled. As mentioned before, in tethered scuba the diver normally has the option of disconnecting himself from the communications wire. If the wire can be freed it can be reconnected, provided it is designed to be reconnected underwater, or in a worst case scenario, it could be abandoned.

In the surface supplied mode, again the greater risk is that the tether (umbilical), rather than the diver, will become entangled. More often than not, umbilicals usually only snag on some obstruction rather than become hopelessly entangled. Most experienced surface supplied divers learn how to work with their umbilicals to avoid entanglement. In penetration dives the best method is to have the tender feed you slack, coil the umbilical in your hand, and pay it out as you wind your way through a wreck or other structure.



# Chapter 4

## The EXO-26® Full Face Mask

The EXO-26® Full Face Mask was developed by the design team at Diving Systems International in Santa Barbara, California. Bev Morgan and his team of divers and designers have the most extensive experience in designing helmets and full face masks for diving of any company in modern times. Their designs include the SuperLite-17®, the SuperLite-27®, and the Kirby Morgan Band Mask® (KMB-18 and 28).

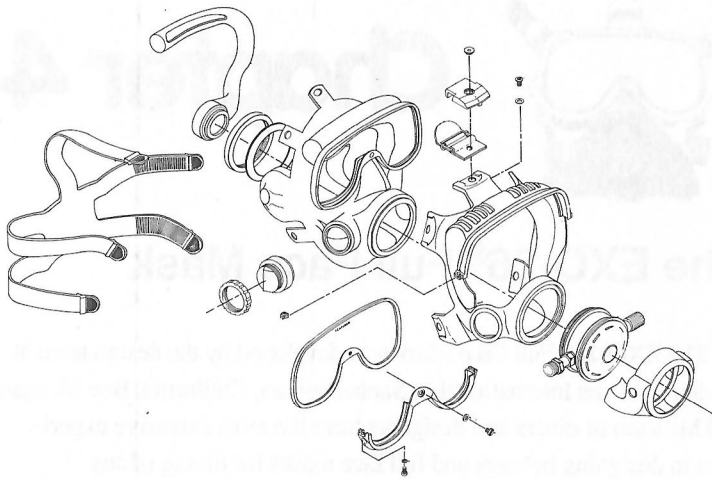
The EXO-26® was developed primarily as a lightweight mask for scuba diving, although it works quite well for surface supplied diving, too. The mask incorporates a number of unique features, although one of its strongest points is its simplicity. It is an easy mask to use and it has the least number of parts of any mask of this type. In addition, it requires only one special tool to perform maintenance on the mask.

The EXO-26® is composed of three major sub-systems. The basic mask is composed of the frame, face seal, and lens. The breathing system consists of the regulator and air inlet tube. The communications system is composed of the communications module. Each of these systems can be further broken down into their component parts.

### Breathing System

The breathing system on the EXO-26® has a number of special features that you should understand to take full advantage of the mask's performance. The breathing system has not been duplicated in any other diving mask.

Like most demand regulators, the EXO-26® provides air only when the diver inhales. Since the mask encloses both your nose and mouth

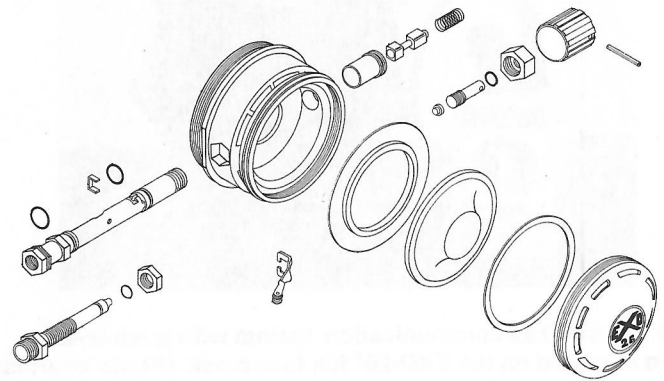


**Fig. 4.1 Exploded view of the EXO-26® Full Face Mask. (© 1990 Diving Systems International. All rights reserved.)**

you can breathe much more freely than you can when you are using an ordinary scuba regulator. Admittedly, most people find they tend to use more air when they are using a full face mask, particularly if they are using communications.

The regulator on the EXO-26® is a diver adjustable regulator that can be “tuned” when you are underwater. By screwing the knob on the left side of the regulator “out”, i.e., away from the regulator, it makes breathing easier. By screwing the knob on the regulator “in”, it makes breathing more difficult. This adjustment is of special value for deep technical diving or for surface supplied diving.

The breathing system on the EXO-26® uses a special air delivery tube. The tube mounts by snapping into a groove on the inside of the regulator and is supported by a channel on the inner left side of the mask seal. Instead of directing the air from the regulator straight into your mouth, the air flows into the tube and exits the tube through an opening positioned over the top of the face port. When the breathing gas flows down over the lens it helps to keep the lens defogged,



**Fig. 4.2 The breathing system used in the EXO-26® Full Face Mask. (© Diving Systems Intl. All rights reserved.)**

although some divers will find they need to use a bit of soap on the lens to keep it clear.

When you exhale into the EXO-26® your exhalation helps to warm the breathing mechanism to help prevent freezing. This also helps to warm each incoming breath. This makes the mask particularly good for ice diving.

The breathing characteristics on the mask are such that if the regulator is adjusted for maximum sensitivity and the face seal is “broken” (pulled away from your face) the mask will free flow. Since air is escaping from the mask under this condition, the regulator reacts as if you were inhaling. In most situations like this the mask will not flood, but you will lose a great deal of air.

During one of the test dives with an early prototype EXO-26®, marine biologist Kristine Barsky had this happen during an 80 foot dive when she did not adjust the mask tight enough. Although the mask became very loose on her face, and she could see the ocean below her chin, the mask did not flood at all.





**Fig. 4.3** A wireless communication system with push-to-talk button mounted on the EXO-26® full face mask. (Photo courtesy Dive Comm, Inc.)

## Communications

The communications system in the EXO-26® is one of the best systems in any full face mask or diving helmet. The modular design makes it exceptionally easy to change out components.

A typical hard wire communications system for surface supplied or tethered scuba diving consists of a topside communications box, a communications wire, and the system in the mask. The communications wire has a set of connectors topside. Underwater, the cable may terminate in bare wires, or one of several types of waterproof connectors. The most common types of connectors are either two pin or four pin Kintec connectors, also commonly referred to as “Marsh Marine” connectors. There are other types of connectors, including the Nelson Sea Lok and the “Amp” connector. The connector on the end of the umbilical is frequently a female connector while the connector on the mask is usually a male connector.

The connector at the mask penetrates through the module and is made waterproof through the use of an O-ring. The entire module seals against the mask seal and is held in place by a large plastic nut.

The system in the mask is composed of a microphone and two earphones. The microphone mounts directly on the module. The

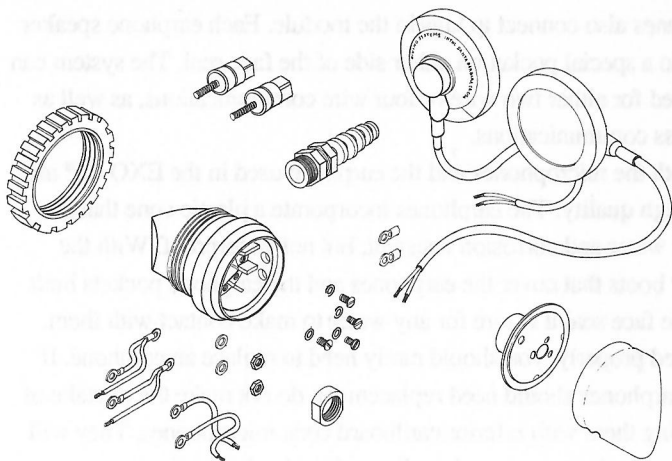
earphones also connect to lugs in the module. Each earphone speaker fits into a special pocket on either side of the face seal. The system can be wired for either two wire or four wire communications, as well as wireless communications.

Both the microphones and the earphone used in the EXO-26® are very high quality. The earphones incorporate a plastic cone that is highly water and corrosion resistant, but not waterproof. With the rubber boots that cover the earphones and the earphone pockets built into the face seal it is rare for any water to make contact with them. Handled properly, you should rarely need to replace an earphone. If your earphones should need replacement, do not make the mistake of replacing them with inferior cardboard cone microphones. They will not provide the same sound quality or length of service.

The microphone is also a high quality unit manufactured by Shure®, the same company that manufactures stereo cartridges and musical and broadcast quality microphones. The microphone is equipped with a special felt “sponge” that absorbs water to help protect the microphone. Periodically, the felt should be dipped in fresh water to dissolve the salt. The felt must be allowed to dry before reinstalling the microphone in the mask.

Salt water should be kept away from the earphones and microphone at all costs. When salt water contacts these parts it causes the magnets in them to rust and eventually ruins their performance. Salt water will also eat up the delicate wires that transmit the sound to the cones of the earphones.

Two wire communications systems are also known as “push-to-talk” systems. In a push-to-talk system, topside must push a button to communicate with the diver. When topside is speaking and the button is depressed it is not possible for the diver to speak to topside. Topside over-rides the diver in this situation. For this reason it is very important for topside to keep their communications brief. In a two wire system, if there is more than one diver connected to the communications box, they cannot talk to each other directly unless the system is connected with a “cross-talk” switch. On most systems, topside must activate the cross-talk switch for the divers to be able to talk to each other.



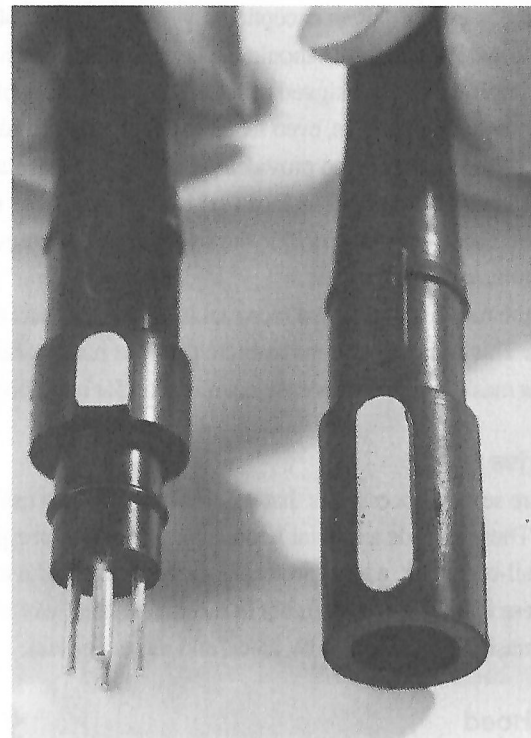
**Fig. 4.4 The DSI modular communications system used in the EXO-26® Full Face Mask.**

Four wire communications systems are “open” circuit systems. Using them is like using a telephone, everyone connected to the system can talk at the same time. Four wire systems are a bit more complex to set up and maintain than two wire systems.

Wireless communications can use the same types of connectors as hard wire systems. As in a hard wire system, the female connector is normally mounted on the wireless box and the male connector is mounted on the mask. Due to the more sensitive nature of wireless communications, bare wire connections should not be used. The best wireless systems are single sideband and a variety of manufacturers produce acceptable units.

Wireless systems can be used to talk diver to diver or diver to topside depending upon what equipment is available. The topside system consists of a small communications box and a transducer that hangs in the water.

Most wireless units operate like a four wire system in that both divers or the diver and topside can speak and be heard at the same time. However, some units are also equipped with a separate push-to-talk switch for the diver to use.



**Fig. 4.5 Male and female Kintec four pin waterproof connectors.**

If you are not using communications, a blanking plug must be inserted in the penetrator port. The blanking plug seals like the communications module, using the mask seal and the plastic nut to make the seal.

### **Mask Frame and Face Seal**

The mask frame of the EXO-26® is much like the exoskeleton of a lobster. It provides rigidity and strength that cannot be found in simple rubber full face masks like those made by Cressi Sub, and the older rubber mask marketed by U.S. Divers Co. All of the components of the mask connect to the frame including the face seal, the buckles for the “spider” or head strap, and the regulator.

The frame is made from an exceptionally strong plastic polycarbonate. With normal use the frame should never need replacement.

The rubber face seal is designed to seal on a wide variety of faces. It will seal easily on most divers, even those with very thin, small faces. The rubber of the face seal also provides the seal for the regulator and the communications module. The face seal is anchored to the mask in seven places. These locations include the five buckles, the regulator, and the communications module.

One of the nice features of the face seal is the nose pocket that is built into it. This pocket functions just like the nose pockets built into many scuba masks, and permits easy equalization for most divers.

### **Accessories**

There are several accessories that will make it easier to use your EXO-26®. These include a special hood, a face cushion, an equalizing device, a bail-out block, a head protector, carrying bag and a tool kit. None of these items are essential, but in most cases they will make the use of the mask more comfortable, safer, and more pleasant.

### **EXO-26® Hood**

The EXO-26® is designed to seal against a bare face, or against a latex hood such as those used with vulcanized rubber dry suits like those produced by DUI, Viking, Avon, and Gates. It will also seal against a neoprene hood provided there are no seams on the sealing edge.

If you are diving in cold water and want to keep your head warm using a neoprene hood, the hood must not interfere with the face seal of the mask. Diving Systems International, the manufacturer of the EXO-26®, produces a hood with a short neck and a face seal that can be conveniently trimmed so that the edge of the hood is just inside the face seal of the mask.

To check the fit of the hood, pull it over your head and make sure it is aligned properly on your head and chin. With the mask connected to an active air supply, don the mask and carefully tighten the spider. Check to see that the face seal and hood are in the correct position as you continue to tighten the spider. Use a white China marker and mark

the hood along the entire edge of the face seal. It is easiest if you have a friend do this for you. Be sure to push the earphones forward to mark the portion of the hood and face seal that are covered by them.

Remove the mask and the hood. Trim the face seal on the hood 3/8 to 1/2 inch forward of the line that you have drawn on the hood. This will provide an overlap of the face seal on the hood.

Once the hood has been trimmed, put it back on your head and put the mask back on your face. Have your buddy check to see that the mask overlaps the hood by about 3/8 to 1/2 inch. There must be no leakage of air into the mask caused by the face seal. If it does, try to adjust it first before you trim any more material away. Hoods that are not manufactured specifically for use with the EXO-26® may leak and create additional problems.

### **Equalizing Device**

For some divers, the nose pocket on the EXO-26® does not fit close enough to their nose to allow for easy equalization. Using the nose pocket can also be a problem for divers wearing thick mitts in cold water.

To assist divers who cannot use the nose pocket, DSI has designed an equalizing device that can be easily installed in the mask. The device attaches to the air delivery tube with Velcro® and can be removed if the mask is to be used by another diver. To use the device, you push the mask against your face until the nose block device is under your nostrils. Once you can feel it touching your nose, push up on the mask until the device blocks your nostrils and you can exhale to equalize.

### **Manifold Block**

When the EXO-26® is used for surface supplied diving it is essential to use a bail-out bottle as a back-up device in the event the topside air supply is lost. While most helmets and masks designed exclusively for full face mask diving incorporate a valve to control the bail-out supply, the EXO-26® does not. The reason there is no bail-out control included in the mask is that it was designed primarily for use with scuba and secondarily for use in the surface supplied mode.

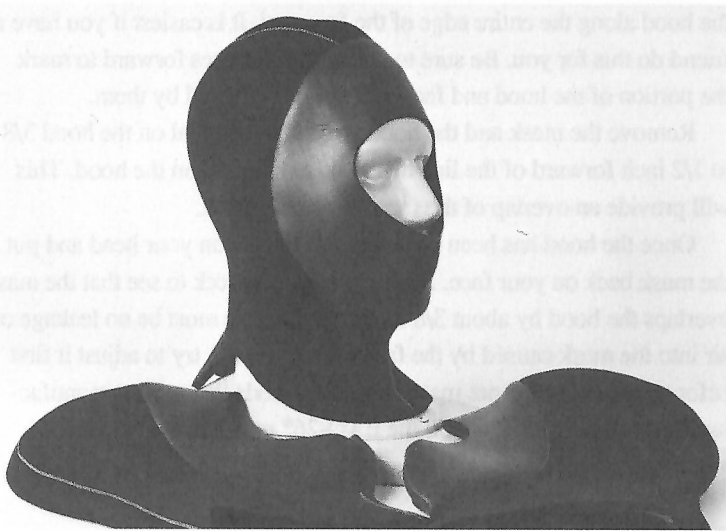


Fig. 4.6 Any hood used with the EXO-26® must not have a seam that interferes with the face seal. These hoods by Diving Systems International work perfectly with the mask.

The manifold block consists of a drilled block that is threaded to accept low pressure hoses and a simple on-off control valve. The block provides a means to control the flow of the bail-out bottle to the mask, and it also provides a method of connecting the mask to the umbilical. It also allows the connection of accessory devices to the topside breathing gas supply. You can connect a dry suit, buoyancy compensator, or other devices to the block.

The standard bail-out block is *not* designed for use with multiple gas mixtures as it might be used for deep technical scuba diving. It is designed to work with a single gas supply and bail-out bottle.

You will need a special adapter to connect the low pressure hose from your first stage to the non-return valve on the block. In deep surface supplied mixed gas diving the bail-out bottle is normally filled with the minimum oxygen concentration that will still support a diver on the surface. Typically this would be 16% oxygen in combination with some other inert gas, normally helium.

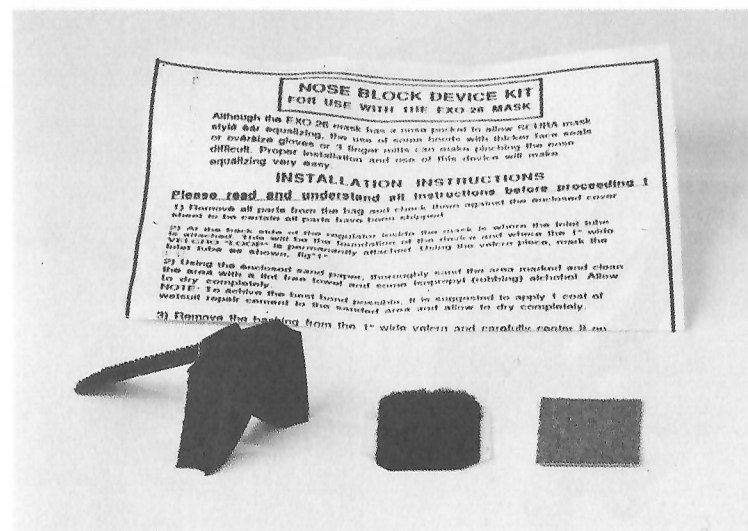


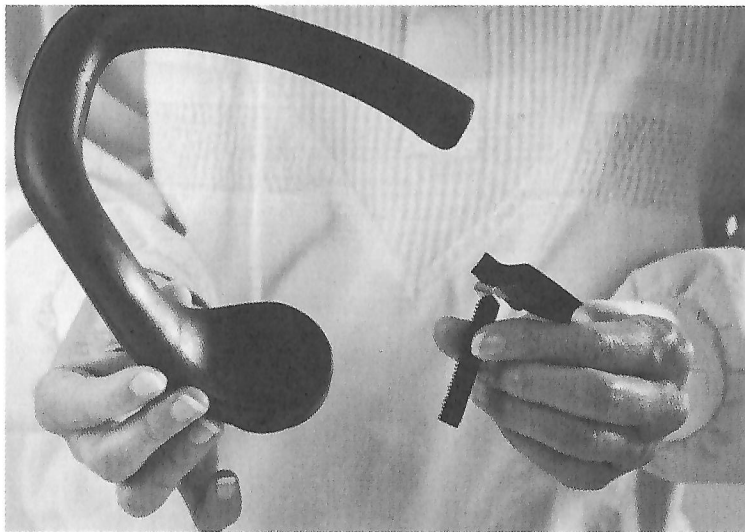
Fig. 4.7 The equalizing device may be required for some divers to be able to block off their nostrils to equalize the pressure in their ears.

## Head Protector

In certain diving situations it is extremely desirable to have some type of head protection. This is especially true when diving any place where there is potential for head injury. For example, for divers who must fight fires under wharves and piers, head protection is highly desirable. This is also true for penetration wreck diving or any other situation where your head can be injured by falling debris.

The optional head protector for the EXO-26® is made of hand laminated fiberglass with carbon fiber cloth and will give you good protection from minor impacts. However, it will not protect you from heavy objects. The head protector incorporates rapid removal and installation mechanisms, making it quick and easy to install and remove.

To install the head protector you will need to remove the spider from the mask. Squeeze the legs of the spider and feed them through the buckles to remove them. Remove the top center buckle cap and install



**Fig. 4.8** The equalizing device installs on the air delivery tube, which has been removed from the mask to allow you to see where the device is installed.

---

the hinge that mounts in its place on the top of the mask. You will need a 3/16 and a 1/8 inch hex key for this task. Make sure that the face seal is properly captured between the hinge and the mask frame by the screw and tighten until snug.

A template is provided with the head protector to allow you to punch the holes that attach the spider to the head protector. Position the template on the spider according to the directions provided with it and mark the location for the holes with a white China marker. Be sure to wear safety glasses while punching the holes. Attach the spider to the head protector with the screws provided. Make sure the concave portion of the spider is correctly positioned so that it will be pointing toward your head when the mask is on your face.

To attach the head protector to the mask, hold the mask in one hand and the head protector in your other hand. Turn the head protector so that the opening for your head is facing the floor. Slide the hinge pin in the top of the head protector into the hinge opening and turn the head



**Fig. 4.9** If you dive anywhere where your head can be injured, the head protector is recommended.

---

protector down. Once the head protector has been rotated down the hinge will hold it in place. Reconnect the spider to the mask by feeding the legs of the spider through the buckle.

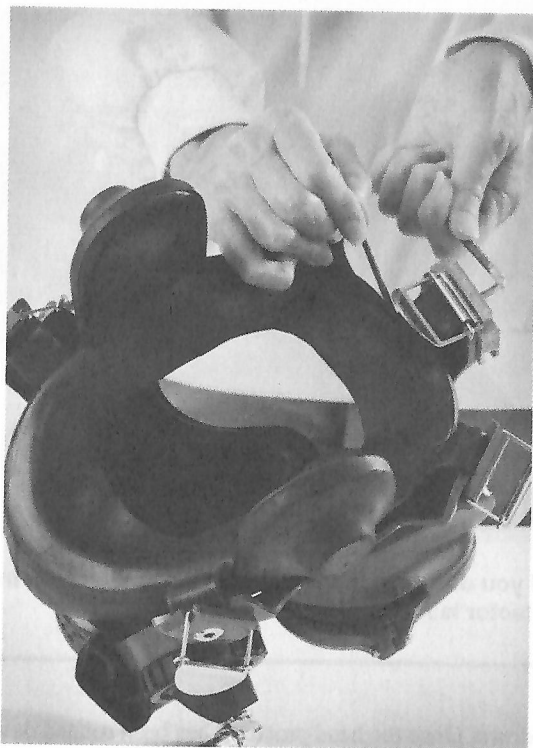
### Tool Kit

Because the EXO-26® is such a simple mask there is only one special tool needed to perform routine maintenance on the mask. This tool is a triangular shaped wrench that is used to tighten the ring that holds the regulator in the mask. Special tools are available for qualified technicians who perform repairs and tune-ups.

Every diver who uses the EXO-26® should carry this wrench with them on all dive trips. The tightness of the regulator should be checked prior to each diving day to ensure that the ring is secure.

### Mask Carrying Bag

Just as it is a good idea to pack your regulator in a separate bag inside your dive bag, it's a good idea to pack your EXO-26® in a



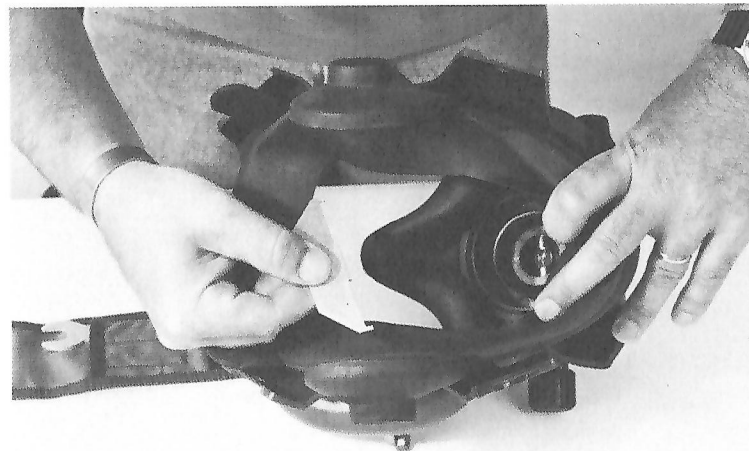
**Fig. 4.10 To install the head protector, you will need to remove the top buckle on the mask.**

---

separate bag for transport to and from the dive site. This will help to keep dirt and other foreign matter out of the mask. In addition, the bag will provide some mechanical protection for the mask.

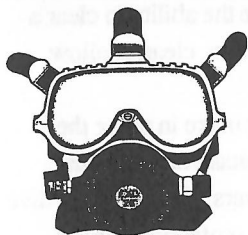
The mask bag provides a convenient way to keep all of your EXO-26® accessories and related equipment in one place. There is a pocket in the bottom of the bag that will hold your wireless communicator and tool kit.

Although the mask bag will help protect your mask, it is not designed for shipping your mask. If you are traveling by air or need to ship your mask somewhere for repairs, it should be packed in a heavy duty box or carried by hand.



**Fig. 4.11 The regulator mount ring should be checked for tightness using this special wrench prior to each diving day.**

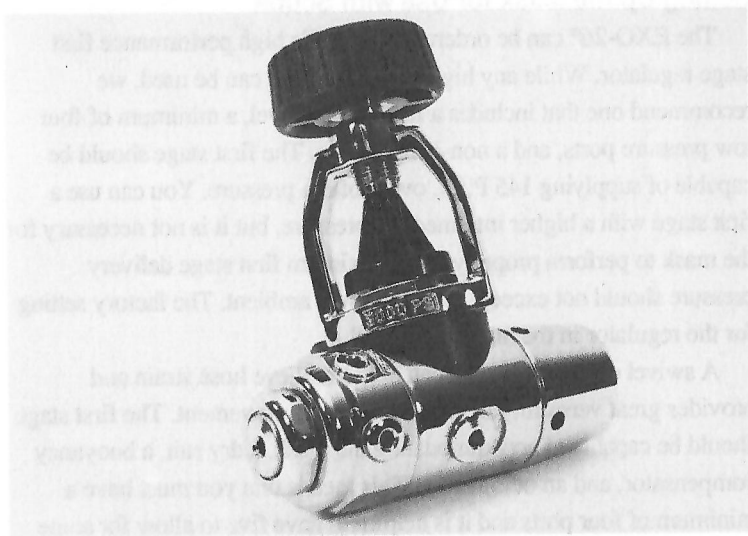
---



# Chapter 5

## Scuba Diving with the EXO-26® Full Face Mask

The EXO-26® is a very simple mask to use, but as with any new piece of diving equipment, proper training is essential. You should seek training from a certified diving instructor who is proficient in the use of the mask in open water.



**Fig. 5.1 Any first stage that you use with your EXO-26® must be capable of matching the demands of the second stage. This high flow first stage has been especially designed to work with the mask. (© Diving Systems International. All rights reserved.)**

In particular, you must be capable of donning and removing the mask by yourself. In addition, you must also have the ability to clear a flooded mask. These skills must be mastered in calm, clear, shallow water before any open water diving is attempted.

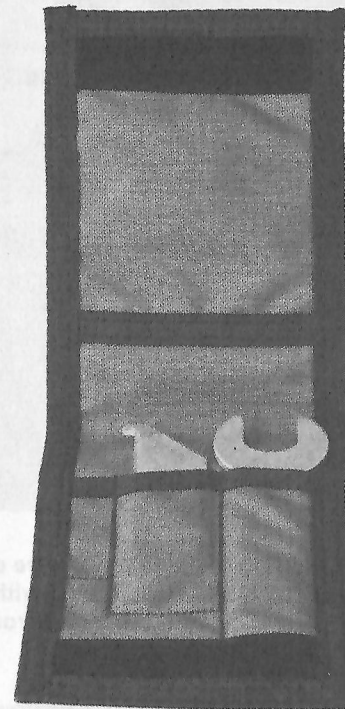
Probably the biggest mistake that most divers make in using the EXO-26® is in not requalifying in the use of the mask on an annual basis. This is particularly true for professional divers who may only dive when work demands it. It is not uncommon for a professional diver, such as a research diver or search and rescue diver, to learn to use the mask and then not use it again for many months. If the mask is not used on a regular basis it is easy to forget some of the specialized techniques required to use it efficiently.

To maintain your skills with this mask or any other piece of specialized diving equipment you should dive with it at least once a month. If you do not dive the gear that frequently you should complete a training course on an annual basis.

### Setting Up the Mask for Use with Scuba

The EXO-26® can be ordered with DSI's high performance first stage regulator. While any high flow first stage can be used, we recommend one that includes a first stage swivel, a minimum of four low pressure ports, and a non-icing design. The first stage should be capable of supplying 145 P.S.I. over bottom pressure. You can use a first stage with a higher intermediate pressure, but it is not necessary for the mask to perform properly. The maximum first stage delivery pressure should not exceed 165 P.S.I. over ambient. The factory setting for the regulator in the mask is 125 P.S.I.

A swivel on the first stage can help to relieve hose strain and provides great versatility in hose routing and movement. The first stage should be capable of accommodating the mask, a dry suit, a buoyancy compensator, and an octopus rig. This means that you must have a minimum of four ports and it is helpful to have five to allow for some flexibility in how and where you route your hoses. If you plan to engage in cold water diving a non-icing first stage is essential when you consider the high flow capability of the mask's breathing system. Diving Systems International's proprietary first stage works especially well with the mask.



**Fig. 5.2** It is helpful to have the thin open end wrench supplied with DSI's tool kit to help connect the low pressure hose to your mask.

To connect the mask to the first stage you will need two wrenches. It is helpful to have Diving Systems International's thin open end wrench that is supplied with the tool kit to make it easier to make the connection. The low pressure whip that connects the regulator to the first stage can be connected to any low pressure port on the first stage. Some first stage's now use an oversize hose with larger threads than those used in the past. This arrangement provides a larger inner diameter that permits a higher air flow.

A submersible pressure gauge is considered essential for scuba diving with any full face mask. Running out of air while wearing a full





**Fig. 5.3** An electronic pressure gauge and dive computer like ORCA's Phoenix is very useful when diving with a full face mask. This unit will tell you how much bottom time you have left based upon your present air consumption.

face mask is a serious emergency since in ordinary circumstances you must remove the mask if you want to share air with another diver. You can rig the system to a manifold block for use with an independent alternate air supply as mentioned previously, but this doesn't reduce the need for a submersible pressure gauge.

Many divers will find the use of an integrated dive computer and submersible pressure gauge, such as ORCA's Phoenix, helpful when diving with the EXO-26®. These units not only provide you with your current air pressure, but also give you your estimated remaining bottom time based upon your air consumption.

For deep diving with the EXO-26® an independent back-up air supply is considered mandatory. This supply should be rigged to the bail-out bottle with the manifold block. The bail-out bottle is usually mounted on the scuba tank with a bracket. Normally, the breathing gas supply will be on at the bottle and off at the manifold block.

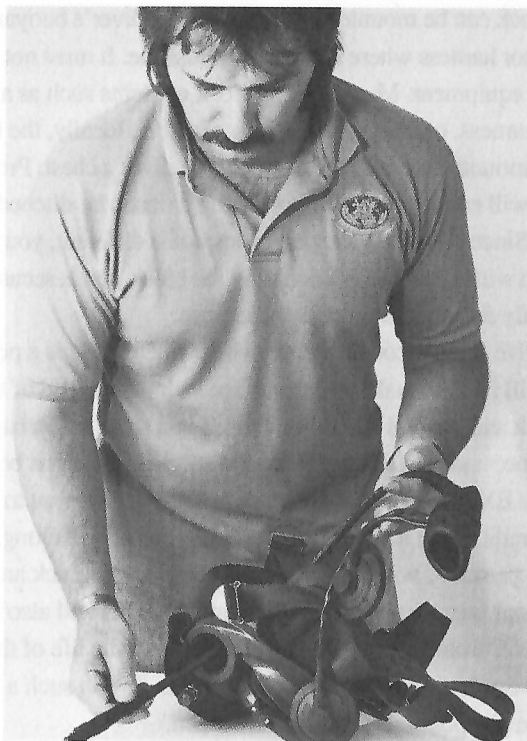
The block can be mounted anywhere on the diver's buoyancy compensator harness where it is easily accessible. It must not interfere with other equipment. Mounting the block on items such as a weight belt, tool harness, or other gear is not acceptable. Ideally, the block should be mounted close to the center of the diver's chest. Proper mounting will ensure that the entire scuba unit can be ditched together if needed. Since each buoyancy compensator is different, you will need to come up with a method of mounting the block that is secure, but that can be easily detached should the need arise.

If the dive is to be conducted anywhere where there is a possibility that you will need to make a long surface swim at the end of the dive, a scuba mask and snorkel should be carried in a small mesh bag. In the event it is necessary to use the mask and snorkel, you must be able to remove the EXO-26® by yourself. You will generally want to hold the EXO-26® rather than let it dangle freely as you snorkel along. If conditions permit it, you may prefer to swim on your back and hold the mask on your chest during surface swimming. This will also help prevent water from entering the mask, extending the life of the microphone and earphones. Always try to plan your dive in such a manner as to minimize the possibility of a surface swim.

### Setting Up for Wireless Communications

If your mask did not come set up for communications, you will need to install the communications module and speakers before you can use communications. You should order and purchase the communications module from the same dealer who sells you your wireless system to make sure that you end up with the right connectors on your system. The installation itself is very simple and takes only a few minutes. You can do this job yourself; it does not need to be done by the dealer.

To install the communications module, the first thing that you will need to do is to remove the blanking plug. Unscrew the mount ring (nut) on the outside of the mask and carefully push the blanking plug into the mask. Remove the blanking plug and store it in a safe place in case you need to use it later. Sometimes, after removing the blanking plug, the rubber seal will be displaced. Be sure the rubber is in its proper position before inserting the communications module.

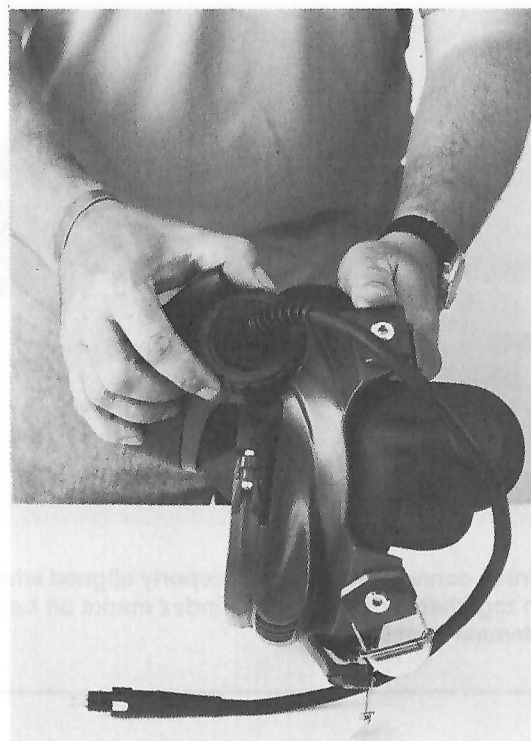


**Fig. 5.4** Installing the communications module in the mask is very simple.

---

Insert the communications module through the hole in the side of the mask. Make sure the module is all the way through the opening so that all of the threads on the module are on the outside of the mask. Align the microphone properly so the right earphone will easily reach the pocket on the right side of the face seal. The left earphone also must reach the left pocket without strain. The wires must tuck far enough back under the face seal so that they do not cause discomfort when the mask is tightened on your face.

Screw the nut onto the module and tighten it down snugly. There is no O-ring to seal the module. Instead, the module uses the compression of the face seal rubber by the nut to create a watertight seal. When the threads on the nut bottom out, you will have sufficient tension on the system.



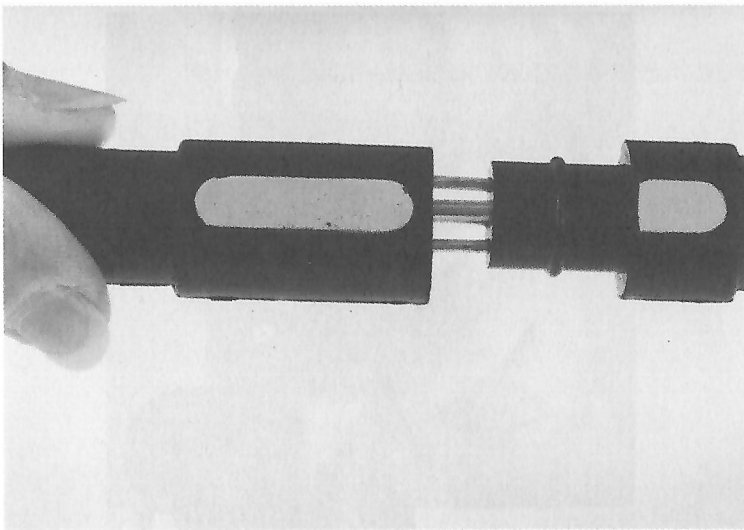
**Fig. 5.5** Be sure to tighten the nut until it is snug.

---

The right earphone has a shorter wire than the left earphone and will easily reach the right earphone pocket. The left earphone has a longer wire to enable it to reach the left earphone pocket. Feed the earphones into their respective pockets and tuck the wires out of the way underneath the face seal.

The wireless communications box should also be mounted on your buoyancy compensator. It must be mounted in such a fashion that it can be ditched with your scuba unit and the mask if needed. It must not be mounted on the weight belt, a tool harness, or any other equipment.

Several other factors must be taken into consideration when mounting the wireless unit. First, the wireless must be mounted in a position that places it close enough to the mask to make the connection

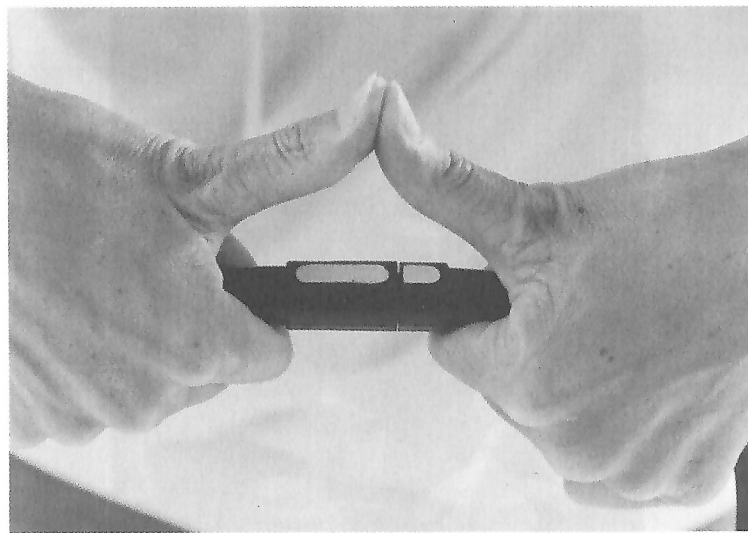


**Fig. 5.6** Kintec connectors must be properly aligned when you snap them together. Note the yellow index marks on both the male and female connectors.

between the mask and the wireless box without placing a strain on the wire. Secondly, the unit must not be mounted in a position that blocks the signal from the transponder that actually sends the signal. For this reason, the wireless box should not be mounted underneath a buoyancy compensator or other equipment.

The wires that connect the mask to the wireless unit should be routed in such a manner that they do not hang limply away from the diver. Any excess wire should be tucked back under other equipment or taped with electrical tape. This will help to prevent the possibility of entanglement when the diver is working on a wreck or around other obstructions.

You may want your diving partner or another diver to help tuck or tape the wires back out of the way after you have donned the mask. This will generally lead to a much “cleaner” set-up than if you do this prior to donning. If this procedure is followed the person who assists you with this must be experienced in diving with the mask so they understand



**Fig. 5.7** Disconnect Kintec connectors by holding the connectors firmly and pushing your thumbs apart as shown here. Never pull on the wires at the base of the connectors.

any problems that can be created by incorrect mounting. In addition, you should instruct them in exactly where and how you want the wires routed or taped so that you can find them by feel if needed underwater. If this is done incorrectly, it can create a situation where you could be trapped in your equipment. This could be fatal in an out of air emergency.

Different types of waterproof connectors require different methods to mate them together. Kintec waterproof connectors simply snap together, but you must make sure that the large pin on the male connector is properly aligned with the large hole in the female connector.

There is normally an index mark on the female connector to indicate where the large hole is located. On most connectors this may be indicated by a yellow mark, on others there just may be a raised bump. The connectors should “pop” when they are connected right. Kintec connectors must not be twisted at all or the pins may break.



**Fig. 5.8 Making the connection on an Amp connector.**

To disconnect a Kintec connector, grasp the two connectors firmly in your hands (one in each hand). Put your thumb tips together and then firmly push them apart until the connectors separate. Do not twist the connectors at all or this may cause damage.

Another popular connector is the Amp connector. This is also a multi-pin connector. The Amp connector is made from a hard plastic and screws together with a large threaded “nut.”

An O-ring is required for the Amp connector to work properly. The O-ring is normally located inside the female half of the Amp connector. Without the O-ring, the communications connector will short out and the communicator will not work. Always check to make sure the O-ring is present before you screw the connectors together. Screw the two



**Fig. 5.9 Always check the spider carefully prior to dressing in.**

connectors together until the nut bottoms out. Do not apply force to the connectors.

Whether you are using an Amp connector or a Kintec connector, the two connectors should be taped together with a bit of waterproof electrical tape, just to be sure that the two connectors do not come apart underwater. Stretch the tape to ensure that it sticks properly.

You can test the wireless communications before you dive. Fill a bucket with water and place both diver’s communicators in the bucket. Both you and your partner should don your mask and try speaking to each other, but you don’t need to put your heads in the bucket. If you will be communicating with personnel topside, submerge the surface transponder in the bucket too to test communications between topside and the diver.

## Mask Preparation

Several steps should be taken to prepare the mask for diving. The most important points are the inspection of the mask itself.

Check the spider over carefully for any cracking or checking. It must be in good condition. If it is not, it must be replaced.

Examine the face seal rubber for any cracking or tears. If the face seal is torn this will cause the mask to leak and the regulator to free flow, causing your air supply to be rapidly depleted.

Make sure that the regulator adjustment knob is functioning properly. It should turn easily with no rough spots. When the air is turned on, the regulator should begin to free flow when the knob is backed out, away from the regulator. When the knob is turned back in the free flow should stop and it should make breathing through the regulator more difficult. Even with the knob turned all the way in you will still be able to breathe if the regulator is functioning properly, although breathing will be difficult.



**Fig. 5.10** Make sure the regulator adjustment knob is functioning properly prior to diving.



**Fig. 5.11** You may want to apply a bit of soap to the lens to help keep the mask from fogging up.

Check the regulator mount nut to be sure that it is snug by using the special triangular shaped wrench included in the DSI Tool Kit. To check the nut, you will need to remove the breathing tube in the mask where it connects to the flange on the regulator. It is not necessary to remove the entire tube.

Push the round end of the breathing tube out of the way. Note the two holes in the regulator mount ring. They are located 180 degrees apart. The two points on the regulator tightening wrench fit into these two holes. Slip the wrench into these holes and apply firm pressure to the wrench. If the nut is not tight, the regulator can leak or actually fall out of the mask, although this is highly unlikely. Tighten the nut until it is snug.

The round end of the tube must snap onto the flange into a groove on the regulator inside the mask. Push this down back onto the flange at an angle to get it started. If any portion of the air delivery tube has escaped from the groove on the left side of the face seal rubber it must be pushed back into place.

Be sure to also check the regulator cover to ensure that it is screwed down tight. There is no clamp to hold the regulator cover in place; it is only a friction and compression fit.

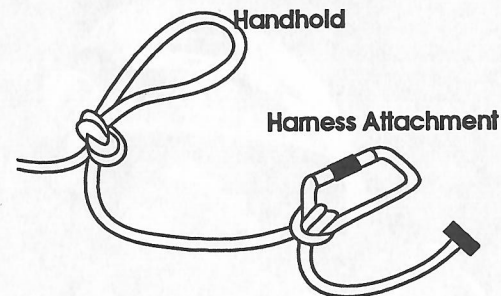
There is an optional foam insert that fits underneath the upper half of the face seal. This insert serves to make the mask more comfortable. However, the insert does not allow you to get your face as far inside the mask and you may want to try diving without it. Whether you use the insert or not is a matter of personal preference.

Just prior to the time that you enter the water, the inside lens of the mask should be lightly coated with a thin film of soap or defogging solution. Use a dish washing liquid such as Joy® soap for this. This is essential to prevent the lens from fogging up since the air that flows across the lens from the air delivery tube may not keep the lens clear by itself. If you apply the soap too soon it will dry on the lens and not be effective. It needs to still be moist when you enter the water.

### Setting Up the Mask for Tethered Scuba Diving

Setting up the mask for tethered scuba diving is almost identical to setting up for regular scuba diving, with a few important exceptions. The main difference is that the diver needs to wear a harness for the attachment of the “tether” or communications wire.

At the diver’s end, the communication rope is normally tied with two loops. The rope would run from the connector on the mask to the first loop which is attached to a chest harness worn by the diver. This attachment is made by either a carabiner or snap hook. The comm rope then travels approximately three feet to the larger loop which the diver will use as a hand hold. The harness must be donned prior to the donning of your buoyancy compensator. The purpose of the harness and attachment arrangement is to avoid topside exerting a direct pull on the mask that could pull the mask off your head.



**Fig. 5.12 This is one possible comm rope hookup for tethered scuba diving.**

In tethered scuba diving it is recommended that you do *not* tape waterproof connectors together. In the event the communications wire becomes snagged underwater you may need to be able to disconnect it. Mate the connectors together according to the manufacturer’s instructions. Be sure to test the communications system between the diver’s mask and the topside unit before the diver enters the water.

In some ways, tethered scuba operations are much like surface supplied diving operations in that the diver is somewhat dependent on the support of topside. Since tethered scuba is most commonly used in search and rescue operations, the diver is part of a team and must respond as such. The tethered scuba diver works under the direction of a topside team leader and must respond to his instructions.

### Donning and Adjusting the Mask

One of the cardinal rules of full face mask diving is that you must have the ability to don, adjust, and remove the mask by yourself. This is fundamental to your safety. If you cannot perform these basic skills you must not dive with this mask. Without the ability to remove the mask by yourself, you could suffocate in the event that you ran out of air.

Connect the first stage regulator to your tank. Screw the regulator adjustment knob all the way “in” so that the knob is close to the regulator body. Do not force the knob or put any pressure on it. Just turn it gently until it stops turning. If this is not done, the regulator may free



**Fig. 5.13** You must be capable of donning and removing the mask by yourself.

flow when it is first turned on and you will lose a lot of air from your tank. When the air is first turned on there should be no air escaping from the regulator if the knob is turned all the way in.

Prior to donning the mask you should have all of your other equipment on. If you are using wireless communications it should be attached to your BC just prior to donning the mask. You must also don your hood if you will be wearing one.

To don the mask, loosen the spider so that it is at its maximum opening. Lift the mask over your head and hold it snug up against your face without tightening the spider. Test breathe the mask in the demand mode and adjust the regulator knob “out” until the regulator just begins to free flow and then back “in” one half turn. Check the purge button on the mask to be sure that it is operating correctly.

If everything on the mask checks out, go ahead and tighten the spider. Start by tightening the bottom legs of the spider first. Tighten the straps alternately to pull up tension evenly to avoid having the mask tighter on one side or the other.

It is essential to make sure the mask is snug on your face. It does not need to be tight, but it does need to be snug. If the mask is too tight it will become extremely uncomfortable after a very short time. If the mask is too loose, it will create an excess air space inside the mask, causing extra buoyancy and visual distortion. In addition, if the mask is too loose it can make it difficult to equalize. The cup of the spider should be positioned so that it is on the center of the back of your head, low, but not on your neck.

For most divers, the mask is properly adjusted when your nose is partially into the nose pocket. An additional clue to proper adjustment is whether your lips are close to the breathing tube. You will need to experiment in shallow water to find the best adjustment for you.

### Entering the Water

Entering the water while wearing a full face mask is not much different from entering the water while wearing ordinary scuba. You can use any entry that you would use with scuba as long as you follow a few simple precautions.

If you are doing a giant stride entry from a height, be sure to cover the bottom seven holes on the regulator exhaust tee. This will help to prevent any turbulent water from flowing past the exhaust valve and entering the mask. Hold the mask tight against your face while the heel of your hand cover the holes.

If you are diving from a small boat, such as an inflatable, and will use a backwards roll, turn your head to either side to prevent water from forcing its way past the face seal and into the mask. If water does enter the mask it can be cleared easily by keeping your head low and pushing the purge button.

After you are in the water you may also need to readjust the spider or mask as buoyancy may change the mask’s position.

### Equalizing

As in all diving, your equalization should start on the surface. Be sure to equalize early and often. Most divers will be able to grasp their nose through the nose pocket on the mask, although some will need the accessory equalizing device. You should check this out before you dive

with the mask for the first time to see if you will be able to equalize without the device. Don't forget that thick gloves or mittens may also necessitate the use of the accessory device.

### Surface Swimming

Surface swims while wearing your EXO-26® should be as short as possible since every minute that you spend on the surface you are using up your air supply. For this reason, if you have a long distance to swim, you will either want to swim on your back, holding the mask on your chest, or use a scuba mask and snorkel for this purpose. Swimming on your back is preferred.

If you do remove your mask while you are in the water it's a good idea to try to keep it out of the water as much as possible. This will help to prolong the life of the microphone and earphones. In addition, due to the shape of the mask it can be difficult to get all the water out of the mask once it has gotten wet. Any water left in the mask after it is flooded will not interfere in any way with your breathing, but it can be an annoyance. It is better not to remove the mask in the water if at all possible.

### Underwater with the EXO-26®

You will find that diving with the EXO-26® Full Face Mask is extremely easy and comfortable. The regulator breathes well and the adjustment knob allows you to fine tune the regulator to your exact needs. As you dive deeper you will want to screw the adjustment knob out, away from the regulator body, to make breathing easier.

The regulator breathes the hardest when you are working in the face up position, such as if you are working face up underwater on the hull of a ship. Conversely, the regulator has a tendency to free flow if you are working in a face down position. Use the adjustment knob to compensate for these differences in regulator sensitivity. In addition, at very shallow depths the regulator may "flutter," but this will disappear as you dive deeper. Fluttering isn't bad; it's just the sign of an extremely well adjusted high performance regulator.

You can adjust the spider during the course of your dive. Adjustment is very rapid and is easily accomplished by pushing the mask

against your face and loosening or tightening the straps. You will want to experiment with the adjustments to discover what combination of tension on the top and bottom straps work best for you.

Be sure to check your submersible pressure gauge frequently during the dive. This is especially important if you are diving deep, in an overhead environment such as a wreck, or in polluted water. Running out of air is always a serious emergency, but running out of air while wearing a full face mask is even more serious. This type of emergency underlines the importance of having an alternate air source and manifold block.

If you are diving the mask with tethered scuba it is essential to keep track of your tether at all times. Try to dive with the minimum amount of slack possible. This is easy to do because you will be in constant



**Fig. 5.14** Most divers find it very easy to equalize the pressure in their ears by using the nose pocket on the mask.



communication with topside. You will need to direct the line tender topside when it is time to take up slack and when it is time to feed you more. With a little practice, it is easy to become a smooth functioning team.

In the tethered scuba mode, any time you encounter an obstruction underwater be sure to go over it, *not* under it. It is imperative that you always leave yourself a clear path to the surface with no obstructions that can block your way. Of course, if your line becomes hopelessly entangled you can always disconnect it, although you may end up losing the line if you cannot get it disengaged. Obviously, if you do disconnect the line you will lose communications while you are disconnected.

### Emergency Procedures

While all of the principles of conventional scuba apply to full face mask diving, there are some special procedures that you will need to follow in emergencies. None of these situations are especially dangerous with the exception of an out of air emergency. Even an out of air emergency can be dealt with rather routinely if you are properly equipped.

Losing communications is a definite hindrance whether you are using wireless or tethered scuba. In the case of wireless you will need to make a judgment call in regards to the severity of the situation and the risks involved. For example, if you lose wireless communications while diving on a shallow reef in warm water with 100 foot visibility it probably isn't necessary to abort the dive, depending upon how important communications are to the success of your project. On the other hand, if you are diving deep in low visibility and communications are critical to your safety and the successful completion of your dive, it would be best to abort the dive until the communications are restored.

When communications are lost while using tethered scuba it may be possible to complete the dive safely using line pull signals, depending on the nature of the dive. Again, this is a judgment call on the part of the diver and the rest of the dive team. Ultimate authority rests with the team leader in tethered scuba operations and he may decide to "pull" the diver from the water if he decides that the operation is too hazardous without communications. As in any diving operation, the diver



**Fig. 5.15 Use the adjustment knob to adjust the sensitivity of the regulator.**

---

always has the option to abort the dive at any time and must never be ridiculed if this is his decision.

If the regulator on your mask goes into the free flow mode while you are on scuba you need to sort out the problem quickly, particularly if you are deep. With the high flow breathing characteristics of the EXO-26® you can lose a large quantity of air in a very short time during a free flow. In addition, aside from the loss of air, communications will be virtually impossible during any free flow episode.

The first thing to check when the mask starts to free flow is the regulator adjustment knob. If you adjusted the regulator knob as you descended and forgot to screw the knob back in as you came up this may be all that is required to correct the problem.



**Fig. 5.16** You can adjust the spider underwater.

---

Diving in conditions of heavy silt, mud, or turbulent sand can also make your regulator free flow by jamming the purge button. Check to see if this is the problem by pushing the free flow button several times to see if you can loosen anything that is causing it to stick. If you cannot correct the problem after one or two attempts then this is probably not the cause of the problem.

When a free flow cannot be corrected immediately you must surface and return to your topside support station. Do not continue to dive under any circumstances since you run the risk of running out of air.

It is very rare for an EXO-26® Full Face Mask to flood, but clearing the mask is very simple if this happens. Push the purge button and most of the water will be rapidly forced out of the mask. Usually there will be



**Fig. 5.17** Check your submersible pressure gauge frequently while diving.

---

some water remaining in the air delivery tube that will also need to be cleared after pushing the purge button. To clear this remaining water, roll your head to the left, then forward and upright. Any water in the tube should exit at the top of the mask and flow down across the lens, although sometimes you may need to repeat this action more than once. Water in the tube is more of a nuisance than anything else and will not seriously affect the breathing characteristics of the mask. Usually the drain hole at the bottom of the tube takes care of the rest of the water.

Running out of air while wearing a full face mask is a serious emergency if you do not have a back-up air supply. If you are equipped with a manifold block then it is a simple matter of opening the valve on the block (turning it counter-clockwise) and breathing from the back-up



**Fig. 5.18** To clear the mask of water, push the purge button on the front of the regulator.

supply. As soon as you go on your back-up supply the dive must be discontinued. Keep in mind that if your dive involves decompression then you must carry sufficient breathing gas with you to see you through your decompression.

If you are using nitrox for decompression purposes your manifold block should be rigged so that you can access this gas through the use of a quick disconnect fitting. Removing your mask to switch to conventional scuba for pure oxygen for decompression purposes is not recommended since you are blind and have nothing to breathe once the full face mask is off your face. If you need to use a full face mask and your dive is deep enough to warrant decompression on oxygen then surface supplied diving with surface decompression on oxygen is the recom-



**Fig. 5.19** Use a mask bag for transporting your mask to and from the dive.

mended procedure. This is beyond the scope of recreational diving and most search and rescue operations.

It is possible, as mentioned previously, for two divers wearing full face masks to share air through the use of manifold blocks and quick disconnect whips. The whips must be long enough to permit free movement for both divers, particularly if you must exit a wreck with tight passageways or other obstruction. Once air sharing is initiated the dive must be terminated.

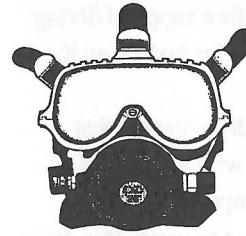
### Post Dive

After you surface from your dive and return to the boat you will probably want to switch tanks for another dive. After you have removed

your equipment, purge the regulator system by using the purge button. You can also screw the regulator adjustment knob out until the mask free flows. Remember to screw it back in before you connect the mask to a tank for your next dive.

If your mask got wet inside and you are going back into the water right away, dry the inside of the mask with a towel so you will be ready for the next dive. Otherwise follow the rinsing procedures found in *Chapter 7*.

Be sure to store your mask in its carrying bag for the trip home. Screw the regulator adjustment knob all the way in, then out a few turns, prior to transport so the adjustment shaft isn't damaged if the mask bangs into anything. After cleaning and drying, the knob must be backed out all the way for storage.



## Chapter 6

### Surface Supplied Diving with the EXO-26® Full Face Mask

Surface supplied diving with the EXO-26® provides a higher level of safety and redundancy than diving with scuba. In many operations it is much safer than diving with scuba.

Many divers think that surface supplied diving is more dangerous than scuba diving. Although there is more equipment than used in



**Fig. 6.1** Learning to use the EXO-26® is not difficult, but regular practice is important.

ordinary sport scuba diving, the level of complexity is no worse than that found on many technical dives. In fact, in surface supplied diving the diver is encumbered with far less equipment on his body than the average technical scuba diver.

In the commercial diving industry, it is generally accepted that surface supplied diving is much safer than diving with scuba. Unfortunately, there is no way to do a direct statistical comparison between sport scuba and surface supplied commercial diving to verify this. With few exceptions, most commercial diving companies prohibit the use of scuba for working dives. However, my experience in working for SubSea International, a large and well respected international commercial diving company, is that the accident rate for commercial divers is actually quite low. Most of the fatalities that I know of in commercial diving were industrial accidents, rather than diving accidents.

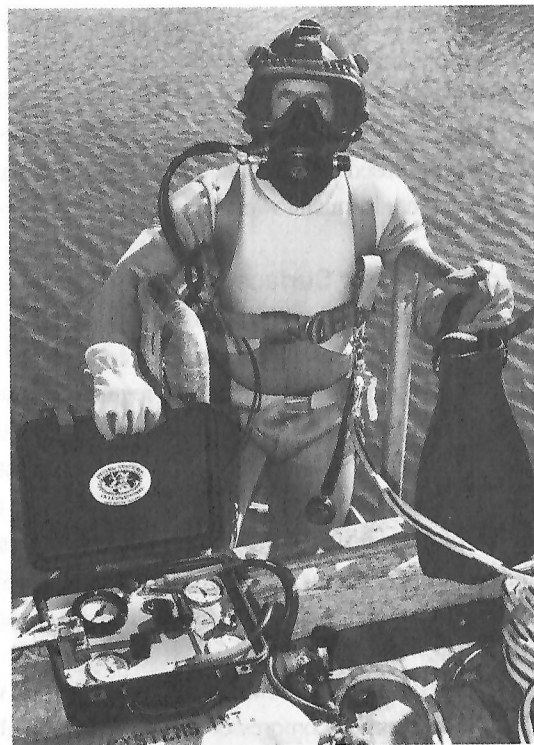
Probably the only situation where surface supplied diving isn't practical is in an extended cave diving penetration. The length of hose required for this type of diving would be impossible to handle. Also, in extended wreck penetrations it's advisable to have a standby surface supplied diver underwater at the entrance to the wreck to tend the hose of the diver who is going inside. In commercial diving this is both an OSHA (Occupational Safety and Health Act) and U.S. Coast Guard requirement.

Learning to use surface supplied diving equipment for air diving is not difficult. You can learn the basics of this type of gear in a few days. Of course, there is no substitute for using the gear on a regular basis to become skilled and confident in its use. Diving with the equipment is not much different from diving with scuba, but learning how to set up the equipment and run the system topside are what is most important.

Using surface supplied gear for mixed gas diving is not much more complicated than using the systems designed for air diving. Obviously, you must have a good understanding of the mixed gas diving tables and the procedures that must be followed to do this type of diving with any degree of safety.

The most serious mistake made by most dive teams who use surface supplied diving equipment is that they don't use it frequently enough to maintain their familiarity and proficiency with the equipment. This is

especially true of search and rescue teams who dive infrequently. If you don't use the equipment often enough to become comfortable with it, you will tend to put it aside and not use it at all. Not only is this not good for you, it also isn't good for the equipment. Equipment that is used regularly and properly maintained is both reliable and a trusted tool. Gear that has been sitting unused may not have been stored properly or rubber parts may have become dry and brittle. When the time comes for the gear to be used, because safety or some other aspect of the job demands it, you won't remember how to use it properly and mistakes are likely to be made.



**Fig. 6.2** You can put together a complete surface supplied diving system like this for well under \$5000.00. The manifold box shown here is the DCS-3®.

## Cost Factors

The economics of surface supplied diving can be more expensive than scuba, although the cost of outfitting a technical scuba diver for deep air diving comes close to that of surface supplied diving. You can put together a simple air diving system for surface supplied diving for under \$4800.00. This would include the EXO-26®, a bail-out bottle, manifold block and harness, an air diving manifold box for use with scuba, an umbilical, and communications box. Given the increased safety and productivity provided by this gear, this is not a lot of money. On an order of this size, price is usually somewhat negotiable.

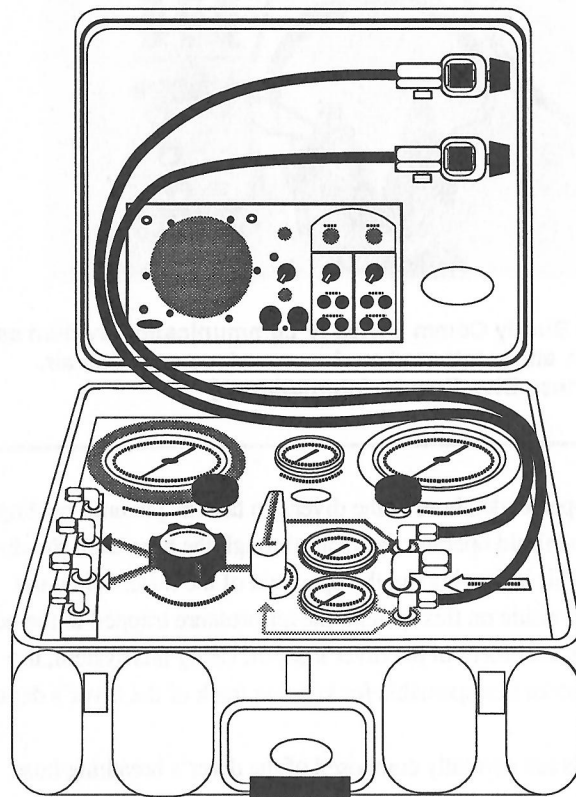
To put together a system for mixed gas diving would probably come closer to \$15,000.00. This might include a more sophisticated mask, like the Kirby Morgan Band Mask®, a longer umbilical, a mixed gas manifold, a bail-out system and harness, and a helium speech unscrambler. Gas costs for using surface supplied gear would be higher than for a closed circuit rig, but the safety and reliability of surface supplied gear is higher than it is for closed circuit. In addition, the maintenance factor for surface supplied gear is much lower than it is for closed circuit.

## Selecting Equipment for Surface Supplied Diving

Divers' breathing manifolds come in three versions. First, there are single diver systems that are designed to only use compressed air from a scuba bottle or other high pressure source. The regulator in the breathing air manifold functions like the first stage of a scuba regulator. These regulators are usually set for approximately 150 P.S.I. over bottom pressure and will adjust automatically for depth, provided the topside operator uses the pneumo system correctly. An example of this type of system would be Diving Systems International's (DSI) DCS-3®. This extremely compact manifold is packaged in a Pelican Case and fits under an airline seat.

More sophisticated air manifolds will handle 2 divers and will accept air from a low pressure compressor as well as from high pressure cylinders. DSI's Dive Control System-2® is designed like this.

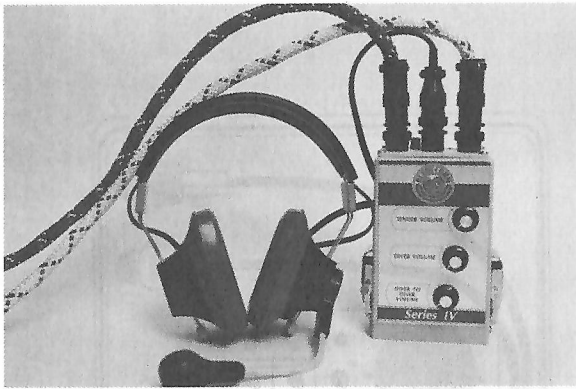
Mixed gas manifolds are designed to deliver large volumes of breathing gas at depth. At a minimum they include two high pressure, high flow regulators, at least one metering valve (for manually control-



**Fig. 6.3 This Dive Control System® can support two divers. (© Diving Systems International. All rights reserved.)**

ling the flow of mixed gas if both regulators fail), and an air line for accepting air from a low pressure compressor. Mixed gas manifolds are custom built by companies like Diver's Supply and Aqua Air Industries.

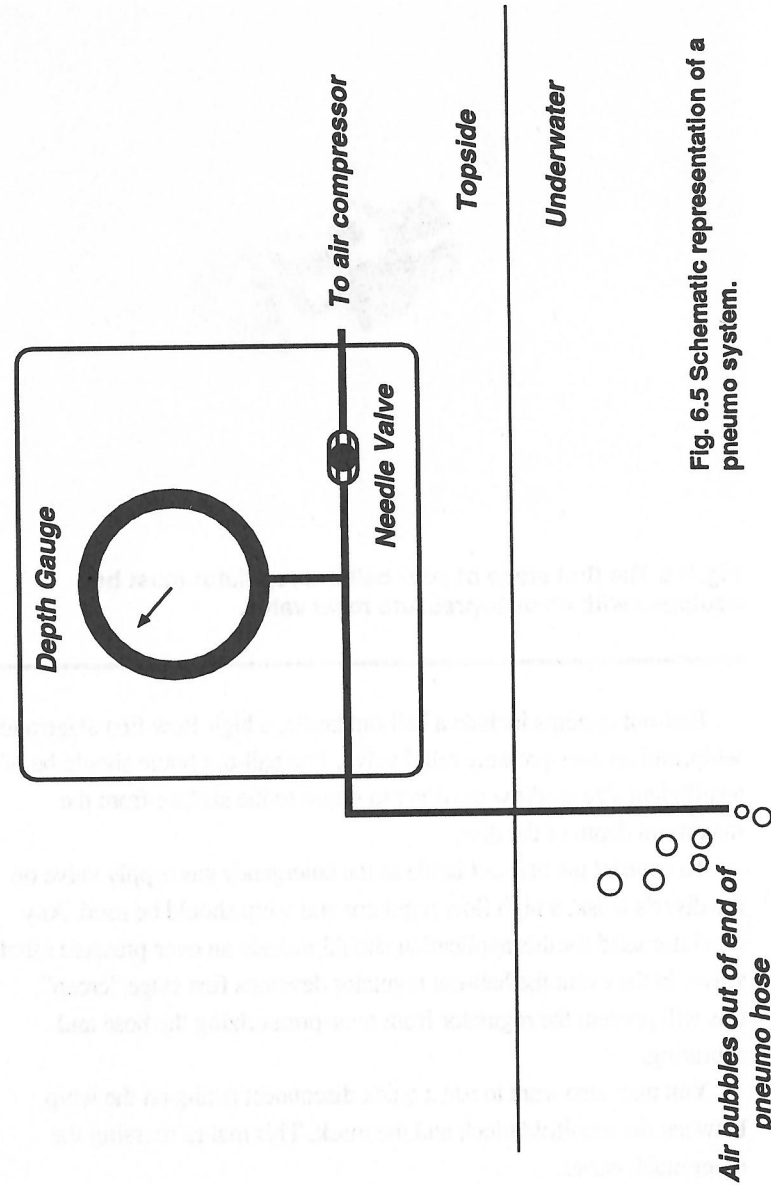
Most breathing manifolds are also equipped with a pneumofathometer system. This system is designed to measure the diver's depth. A small amount of breathing gas is diverted through a separate valve and highly accurate depth gauge. The gas then flows



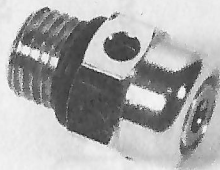
**Fig. 6.4** The Buddy Comm Series IV communication system can be used with either tethered scuba or surface supplied air. (Photo courtesy Dive Rescue International.)

down to an open ended hose at the diver. To take a “pneumo reading”, the topside manifold operator flows air through the hose until the diver confirms that air is flowing out the open end of the hose. When the valve is shut topside on this system, the air pressure trapped in the hose provides a measurement of the diver’s depth. Using this system, the manifold operator is responsible for keeping track of the diver’s depth and time.

Umbilicals are normally composed of the diver’s breathing hose, pneumo hose, and communications wire. A strength member is considered optional but highly desirable. Communications rope or Spiral 4 comm wire are considered stout enough to take the place of an additional strength member. The hose may be either floating or sinking hose, depending on the diver’s preference. For example, for penetrating a wreck where there is heavy silt inside, it would be preferable to use a floating hose. Other components that may be added to the diver’s hose include a hot water supply hose for use with a hot water suit, and television cable for use with closed circuit TV. Companies such as DECA Diving, Dive Rescue Int’l., Diver’s Supply, Marvel, and Aqua Tech can all supply umbilicals in any length you might specify.



**Fig. 6.5** Schematic representation of a pneumo system.



**Fig. 6.6** The first stage of your bail-out regulator must be equipped with an over-pressure relief valve.

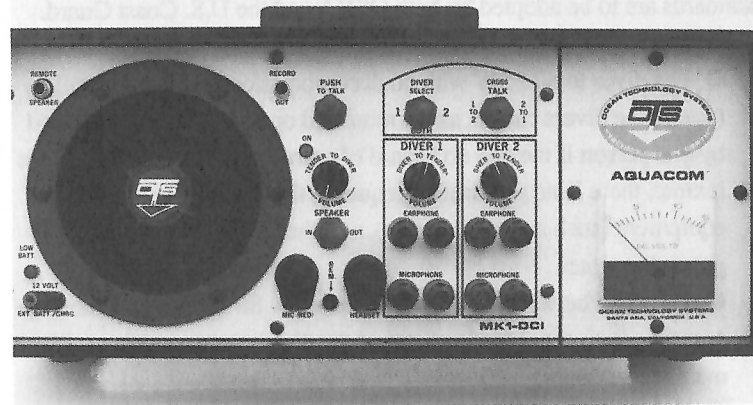
Bail-out systems include a bail-out bottle, a high-flow first stage and whip, and an over-pressure relief valve. The bail-out bottle should be of a sufficient size to allow the diver to return to the surface from the maximum depth of the dive.

To connect the bail-out bottle to the emergency gas supply valve on the diver's mask, a high flow regulator and whip should be used. Any regulator used for this application should include an over-pressure relief valve. In the event the bail-out regulator develops first stage "creep", this will prevent the regulator from over-pressurizing the hose and rupturing.

You may also want to use a quick disconnect fitting on the whip between the manifold block and the mask. This makes dressing the diver much easier.

The bail-out bottle normally mounts on the back of diver's harness. You can use a harness like DUI's Weight and Trim System, with some slight modifications, for this application.

The communications boxes used for air diving are identical to those used for tethered scuba. For mixed gas diving with helium you will



**Fig. 6.7** A two diver air diving communications box. (Courtesy of Ocean Technology Systems)

need to invest in a helium unscrambler. Helium unscramblers are sophisticated devices that make high pitched helium speech intelligible. In appearance, they are almost identical to air diving communications boxes, but are usually equipped with modulation switches to compensate for changes in pitch in the diver's voice at different depths.

Helium unscramblers are manufactured by Diver's Supply and Helle Engineering.

### The Surface Supplied Diving Team

At a minimum, the surface supplied diving team is made of the following crew members; a diver, a standby diver, a tender, and a manifold operator/supervisor. If you are diving with a single diver air manifold, like the DCS-3<sup>®</sup>, the standby diver can be equipped with tethered scuba rather than surface supplied gear, diving conditions permitting. In reality, every person on the team is a diver and rotates through each of the different roles during the course of a typical operation.



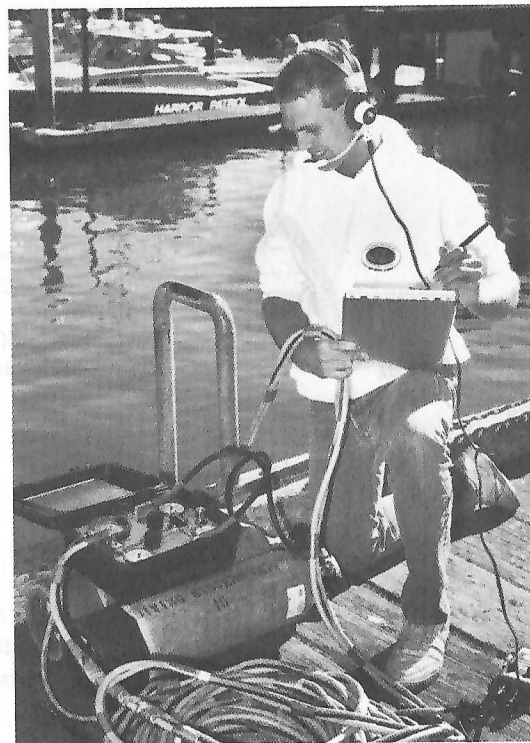
According to the standards established by the Association of Diving Contractors (ADC), the following are considered the minimum manpower requirements for surface supplied diving operations. These standards are to be adopted by both OSHA and the U.S. Coast Guard.

- For dives to 80 FSW with no decompression: 2 divers, 1 tender (one of the divers can act as the manifold operator) May be reduced by one person if there is no hazard of entrapment, the location is not remote, there is no penetration required, there is no topside tended equipment (such as welding gear), and there is not an extended air gap to the water.
- For dives between 80-130 FSW or below 80 FSW with decompression: 2 divers, 2 tenders (one of the divers can act as the manifold operator)
- For dives between 130-220 FSW: 1 non-diving supervisor, 2 divers, 2 tenders
- For mixed gas dives: 1 non-diving supervisor, 2 divers, 2 tenders, 1 life support technician

To dive with surface supplied diving equipment you must be an experienced diver. You must be comfortable in the water and have a good understanding of the surface supplied diving system.

Surface supplied diving is normally done with a single diver in the water at a time. For this reason, a standby diver is considered an essential member of any surface supplied diving team. The standby diver is always dressed in, with the exception of his mask, and ready to go to the aid of the diver in the water. This means that the standby diver has everything else in place and ready to go; fins, gloves, bail-out bottle, weight belt, etc. The standby diver must be capable of rescuing the diver if needed.

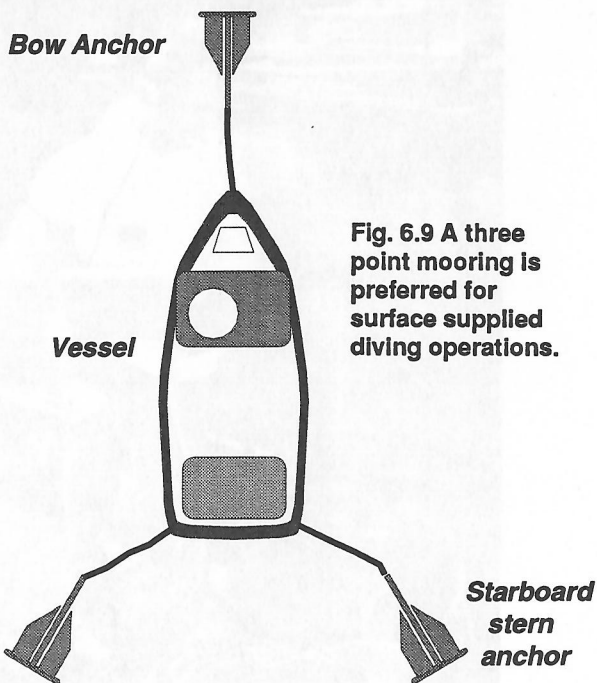
The tender on a surface supplied dive has many responsibilities. It is the tender's responsibility to help the diver get dressed, to assist the diver in and out of the water, and to tend the diver's hose. Tenders must never let go of the diver's hose. A truly experienced tender can tell exactly what the diver is doing just from the feel of the hose.



**Fig. 6.8 Manifold operators must be experienced divers, familiar with surface supplied diving operations.**

The manifold operator (supervisor) must be a highly experienced diver, well familiar with surface supplied diving operations. He holds the diver's life in his hands! A wrong turn of a valve could kill the diver. If the operation involves mixed gas, the manifold operator must understand the partial pressure tables and mixed gas decompression schedules.

Experienced manifold operators can tell the diver's state of mind by listening to what the diver says and the sound of the diver's breathing. Above all, the manifold operator must be capable of making the right decisions regarding the diver's safety.

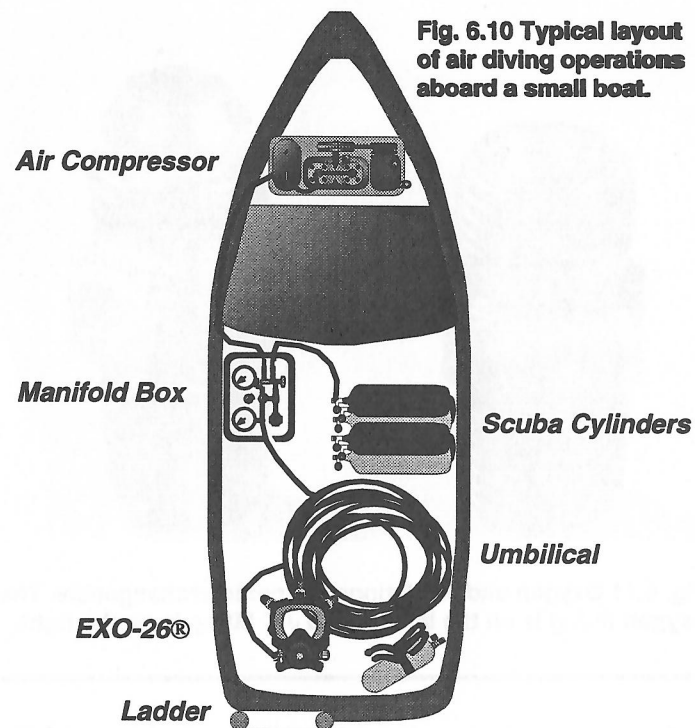


**Fig. 6.9** A three point mooring is preferred for surface supplied diving operations.

### Setting up for surface supplied diving operations

In a surface supplied diving operation you must have good teamwork between a number of people. To start, you've got a bit more gear than you would use during a scuba dive and it's a lot easier to set up with the right help. Setting the gear up correctly is essential to a successful operation. It's also important that everyone on the team participate in the set-up so people know where things are if you've got to find something in a hurry.

Surface supplied dives should be conducted from vessels that have a minimum two point mooring system, with a bow and stern hook. If at all possible, a three point mooring is preferred, with a single bow hook and two stern hooks, one off each side. Under no circumstances is a single bow hook acceptable. If the boat swings with the wind or drags anchor, a diver that is inside a wreck could be seriously injured or killed in this type of situation.



**Fig. 6.10** Typical layout of air diving operations aboard a small boat.

If you're using a low pressure compressor, you'll want to set it up away from the manifold operator so he can hear both the diver and communicate with the tender. The compressor must also be rigged so that the intake is upwind from the exhaust. Many times the bow of the boat is a good location for the compressor, provided it can be adequately protected from salt spray while traveling to and from the dive site.

Compressed gas bottles should be located within reach of the manifold operator if at all possible. This makes it possible for the manifold operator to change gas without leaving the manifold. At no time should the manifold operator leave the diver's breathing gas manifold unattended.

Logistically, surface supplied diving equipment does take more space than the equivalent gear for a scuba operation. You've got to have enough room for your air compressor, gas storage bottles, breathing gas manifold, and umbilicals. Most commercial companies will not make a



Fig. 6.11 Oxygen and JIC fittings are not interchangeable. The oxygen fitting is on the left and the JIC fitting is on the right.

surface supplied mixed gas dive unless they have a minimum of 10,000 cubic feet of gas available.

To set up your surface supplied system, the first thing you will need to do is to connect your topside air supply to the diver's breathing gas manifold. Even if you are using mixed gas for your bottom work, you will still need and want to use compressed air above 100 feet. If you are only using compressed air, it is a good idea to have a low pressure compressor that is either gasoline or diesel driven and high pressure bottles as a back-up. The engine driving the compressor should be fueled up prior to the start of each dive.

Whenever you are connecting hose fittings be sure to use two wrenches, one wrench on each of the two fittings to be connected. This will allow you to make a good connection without damaging either of the fittings.

After you have connected your topside air supply, the next step would be to connect your umbilical. There will be three connections that you will need to make. These connections are the diver's breathing air

hose, the pneumofathometer (depth sensing hose), and the communications wire. Both the breathing gas hose and the pneumo hose (short for pneumofathometer) will be equipped with brass straight thread fittings.

Before you can connect the hose you will need to remove the protective caps on the ends of the hose. These caps should always be installed on the hose when it is not in use to keep dust and other foreign matter out of the breathing system. If you lose the caps you can always seal off the ends with a couple wraps of electrical tape.

The most common connection for the hoses will be an 9/16 inch oxygen fitting, although another type of fitting known as a JIC (Joint Industrial Conference) fitting may be used. These fittings are *not* interchangeable. You need to know which type of fitting your manifold box uses and that the fittings on your hose are compatible. It is very important to only tighten the fittings until they are snug. If you overtighten the fittings you will deform them, causing them to crack and leak.

Always be sure to use the right size wrenches for the fittings that you want to connect. Do not use adjustable wrenches. Adjustable wrenches tend to slip and will deform soft brass fittings. If an adjustable wrench slips too many times, eventually it will not be possible to tighten the fitting because the edges will become rounder. Use the correct size wrenches to avoid this problem.

The topside connection used for communications system is usually an inexpensive "banana plug," named for its shape. This connector simply slips into the female connector on the communications box.

After you have connected the diver's hose to the manifold, blow out the hose before you connect it to the bail-out valve on the diver's manifold block. Blowing out the hose is an extra precaution. Even if your hoses have been capped, the wise diver will always take this step to doubly ensure there is nothing in the hose that could block the breathing gas.

With the hose purged of any dust or other contaminants, connect the hose to the male fitting on the manifold block. The EXO-26® should already be connected to the manifold block using a low pressure scuba regulator hose. Screw the adjustment knob on the mask all the way in (towards the regulator) and turn the air on at the Dive Control System®.

There should be no breathing gas escaping from the mask. Hold the mask up to your face and test the breathing system.

Screw out the adjustment knob and make sure it turns freely. Screw the knob out until the mask just begins to free flow and then screw it back in half a turn.

Mate the waterproof connector on the mask to the connector at the end of the umbilical. The best way to test the mask is to have one of your team mates operate the topside communications box while you hold the mask up to your face. With the box turned on you should be able to communicate easily. Make sure that both earphones are functioning properly.

You can test the communications by yourself by turning on the topside box, positioning the mask within hearing distance of the box, and tapping on the microphone in the mask. You should be able to hear the sound easily. Be sure to point the mask away from the box to avoid annoying feedback. With the volume to the diver turned up, tap on the speaker on the communications box and you should be able to hear the sound of tapping from the earphones in the mask.

### **Dressing in for the Dive**

Prior to donning the mask you should have all of your other equipment on, including your fins. The last equipment that you should don will be your harness, bail-out bottle, and the mask.

Your tender should hold the bail-out bottle with its harness and the mask so that you can slip into the bail-out bottle easily. Once the bottle is on your back, take the mask from the tender so he can make the remaining connections and adjustments for you. Make sure the harness is snug.

It is standard practice for the diving umbilical to be fitted with a stainless "D" ring that connects to a stainless steel snap hook on the harness, just as you would do for tethered scuba. This helps to avoid topside putting a direct pull on the diver's mask.

The bail-out bottle is usually turned on at the bottle, but off at the manifold block. In surface supplied diving the bail-out bottle is always equipped with a submersible pressure gauge. The gauge is normally tucked through the harness at the diver's chest. Be sure to check the pressure in the bottle before you enter the water.

Just before you don the mask, be sure to have your tender apply a thin film of soap or other anti-fog solution to the lens. It's easy to forget this step in the excitement of a dive, but it can make the difference between an enjoyable dive and a miserable one.

Your tender should guide you to your entry point with a firm hand on your harness. This is essential since your vision will be somewhat limited once the mask is on your face.

### **Diving Procedures During a Surface Supplied Dive**

During a surface supplied diving operation it is the responsibility of the first diver in the water to establish a "downline" to the job site. The downline provides a descent line for subsequent divers and provides an ascent line and a place to hang off for decompression. The downline can also be used to send tools or other materials to the diver. Attach a large "running shackle" to the downline that can run on the line and use a messenger line attached to the running shackle to lower or raise objects to and from the bottom.

As soon as you hit the water on a surface supplied dive, the first thing you must do is to check out your breathing system and make sure everything is functioning properly. When you are ready to leave the surface, tell topside, "Diver leaving the surface." Even if you are diving with a dive computer, topside should keep track of your bottom time as a back-up. If you are diving with mixed gas, your decompression will be run from topside and you must inform topside whenever you are moving deeper or shallower. This is essential.

If you are not the first diver in the water, and the downline has already been established, be sure that you do not spiral around the downline as you descend. If you do, your hose will be tangled in the line and it will be impossible to make a direct ascent to the surface. You must descend and ascend on the same side of the line.

When you descend on a surface supplied mixed gas dive topside gives notice to the diver when the switch to mix is made. You then ventilate the mask to purge the umbilical of air using the free flow on the mask. As the mix enters the breathing system an audible shift in the sound of the gas entering the breathing system provides a signal that the gas has reached the diver. You should be able to hear when this takes place and the manifold operator should be able to hear it by listening to



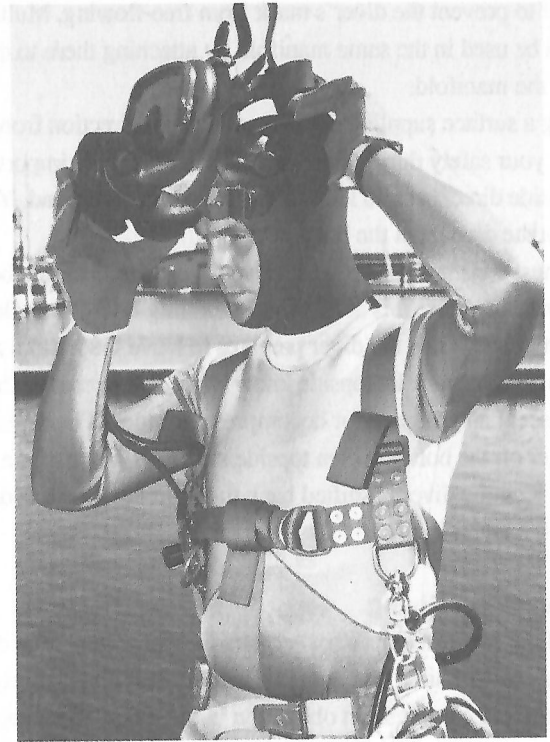
**Fig. 6.12 Always test the communications between the mask and the communications box before the diver dons his equipment.**

the communicator. Of course, your voice will change as soon as the gas reaches you and you'll sound very much like Donald Duck.

As the diver, you must always be aware of the location of your umbilical. Unlike the tethered scuba diver, you do not have the luxury of disconnecting yourself from your umbilical if it becomes entangled. For this reason, you must always go over any obstruction so that you always have a clear ascent path to the surface. In addition, you must learn to dive with the absolute minimum amount of hose slack.

The tender needs to be prepared to send any tools down to the diver that may be needed during the course of the dive. These can be sent down via a messenger line attached to the downline with a running shackle. The messenger line controls the descent of the object being lowered to the diver, so it doesn't go crashing to the bottom. The running shackle slides down the hose and can be pulled back up the down line with any items that need to be sent back to topside.

In an air diving operation, the manifold operator has three primary responsibilities. These are to make sure the diver is getting the right air



**Fig. 6.13 A stainless steel snap hook is used to attach the umbilical to the diver's harness, as can be seen here below the diver's left arm.**

pressure for the mask to function properly, to make sure that there is a sufficient air supply for the remainder of the dive and any emergencies, and to keep track of the diver's depth and bottom time.

In a mixed gas diving operation, the manifold operator switches the diver from air to gas at the depth specified by the dive tables being used. The switch is easily made by closing the air valve and opening the ball valve on the mixed gas supply to be used. The regulator for the mix on line should be pre-set to the appropriate pressure for the shallowest depth where the diver will start using the mix. As the diver moves deeper, the manifold operator loads the regulator to a higher pressure. When the diver ascends at the end of the dive the regulator(s) must be

backed off to prevent the diver's mask from free-flowing. Multiple mixes can be used in the same manifold by attaching them to different "legs" on the manifold.

During a surface supplied dive you must take direction from topside regarding your safety during the dive. This is especially important. When topside directs you to leave bottom, you must respond. You cannot run the dive from the bottom.

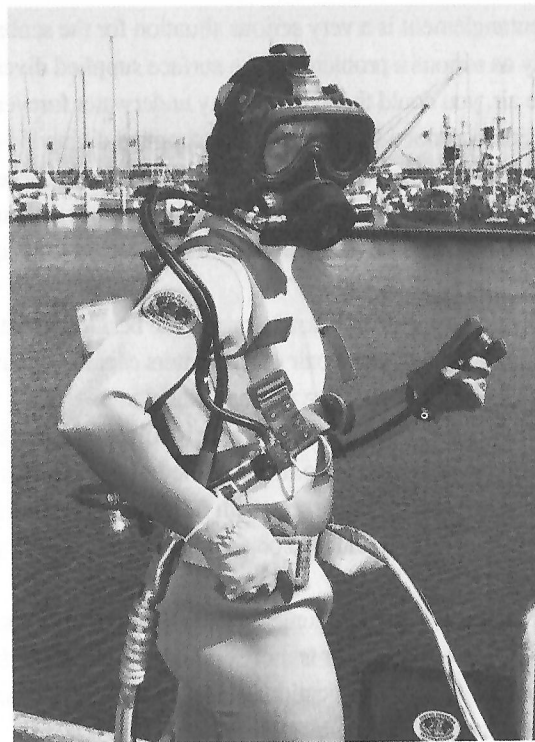
You must constantly keep track of your hose while on the bottom and be aware of where it is at all times. Learning how to handle your hose is a real art. When the diver prepares to leave the bottom at the end of the dive he must let topside know when that occurs so they can time the ascent and prepare for decompression stops. The diver must never linger on the bottom when topside says it's time to come up. The depth at which the diver is shifted back to air on the ascent is determined by the tables in use.

### Decompression Diving

One of the big differences between traditional commercial diving techniques and technical diving is that commercial divers rarely ever complete their decompression obligation in the water. Commercial divers use a procedure known as surface decompression on oxygen, or "sur-d-O<sub>2</sub>" as it's more commonly known.

In sur-d-O<sub>2</sub> diving, at the end of the dive, the diver ascends to his first water stop and begins his decompression. Depending upon the depth and duration of the dive, the diver does several water stops, then surfaces and is recompressed in a recompression chamber to a depth of 40 feet where he completes the balance of his decompression on pure oxygen. This is a much safer method of completing decompression, since the diver is in a controlled environment.

Most commercial diving companies do not do in-water decompression on pure oxygen. The reason for this is very simple. Even if all your o-rings are O<sub>2</sub> compatible, even if you have used O<sub>2</sub> safe lubricants, and even if your hose has been O<sub>2</sub> cleaned, the minute you use an oil lubricated air compressor in your breathing system you must consider that your equipment has been contaminated. Most commercial divers take the subject of oxygen fires very seriously. I personally know of two divers who have been severely injured as a result of oxygen fires.



**Fig. 6.14** Be sure to check the pressure in the ball-out bottle before you enter the water.

---

Some commercial companies are using nitrox to speed decompression. There is no one standard procedure for this technique. If you decide to employ these techniques you must be willing to accept responsibility for any accidents that may occur.

### Emergency Procedures

While any underwater emergency is serious, in most situations they can be dealt with more effectively when the diver is using surface supplied gear than with scuba. In fact, most commercial diving companies do not allow their personnel to use scuba except under very narrow and controlled circumstances. They do not consider scuba to be a serious working tool.

While entanglement is a very serious situation for the scuba diver, it is not nearly as serious a problem for the surface supplied diver. As long as you have air, you could theoretically stay underwater forever, if decompression was not a factor. In surface supplied diving if you get hung up on an obstruction (fouled) there is usually not the urgency to get untangled that there is with scuba. With the unlimited air supply available for the surface supplied diver, you have lots of time to get yourself free.

Aside from carrying a sharp knife, one of the best tools that you can carry with you underwater is a pair of sidecutters capable of cutting wire. These can be quite effective in many situations.

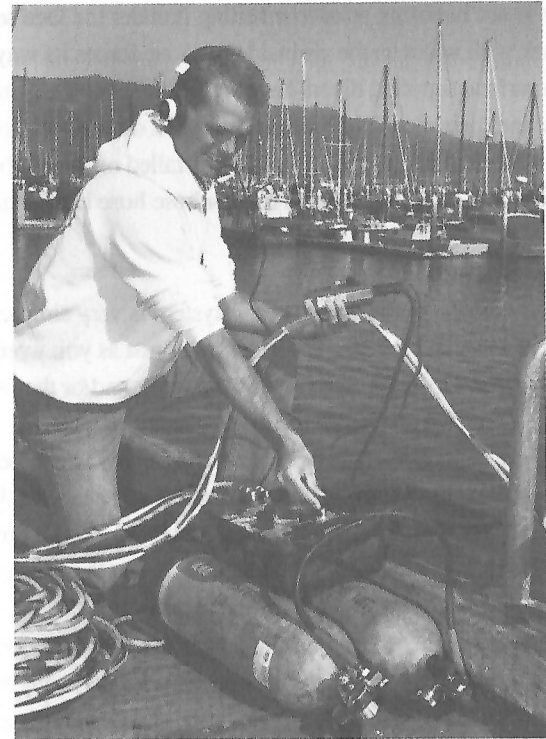
Most commercial divers do not carry their knives on their legs like sport scuba divers are prone to do. Instead, they usually carry a folding knife that is attached to their harness with a short lanyard and a snap hook. Ideally, the knife should also be equipped with a marlin spike for opening shackles.

While it is rare to lose communications in the middle of a surface supplied dive, it does happen. It is more common to discover that there is a problem with the communications at the start of the dive and to correct it then, than for communications to suddenly fail.

When communications are lost it is possible to use line pull signals to get the diver back to the surface, but the dive should not be continued unless a life is at stake. The standard procedure in the commercial industry is to abort the dive and correct the problem. Standard line pull signals are listed in the appendix and every diver who uses surface supplied diving equipment should know them.

Dealing with a flooded mask while using surface supplied diving equipment is no different than dealing with it on scuba, provided the mask is intact. In the uncommon situation where the face port is broken it becomes a more serious emergency since the diver does not have a separate mouthpiece. In addition, surface supplied divers do not normally carry a back-up scuba rig with a separate regulator.

If the face port is not broken, then the mask may be cleared as you normally would by using the purge button. However, if the face port is broken, you can still get something to breathe if you keep your face down and pointed towards the bottom. This will trap air in the mask. Obviously, the dive must be aborted immediately.



**Fig. 6.15** The diver must take direction from topside.

When you are properly rigged for surface supplied diving the loss of your main air supply can be handled fairly easily, provided your bail-out bottle is suited to your depth and you have no decompression obligation. All that should be necessary in most situations is to turn the emergency valve at the manifold block on and ascend.

In a situation where your breathing hose has ruptured but there is still breathing gas at the topside manifold it is possible to use the pneumo hose as an alternate air source. Since the pneumo hose is open ended it can be used to free flow air into the mask. To do this, the diver needs to call for topside to supply air to the pneumo. Once the hose is bubbling it can be inserted under the bottom edge of the face seal. You must be certain the hose is bubbling before you insert it in the mask since the hose will be full of water until gas starts to come out the end.

If the hose is not bubbling prior to inserting it under the face seal it will fill the mask with water as the air inside the hose forces its way out.

If both surface supplied divers have rigged the connection between their mask and their manifold blocks with quick disconnect fittings, and they have a spare quick disconnect fitting installed on their blocks, the standby diver can provide air to the diver whose hose has ruptured.

### Post-Dive System Breakdown

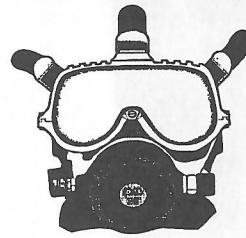
After the dive the maintenance of the system is very simple. First, the umbilical must be bled of any breathing air just as you would purge a scuba regulator. Open the free flow on the mask and/or the pneumo valve on the manifold and allow the remaining air to vent.

When there is no gas left in the system the umbilical can be disconnected from the manifold and the mask. Cap or tape both ends of the umbilical so that no foreign matter can enter the diver's breathing hose. Cap the fittings on the manifold block and cap the hose on the mask if you have disconnected it from the manifold block.

Be sure to remember to turn off the power to the diver's communicator. If the communicator uses disposable batteries they may need to be replaced prior to the next dive. Many communicators today use rechargeable batteries and will take a trickle charge. Check the manual supplied with the communicator to see how it should be treated.

The diver's umbilical should be rinsed with fresh clean water. Be sure to wipe down the manifold box with a clean, damp rag and dry it.

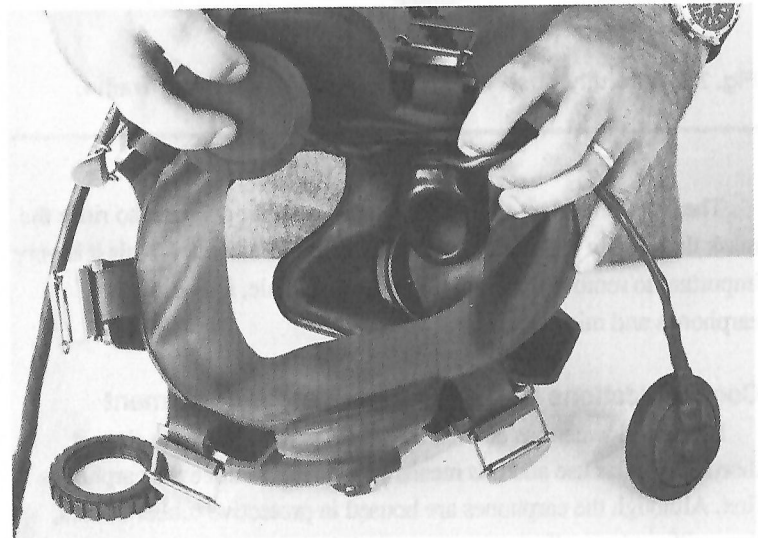
Check the bail-out bottle to be sure that it is full. There is a dangerous tendency to allow the pressure in the bail-out bottle to drop a little bit between diving days. The bail-out bottle should always be completely full: you must not use a bottle that is less than 100% full.



# Chapter 7

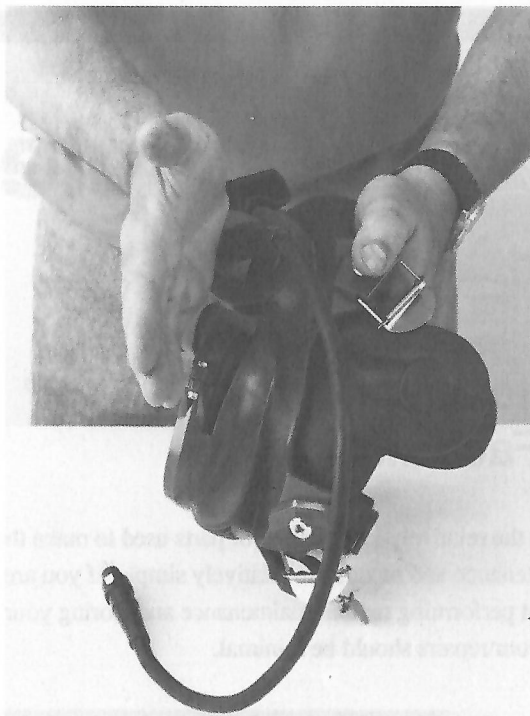
## Maintenance of the EXO-26® Full Face Mask

Due to the relatively low number of parts used to make the EXO-26®, maintenance and repairs are relatively simple. If you are conscientious about performing regular maintenance and storing your mask properly your repairs should be minimal.



**Fig. 7.1** The position of the microphone cup is very important. It must be exactly as it is shown here.





**Fig. 7.2 Carefully push the module through the mask frame.**

---

The most important thing that you can do after diving is to rinse the mask thoroughly with fresh water. However, before you do this it is very important to remove the communications module, including the earphones and microphone.

### **Communications Module Removal and Replacement**

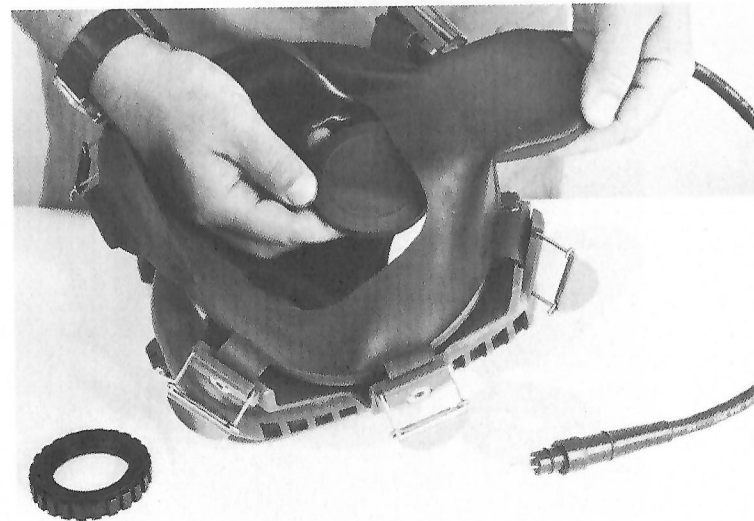
Even if no water has entered the mask, you will want to rinse it thoroughly after use and this means you should remove the earphones first. Although the earphones are housed in protective rubber covers, they will not keep all of the water out of the communications components. For this reason, it's a good idea to remove the communications module prior to rinsing.

To start removal, unscrew the mount ring (nut) from the outside of the module. Once it has been unscrewed, slide the ring over the waterproof connector until it is clear of the mask.

Note the position of the rubber microphone cup inside the mask before you continue. The purpose of the cup is to direct your voice into the microphone. When you reinstall the microphone cup it must be positioned the same way for the microphone to work properly.

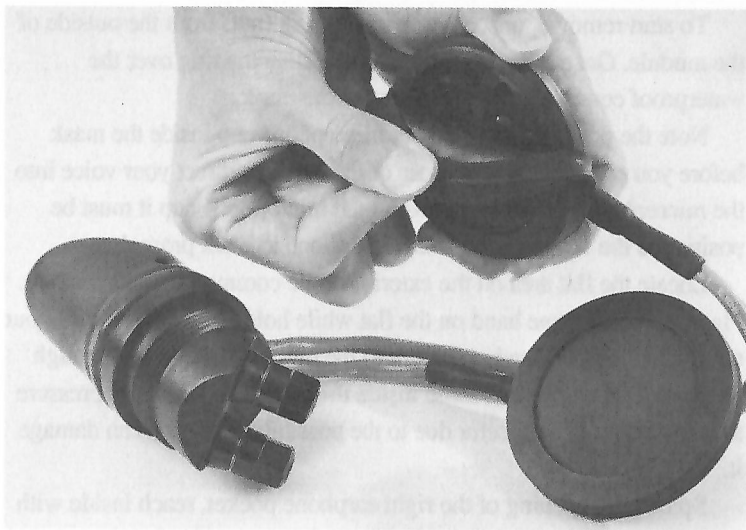
Locate the flat area on the exterior of the communications module. Place the heel of one hand on the flat while holding the mask with your other hand. Apply steady pressure to the module and push it through the mask frame until it is loose inside the mask. Do not apply pressure to the waterproof connector due to the possibility that you can damage it.

Spread the opening of the right earphone pocket, reach inside with your thumb and forefinger, and grab the earphone. Hold the exterior of the earphone pocket with your free hand. Pull the earphone out of the pocket with a firm steady pull. Do not pull the earphone by the wire or you may damage the connection between the wire and the earphone.

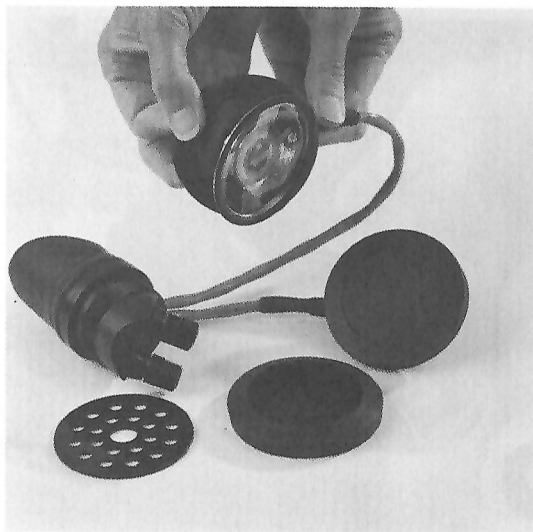


**Fig. 7.3 Removing the left earphone from the mask.**

---



**Fig. 7.4 Peeling back the earphone cover.**



**Fig. 7.5 Exposing the earphone.**



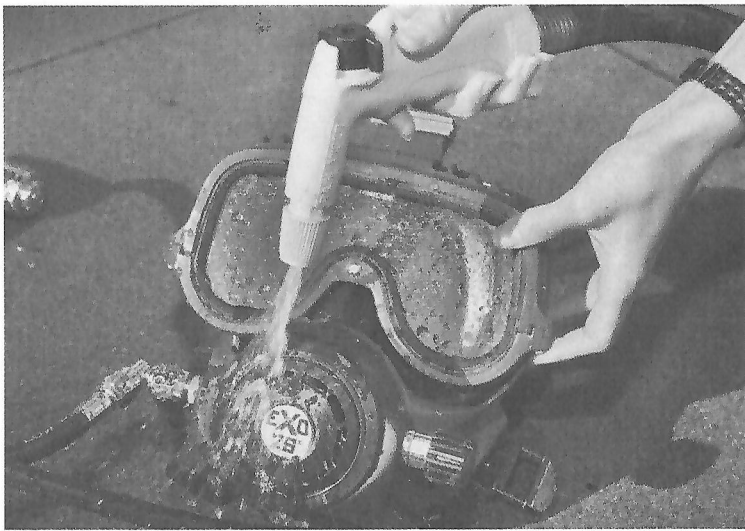
**Fig. 7.6 Remove the air delivery tube prior to rinsing.**

Remove the left earphone by the same technique. The entire communications module can now be separated from the mask.

If there was water in the earphone pockets, be sure to peel the rubber covers back from the earphones themselves. This will expose the earphones and allow them to dry. This will not usually be necessary unless the mask was completely flooded. After the earphones have dried, replace the rubber covers.

To replace the communications system, install the left earphone first. If you moisten the earphone cover first with a small amount of the pump silicone it will be easier to slide the earphones into the pockets. Hold the left earphone by the edge of the rubber cover and push it gently into the pocket while holding the mask by the pocket. Support the weight of the mask on a work bench or table. Once the left earphone has been installed, insert the right earphone.

Feed the waterproof connector through the opening in the mask frame. Rotate the microphone until the microphone cup is oriented towards your mouth so it will pick up as much of your voice as possible.



**Fig. 7.7 Rinsing the mask.**

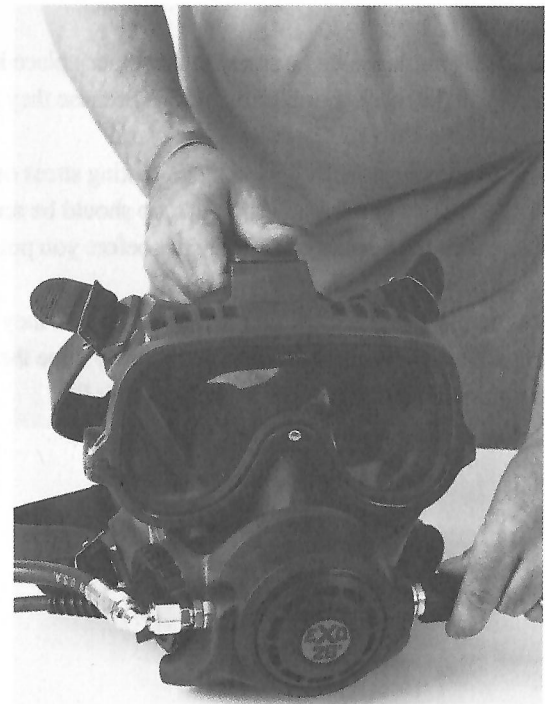
Slip the mount ring (nut) back over the waterproof connector and thread it back onto the communications module. Tighten the mount ring until snug. The module is sealed by the ring compressing the face seal.

### **Rinsing Procedures**

Prior to rinsing, you will also want to remove the air delivery tube and the foam insert that lies underneath the edge of the face seal. To remove the tube, start at the regulator opening inside the mask and pull it away from the flange. Continue pulling the tube until it is free of the mask. The foam insert can be found underneath the inner edge of the face seal and is held in place by Velcro. Simply pull it out of the mask.

Use fresh water to rinse both the inside and the outside of the mask. You may also rinse the air delivery tube and the foam if needed. While you are rinsing the mask screw the regulator knob in and out several times as you run water over it to dislodge any salts.

Allow the mask to air dry or you can blow it dry with compressed air. Due to the angles inside the mask, you will probably need to turn



**Fig. 7.8 Screw out the adjustment knob prior to storage.**

the mask over to shake water out. In particular, make sure the earphone pockets are dry prior to reinstalling the earphones.

To reinstall the air tube start by tucking the top end into the groove at the top of the mask. Work it into the groove all the way down the left side of the mask. Snap the end of the tube on the flange inside the regulator at an angle to get it started then push the remaining portion into the groove.

The foam insert tucks back under the face seal with the ends held in position by the earphone pockets. The foam must be completely dry before you put it back into the mask.

## Proper Storage

Your EXO-26® mask should be stored in a cool, dry place in its own bag. Avoid storing the mask near electric motors because they generate ozone that can damage the rubber parts of the mask.

The mask is best stored face down to avoid putting stress on the earphone pockets. The regulator adjustment knob should be screwed all the way out. Be sure the mask is completely dry before you put it away for any long term storage.

Test the communications when they are dry to be sure they are still working properly. It's also a good idea to periodically wipe the rubber parts of the mask with pump silicone to prolong their life.



# Chapter 8

## Field Repairs for the EXO-26® Full Face Mask

The EXO-26® is an exceptionally reliable piece of equipment and the need to repair it is infrequent. Without special training, the two components that are considered field replacements are the communications system and the spider. All major repairs should be performed only by a properly trained technician qualified to work on the EXO-26®.



**Fig. 8.1** Removing the microphone from the DSI communications module.

## Communications Components

When the communications system fails, unless you are dealing with a failure in the communications wire or one of the waterproof connectors, usually you will only need to replace a single component. For example, a single earphone may fail or the microphone may die.

The simplest and fastest way to replace communications if you are in the middle of a diving operation is to replace the entire module, microphone, and earphones, as outlined in *Chapter 7*. With practice, this job can be done in well under 3 minutes. For this reason, a complete spare communications module with earphones and microphone should always be carried with your equipment during any critical operation.

In a situation where there is no rush to get the diver in the water, and you have the time to replace individual components, repairs will still take only a few minutes. The only tool you will need is a flat blade screwdriver.

Remove the communications module from the mask and lay it out on a clean work surface. Remove the rubber microphone cup and set it



**Fig. 8.2** Loosening the screws that hold the communications components in the module.

aside. This will allow you to pull the microphone out of the communications module. The microphone is normally held in place with a bit of glue and will not to be gently pried out of the module.

Take note of how your communications components are connected since you will want to replace them in the same configuration. There is a difference in wiring between two wire systems and four wire systems. In a two wire system, both earphones and microphones are connected to the same two posts. In a four wire system, the earphones are connected to two posts and the microphone is connected to another two posts. Whether you are using a two wire or a four wire system, both the wires from any one component cannot be connected to the same post. This mistake creates a short circuit and the communications will not work. After you have removed the microphone from the communications module, loosen the screws holding the terminal lugs at the end of the wires for the earphones and microphone. With the screws removed, replace any individual components that are not working properly. Reinstall the components, thread the screws back into the module, and tighten until snug. Do not overtighten the screws or you will strip out the threads in the module. Test the communications prior to installing the module back into the mask.

Individual speakers can be disconnected by using a soldering iron where solder is used to make the connection. They must be reinstalled exactly as they come from the manufacturer.

Reassemble the module with the microphone and its cup. You can use a bit of silicone sealant to glue the microphone back into the module. Allow the sealant to set up overnight. Reinstall the communications module in the mask once the sealant has cured. In an emergency, you can use a bit of tightly wrapped electrical tape to hold the microphone in the module. If you use electrical tape, you must be sure that you can correctly install the microphone cup.

## Replacing the Spider

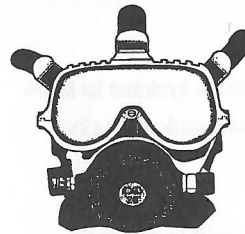
With proper care, the rubber components of the mask should last for many years, although if the mask is used heavily or in demanding environments they may last less than a year. The worst thing you can do is to leave the mask lying unprotected in the sun for extended periods of time.

Even with proper care, the rubber components will begin to break down over time. Both the face seal and the spider should be inspected prior to every dive to ensure that they are in proper working condition. If they are worn or cracked they must be replaced prior to diving.

Replacing the face seal is a job for a trained technician, but any diver should be able to replace the spider on his own mask. All that is required is to pinch the end of each "leg" of the spider and feed it through the buckle. To install the new spider, put a little pump silicone on the end of each leg, pinch the end, and feed it through the appropriate buckle.



Fig. 8.3 Replacing the spider.



# Glossary

***bail-out bottle:*** A scuba bottle worn by a diver that is used as a back-up to the diver's primary breathing supply.

***bare wire system:*** A communications system used in diving where the ends of the wires that connect to the diver's mask or helmet have no waterproof connector. The bare wire is exposed and makes the connection.

***carbon dioxide:*** A gas that is a component of air and is the by-product of respiration. Carbon dioxide is designated in the scientific world by  $CO_2$ . Carbon dioxide also stimulates the body to breathe.

***closed circuit:*** Diving equipment that is designed to recycle the diver's breathing gas. The diver breathes and rebreathes the breathing gas. The gas is cleansed of carbon dioxide by a chemical, usually soda sorb.

***communications box:*** An electronic device that allows a diver to communicate with personnel topside via a hard wire connection. The complete system works similar to a telephone. The communications box has a speaker and volume controls for both the diver and topside.

***communications module:*** A complete system of microphone and earphones that can be replaced as a single unit in the EXO-26® Full Face Mask.

**contaminated water:** Water that contains unwanted pollution, either biological, chemical, or nuclear.

**cross-talk:** A feature of a hard wire communications systems to allow two divers to speak with each other via a single communications box located topside.

**dead air space:** Biological or mechanical space within a diver's breathing system where there is no exchange of oxygen for carbon dioxide. Dead air space allows carbon dioxide to accumulate within a breathing system.

**diver's harness:** A stout harness that fastens around the upper torso with straps that go over the shoulders and around the chest. The harness is equipped with "D" rings where tools can be attached.

**diving helmet:** Breathing apparatus designed to enclose the head completely and to provide air underwater.

**double exhaust:** A special exhaust system for a diving helmet where two valves are stacked, one after the other, to prevent any backflow of contaminants into the helmet.

**downline:** A line that connects the dive station on the surface to the underwater work site. The downline is used by the diver to make his descent and ascent. It also helps to provide a way to send tools down to the diver.

**face seal:** A flat, wide sealing surface used in a full face mask to keep water out of the mask.

**four wire system:** A communications system that uses four wires so that separate sets of wires can be run to the earphones and microphone. Four wire systems function like telephones and both topside and the diver can speak simultaneously.

**full face mask:** A diving mask that covers the diver's entire face, rather than just the nose and mouth. The full face mask must include a regulator for breathing.

**half-mask:** A breathing mask designed to cover only the diver's mouth and chin. It does not fit in the mouth, but covers it so the diver does not need to grip a regulator in his teeth.

**hard wire communications:** An underwater communications system similar to a conventional telephone where the sound is transmitted over electrical cables.

**helium unscrambler:** A topside electronics box that is designed to convert a diver's speech that has been distorted due to breathing helium/oxygen gas mixtures into intelligible speech.

**intermediate pressure:** The pressure between the first stage of a scuba regulator and the second stage.

**low pressure compressor:** A compressor designed to supply large volumes of air at relatively low pressures, under 500 P.S.I. This type of compressor is used for surface supplied diving.

**manifold block:** A machined brass block that provides a junction for breathing gas for a surface supplied diver. The topside air supply and the bail-out supply are both connected to this block and the diver can choose either supply. Usually worn on the diver's harness. May also be referred to as a bail-out block.

**manifold operator:** A member of a surface supplied diving crew who operates the diver's air manifold topside. The manifold is used to control the supply of breathing air to the diver through his umbilical.

**metering valve:** A valve that provides very precise control of a gas.

**messenger line:** A line used with a running shackle and a downline to send tools or supplies to a diver working underwater.

**mixed gas:** Any mixture of compressed gases specifically formulated for a particular depth. Nitrox is a mixed gas as is heli-ox (helium and oxygen mixture).

**oral/nasal mask:** A small breathing mask that only covers the nose and mouth. May be contained within a diving helmet or full face mask as a means of avoiding carbon dioxide build-up and to improve communications.

**penetration dive:** Any dive that takes place within an enclosed space, whether it is a shipwreck, cave, or other structure.

**pneumo:** Short for pneumofathometer.

**pneumofathometer:** A depth sensing system that is based on hydrostatic pressure. It consists of a pressure gauge, an air supply, a valve, and a hose.

**“push-to-talk” system:** A two wire communication system for diving that provides communication for a tethered scuba diver or a surface supplied diver. For topside to speak to the diver they must key a switch. When topside is speaking, they cannot hear the diver.

**quick disconnect:** A type of breathing gas fitting that is spring loaded. It consists of two parts, a male connector and a female connector with a sleeve lock. Some quick disconnects are equipped with a locking feature.

**running shackle:** A large shackle that is attached to a downline that is allowed to slide down the line but is controlled by a messenger line. Used to send materials, tools, etc. to a diver working underwater.

**scientific diver:** A diver who works underwater solely for the purpose of collecting information or scientific samples. Scientific divers do not engage in construction work of any kind.

**spider:** A head strap arrangement that is used on full face masks. The typical spider has five “legs” that meet at a piece of rubber or other material that cups the back of the head.

**stage bottle:** Extra bottles of breathing gas that are carried by a scuba diver for use during the dive or for decompression purposes.

**standby diver:** A diver who is dressed in and ready to dive who waits topside to assist the diver who is in the water in the event of an emergency.

**sur-d-O<sub>2</sub>:** Decompression technique commonly used by commercial divers for the purpose of shortening water stops during a decompression dive. Typically, the diver completes one or two short water stops, then exits the water and enters a decompression chamber for continued decompression on oxygen at a depth of 40 feet.

**surface supplied diving:** Diving mode where all of the diver’s breathing gas is supplied from the surface through a hose.

**technical diving:** Recreational diving that exceeds the scope of sport scuba diving as recognized by the recreational diving training agencies. Technical diving typically includes dives that are of long duration, at deeper depths (over 130 FSW), or require decompression.

**tender:** Member of a diving team who is responsible for assisting a surface supplied diver in dressing into his gear and tending the diver’s hose while he is in the water.

**tethered scuba:** Diving mode where the diver uses a full face mask with scuba, but employs hard wire communications for speaking with topside.

**three point mooring:** A method of anchoring a vessel where one anchor is set from the bow and another anchor is set from each corner of the stern of the boat.



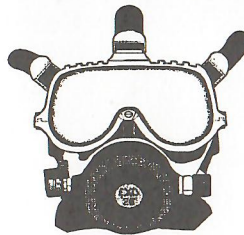
**two point mooring:** A method of anchoring a vessel where one anchor is set from the bow and another is set from the stern.

**two wire system:** A communications system where both the microphone and the earphone are wired to a single pair of wires. In a two wire system, the diver can only hear topside when they key a switch on the communications box.

**umbilical:** A bundle of hoses and cables used to provide air and communications to a surface supplied diver. Other hoses or cables may also be included in the bundle.

**waterproof connector:** A type of electrical connection that is designed to be used underwater.

**wireless communication:** A communications system designed to allow two divers to communicate by speaking with each other or topside, while underwater, with no connecting wires. Most wireless communications systems today are based on single sideband technology.



# Bibliography

Barsky, Steven M. *Diving in High-Risk Environments. Dive Rescue Int'l.* 201 N. Link Lane, Ft. Collins, CO, 80524. 1993.

Marine Marketing and Consulting and Ryan, Peter. *EXO-26® Full Face Mask: Operations and Maintenance Manual.* Diving Systems International, 425 Garden St., Santa Barbara, CA 93101. 1990.

Association of Diving Contractors. *Consensus Standards for Commercial Diving Operations: Fourth Edition.* Association of Diving Contractors, 2611 FM 1960W, Suite F-204, Houston, TX, 77068. 1992.



**PADI**  
INSTRUCTOR 33913  
Albrecht Salm

*AS* 2000