

LANG

PROCEEDINGS OF  
REPETITIVE DIVING WORKSHOP

Repetitive Diving  
Repetitive Diving  
Repetitive Diving

AMERICAN ACADEMY OF UNDERWATER SCIENCES

MARCH 18 - 19, 1991

DUKE UNIVERSITY MEDICAL CENTER  
DURHAM, NORTH CAROLINA

**PROCEEDINGS OF  
THE AMERICAN ACADEMY OF UNDERWATER SCIENCES**

# **REPETITIVE DIVING WORKSHOP**

Duke University Medical Center  
Durham, North Carolina

March 18 - 19, 1991

**MICHAEL A. LANG**

**RICHARD D. VANN**

**Editors**

American Academy of Underwater Sciences  
947 Newhall Street, Costa Mesa, California 92627 U.S.A.

An American Academy of Underwater Sciences  
Diving Safety Publication

AAUSDSP-RDW-02-92

Proceedings of the  
American Academy of Underwater Sciences  
*Repetitive Diving Workshop*

Editors

*Michael A. Lang, Smithsonian Institution*  
and  
*Richard D. Vann, Duke University*

Copyright © 1992 by  
AMERICAN ACADEMY OF UNDERWATER SCIENCES  
947 Newhall Street  
Costa Mesa, California 92627

*All Rights Reserved*

This workshop was sponsored in part by the American Academy of Underwater Sciences, the Divers Alert Network, the Diving Equipment Manufacturers Association, the F.G. Hall Hypo-Hyperbaric Lab, Duke University Medical Center, the Association of Diving Contractors and the National Oceanic and Atmospheric Administration, Grant number 40AANR100310. The U.S. Government is authorized to produce and distribute reprints for governmental purposes notwithstanding the copyright notation that appears above.

Opinions presented at the workshop and in these proceedings are those of the contributors, and do not necessarily reflect those of the American Academy of Underwater Sciences

## Contents

Preface	i
Welcoming Address	ii
About AAUS	iii
About DAN	iv
About DEMA	v
Acknowledgements	vi
<b>I. Recreational Diving</b>	
RECREATIONAL DIVING - P.B. Bennett	1
1991 RECREATIONAL MULTI-DAY DIVING OPERATIONS - D. Richardson and K. Shreeves	3
1989 VDST STATISTICS - M.H. Hahn	13
EVALUATION OF DCS INCIDENCE IN MULTI-DAY REPETITIVE DIVING FOR 77,680 SPORT DIVES - B.C. Gilliam	15
Recreational Diving Session Discussion - P.B. Bennett, Moderator	25
<b>II. <u>Andrea Doria</u> Dives Doppler Study</b>	
<u>ANDREA DORIA DIVES</u> - P.B. Bennett	30
CLINICAL EVALUATION OF REPETITIVE DEEP DIVING BY RECREATIONAL DIVERS ON THE WRECK OF THE <u>ANDREA DORIA</u> - L. Blumberg and R.A.M. Myers	31
<b>III. Scientific Diving</b>	
SCIENTIFIC DIVING - G.H. Egstrom	37
OVERVIEW OF SCIENTIFIC DIVING PROGRAMS - W.C. Sutherland and M.A. Lang	39
A DATABASE OF OPEN WATER, COMPRESSED AIR, MULTI-DAY REPETITIVE DIVES TO DEPTHS BETWEEN 100 AND 190 FSW - C.E. Fife, G. W. Pollard, G.Y. Mebane, A.E. Boso and R.D. Vann	45
Scientific Diving Session Discussion - G.H. Egstrom, Moderator	55
<b>IV. Commercial Diving</b>	
COMMERCIAL DIVING - A. Galerne	61
SHORT AND REPETITIVE DECOMPRESSIONS IN AIR DIVING PROCEDURES: THE COMMERCIAL DIVING EXPERIENCE - J.P. Imbert, X. Fructus and S. Montbarbon	63
CAL DIVE INTERNATIONAL - J. Reedy	73
SUBSEA INTERNATIONAL - G.L. Beyerstein	75
AMERICAN OILFIELD DIVERS, INC. - H.G. Mills	81
GLOBAL DIVERS AND CONTRACTORS - R.K. Merriman	85
OCEANEERING INTERNATIONAL - T. Overland	89
COMMERCIAL DIVING SERVICE, INC. - J. Hazelbaker	103
Commercial Diving Session Discussion - A. Galerne, Moderator	105
<b>V. Dive Computers</b>	
DIVE COMPUTERS AND MULTI-LEVEL, MULTI-DAY REPETITIVE DIVING - J.E. Lewis	113
ORCA INDUSTRIES' DIVE COMPUTERS AND REPETITIVE DIVING - P.A. Heinmiller	129
SUUNTO DIVE COMPUTERS - B. Oliver	131
DACOR DIVE COMPUTERS - M. Walsh	133
TEKNA COMPUTEK - R. Coley	135

REPETITIVE MULTI-DAY, MULTI-LEVEL DIVING TESTS OF THE EDGE ALGORITHM	- K.E. Huggins	137
COMPARISON OF NO-D LIMITS FOR REPETITIVE DIVES - M.H. Hahn		145
Dive Computer Session Discussion - J.E. Lewis, Moderator		151

#### VI. Dive Recorders

JOTRON DIVE RECORDER and CONSIDERATION OF SOME GENERAL ASPECTS	OF DIVE RECORDER OUTPUT - R.E. Peterson	155
SAITAMA DIVE RECORDERS AND ANALYSIS SYSTEM - Y. Gotoh		159
UNDERWATER PHYSIOLOGICAL DATA LOGGER - J. Henderson, R. Morin, A. Olszowka,	B. Laraway and S.K. Hong	169
ORCA's DELPHI DATALOGGER - P.A. Heinmiller		175
DAN ACCIDENT REPORTS - J. Dovenbarger		179
Dive Recorder Session Discussion - K.E. Huggins, Moderator		181

#### VII. Physiology, Medicine and Environment

DECOMPRESSION PHYSIOLOGY - R.D. Vann		187
DIVE PROFILES AND ADAPTATION: PRESSURE PROFILES TARGET SPECIFIC TISSUES	FOR DECOMPRESSION INJURY - C.E. Lehner	203
DECOMPRESSION-INDUCED BUBBLE FORMATION IN HUMANS AFTER	SHALLOW SATURATION DIVES - R.G. Eckenhoff	219
QUANTIFICATION OF SYMPTOMS IN DECOMPRESSION ILLNESS - R.E. Moon	and C.A. Piantadosi	227
Physiology, Medicine and Environment Session Discussion - R.D. Vann, Moderator		231

#### VIII. Data Analysis and Procedure Calculation

ASPECTS OF DIVE DATA: PRIMARY AND SECONDARY - R.W. Hamilton		237
DESIGN OF MULTI-DEPTH DECOMPRESSION TABLES USING A MODEL OF TISSUE GAS	BUBBLE DYNAMICS - M.L. Gernhardt, C.J. Lambertsen, R.G. Miller, E. Hopkin & K. Guveyian	243
QUASI-PHYSIOLOGICAL DCS INCIDENCE MODELING - W.A. Gerth, R.D. Vann	and D.G. Southerland	253
APPLICATION OF MAXIMUM LIKELIHOOD ANALYSIS TO REPETITIVE AIR DIVING	- P. Tikuisis and R.Y. Nishi	263
STATISTICALLY BASED DECOMPRESSION TABLES - G.W. Albin		269
Data Analysis and Procedure Calculation Session Discussion, R.W. Hamilton		281

#### IX. Decompression Trials

DESIGN OF DIVE TRIALS - S.S. Survanshi, P.K. Weathersby, L.D. Homer and E.D. Thalmann		287
SURFACE INTERVAL OXYGEN: RATIONALE AND STUDY DESIGN - T.A. Fawcett,	R.D. Vann and W.A. Gerth	293
DSAT DIVE TRIALS - TESTING OF THE RECREATIONAL DIVE PLANNER - R.E. Rogers		299
DESIGN OF DECOMPRESSION TRIALS - DCIEM EXPERIENCE - R.Y. Nishi		311
Decompression Trials Session Discussion, R.Y. Nishi, Moderator		321

Session summaries	325
Participant List	329
Final Program	335

## Preface

The fourth major AAUS Workshop addresses the complexities of multi-level, multi-day, repetitive diving. The information contained in these proceedings is the result of the combined efforts and knowledge of nearly sixty recognized experts drawn from a variety of fields related to diving. The discussions reflect some differences of opinion with regard to the options available to the diver performing repetitive dives. The message from these experts is, however, quite clear. There is a risk associated with multi-day, multi-level repetitive diving. A one hundred-fold decrease in the incidence of decompression illness can be obtained by limiting dives to the no-stop range and obtaining continuous training, recertification and experience.

Three years ago, with the knowledgeable assistance of Bill Hamilton, Glen Egstrom and Dick Vann, I initiated a three-tiered project that demanded three major AAUS workshops and three years of effort in an attempt to bring some preliminary results into focus. There are still many unresolved, or at least compromised, issues regarding dive computers, biomechanics of safe ascents, and multi-level, multi-day, repetitive diving. The need for further research into the fundamentals of decompression physiology is evident, as is the absolute need to acquire hard data in order to promulgate more precise guidelines with a higher level of confidence. Nevertheless, the diving communities' efforts to advance diving and its related technologies have received the benefit of the most appropriate diving expertise available on these topics, contained in these three interrelated workshop proceedings.

We are indebted to a group of dedicated professionals who gave of their time and energy to discuss their repetitive diving experiences that represent the state-of-the-art in the understanding of the complexities of this type of diving. As a result of this workshop, we have a clearer understanding of the known and the unknown that should provide guidance for our training programs and challenges for our researchers.

Michael A. Lang  
President  
American Academy of Underwater Sciences

## Welcoming Address

**Michael A. Lang, Smithsonian Institution.**

Good morning, ladies and gentlemen. Welcome to the Duke University Medical Center for the AAUS Repetitive Diving Workshop. Dick Vann and I would very much like to thank the sponsoring organizations of this Workshop which enabled us to convene our speakers here and get this information reviewed, discussed and presented in a published format so that we can continue the educational process of the diving community at large. We specifically wish to acknowledge the American Academy of Underwater Sciences (AAUS), the Divers Alert Network (DAN), the Diving Equipment Manufacturers Association (DEMA), the National Oceanic and Atmospheric Administration (NOAA) Office of Undersea Research, the F.G. Hall Hyperbaric Laboratory of Duke University, and the Association of Diving Contractors (ADC). We also would very much like to thank the workshop speakers for having prepared their presentations and their papers, as well as the discussants and participants taking part in this program.

**Richard D. Vann, Duke University Medical Center.**

I also want to thank you for coming. We really appreciate your interest and your support, particularly Andre Galerne, who put a lot of effort into getting the ADC members together here, en masse. While decompression has many very interesting and fundamental questions associated with it that scientists could study in isolation from the real world, I think it is important to remember that decompression originated from practical problems. Today's presentations and future research, we hope, will be useful to those operators who have questions concerning safety and efficiency. That is why this program was organized with a strong operational component followed by scientific presentations. We are anticipating good interaction between scientists and divers.

Let me review the goal, objectives and rationale of the workshop. Our goal is to present information which might help to understand the physiology of decompression and eventually to reduce the risks and improve the efficiency of repetitive diving. This goal will be pursued through the following objectives:

- To understand the operational and environmental problems which face the various diving communities and to encourage cooperation and coordinated effort between these communities for their mutual benefit;
- To assess and interpret the operational experience as it might relate to the underlying physiology and,
- To discuss methods for analyzing decompression data, computing decompression procedures and conducting decompression trials.

The state of the art of repetitive diving as defined here includes multi-level, multi-day diving, compressed air work and surface decompression. These techniques are to be evaluated from collective operational experience. Through discussions of this information, hypotheses concerning the mechanisms of decompression and decompression sickness will be formulated. These hypotheses might eventually be tested by experimental trials and statistical analysis of decompression databases. Databases, analytical methods and the design and conduct of decompression trials will be presented to establish a quantitative foundation for the development of computer algorithms and repetitive decompression procedures which are as efficient as acceptable risk will allow. An exchange of ideas will be encouraged by providing ample time for both formal and informal discussion. We will review the comments you made, so if you have a brilliant insight after you leave here or if you discovered that what you have done for the last 30 years is wrong, we might change it!

## **About AAUS**

The American Academy of Underwater Sciences (AAUS) is a non-profit, self-regulating body dedicated to the establishment and maintenance of standards of practice for scientific diving. The AAUS is concerned with diving safety, state-of-the-art diving techniques, methodologies, and research diving expeditions. The Academy's goals are to promote the safety and welfare of its members who engage in underwater sciences. These goals include:

- To provide a national forum for the exchange of information in scientific diving;
- To advance the science and practice of scientific diving;
- To collect, review and distribute exposure, incident and accident statistics related to scientific diving;
- To promote just and uniform legislation relating to scientific diving;
- To facilitate the exchange of information on scientific diving practices among members, and;
- To engage in any or all activities which are in the general interest of the scientific diving community.

Organized in 1977 and incorporated in 1983, the AAUS is governed by a Board of Directors. An Advisory Board of past Board of Directors members provides continuity and a core of expertise to the Academy. Individual membership in AAUS is granted at the Member, Associate Member, and Student Member categories. Organizational membership is open to organizations currently engaged in scientific diving activities. Maintenance of membership is dependent on a continued commitment to the purposes and goals of the Academy, compliance with the reporting requirements and payment of current fees and dues.

- For the diving scientist, AAUS provides a forum to share information on diving research, methodologies and funding;
- For the diving officer, AAUS provides an information base of the latest standards of practice for training, equipment, diving procedures and managerial and regulatory experience, and;
- For the student, AAUS provides exposure to individuals, agencies and organizations with on-going programs in undersea research.

Scientific diving means diving performed solely as a necessary part of a scientific activity by employees whose sole purpose for diving is to perform scientific research tasks. Scientific diving does not include tasks associated with commercial diving such as: rigging heavy objects underwater, inspection of pipelines, construction, demolition, cutting or welding, or the use of explosives.

Scientific diving programs allow research diving teams to operate under the exemption from OSHA commercial diving regulations. This reduces the possibility of an OSHA fine and some concern regarding civil liability. Civil suits examine whether the "standards of practice of the community" have been met. Diving programs which conform to AAUS standards reflect the standard of practice of the scientific diving community and allow divers from different institutions to perform underwater research together. This reciprocity between programs is the product of years of experience, trust and cooperation between underwater scientists.



## About DAN

In 1980, an increasing need for a diver assistance service resulted in the initiation of the Divers Alert Network (DAN). Its mission was to enhance diving safety for recreational scuba divers by:

1. Providing assistance to injured divers, including treatment referral;
2. Collecting statistics on diving casualties to prevent future fatalities and injuries, and;
3. Providing information to physicians and the general public regarding health issues pertaining to scuba diving.

The Divers Alert Network has advanced along with the increasingly sophisticated dive equipment and multitude of divers' destinations. Wherever divers go throughout the world, they can call a single number for assistance or information.

As the largest diving safety organization in the world, DAN lends its expertise and structural framework to other assistance agencies. In 1991, DAN hosted the first International Workshop for Diving Assistance. Additionally, a worldwide accident insurance program is being investigated. This international event has provided the basis for a global diving safety network.

DAN has been accomplishing its safety mission by providing a wide variety of medical and advisory services to recreational divers and physicians:

- **24 - hour Medical Emergency Hotline (919) 684 - 8111** to provide injured divers with medical consultations and referrals. DAN receives over 1,000 emergency calls each year.
- **Non-Emergency Advisory Line (919) 684 - 2948** to provide answers for commonly asked questions about scuba diving medicine and safety. The DAN medical information line now handles over 8,000 calls each year.
- **Alert Diver** - the official newsletter of Divers Alert Network. Alert Diver is distributed free to medical professionals, government and law enforcement agencies, and is the industry leader in providing the latest in diving medical safety information.
- **Diving Safety Courses** - These seminars are CME and CEU accredited and offer continuing education hours for medical professionals. DAN's Oxygen First Aid in Dive Accidents program is a new and exciting course to teach the basics of administering oxygen to injured divers.
- **Dive Accident Insurance** - DAN pioneered diving injury insurance for recreational divers. Diving injuries such as decompression sickness, air embolism, and pulmonary barotrauma are covered. Also included under this plan are emergency air evacuation and all in-water injuries.
- **Annual Report on Scuba Diving Accidents** - DAN collects and analyzes recreational diving injuries in an annual report. Trends in injuries, types of injuries, and effectiveness of treatment are reviewed each year. Identification of specific causes of diving injuries and common denominators is very useful in educating the diving public in the prevention of accidents.
- **Report on Diving Fatalities** - The latest DAN service to the diving public is the collection and analysis of recreational scuba diving fatalities. Mortality studies are valuable in identifying specific causes of death, such as experience level, activity, and health. Through the publication of this report, DAN hopes to increase diver awareness and ultimately attempt to reduce diving deaths.

## **About DEMA**

The Diving Equipment Manufacturers Association (DEMA) is a not-for-profit corporation. By education of the public, DEMA's goals include:

- To promote, foster and advance the common business interests of its members as manufacturers of diving equipment;
- To educate the public in the use of diving equipment in order to promote public safety and welfare;
- To improve the trade practices of the industry, and to develop fair practices and methods;
- To improve conditions within the industry, promote a better understanding among those engaged therein, and collect and disseminate data relative to the industry, and;
- To encourage minimum standards among the members of the association in order to improve the quality of the diving equipment used by the public.

Originally incorporated in Illinois in 1963, DEMA reincorporated in 1976 as a California non-profit trade association to obtain the legal right to operate a trade show. DEMA is governed by a Board of Directors and managed by an Executive Director. DEMA's membership exists of categories for regular and associate members

DEMA initiated its annual trade shows in 1977. In 1978, DEMA committed its resources to retailer education by providing business management, educational and advertising seminars. In 1979, the "Discover Diving" campaign was launched to support diving retailers nationwide. In 1980, the Harvey Research Organization was commissioned to study market-related attitudes of divers, retailers and instructors. The Graduated Experience Method (GEM) Program was funded by DEMA in 1981, the findings of which assisted the scuba training agencies in producing a variety of "graduated" and "modular" programs. This resulted in recreational diving becoming readily available to families and busy professionals. In 1983, DEMA released its first in a series of promotional films and press kits in response to retailers requests. "Store Owners' Advertising and Promotion" and "Meet the Press" DEMA media kits were released at subsequent trade shows.

In past years, DEMA has supported engineering studies, diving safety research projects at URI and UCLA, the DEMA census, DAN, Handicapped Scuba Association, and critical legislative affairs efforts. DEMA's goals for the 1990's include:

- To develop and implement advertising and promotion programs to reach out and capture greater diversity and numbers of consumers;
- To continue to shift positioning from diving as a "sport", to diving as a "recreation";
- To create an umbrella industry organization to foster cooperation, to pool resources, promote diving, and collect/share statistical and informational data;
- To develop a program of diver retention, and;
- To protect, preserve and enrich diving's most important resource, the aquatic environment, through a new subsidiary, the Ocean Futures Foundation.

**Acknowledgments**  
**Michael A. Lang**  
**Workshop Co-Chair**

First, I need to thank the following people for providing the support, input and the funds to assist in the production of this Workshop: Chuck Mitchell of AAUS, Peter Bennett of DAN, Ralph Osterhout and Dick Bonin of DEMA, David Duane of NOAA, Claude Piantadosi of the F.G. Hall Hypo-Hyperbaric Laboratory and André Galerne of the Association of Diving Contractors (ADC).

Special thanks to the session moderators (Peter Bennett, Glen Egstrom, André Galerne and Gary Beyerstein, John Lewis, Karl Huggins, Dick Vann, Bill Hamilton and Ron Nishi) for keeping their speakers on time and for the final summary session review, especially Dick, Bill and Ron for the excellent wrap-up with little time to prepare.

I also thank the speakers of the recreational, commercial and scientific diving groups. We really appreciated the interaction, especially with the commercial people, since we have not had a joint workshop opportunity like this before; it was very productive. Our speakers from the hyperbaric, medical and research communities did an outstanding job. Special thanks to our international colleagues - Jean-Pierre Imbert, Yoshiyuki Gotoh, Max Hahn, Peter Tikuisis and Ron Nishi - who traveled a long way to share their knowledge. The dive computer and dive recorder manufacturers' efforts are appreciated as we continue to enjoy this longstanding, productive, working relationship.

Our special thanks to Edna Pollock for her recording efforts and to Cindi Easterling for keeping us organized.

Final layout and production of these proceedings was supported by the Smithsonian Institution Scientific Diving Program, Office of the Assistant Secretary for Research.

I especially thank Dick Vann, my Co-Chair, who was the driving force in refining the repetitive diving issues to our speakers. Without appropriate speakers, there is no productive workshop program, so that credit goes mostly to Dick. Without participants, there is no discussion, nor applause, so I thank you all very much for participating.

On a final note, compiling and editing these proceedings was a monumental, non-salaried effort. I gratefully thank Maria, Michelle, Nicole and Sergio Lang for their patience, support and understanding for the many weekend and evening hours spent away from them, locked up in the office. The results of this workshop are however, satisfyingly evident and should contribute to safer diving for all.

## Session I - Recreational Diving

Peter B. Bennett, Moderator

Repetitive diving is of significant importance to recreational diving. There are more divers doing this kind of diving than any other modality. And yet, as we know, it is not working as well as we would hope. Recreational divers are doing anywhere from three to five dives per day, anywhere from four, five, six, seven days a week, or even more than that, on live-boards.

This is certainly repetitive diving with a vengeance. The 1989 data shows 653 accidents that the Divers Alert Network knows about, of which we get 391 cases back. There were 553 cases in 1988. In fact, the numbers are increasing. This may well be because the numbers of divers are increasing. There are more divers being trained by the training agencies. International analysis of how many divers are around proposes a figure of about 3.5 million worldwide. The American training agencies tell you there are 3.5 million in the United States. I personally think there are about two million divers in the United States and worldwide somewhere between three and four.

If we examine single day diving and repetitive dives on a single day, we find that neurological cases, which we feel is the result of repetitive diving, is a predominant amount at 57 and 67 per cent. There is very little DCS Type I which we were seeing in the ordinary single day dives, for which tables were primarily developed by the U.S. Navy. In many ways, the diving that is being done today is not typical of what the U.S. Navy predicted. Divers are going deeper more frequently, diving more often per day and more days in the week, profiles for which the tables were never designed. So, we shouldn't be surprised perhaps that we are getting diving accidents.

If we examine multiple day diving (diving several days a week), there is the same heavy distribution into neurological decompression sickness (Type II). If we look at the risk profile, we find that most of the divers were diving within tables, as far as they knew them and as far as the tables meant anything. They were diving greater than 80 fsw, no decompression, and doing repetitive dives, square dives, or multi-day dives. The evidence is that the potential risk factors are leaning heavily into the multi-day, square dives, repetitive dives, no-D, greater than 80 foot and within the tables. This tells us that when you perform repetitive dives, even the no-decompression mode when you think you should be okay and certainly well within the tables, you ought to be safe - you certainly are not.

Dive computer user profiles are similar, certainly deeper than 80 foot and we can tell you that the computer divers are diving a lot deeper. Unfortunately, they believe the computers are better than tables, do not realize that the algorithms are much the same and, in fact, are pushing depth. They are certainly doing repetitive dives because they're designed for multi-level diving. The multi-level, multi-day repetitive dives are the emphasis of the heavier areas of diving accidents outside of the tables.

That is one factor, but there is more to it than that. If that was only the situation, I do not think we need be that worried. We would have to do some more mathematics and come up with better tables, but it is much more complex than that because within the population of divers we have, taking live-board diving that are diving five or seven dives a day as an example, why do we not get many accidents on liveboards. They are diving very heavy compared to the diving from the shore doing three or four dives a day. I do not know what that means. We may learn something during the course of this meeting. Is there adaptation with repetitive diving or not? Maybe there is an adaptation after a certain number of dives. So, adaptation, the role of multi-day and multi-level diving and the live-board problem is something I hope we get to address.

How many times a day should you dive on the tables we have got? Can we provide an answer to the recreational diving industry? Can we help to prevent some of the diving accidents we are seeing? Some of the trials that have been going on suggested that three or four dives a day was enough if you

are going to go six days a week. Now, is that correct or not? These are practical problems for recreational divers which the industry really needs to have answers to and it's the one big area, I think around the world, which is growing rapidly and which is doing the kind of diving for which the tables were never designed and yet they do not realize it. The lawyers perhaps realize it when they come to court, when the poor instructor has to face a court case, but we're not really helping them. I am very glad to see and DAN was very glad to support this particular Workshop because it is an area right in the heart of recreational diving for which there are no answers at the moment. We can see if the body of opinion here will help us solve the problem.

## 1991 RECREATIONAL MULTI-DAY DIVING OPERATIONS SURVEY

*Drew Richardson*  
*Karl Shreeves*  
International PADI, Inc.  
1251 East Dyer Road No. 100  
Santa Ana, CALIFORNIA 92705 U.S.A.

*A survey of 18 dive resort operations and 9 liveaboard dive operations was made to determine repetitive and multi-day diving practices actually in existence today. Seven training organizations were also surveyed. In this study, which represents an estimated 1.6 million man-dives annually, typical numbers of dives per day, consecutive days diving, surface intervals, depth distribution and safety practices of recreational divers are identified and recorded.*

### Introduction

Certification statistics kept by International PADI Inc., a recreational scuba training organization, show that recreational diving is on the rise. In 1980, the PADI organization issued 107,404 certifications, in 1985, 260,319 certifications, in 1989, 397,728 certifications and in 1990, 450,883 certifications. As recreational diving has grown more popular, the number of dive resorts and liveaboard dive boats has increased to meet this consumer demand.

Both dive resorts and liveaboards offer opportunities for repetitive diving over consecutive days. At the same time, it must be recognized that little test data exists for decompression protocols beyond three or four repetitive dives, or for several consecutive days of diving. While it is intuitively clear from anecdotal reports that recreational repetitive multi-day diving is beginning to push beyond the body of tested decompression practices, what is unclear is to what extent. For example, anecdotal reports of five or more dives daily for six consecutive days on liveaboard boats are common. While there is no proven risk from this type exposure, this type of diving is untested. This study was initiated by the authors, under the direction of Richard D. Vann, Ph.D., Director of Applied Research at F.G. Hall Laboratory, Duke University Medical Center, to uncover the range of common, intensive, recreational multi-day repetitive diving activities.

### Methods and Materials

The 1991 DEMA (Diving Equipment Manufacturers Association) Show in Las Vegas, Nevada, offered an ideal opportunity to conduct the survey. The annual DEMA show brings together, among other dive industry members, global representatives of dive resorts and liveaboard dive boats. Using a confidential survey form (see Appendix), a personal interview was conducted with resorts and liveaboard operations at 1991 DEMA Show. The interviewer asked probing questions on procedures and sought to capture reports on standard operations and decompression procedures. Dr. Vann assisted this questioning by a priori reviewing the survey form.

Eighteen dive resorts, nine liveaboard dive boats and seven training organizations were interviewed. It is significant to note that some operations operate more than one liveaboard boat or resort, so the number of such boats and resorts represented by this survey exceeds 27. An effort was made

to give the survey a worldwide distribution, yet the Caribbean, with its large concentration of such operations, is overrepresented.

A guarantee of confidentiality was given to interviewees to encourage accurate reporting free of competitive concerns or possible complications with their respective training organizations. All interviewees worked first-hand with diving operations. Second-hand reports of diving practices were excluded.

Many interviewees answered questions with ranges rather than specific numbers; in many cases, it was necessary to use a single number from such ranges to derive data. In these instances, the lowest number in the range was used. An example of this is the estimation of 1.6 million man-dives per year being represented by this survey. This was the total of all dives at all operations derived as follows in this example: For an operation reporting 6000-7000 divers per year, 7 to 10 days diving per diver per stay, 3 to 6 dives per day =  $6000 \times 7 \times 3 = 126,000$  man-dives per year.

Specific comments regarding the data accompany some of the following tables.

### Results

Table 1. Distribution of Operations.

<u>Location</u>	<u>Resorts</u>	<u>Liveboards</u>
Worldwide -- multiple operations	2	2
Australia		1
Bahamas	2	2
Bonaire	1	
Cayman	4	
Cozumel	2	
Fiji	1	
Florida	1	
Hawaii	1	
Honduras	1	
Micronesia	2	1
Red Sea		1
St. Lucia	1	
St. Maarten		1
Sea of Cortez		1

Table 2. Approximate Number of Divers Per Year.

<u>Number of Divers/Year</u>	<u>Resorts</u>	<u>Liveboards</u>
1000 or less	1	4
1001 - 5000	9	2
5001 - 10,000	2	3
10,001 - 15,000	2	
15,001 - 20,000	1	
20,001 - 25,000		
25,001+	1	
No answer	2	

**Table 3. Days Spent at Operation / Actual Days Diving.**

<u>Ratios</u>	<u>Resorts</u>	<u>Liveboards</u>	<u>Both Groups</u>
3/2	1 (5.5%)	0	1 (3.7%)
3/3	1 (5.5%)	0	1 (3.7%)
4/3	1 (5.5%)	1 (11%)	2 (7.4%)
4/4	2 (11%)	0	2 (7.4%)
5/4	2 (11%)	0	2 (7.4%)
6/5	0	1 (11%)	1 (3.7%)
7/5	2 (11%)	3 (33%)	5 (18.5%)
7/6	5 (28%)	3 (33%)	8 (29.6%)
7/7	0	1 (11%)	1 (3.7%)
8/6	1 (5.5%)	0	1 (3.7%)
Insufficient information	3 (17%)	0	3 (11%)

The survey sought to compare the number of days spent at a resort or on a liveboard with the number of days on which dives were actually made. The following "number of days at operation"/"number of actual dive days" ratios were reported:

The following averages came out of the data. "Of operations surveyed" is the average number of days reported by the operations. "Of diver per season" is the average of all the divers at all the operations staying the number of days reported by each operation. In both cases, the lowest numbers were used when ranges were given.

**Days Spent with Operation average**

	<u>Resorts</u>	<u>Liveboards</u>	<u>Both Groups</u>
Of operations surveyed	5.66 days	6.55 days	6.00 days
Of diver per season	6.39 days	6.64 days	6.44 days

**Days Diving average**

	<u>Resorts</u>	<u>Liveboards</u>	<u>Both Groups</u>
Of operations surveyed	4.66 days	5.33 days	4.91 days
Of diver per season	4.9 days	5.57 days	5.00 days

**Table 4. Number of Dives Per Day.**

<u>Number Dives/Day</u>	<u>Resorts</u>	<u>Liveboards</u>	<u>Both Groups</u>
2 or less	13 (72.2%)	1 (11%)	14 (52%)
3	5 (27.8%)	1 (11%)	6 (22%)
4	0	5 (55.5%)	5 (19%)
5	0	2 (22.5%)	2 (7%)

**Dives per day average**

	<u>Resorts</u>	<u>Liveboards</u>	<u>Both Groups</u>
Of operations	2.24	3.83	2.77
Of diver per season*	1.95	3.42	2.23
*16 resorts reporting			

Note: As noted, these numbers are based on lowest reported by each operation. Five (55.5%) liveboards reported dives-per-day routinely exceeding 5.



**Table 5. Typical Dive Depth Distribution.**

<u>Range</u>	<u>Percent of Dives</u>		
	<u>Resorts</u>	<u>Liveaboards</u>	<u>Both Groups</u>
0-30 ft	18%	6%	16%
31-60 ft	31%	54.6%	35%
61-90 ft	40%	24%	37.4%
91-130 ft	10%	14.8%	11%
131+ ft	1%	0.6%	0.6%

Note: Only 5 liveaboards and 12 resorts operations could estimate general dive depth distribution. This distribution is adjusted based on number of man-dives (based on lowest in ranges) per season at each reporting operation.

**Table 6. Typical Surface Interval Duration.**

<u>Surface Interval</u>	<u>Resorts</u>	<u>Liveaboards</u>	<u>Both Groups</u>
0 to 60 minutes	12 (66.6%)	2 (28.6%)	14 (56%)
61 to 120 minutes	2 (11%)	1 (14.3%)	3 (12%)
121 to 180 minutes	4 (22.4%)	3 (42.8%)	7 (28%)
181 to 240 minutes	0	0	0
241 to 300 minutes	0	1 (14.3%)	1 (4%)

Note: 18 resorts and 7 liveaboards reported. In general, resorts were able to give more accurate estimates of surface intervals. Liveaboards reported greater variation and tended to be more vague.

**Table 7. Decompression Sickness Reported.**

<u>Cases Per Year</u>	<u>Resorts</u>	<u>Liveaboards</u>	<u>Both Groups</u>
less than 1	15 (83%)	5 (56%)	20 (74%)
1	1 (6%)	1 (11%)	2 (7.4%)
2	2 (11%)	2 (22%)	4 (14.8%)
3	0	0	0
4	0	0	0
5	0	1 (11%)	1 (3.8%)

Note: Reports on DCS from both resorts and liveaboards tended to be vague and guarded. No relationship between days dived or number of dives per day and DCS cases reported was found.

The following "worst case" DCS incident rates were derived based on "less than per 1 year" = 1, and the fewest estimated man-dives per year.

Resorts - 1 case in 63,882 dives (.0016%)  
 Liveaboards - 1 case in 34,300 dives (.0029%)  
 Group - 1 case in 49,996 dives (.002%)

**Table 8. Percent of Divers Using Dive Computers.**

	<u>Resorts</u>	<u>Liveaboards</u>	<u>Both Groups</u>
Divers using computers	23%	58%	29%

Note: Based on averages of percentage estimations by operations and their divers-per-season.

**Table 9. Relationship of Dive Computer Use and Multi-level Diving.**

	<u>Resorts</u>	<u>Liveboards</u>	<u>Both Groups</u>
In operations permitting multi-level diving.*	39.5%	55%	46.8%
Range	5%-90%	5%-95%	5%-95%
In operations not permitting multi-level diving.*	19.1%	NA	19.1%
Range	0%-50%	NA	0%-50%

Note: Average reported percentages of computer-using divers.

\*Multi-level is defined as permitting profiles that extend bottom time beyond the NDL of the deepest depth by crediting for ascent to a shallower depth. All liveboards said they permit multi-level diving. One resort said it permits neither multi-level diving nor computer use. Other resorts that do not permit multi-level diving said they permit divers to use computers, but only as time/depth gauges.

**Table 10. Standard Operational Practices**

	<u>Resorts</u>	<u>Liveboards</u>	<u>Both Groups</u>
Multi-day skip - Yes	3 (17%)	2 (22%)	5 (18.5%)
Multi-day skip - No	11 (61%)	7 (78%)	18 (66.7%)
Multi-day skip -- N/A*	4 (22%)		4 (14.8%)

\*Four resort operations reported 3 or fewer days of continuous diving. Multi-day skip was considered "standard" if an operation requires it, or if most divers at an operation routinely take a day off during their stay.

	<u>Resorts</u>	<u>Liveboards</u>	<u>Both Groups</u>
Decomp diving - Yes	2 (11%)	3 (33.3%)	5 (18.5%)
Decomp diving - No	16 (89%)	6 (66.7%)	22 (81.5%)
Safety stop required	12 (66.7%)	7 (78%)	19 (70%)
Safety stop not required	6 (33.3%)	2 (22%)	8 (30%)

Note: Every operation that did not require a safety stop said that it strongly recommends safety stops.

### Training Organizations

Seven training organizations, including PADI, were surveyed as to whether their training standards affect multi-day, repetitive diving. There was virtually no difference in any of the organizations:

- Maximum of 2 training dives per day at entry-level.
- No restrictions on non-training dives after certification.
- All advise conservatism when making multiple repetitive dives over multiple days, but no specific guidelines are given.

PADI's Standards, as presented in the PADI Instructor Manual, give an example of how training organizations address multi-day, repetitive diving: "No more than two open-water scuba training dives are to be conducted in a single day for any individual student (the only exception is the Advanced Open Water Diver course, which allows a night dive to be conducted following two daylight dives)."

The PADI Open Water Diver Manual advises: "Since little is presently known about the physiological effects of multiple dives over multiple days, you are wise to make fewer dives and limit your exposure toward the end of a multi-day dive series."

In *The Undersea Journal*, PADI's instructor journal, PADI members were advised: "DAN suggests that divers engage in no more than three or four consecutive multi-dive days. For example, on extended trips during which the diver is making more than two dives per day, he should refrain from diving every third or fourth day."

### Discussion

From a mathematical point of view, the number of surveys in this project makes a high statistical confidence level difficult. Nonetheless, this does not mean the information is inaccurate and the data strongly suggest that some diving practices are prevalent. If these practices exist to a greater or lesser extent than found in this survey, this survey at least reveals a need for closer examination.

#### Extent of Multi-Day Diving

There is no question that multi-day repetitive diving is widespread. The survey showed that the "typical" diver dives about five days during a six-and-a-half day stay at a resort or on a liveaboard. Apparently, taking a day off during a multi-day dive series (multi-day skip), while not uncommon, is not the prevalent practice at resorts or liveaboards. [An aside: One resort operation that caters to approx. 12,000 divers annually at three resorts said that multi-day skip has become less common since the release of the new flying-after-diving recommendations, which make it difficult to dive on the last day of the trip.]

#### Extent of Repetitive Diving

While the number of days dived were similar for resorts and liveaboards, there is a tendency to make more dives per day on a liveaboard than when at a resort. The "typical" diver makes 1.95 dives daily at a resort, compared to 3.42 on a liveaboard (about 75% more dives per day). Liveaboard reports reaching 5-6 dives daily were not uncommon, with as high as 10 dives in a day being reported.

#### Surface Intervals

Interestingly, resorts showed shorter surface intervals. Apparently, the common resort two-tank morning or afternoon resort schedule keeps surface intervals at dive resorts short, while liveaboards, which do not have tight schedules to keep, can afford a more leisurely pace between dives. This is supported by the reports: resorts gave fairly accurate specific intervals, which is consistent with running a regular schedule, whereas liveaboards tended to be more vague and cited little regularity to surface intervals.

#### Typical Profile

It was hoped that a "typical day's dive profile" would be found by this survey. Instead, it was found that there is no such thing across the board. Liveaboard boats had difficulty citing "typical" profiles, so it is impossible to extrapolate a "typical" liveaboard profile, other than diving deep in the mornings and shallower as the day progresses. Several resorts gave their daily profiles, making a rough "typical" resort profile:

- First dive: 60 to 100 feet deep for 5 minutes less than the NDL;
- Surface interval: 30 min. to 1 hour;
- Second dive: 60 feet or shallower for 35 to 45 minutes.

### **Dive Computer Use**

There is a significant number of divers using dive computers, and most operations said the number is growing. The least computer use was found among resorts that do not allow multi-level profiles and among resorts and liveboards in predominantly shallow (majority of diving above 30 feet) regions. In the latter instance, it can be speculated that because of almost unlimited dive time permitted by tables in the shallows, divers do not perceive a need for the additional time afforded by a computer. The greatest dive computer use was reported among liveboards. It can be speculated that the lack of tight schedules permits a liveboard to grant divers nearly as much dive time as they want, making a dive computer especially useful. One liveboard that specializes in deep water wrecks reported that without a dive computer, a diver misses most of the dives. Not surprisingly, this operation reported that 95%+ of its customers use computers.

### **Decompression Diving**

Although decompression diving is generally considered beyond the parameters of recreational diving, five operations reported that decompression diving was permitted. This is a surprisingly large portion of the group (18.5%) that could be an anomaly caused by the small size of the survey, or, on the other hand, could indicate that decompression diving among recreational divers is more common than previously suspected. All but one of the operations that permit decompression diving said they have strict guidelines for decompression dive supervision and minimum experience and/or training levels for participants.

### **Restrictions**

The survey found that while virtually all resorts enforce guidelines for diving, the degree of restriction varies considerably. Some resorts, in particular, specified the exact dive profile, including depths, bottom times and surface intervals. Other operations stipulated broader rules, such as "Do not exceed the no decompression limits" and other safe diving practices, leaving the diver to use his table/computer to the best advantage within the guidelines. No operation reported widespread difficulties in getting divers to stay within the limits they set. Operations with the least restrictions tended to show more dives per day and more computer use, suggesting that many divers will take advantage of more dive time if it's available. No relationship was found between DCS cases reported and the degree of diving restrictions reported by operations. For example, the operation reporting the highest DCS incidence (5 cases per year average) had a restriction of only two dives permitted per day, and reported that multi-day skip was standard procedure. Another operation that permitted decompression dives, dives below 130 feet, and typically offered five dives a day for six days continuously reported only two cases of DCS in seven years.

### **What was not said**

All operations were asked if they specified particular tables, computers or had any other special procedures or considerations that involved dive profiles and DCS avoidance. The DSAT Recreational Dive Planner and the USN tables were mentioned several times, and Bühlmann tables mentioned once, though no one "required" the use of any particular table, except as in training as specified by training organization standards. Some resorts avoided the issue by dictating maximum dive depths and times. No make or model of computer was named in any context, neither as particularly favored nor as being unacceptable. Virtually every operation required or highly recommended safety stops. No other stipulation regarding ascents was made, though it can be inferred that all operations expected divers to stay within the ascent rates specified by their tables or computers. There was no mention of nitrox, oxygen decompression or other mixed gases associated with professional/technical diving.

### **Conclusion**

DAN diving accident statistics have shown that more DCS accidents occur following multi-day diving, but this may simply reflect the growing number of divers making multi-day repetitive dives

rather than any particular risk of DCS caused by current recreational multi-day diving procedures. Without information on the numbers of dives made single-day versus multi-day, it is impossible to ascertain statistically what role, if any, multi-day repetitive diving plays in DCS risk.

The survey found that multi-day repetitive diving is widespread and common among recreational divers, and that much of it involves more than three dives a day, with five and six dives daily not uncommon. Despite possible concerns raised by accident reports, the survey found no particular evidence of unusual risk from multi-day, repetitive diving as it is currently practiced within the recreational community. This survey found a somewhat higher DCS-per-dive rate for liveboards than resorts, but a) the small survey size plus using "less-than-1-case-per-year = 1-case-per-year" in determining DCS figures makes it hard to have high confidence in their exactness, and b) even the higher rate indicates less than 3 cases in 100,000 dives.

#### References

DAN 1987, 1988, Diving Accident Report. Divers Alert Network, Durham, NC.

PADI Instructor Manual, International PADI, Inc. 1987, 1988, 1989, 1990

PADI Open Water Diver Manual, International PADI, Inc., 1988, 1989, 1990

Richardson, D., "How Much Diving is Too Much?" Undersea Journal second quarter 1990.

**Appendix I. Survey Form**

All information confidential.

Operation Type:       Liveboard       Resort       Charter

Operation Name: \_\_\_\_\_

Location: \_\_\_\_\_

Operating Season: \_\_\_\_\_ through \_\_\_\_\_

Approx # divers per season: \_\_\_\_\_ Approx. % using computers: \_\_\_\_\_

Approx. # DCS incidents/year: \_\_\_\_\_

Per Typical Diver

Average trip/stay length: \_\_\_\_\_ Days diving per trip/stay: \_\_\_\_\_

Number of dives per day: \_\_\_\_\_

Depths - Approx. %    0 - 30 ft. \_\_\_\_\_ 31 - 60 \_\_\_\_\_ 61 - 90 \_\_\_\_\_ 91 - 130 \_\_\_\_\_

Deeper than 130 ft.: \_\_\_\_\_ Normal surface interval: \_\_\_\_\_

Typical Profile

Standard Practices

Multiday skip? Yes  No  Decompression diving permitted? Yes  No

Safety stop required? Yes  No  Multilevel permitted Yes  No

Tables used: \_\_\_\_\_

Special diving restrictions or problems. If decompression diving is permitted, please explain restrictions, if any.

Appendix II. Listings from Survey

<u>Operation</u>	<u>Divers/yr</u>	<u>tripday</u>	<u>divday</u>	<u># div/day</u>	<u>DCS/yr</u>	<u>mdskp</u>
<b>Liveboards</b>						
TF	1400	7	6-6.5	5	2 in 7 yrs	no
AF	7-8000	7	6	4-5	< 1	no
CE	550	7	6	3	1 in 3.5 yrs	no
BC	1000	7	5	4	< 1	yes
MB	3000	4-9	3-8	4	1-2	no
SD	7000	7	5	2	5	yes
SF	600	6-7	5-6	5-6	2	no
BE	300	7	5	4-5	.25	no
SS	6000	7-10	7-10	3.5-6	1	no
<b>Resorts</b>						
SH	10,000	7	6	2-3	2	no
DF	10,000	4	4	2-4	< 1	no
BS	15-20,000	7	6	2	< 1	no
CM	25-30,000	7	5	1.5	< 1	yes
CL	1500	7	6	2+	< 1	no
BD	5000	3	2	2	< 1	yes
AC	14,000	7	6	2	< 1	yes
WC	1100	5	4	3	< 1	no
MB	1000	4	4	2	< 1	no
LC	2800	5	4	3	< 1	no
CD	3360	8	6	2.8	< 1	no
PD	12,000	7	5	2	1	no
FC	5000		3	2	< 1	
LD	3000		3	2	< 1	
PR	1700		3.6	2	< 1	
DP	3500		3-4	2	3 in 7 yrs	
AK		7	6	3	2	no
GD		3	3	3	< 1	no

## 1989 VDST STATISTICS

*Max H. Hahn*  
Abt. f. Immunbiologie  
Med. Einr. d. Heinrich-Heine-Universität  
Moorenstr 5  
D-4000 Düsseldorf 1, GERMANY

*Evaluation of questionnaire forms, sent back from members and clubs of VDST (German Sport Divers Association) shows an average of 17.4 dives per member in 1989. 25.3% of these were second dives/day, 2.6% were third or higher dives of per day. Tables and DCs at least should yield 'equal risk' schedules for the first two dives of a day.*

### Introduction

Efforts to better understand and consequently improve safety level of decompression procedures for repetitive dives is justified, if these are sufficiently frequent. Figures from a central European country with comparatively short coastline but good access to seashores are given. Other countries with different geographical (and economic) conditions may yield somewhat different figures. But there are reasons to assume, that the frequency of repetitive dives is approximately equal in other countries.

### Data Acquisition

From December 1990 to January 1991 questionnaire forms were distributed to all club members asking for number of dives in 1989 (from logbooks) in fresh water, in sea water, in depths of 0-15m, 15m-25m, over 25m; number of days with 2 dives, with 3 or more dives; qualification level in 1989: CMAS (Confédération Mondiale des Activités Subaquatiques) diver 1 star, 2 star, 3 star, 4 star, pool trainer, diving instructor.

The club management committees were asked to add the numbers on the forms sent back by their members and report the total number of enlisted members male, female. The number of pool training hours/week and the average number of participants were also asked for. Until March 10, almost complete reports from 35 clubs, with a total membership of 2015 were received.

### Results

The average number of VDST members was 30,817 in 1989. Judging from the above mentioned reports, an average of 17.4 dives/member was made. 75.1% of the members were male.

As 10 cases of DCS were reported to the insurance in 1989, an incidence of 19 reported cases per million dives is found. The recently collected data for 1990 are almost identical. Due to the small absolute number of DCS cases, confidence limits are rather wide [Fig 1]. In general, the reported number of DCS cases/member kept constant in the past years. Due to the fast growing diving community [Fig. 2], the absolute numbers naturally increased. The distribution of the dives over fresh/sea water, depths and first, second and third+ dives is shown on Fig 3: Fresh and sea water dives are almost equal in number, the depth ranges (0-50 fsw, 50-78 fsw, over 78 fsw) contain roughly one third of the dives each.



Nearly 3/4 of all dives are first dives of a day, almost 1/4 are second dives while third and higher dives only amount 2.6%.

Experience makes it very probable, that the majority of 2-dive-days represent diving with recreational diving resorts in the Mediterranean and Maldivian seas. The 3+-dive-days may be mainly resulting from instructional and examination dives of honorary VDST diving instructors.

68% of the members covered by the reports have a certificate. This is obviously the active fraction of the paying club members. Of these certificates, 41.2% are CMAS diver \* level, 39.4% \*\*, 10.4% \*\*\* and 5.5% \*\*\*\*. 5.6% have a licence as pool trainer (requiring CMAS diver\*\*\* certificate and a 120 hour licence course). 3.4% are VDST-CMAS \*, \*\* or \*\*\* diving instructors.

The relative high fraction of \*\*-divers (compared to \*-divers) reflects the demands arising from the large percentage of dives made in cold, dark and muddy fresh waters, *i.e.* irrigation dams, gravel pits and quarries. A few years ago, the German 'bronze diving badge', originally meant as equivalent to 'open water diver', was redefined to be \*\*-diver equivalent by CMAS.

### Conclusion

Approximately one half of all diving days comprise two dives. Future tables and dive computers should yield 'equal risk' schedules for at least the second dive of what is to be considered as 'repetitive diving'.

## **EVALUATION OF DECOMPRESSION SICKNESS INCIDENCE IN MULTI-DAY REPETITIVE DIVING FOR 77,680 SPORT DIVES**

*Bret C. Gilliam*  
OCEAN TECH  
3098 Mere Point Road  
Brunswick, MAINE 04011 U.S.A.

### **Introduction**

In June of 1988, OCEAN QUEST INTERNATIONAL wished to enter the sport diving market with a cruise ship accommodating 160 recreational divers on diving vacations in the western Caribbean. It was anticipated that these customers would be offered as many as 17 dives in a four day period during these week-long cruises.

Initially, I was asked to design a high speed, high volume air filling system, design and build the custom dive boats and consult with the ship's engineering firm on a gantry crane for launch and recovery, hire the diving and medical staff, write the operations manuals, develop the training programs and refit a 60 inch multi-place, multi-lock recompression chamber for installation aboard the vessel.

My first operational concern was the large number of dives to be offered in such a short period. This program called for four dives per day for four straight days, adding a night dive during the same period. This meant that I would be facing as many as 2,720 dives by recreational divers each week if the company was successful in realizing its market. To this figure would have to be added the diving schedules of the 28 professional staff members; approximately 500 additional dives. Looking at the possibility of handling over 3,000 man dives per week posed obvious operational concerns. For the proper perspective, many top dive resorts do not conduct that much diving in a whole year!

Addressing the issue of expected incidences of decompression sickness (DCS) left many unanswered questions. No one has ever seemed to be in agreement on the statistical incidence of DCS in recreational divers. Several "experts" were polled on this issue and a wide spectrum of "qualified" responses were received. One respondent predicted 12.5 cases of DCS per week. This type of feedback was daunting to say the least.

This paper addresses the data compiled after one year of operation of the vessel in that market. Statistics presented were recorded March 4, 1989 through March 1990. 77,680 man dives were logged during this period.

### **The Multi-Level Question**

Traditional resort diving operations typically deal with far smaller numbers of divers and rarely conduct dive operation schedules that permit up to four dives per day. Virtually all resort diving in the summer period of 1988 was conducted by "divemaster log sheets", handwritten at the dive site. Most dive planning was performed using conventional dive tables with the Haldane model U.S. NAVY Tables seeing the widest use.

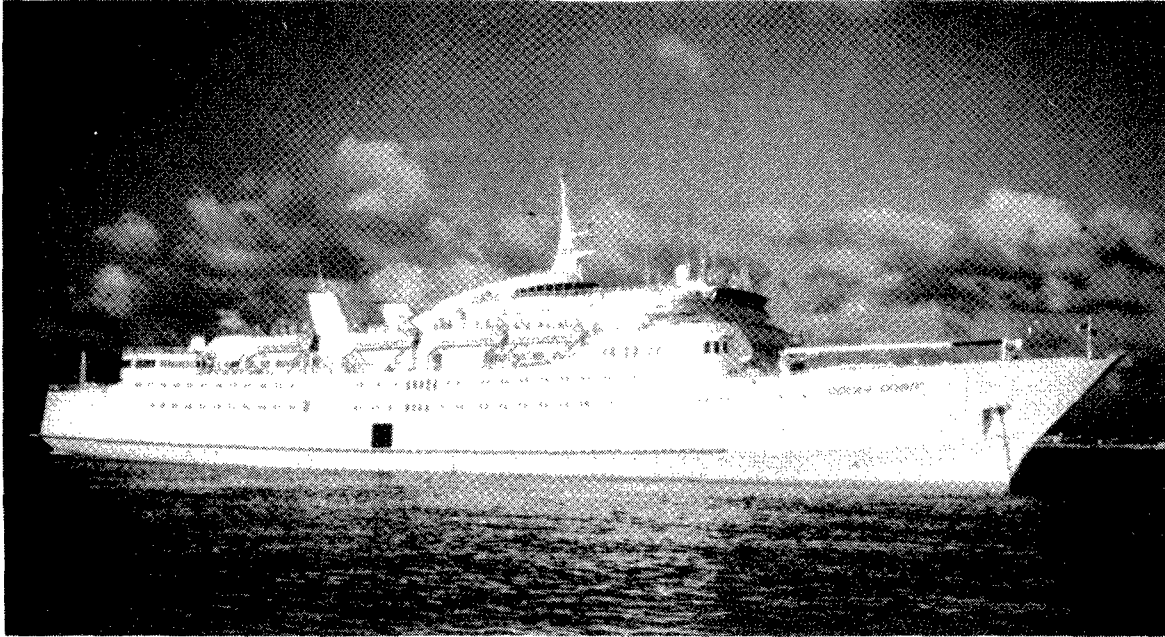

**Figure 1. Above: 457 ft. dive cruise ship OCEAN SPIRIT operated by Ocean Quest International from March 1989 to September 1990. Below: Several of the ten 32 foot dive boats deployed from the ship picking up divers from the port embarkation platform. Each boat averaged 16 divers making 4 dives a day.**

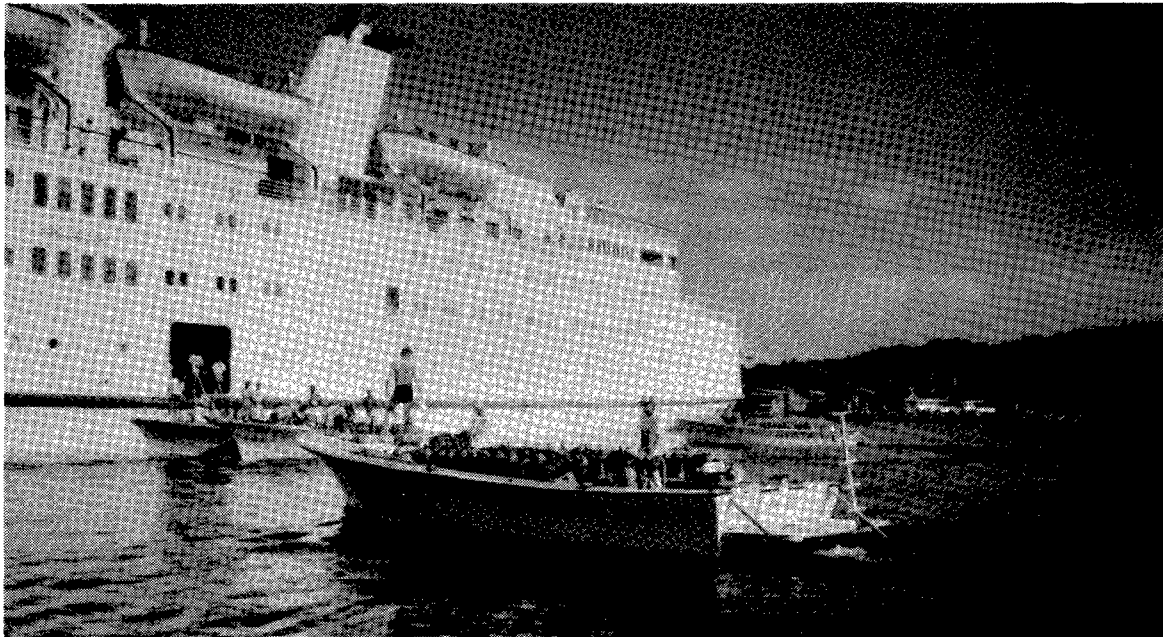

Given the extraordinary number of dives that this company was committed to, I wanted to provide every possible safety edge and discipline of logging dives. The basic weakness of most recreational dive profile logs has been two-fold:

1. recreational divers are notoriously poor record keepers with regard to times, depths and surface intervals; and
2. several surveys and volunteer test studies have provided evidence beyond doubt that the majority of divers cannot calculate repetitive dive profiles correctly.

One issue that came up almost immediately was whether any meaningful dive profiles could be allowed if the divers exclusively used "square profile" computational methods. In most circumstances, it proved unworkable for a four dive schedule in the time parameters allowed for the ship's strict sailing routine. Therefore, the viability of "multi-level" profiling became interesting. We felt that this method was best accomplished through the use of dive computers and eventually our program showed almost 57% of recreational divers utilizing these devices (Gilliam, 1991).

By the Fall of 1989, we made minor changes to the ship's itinerary and had modified the diving schedule to average 13 dives per week. However, the numbers of divers had increased dramatically during certain periods and we frequently handled in excess of 200 divers per week. We had actually gotten to the point where we considered 100 divers a week to be a slow period. One day in December of 1989, we logged over 1000 dives!

#### A Summary of Data

- Through the period of March 4, 1989 to March 4, 1990, we conducted a total of 77,680 dives including customers and professional staff.
- During that period, we treated seven cases of DCS for dive customers and none for staff. All of the DCS cases were presented by divers using tables. Of the 7 divers clearly symptomatic of DCS, all were successfully treated in the ship's recompression chamber with full resolution. Five of the seven divers with DCS hits were diving within the limits of their tables and can be categorized as "undeserved hits". All seven patients who were treated for DCS had limited dive experience; usually less than 40 dives. Of the seven hits, 4 were female and 3 were male. Five of the seven cases had profiles of less than 100 fsw. In four of the seven cases, ascent rates in excess of 60 ft./min. were reported. In five of the seven cases, no "safety stop" at 15 fsw was taken.
- Diver ages ranged from 9 years old to 72 years old. All DCS hits fell in the 26 to 45 year old range.
- Approximately 57% of our dives were done on computers (total: 44,277). There were no attributable hits on any divers using dive computers correctly.
- Divers averaged three dives per day although a significant number (over 20%) of customers made over 5 dives in one day if weather permitted. Divers were instructed to limit their diving to a maximum of 130 fsw with a 30 foot per minute ascent rate above 60 fsw or to conform with their dive computer's ascent rate, whichever was more conservative.
- The great majority of diving was conducted with exposures of 100 feet or less. Reverse profiles were conducted by many divers with no adverse effects reported. Computer divers frequently admitted to reverse profiles in their personal dive scheduling.

- In conjunction with some other ongoing research projects, members of the professional staff made over 600 dives to depths of 250 fsw. All were calculated by the dive computer (Bühlmann model) and repetitive dives were performed the same day. There were no incidences of DCS.
- The author made over 625 dives in the one year period including 103 below 300 feet with one penetration to 452 fsw, a new AIR depth record. All decompression schedules for dives up to 300 feet were derived from the DACOR MICROBRAIN-PROPLUS computer (Bühlmann model). Below that depth, the author used custom proprietary tables. No DCS hits were recorded.
- No hits were recorded for the professional staff. Most members averaged 500 to 725 dives during the one year period. Age span was 21 to 43 years old with approximately one third of the staff being female. Dive staff members averaged between 11 and 15 dives per week.
- No hits were recorded during the first two days of diving.
- Although not sanctioned, we had knowledge of recreational divers routinely diving in excess of 130 fsw while conducting their own dive plans. Over 40% of the computer owners questioned admitted to frequently diving below 130 fsw, several to depths in excess of 200 fsw. No hits were recorded.
- Water temperature ranged from 77° F to 85° F and cannot be considered a factor in any DCS hit.

#### Incidence Rate of DCS

With 77,680 dives in the data base and 7 DCS cases, the incidence rate is .00901% or approximately one in 10,000 dives.

If only the table user group is considered, the incidence rate is .02%, 2 in 10,000 dives.

The computer user group had a zero (0%) incidence rate.

#### Discussion

Originally, this project was to keep records for a six month period. This was expanded as the diver population aboard ship increased. Of particular interest was the lack of DCS incidence in computer users and in the more "aggressive" experienced diver population. Precisely the diver group that we suspected was most at risk to DCS proved to be the safest.

We observed the computer diver and experienced aggressive diver groups to be far more disciplined in their regard for ascent rates, "safety" and/or decompression stops, and general watermanship skills. Most were also more attuned to proper hydration and generally refrained from alcohol consumption during the evening periods. The decompression algorithm employed by their computers were generally more conservative than the typical Haldanian U.S. NAVY models. The great majority of our sample group used the Bühlmann model which in direct comparison of "square profiles" is dramatically more restrictive than U.S. NAVY Tables or any other tables then in use.

Overall, the low incidence of DCS surprised all involved in the record keeping project. Taking the whole group into perspective with the benefit of hindsight lends several observations which may further account for the excellent DCS safety record. The ship's schedule had recreational diving customers board the vessel on a Sunday and depart that afternoon. Monday was an orientation day with a safety lecture required for all divers. To ensure their attendance, it was made clear that dive boat assignments would be conducted immediately following the conclusion of the one hour orientation. Fear of being left off the boat list or not being assigned to a favorite boat crew provided virtually 100%

cooperation in attendance. Also, since the ship was at sea and no other diversions offered, it was relatively easy to lure divers. We tried to get sport divers to regard their role in our operation as a mutually cooperative one with the professional staff. We avoided any domineering or "lecture" attitudes and endeavored to communicate safety and environmental protection information with a "we need your help to best serve you" approach that was generally well received and not resented. Many divers reported our orientation to be more instructive and less intimidating than typical resort "tirades", no matter how well intended. Orientation served to acquaint the divers with our ship's diving operations but also had detailed general safety recommendations that we felt should be emphasized to all recreational diving groups in resort settings. Of particular importance was reinforcing disciplines of ascent rates and "safety stops" at the 15 fsw level for at least five minutes. Most recreational divers initially have little concept of safe ascent rates even if given instruction during their entry level scuba training. Most seem to understand that slow ascents are important but fail dismally to execute proper ascents in the field. We overstressed adherence to a 30 ft./min. ascent rate at least in the last 60 feet of the water column.

The "safety stop" was further emphasized and we felt that even if ascent rates were compromised that instilling the "safety stop" ethic would at least slow the divers down while approaching this ceiling. Many other resort operations stress returning to the dive boat with anywhere from 700 psi to 500 psi remaining in the diver's scuba tank. We departed from this conventional instruction and urged divers to arrive at the safety stop level with sufficient reserve for a 5 minute "hang" and then to use the remaining air for additional stop time saving only a small reserve for the easy return to the surface. Each boat was equipped with a weighted 20 foot PVC pipe bar hung from the dive boat's side at 15 fsw. This afforded an easy and comfortable platform for "safety stop" observance and the large size of the "Deco-bars" accommodated as many as a dozen divers at once.

We found that a significant number of divers did not realize that their ascent rates were excessively rapid. Typically, we would time divers in ascents ranging from 100 to 125 ft./min. and upon questioning, the diver would express surprise and voice the opinion that they thought they were conforming to 60 or even 30 ft./min. rates. Most divers simply find these recommended rates to be ridiculously slow (from their perspective) and only through continued education and patient explanation will the disciplines of proper ascents be applied. Most important however, is to establish a non-confrontational relationship with recreational divers so a willingness to learn will evolve. Our staff was trained to emphasize all safety recommendations again daily on the dive boats and to observe divers in the water. Tactful suggestions and critique were to be offered in areas where divers could improve technique. We had great success with these methods and felt reasonably confident that 90% of our customers were complying.

Due to the temptation of being aboard a cruise ship where the availability of alcohol was ever-present, we felt obliged to remind divers that alcohol consumption the night before a heavy diving day was ill-advised. Surprisingly, we met with little problem from our diver populations in this regard. Most got their "partying" out of their systems on the Sunday night departure from the U.S. port and refrained or adopted modest alcohol attitudes until the four days of diving were completed. Staff example went a long way to promoting compliance. Our professional divers generally observed a voluntary 11:00 pm curfew on evenings before diving. Since most diving would begin as early as 8:30 am, we encouraged a good night's rest in customers and staff. For staff, it was a necessity due to their heavy diving and work schedule.

Another strong emphasis was placed on proper hydration of divers. We recommended consumption of non-carbonated beverages, but suggested staying away from orange, tomato and grapefruit juices due to their tendency to initiate sea sickness in many divers. Each boat was supplied with large containers of cold fresh water and unsweetened apple juice. Each boat crew encouraged consumption of these fluids between dives during the course of the diving day.

We also included a detailed segment on recognition of DCS symptoms. Since we had a fully staffed and functional recompression chamber aboard we made our guests aware of its location and that we used it not only for training programs but that we expected to use it for treatments as they presented. Denial of symptoms and subsequent delay of treatment has always been a major problem in recreational diving. We tried to make it clear that DCS has a certain statistical inevitability and that no stigma or "blame" would be placed on an individual who reported problems. We let our divers know that each boat captain was trained in diver first aid and each boat was equipped with O<sub>2</sub> units equipped with demand regulators to insure delivery of 100% O<sub>2</sub> if needed. There was no charge for the O<sub>2</sub> or for evaluation by the author and diver medical technician. In fact, we did not charge for tests of pressure or treatments.

As a result of the orientations, we overcame the traditional reluctance to report symptoms and in many cases found ourselves burdened with evaluations of numerous non-DCS related muscle strains etc. But at least our divers were enthusiastically coming forward to report even slight perceived symptoms. We would always prefer to err on the side of caution and the few cases of obvious non-DCS injury were welcomed in preference to denial attitudes so frequently prevalent in the past.

### Hyperbaric Chamber Facility

We acquired a 60" PVHO classed recompression chamber which we completely refitted for use on the ship. We purchased the chamber and essentially discarded everything but the pressure vessel. Two staff members then replaced all fittings, installed a new radio communications system including two sound-powered phone handsets, 6 new BIBS masks with overboard dumps for O<sub>2</sub> delivery, two new O<sub>2</sub> analyzers, fire suppression system, 50/50 NITROX therapy gas, new gauges and timing devices. All ports were removed and replaced along with all hatch o-rings. The entire unit was cleaned and repainted white with all gas lines color coded.

When completed, Dick Rutkowski of Hyperbarics International examined and certified its readiness. Rutkowski was also used on three occasions to conduct specialized training for chamber operators and technicians. The author and two other staff members had extensive prior chamber operation experience from military and commercial backgrounds and we had one DMT graduate from Oceaneering. Training runs and protocol discussions were conducted weekly with the majority of the dive staff participating in various roles in the chamber's operation. This provided a continuing education process and ensured operational readiness of all systems and staff. Periodic test cases were presented by passenger volunteers coached to appear with DCS symptoms to present staff with "real life" scenarios to react to.

Additionally, we developed the first recreational diver certification program in Accident Management/Introduction to Hyperbaric Chambers. This author wrote the course with the intent of involving divers in an intensive hands-on learning situation that included field evaluation of diver patients, O<sub>2</sub> administration, patient handling and transport, record keeping and actual dives in the chamber including breathing from the BIBS masks with dives to 60 feet. This program was approved by both PADI and NAUI and hundreds of divers participated in it during 1989 and 1990. This program was scheduled for a travel day at sea after conclusion of the diving program on Friday afternoon. Most divers expressed the opinion that this course made them far more aware of pre-disposing factors and health conditions to DCS and AGE, and appreciated the in-depth accident management modules especially with O<sub>2</sub>.

Our protocols called for very aggressive diver treatment. Divers reporting symptoms were placed on 100% O<sub>2</sub> by demand mask and immediately transported to the ship for evaluation by the author or DMT. Significantly, we had approximately 12 cases of symptomatic DCS that relieved completely during the 100% O<sub>2</sub> breathing period during transit from dive site to ship. As is standard practice in the commercial diving industry, we have not counted these cases as confirmed DCS incidents since they

were not confirmed through a recompression test of pressure. However, the importance of 100% O<sub>2</sub> delivery by demand mask cannot be over-emphasized.

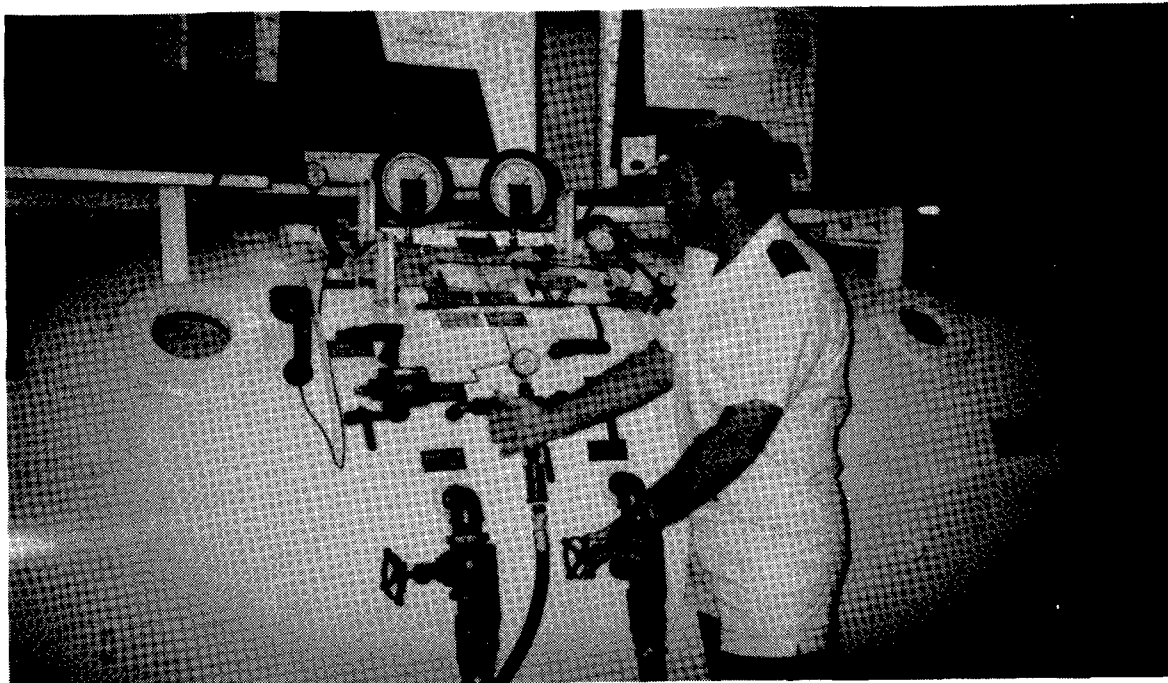

**Figure 2. Above: Director of Diving Operations, Bret Gilliam, shown operating the ship's 60" multi-place multi-lock recompression chamber. Unit was fitted with 6 O<sub>2</sub> BIBS with overboard dumps, full communications systems, 50/50 NITROX therapy gas, dual O<sub>2</sub> analyzers and fire suppression. Chamber was used extensively for training of professional staff, medical staff and seminars, and sport diver programs. All patients treated with full resolution. Lower photo: Inside tender Mark Globerman on sound powered phone handset to chamber supervisor.**

With regard to treatment Tables, it is my firm opinion that use of U.S. NAVY Table 5 is not appropriate for recreational diver DCS presentations. Virtually all sport diving DCS cases I have treated in my career will show Type II symptoms upon close examination. In many cases, Type I symptoms present and the patient may complain vigorously of muscular/skeletal "pain only" symptoms only to discover further evidence of Type II numbness, etc., once the "pain only" symptoms have abated. The masking of Type II DCS has led to improper and insufficient treatment on Table 5 when a Table 6 with extensions may have been called for. We aggressively treated all presentations with Table 6 and used Table 5's for clean-ups when initial treatment did not produce full resolution. Under these protocols we had complete resolutions of all patients.





### Conclusions

Examination of these data suggests that recreational divers' incidence of DCS is far lower than originally expected. In this diver population certain factors may have contributed to their safety record. These include aggressive counseling through orientation to proper hydration, rest and low alcohol usage. Of primary importance was the constant stressing of slow ascent rates and "safety stops". Additionally, professional dive staff members were trained to observe and tactfully correct bad diving habits and to assist with review of dive planning and repetitive table use. The importance of dive computer use in contributing to more accurate dive profiling and use of more conservative decompression algorithms clearly played an important role in limiting DCS incidence rates. The fact that the dive computer group made 44,277 man dives with a zero incidence of DCS must be considered significant. Interestingly, the most aggressive group of divers making the deeper and largest number of repetitive dives had the best overall safety record, against all conventional wisdom. This would seem to be due to the experienced divers' greater discipline with regard to ascent rates, observance of "safety stops" for long hangs, proper hydration practices, better knowledge of table and/or computer use, and overall better diving and watermanship skills.

Furthermore, aggressive use of on-site O<sub>2</sub> administration by demand mask may well have relieved other unconfirmed DCS hits. On-site chamber treatments that offered tests of pressure and evaluations usually within two hours of symptom onset certainly contributed to the 100% resolution rate for patients. Finally, the encouragement of prompt symptom reporting with no associated peer or professional "blame" or stigma attached is refreshing in a recreational diver community that has historically been infamous for symptom denial.

In the case of the professional dive staff some validity to the hypothesis of "adaptation" must be given serious consideration. These individuals dived aggressively for four straight days, then received three days off before resuming that schedule. Most made between 500 and 725 dives in the one year period. Many routinely performed diving in the 250 fsw range or greater with subsequent repetitive dives and yet no DCS hits were recorded in any staff. The "multi-day skip" suggestion deserves further investigation.

Included as an appendix to this paper are some sample DCS case histories. It should be noted that for statistical sampling the database presented here only considers the ship's recreational diver population. Other patients presented for treatment from time to time from other local resorts, commercial divers engaged in fishing using scuba, etc. One of these cases is included in the appendix because it is of interest due to its extreme repetitive exposure.

### Selected References

- Emmerman, M.N. 1989. "If You Fly: The Divers Dilemma". Discover Diving, Sept./Oct.
- Gilliam, B.C. and R.K. Hill. 1990. A comparison of the Incidence of Decompression Sickness in Men and Women Divers Using Decompression Tables and Diving Computers for 77,680 Dives. W. Jaap (ed.). Proceedings of *Diving for Science...1990*. American Academy of Underwater Sciences, Costa Mesa, CA.
- Gilliam, B.C. 1990. "Avoiding the Bends". Scuba Times, Nov./Dec.
- Gilliam, B.C. 1991. "Computer vs Table Usage: 12 Months Data". SOURCES, NAUI
- Gilliam, Bret C. 1990. "How Safe are Diving Computers?" IN DEPTH.

- Gilliam, B.C. 1991. One Year Database of Sport Diving Exposures: Comparison of Computer vs. Table Usage". H. Vidars and F. Wells (Eds.). Proceedings of the 1991 International Conference on Underwater Education, Montclair, CA.
- Gilliam, B.C. 1989. "Sports Diving Computer Use: Field Data" SOURCES, Sept./Oct. NAUI, Montclair, CA.
- Gilliam, B.C. 1990. Summary of Diving Accidents 1989 for Ocean Quest International. OCEAN TECH release 3-90
- Hill, R.K. 1990. "How Well Do They Do It?; A Survey of Sport Divers' Ability to Work Decompression Problems". Proceedings of XV Meeting of European Undersea Biomedical Society.
- Rutkowski, R. 1988. Treatment Tables. HYPERBARICS INTERNATIONAL release.

### Appendix - Sample Case Histories

#### CASE #1

Patient presented with numbness and tingling on right side localized in foot, ankle, wrist and forearm. Skin mottling also noted. Numbness had become progressively worse since making 2 dives in Cozumel with profiles: 60 fsw for 32 minutes; approximate 1 hour surface interval followed by second dive to 48 fsw for 25 minutes. Patient was in fourth day of repetitive diving vacation with over 24 hours since previous day's diving. Dive procedures were unremarkable with normal ascents and no work. Water was 79°F with excellent visibility although a moderate current was prevalent in both dives as is typical for Cozumel diving conditions. Symptoms developed within one hour of surfacing from second dive but were not reported until approximately 8 hours later as they progressively worsened. Patient did not believe he could be bent.

A test of pressure was performed and after a 20 minute O<sub>2</sub> breathing period by BIBS mask at 60 fsw in the chamber the patient reported complete relief. A standard treatment Table 6 was followed with complete resolution.

Patient was calculating dives using standard NAVY Tables. 43 year old male with no obvious physical detriments; diving experience included frequent recreational diving in the four years since he was certified.

#### CASE #2

Patient presented with shoulder pain after making two dives in Cozumel with profiles: 76 fsw for 25 minutes; approximately 1 hour and 10 minutes surface interval with second dive to 58 fsw for 32 minutes. Ideal diving conditions with typical Cozumel current. Symptoms developed approximately 2 hours after surfacing from second dive but not reported until nine hours later when pain had progressively worsened.

A test of pressure was performed and after a 12 minute O<sub>2</sub> breathing period by BIBS mask at 60 fsw in chamber, the patient reported complete relief. A standard Table 6 was followed with complete resolution.

Patient was calculating dives on PADI RDP Tables. Patient was 44 year old female: overweight by approximately 35 pounds and in generally poor physical condition. Reported prior injury to shoulder where initial symptoms developed. Infrequent diving experience although certified for five years. Dive buddy reports poor ascent technique and poor buoyancy control throughout dives.

### CASE #3

Patient presented with severe symptoms including inability to walk, bilateral paresthesia, incoherent speech, and collapsed during examination. Patient was immediately recompressed to 60 fsw in chamber and put on BIBS mask with O<sub>2</sub> with no relief. Compression was continued to 100 fsw on air where relief was reported of most symptoms. Patient was decompressed to 60 fsw and a standard Table 6 was followed with complete relief.

A history was obtained of his previous day's diving. Patient was a male Mosquito Coast Indian professionally employed as a lobster diver using scuba gear in the Bay Islands of Honduras. He made between 10 and 12 dives in a nine hour period to average depths of 125 fsw or greater. Procedure was to dive until tank was exhausted and then make a free ascent. Repetitive dives were performed non-stop in this manner until the diver began to feel numbness and tingling in his right arm and shoulder. Another dive was made and these symptoms relieved underwater and he continued diving until he ran out of air and ascended rapidly. Almost immediately upon surfacing he noticed pain in his legs and then progressive numbness and tingling. His boat was over 12 hours from Guanaja (Bay Islands) and on the trip in he consumed a large quantity of a native alcoholic drink and ultimately passed out.

His diving buddies brought him to the OCEAN QUEST ship when they heard that there were divers on board who "knew how to fix divers when they get twisted". The patient was paddled out to the ship in a dugout canoe by his companions who related his profiles.

Although he was completely relieved following a Table 6, he was advised to remain on board the ship for transfer to Roatan's chamber facility for observation for recurrent symptoms. At this point the patient became highly agitated and insisted on leaving the ship. When attempts were made to restrain him in order to have his companion better explain (as interpreters) the seriousness of his condition, he attempted to jump over the side into the water and swim to shore. The diving officer and the chamber supervisor (Mr. Gilliam) explained that he could leave at any time and urged him not to return to diving for at least a week and to obtain a medical examination. Patient chose to depart immediately by canoe with his companions. Apparently his immigration status was questionable and prompted his anxiety about transfer to Roatan.

In spite of warnings from the ship's dive officer (Mr. Gilliam) it was reported that the patient resumed diving two days later and still continues to dive with no apparent further problems.

### CASE #4

Patient presented initially with mild tingling in both hands. He was held two hours for observation and upon re-examination was found to have marked progression of tingling and numbness, fatigue. Also, his disposition had altered and he was becoming lethargic and unstable in walking and maintaining normal balance control.

Patient had made a total of nine dives all within NAVY Table limits in the three previous days. He had a 20 hour interval before resuming diving on the fourth day. His profile was: 51 fsw for 58 minutes, 67 fsw for 43 minutes, and 95 fsw for 46 minutes. Patient had declined to dive under the supervision of a ship divemaster and was diving with his buddy using supposed profiles obtained from NAVY Tables. They could not provide accurate surface interval information. Symptoms developed within one hour of surfacing and he immediately reported to the ship's diving officer upon returning from the Mexican Cozumel diving boat. This was approximately two hours after the last dive.

Patient was given a test of pressure and reported complete relief after 10 minutes of O<sub>2</sub> by BIBS mask at 60 fsw in chamber. A standard Table 6 was followed with complete resolution.

### Recreational Diving Session Discussion

Peter B. Bennett, Moderator

- J. Lewis: You said there was a higher incidence of risk with multi-day diving and yet you made some comment to the effect that with the liveboards, there seemed to be less.
- P. Bennett: The general philosophy that we have from the data, as I tried to show you, is that in our analysis multi-day diving comes up as one of the risk factors and every fourth or fifth day towards the end, you will get a higher incidence of decompression sickness. In fact, Brett Gilliam will tell you the cases they had at Ocean Quest came later in the week and yet, if you measure for bubbles with Doppler, they are present on Monday and Tuesday and are gone by the end of the week.
- J. Lewis: So, you're suggesting you're adapting as far as bubbles are concerned and yet the decompression sickness is coming up on the Thursdays and Fridays.
- P. Bennett: On the Friday perhaps or just before we're flying off someone says, "I've got a problem!" It's not on the Monday and Tuesday, so there is something not quite right here. I don't know what it is.
- M. Emmerman: How did you verify the depth limits? Did you check them against the computers, or what did you do?
- B. Gilliam: In most cases, we could take it directly off the computers because the computers, of course, would lock in the maximum depth and the models we were using had a six dive recall. Our staff had instructions to record every dive, either the way it was reported to them, or the way they could verify it directly off either a maximum depth indicator on a depth gauge or dive computer. So, I think that the accuracy of those statistics is fairly well established. Incidental to this, if we had asked people in the beginning the first day of the program or prior to diving, how many of them were going to exceed the 130 foot sport diving limit, no one would have admitted to it. When we tried to establish what people had really done, the only time we got the straight answer was once their diving was over, and they were riding back to the ship, which is when they talked to us. That is why I had some suspicions that the liveboard boats reporting to Karl Shreeves and Drew Richardson, were not actually doing what they were reporting.
- P. Bennett: I was interested to notice the comments on rate of ascent, which our other speakers have not spoken about. The depth limitation of 130 feet, as Brett mentioned, is totally ignored; 200 foot diving is not as uncommon as we would like to think. Out of Brett's data came that a lot of the accidents were with the novice divers who perhaps were making their first 20 dives. We find the same thing. And, that when the accident does occur, it is the first dive of the day. So, there are certain similarities coming out of the data which we have.
- A. Galerne: Have you tried to make some differentiation between men and women divers?
- B. Gilliam: Only to the extent that if we had someone who was going to present for full treatment, or who presented with symptoms for test of pressure and other neurological evaluations, then we made very specific distinctions: Age, sex, diving patterns, etc. But, in the overall diver population, taken generically, we found that we had approximately a 33 to 40 percent grouping of females in the total population. That was true also for the professional staff. I think we are seeing more women diving, but that is the broadest statement I can make because I was not trying to sample the data that way. I was trying to take the whole general database, sample for one year and then see what the data told me, not necessarily trying to prove what the data might be in advance.
- A. Galerne: My second question is what did you do on the fitness standpoint?
- B. Gilliam: That varies so widely across the curve that it is at times terrifying. You will see people come on-board that probably should not be walking. We had a woman that was so grossly obese that the first time she climbed on one of the aluminum (schedule 80) dive ladders, she broke the first two rungs off. In my paper I have noted that I felt that in almost every incident I treated there was some level of an ignorance of safety stops and ascent rates, but also the obvious physical fitness abuses. Obesity and smoking are factors we saw that we would obviously like to change, but we can't change anybody's personal habits in a short time.

- A. Galerne: Did you see a correlation between fitness and accident?
- B. Gilliam: No, unfortunately not. We treated seven cases in our diver population and probably about another ten that were referred to us simply because we were the only treatment facility in the area. Unfortunately, most of the people that we saw with the worst hits were little skinny guys, but they were mostly commercial divers who were referred to us.
- A. Galerne: You have never seen a skinny whale, have you?
- B. Hamilton: Would you elaborate a little bit on this reverse order of diving. I have always been suspicious of this as being a myth rather than really valid, although there are a lot of people who swear by it. You now have some data to add to it.
- B. Gilliam: We had dive boats dealing with a population of divers that averaged between 160 to 225 divers. Because of that and because we had a very strong environmental policy of site rotation, in many cases divers would not necessarily get to go where they wanted to go. And, particularly if you had experienced and very highly motivated photographers, they would specifically say, "Well, I want to do this dive!" so we would give them that dive. Now, that might have been a 60 foot exposure on an area that had particular reef life of some significance. Later in the day, they would have options including several decent wrecks that were available, usually in 120 or 130 foot range. In many cases, they would opt to go do those and so those guys were doing it all the time, every week. Because of our environmental practice of not dropping anchor, all of our anchors were placed by hand and this meant that we had some severe spike bounce dives on our staff. It was not uncommon for us at all, particularly if anchored on the atolls in Belize to go into the water, take a 35 to 45 pound anchor and make a rapid drop to 130 to 150 feet, secure the anchor in an area where we would not impact the living coral and then begin an immediate ascent back to the surface. I would not even change tanks, reorient my group, give them a sketch and back into the water again. This meant that the anchors also were hand recovered. Especially in our professional diver population, we made five dives during the day that required ten dives to set and recover the anchor, usually with these sharp spikes, almost all these ended up being reverse profile dives simply because of the way the dives were going to be conducted. In the vast population of the sport divers, we had significant numbers of them doing reverse profiles all the time. We basically had to say we did not recommend it, to protect ourselves legally, but it was done consistently.
- M. Emmerman: What was the surface interval experience you had and secondly, what was the surface interval experience of the seven people who were hit, versus the others?
- B. Gilliam: The average surface intervals for most of our people were between 45 minutes to an hour-and-a-half. For the rest of the diving, we were looking at five dives or more per day. In many cases during the mid part of the day, there was a long sit period of usually two hours and we tried to get that during a period when lunch was going to be eaten. We were extreme in the practice of stressing proper hydration. We had apple juice and water on the boat and tried to de-emphasize carbonated beverages. We did not offer coffee and we did not offer, of course, any alcohol during that sit time, which is the longest we usually had. Then they would resume diving again, the average time probably 45 minutes to an hour-and-a-half for the most aggressive divers. On those that got hit, however, significantly, there was nothing that would have told us that their surface interval had anything to do with it. They were within their table limits and they all got hit on the third or the fourth day after relatively benign diving practices. Most of these people were new and relatively inexperienced divers. Most of them averaged two dives a day and got hit following the second dive on the third day. The risk group that we had identified and specifically targeted for our people to watch had no problems. We really cannot explain it except to say that perhaps there is some level of adaptation taking place and perhaps because we were so aggressive in our efforts at slow ascents, safety stops and hydration. We also stressed the reporting of symptoms. We had a lot of evaluations, but we always masked them with 100 percent demand oxygen. In many cases, by the time that they were actually presented to me at the chamber for evaluation, there was no significant relief on the test of pressure, so we just simply observed them and off they went. It may very well be that the 20 or 30 minute surface oxygen breathing period cleaned them up.

- Karl Huggins: Max, in your data, what percent of your dives do you think were decompression dives, especially the 25 meter plus since that represented almost a third?
- M. Hahn: We didn't ask for decompression dives because what decompression dives are strongly depends on what means you use of defining decompression, what kind of table or what kind of dive computer. Take the same dive profile by U.S. Navy tables where you might go down to 36 meters for 15 minutes. This is no-decompression on the U.S. Navy tables, whereas the same dive with a German table or some computer, has a stop for maybe ten minutes at three meters. We didn't ask for that. But, I estimate that the number of decompression dives in all these dives is rather small because deep diving is concentrated on rather few people doing that regularly. Many divers in fresh water go deep to 40 meters rather quickly and then follow the bottom until they are on the surface. This takes 30 minutes, so you have a strongly triangular profile which by computer is far inside the no-decompression limits.
- D. Harper: Brett, you said that the cases on your boat were all relatively inexperienced divers. What is relatively inexperienced and does this mean that perhaps there need to be more training dives made for basic or advanced open water certifications?
- B. Gilliam: We define "relatively inexperienced" as people with 40 dives or less. But certainly what we were finding in the diver populations is that as the divers were more experienced and verifiable either through anecdotal reporting or through their log books, unquestionably these divers had overcome the certain fascination that goes on initially with just trying to discover diving in general and then progress it to far greater disciplines when it came to dive technique, ascent rates, and hydration. All these things that are almost secondary to a lot of people becomes very important. In our opinion, it is very, very difficult for us to consider a diver as experienced with anything under that level. There is a very good trend in the industry to try to get people into continuing education courses. The open water diver progresses to be an open water II diver or an advanced diver. But, the problem we find is that in many cases, divers are presented with entry-level certifications and at that point simply don't have enough experience to dive all by themselves. They need a great deal of supervision and I would like to see the entry-level programs expanded a bit on a regional basis because it's fairly easy to learn to dive in warm, clear, calm water in ideal conditions with no thermal restrictions and confining suits. But, take the same diver that is being trained in the Northeast or in the surf in California, who needs a lot more acclimatization time to be able to be comfortable with his basic skills. We have all seen them on the boat. Some of these people can barely get themselves dressed, much less be able to perform in the water. I think they need more time to err under qualified supervision before we turn them loose in the diver population. But, this is always the pet peeve of all of us that are in the resort business. We get everybody's mistakes and then we get to clean them up.
- P. Bennett: The DAN data certainly shows that a large preponderance of the accidents are occurring in the people who have only made up to 20 dives, which means they are still very much in the learning process. The question we perhaps have to ask is in terms of the numbers of diving accidents DAN reports. I wonder whether or not that is due to the fact that these people are not being controlled. Their rates of ascent are not what they should be and they are not making the proper stops at 15 feet for 3 to 5 minutes. They do not know how to read the tables as well as they should. All these things make our data a bit askewed and we need to remember that when we are talking about the information. PADI's analysis showed that the liveboards are diving more - 54.6 percent between 31 and 60 feet, as compared with resorts only 31 percent between 31 and 60 feet. Depth changes like that can be very relevant to what we're worrying about. Are liveboards diving more deeply? Well, certainly 15 percent are diving deep compared with 10 percent at 91 to 130 feet and most of the accidents we get are deeper than 80 feet. But, it's generally suggested that if you keep less than 80 feet, you are not going to get into much trouble. So, depth is in there as well. There's a whole complex range of issues which we have to try to tease out. I'm not quite sure how we're going to do it.
- D. Harper: Can we consider the experienced diver question?

- M. Hahn: I can only say that we found that from screening the insurance files that at least half of the DCS cases we had were due to not obeying computers, not obeying tables, or other problems where the performance was different from what safety regulations would call for. The remaining number is so small that you cannot split it up into any groups.
- D. Richardson: Obviously, it is a very subjective opinion of what constitutes experience. A couple of things to note here in terms of who the consumers are that are coming to the recreational industry these days. It is the same type of person that has a variety of choices, scuba diving is one of them. In terms of leisure time activity, you have everyday folks. We have the 9 to 72 year olds and the varying physiological makeups are pretty common. So, we're dealing with people who choose to make a diving vacation this year, perhaps a tour next year, maybe a ski package or both during the course of the following year. It is just one activity. Experience for them is difficult and training by the way, for virtually all agencies is performance-based which means the instructor's obligation is ensure they have mastered certain motor skills in cognitive areas prior to certification. There is some erosion of motor skills in all of us for a variety of skills and of course, knowledge, if you do not keep it up. A lot of experience for somebody may be diving for ten years logging nine dives per year over that course of time. We all have our own opinion of what experience is. I do not know that it is simple to categorize experience in our market because we deal with a part-time diver for the most part.
- G. Egstrom: You mentioned that divers had been treated with surface oxygen and by the time that they got to you they were clean. Do you have any idea of a modification of that for the future?
- B. Gilliam: We were extremely aggressive with our oxygen procedures. We used jumbo D double cylinders on our boats with a demand valve mask equipped with a positive pressure device. In addition to that, we had a free flow mask. The theory being that we could not equip the units we had with two demand mask but if one diver was symptomatic, then perhaps his buddy might very well be too, so the asymptomatic diver could at least be put on the free flow mask at the highest rate we could give him. Our dive guides were instructed to, if they had any doubt at all, and were so disciplined to get these people to report symptoms, that if they did report them, they were masked all the way back to the ship immediately. In virtually all of the cases, and I had to evaluate 50 or 60 during the course of that period, those that had been placed on 100 percent oxygen were completely asymptomatic by the time they returned to the vessel. We would do a full neurological workup on them to the best of our ability without facilities and, in most cases, I would go to the test of pressure. However, at that point, for all intents and purposes, they had relieved. I think that the significance of oxygen delivery by the 100 percent method just cannot be overemphasized. In my military and commercial diving days, we very rarely saw 100 percent oxygen delivered, but when we did, particularly in the Type I pain only bends, we saw significant relief then. If you do not have 100 percent oxygen delivery systems on-site now, you may very well end up becoming legally negligent because we know what oxygen can do and you need to have it. The old days of the free flow oxygen are just completely antiquated.
- P. Heinmiller: As a reference point from experience, what is the minimum number of dives required to become an instructor in the recreational training agencies in the United States?
- B. Gilliam: It has changed little in 15 or 20 years. It is 40 to 60 dives I would say as the safe range for virtually all agencies. What has improved though, are the prerequisites for the various agencies to becoming an instructor, not only in open water dive time, but in terms of programmed instruction, at least an attempt to document various steps in motor skills and knowledge mastery along the way with prerequisite courses of rescue, dive master, etc. The educational campaigns of the agencies have improved.
- J. Bozanic: The requisite for NAUI instructors is about 50 dives. But, it is of interest to note as well that in the entry-level programs, it is a standard throughout the industry of five dives, one of which can possibly be a skin dive. By the time you get to advanced diver, an advanced diver by definition in the industry, ranges anywhere from 10 scuba dives to about 20 scuba dives, which is not a very high number. It is also of interest to note that the depth recommendations for the training agencies for

people at various levels are much shallower than the dives that are being conducted at the resorts and live-aboard operations. Maximum dive depths for an entry-level diver are recommended to be 60 feet and you are advised to stay within those maximum depth limitations which you have at the end of your training. For an advanced diver level, the depth limit is generally around 100 feet. You saw from the data that Drew presented, there is a lot of diving taking place at depths in excess of 80 feet beyond entry-level diver training, yet most of the people that are doing these dives do not have any advanced qualifications or hold entry-level diving certifications as their only certification.

- B. Gilliam: In a perfect society, NAUI and PADI would have the ideal training systems because people would take their initial course and then they would progress through this continuing education system. By the time they got out of that as an advanced diver they would have a fair degree of experience and certainly that that would be a great step in the right direction. The problem is that only 15 or 20 percent of divers are showing up with any credentials in excess of the entry-level card, so we can only presume when those people show up that that is what their diving experience level has been. PADI and NAUI have made tremendous efforts to move people along these directions, but there is no control over making them do it. We would really like to see people a little more experienced, but you cannot make them do it. That is the problem.
- D. Richardson: I agree with both of the prior comments. One thing to recognize is when these folks do come to the resort or the live-aboard, at least it could be said in many cases that they are diving under supervision of a divemaster. So, the recreational community recommends to divers to dive within the limitations of conditions similar to what they were trained in. If they go to a resort, they should present a log book. If a dive is being presented to them that is beyond their training, we would rather have them expand the envelope under supervision than do that by themselves with two inexperienced people. It is a good thing for the resorts that put divemasters in the water with the divers. But, of course, not all do. Some just come out and drop the divers off.
- P. Bennett: That is the ideal circumstance, of course, and we all know that is not happening. If you go out to the resorts enough people who have just completed entry-level training are down at 130 foot. That is a staggering situation to find yourself at 130 foot with less than 20 dives experience, but it is happening.
- R. Peterson: Brett, do you have any insight into the possibility that the individuals that are being hit are actually especially sensitive individuals and after their decompression sickness, do they choose another type of vacation and never become experienced divers, as opposed to the possibility that it is procedural thing that is the culprit in causing the decompression sickness? In other words, do these divers that get hit as inexperienced divers continue diving? Do you have any statistics on that?
- B. Gilliam: In my case, we tracked our divers after they left the ship because in many cases we had recommended them to Keith Van Meter at the regional DAN center for post-evaluation if they needed it, particularly with a couple of AGE cases that we had. We found that by and large they were not deterred. In fact, a couple or several of them showed up a second time to go with us and, you know, we kind of kept a much sharper eye on them, but they were not dropping out. They just kind of considered it as a unique experience and gave it another shot.
- C. Lehner: Can you describe the age of your diving population?
- B. Gilliam: Generally speaking, our population on the ship and of our total sampling was 9 years old to 72 years old, but with the great majority of the people probably to a large degree because of financial considerations falling largely in the 25 to 50 year range. But that is typical of many of the liveaboards where you are going to see higher age demographics simply because their earning potential is there. We provide a more expensive type of vacation and therefore it is financially restrictive to many people that are younger.
- D. Richardson: Relative to the age range that Brett identified where the DCS fell exclusively, was 26 to 45 years old, which seems to be demographically what the dive industry's market place typically is. In terms of training, all agencies have agreed on a minimum of age 12, although some resorts have scuba programs for younger people. But, there is no upward limit. It just depends on physical health.



**Session II - ANDREA DORIA Dives**

Peter B. Bennett, Moderator

We are going to add another flavor to the essence of the problem of recreational diving because it is becoming very evident that the recreational diving industry standard of 130 feet is no longer being applied. Divers are commonly going to 200 and 240 foot on scuba air. I am concerned to say the least, but it is very common and there is a lot of concern about what should be done. Is it going to be called technical diving? Should there be special training? How should it be controlled or not because it is there? The recreational training agencies are wrestling with this issue. Generally, they feel they should not change the standards. But, we are going to hear from Dr. Larry Blumberg of the "ANDREA DORIA" dives which are just a classic example of that.

## CLINICAL EVALUATION OF REPETITIVE DEEP DIVING BY RECREATIONAL DIVERS ON THE WRECK OF THE ANDREA DORIA

*Lawrence Blumberg*

*Roy A.M. Myers*

Department of Hyperbaric Medicine  
Maryland Institute for Emergency Medical Services Systems  
University of Maryland  
22 S. Green Street  
Baltimore, MARYLAND 21201-1595 U.S.A.

### **Introduction**

On the night of July 25, 1956, the 29,000 ton Andrea Doria, proud flagship of the Italia Line, was run into by the 11,000 ton Swedish-American Stockholm in the fog, 45 miles southeast of Nantucket. At 10:09 am the following morning, the Andrea Doria sank, coming to rest on her starboard side in 225 feet of water. Fifty-four lives were lost. Although much thought was given to raising the 697 foot vessel, no serious attempts were made (Martin and Bennett, 1977). Since her sinking, many divers have dived to explore the Andrea Doria and search for artifacts, silverware and other treasures. In spite of the harsh diving conditions, including poor visibility, cold water, strong current, dangerous marine life, and depths in excess of 230 feet seawater, there have been very few reported cases of diving related maladies. Of the four known deaths occurring among Andrea Doria divers, three were due to equipment problems and one was due to a panicked diver shooting to the surface during his 40 foot hang on ascent from the dive (Suarez, 1990). There have been no severe cases of decompression sickness as far as could be ascertained from personal communications or literature search.

The purpose of this research was to evaluate a group of divers while they made repetitive deep dives on compressed air to the Andrea Doria during the three day period of July 10, 11, 12, 1990. Attempts were made to evaluate each diver for signs/symptoms of decompression sickness, air embolism and other diving maladies. Ultrasonic Doppler measurement was used to assist in objective analysis in coordination with subjective evaluation. Post dive interviews were performed to evaluate the incidence of nitrogen narcosis as perceived by the divers.

Repetitive dive profiles were recorded for each diver. No attempt was made to influence any diver in terms of his profiles, decompression stops, use of oxygen, equipment or surface intervals. No attempt was made to interrupt the usual pre or post dive routines except for the periodic Doppler testing and questioning.

### **Methods**

Nine amateur and one professional diver participated in this study. The study took place during July 10, 11, 12, 1990 in the Atlantic Ocean, 110 miles East of Montauk, New York, aboard the vessel Seeker. The site of the dive was the wreck of the Andrea Doria. The water temperature at 210 fsw was 46 °F and remained constant throughout the diving study.

The divers in the study ranged in years of age from 27 to 47, had varying levels of education from high school graduate to advanced degrees, and had as few as 50 prior dives to as many as 1,250 logged

dives (Table I). No tests were performed to determine cardiovascular fitness or body fat. One diver (J.T.) was 5'8" and weighed 285 lbs.

Table I.

DIVER	AGE	NUMBER OF PREVIOUSLY LOGGED DIVES	NUMBER OF LOGGED DIVES >130 FSW	NUMBER OF LOGGED DIVES ON ANDREA DORIA	HEIGHT (INCHES)	WEIGHT (LBS)	DIVE COMPUTER	DEPTH GAUGE
J.T.	27	1,000	350	20	68	285	BEACHAT ALADIN	---
L.G.	34	230	100	5	69	205	BEACHAT ALADIN	DACOR
G.P.	31	500	200	39	69	170	BEACHAT ALADIN BEACHAT PRO	---
J.M.	32	50	25	1	72	175	BEACHAT PRO	---
J.H.	47	700	130	36	65	145	BEACHAT PRO	---
J.C.	38	600	200	36	73	205	BEACHAT PRO BEACHAT GUIDE	---
E.S.	44	650	70	30	68	175	BEACHAT ALADIN	---
D.B.	33	1,250	280	42	75	210	BEACHAT ALADIN	---
T.P.	30	450	300	25	71	170	----	PRINCETON
S.G.	29	450	300	50	67	160	----	PRINCETON

RANGE	27-47	50-1,250	25-350	1-50	65-75	145-285		
MEAN	34.5	588	195	28.4	69.7	190		

Attempts were made to test/interview each diver at 15 minutes, 30 minutes, and 60 minutes after surfacing from each dive. The Ultrasonic Doppler Flow Detector, Model 812, from Parks Medical Electronics was used with Doppler probe placed over the diver's heart at the third intercostal space, left sternal border, and held there for up to 2 minutes. Sound recordings were made as testing occurred. No attempt was made to have the divers perform any specific maneuvers prior to Doppler testing because the activity of climbing onto the boat and removing a dry suit plus 200 lbs. of diving gear was considered sufficient post dive exercise. All Doppler tests were recorded and read by an independent evaluator to determine the Spencer rating (0-4) for each diver for each dive.

### Results

The ten divers performed a total of 49 dives during the three day test period. None of the divers exhibited any signs or symptoms of decompression sickness or air embolism. All divers underwent Doppler Ultrasound testing after each dive. Only one diver (D.B.) was perceived as having any true evidence of bubbling, yet he never displayed any evidence of decompression sickness and completed his dive schedule without difficulty. His dive profile is shown in Table II, along with the other divers in this study.

Of the 120 Doppler tests performed, 70 or 58%, were considered to have a signal adequate to evaluate true intravascular bubbling (Dunford, 1990). As stated, one diver was determined to have

bubbled on three separate tests. The incidence of positive Doppler scores was 4.3% of the 70 Doppler tests of acceptable quality.

Table II.

DIVE #		FIRST										SECOND										
DIVER	JT	LG	GP	JM	JH	JC	ES	DB	TP	SG	X	JT	LG	GP	JM	JH	JC	ES	DB	TP	SG	
STOPS	O <sub>2</sub> at										X											
	10 FSW	5	0	5	7	4	15	4	0	0	X	10	0	10	7	4	9	11	0	5	5	
	10 FT	24	30	26	29	5	40	38	36	28	X	15	30	45	22	6	27	42	37	35	35	
	20 FT	11	15	7	11	16	18	16	16	10	X	7	10	16	6	5	8	13	15	21	21	
	30 FT	6	5	5	6	5	8	6	7	4	X	5	5	6	3	1	2	5	7	9	9	
	40 FT	3	3	1	3	1	3	5	5	2	X	2	3	4	0	0	2	4	3	3	3	
50 FT	0	2	0	0	0	1	1	0	2	X	0	0	1	0	0	2	0	0	1	1		
											X											
DEPTH											X											
FSW											X	200	210	232	203	205	204	236	233	220	220	
TIME											X	15	14	19	15	12	15	18	16	17	17	
S.I.											X	5:30	5:03	5:19	6:42	21:37	6:05	3:47	4:17	4:39	5:59	
DOPPLER RATING 0-4 POST DIVE	15 MIN	0	0	0	0	0	0	0	0	0	X	0	0	0	0	0	0	0	0	1	0	0
	30 MIN	0	0	0	0	0	0	0	0	0	X	0	0	0	0	0	0	0	0	0	0	0
	60 MIN	0	0	0	0	0	0	0	0	0	X	0	0	0	0	0	0	0	0	0	0	0
	SYMPTOMS											X	0	0	0	0	0	0	0	0	0	0
												X										
DIVE #		THIRD										FOURTH										
DIVER	JT	LG	GP	JM	JH	JC	ES	DB	TP	SG	X	JT	LG	GP	JM	JH	JC	ES	DB	TP	SG	
STOPS	O <sub>2</sub> at										X											
	10 FSW	0	5	10	7	10	10	6	0	5	X	5	10	5	5	10	5	15	15	10	10	
	10 FT	27	30	45	31	3	27	26	40	30	X	22	25	35	22	0	25	29	40	28	28	
	20 FT	16	20	15	11	25	12	10	20	8	X	7	20	10	7	40	8	6	15	14	14	
	30 FT	10	10	6	6	5	8	5	7	3	X	3	10	6	3	5	2	6	8	7	7	
	40 FT	3	5	4	3	3	2	3	5	2	X	2	2	2	2	3	2	1	6	2	2	
50 FT	2	2	1	0	0	2	0	1	1	X	0	0	2	0	0	2	0	2	1	1		
											X											
DEPTH											X											
FSW											X	216	200	204	216	207	213	202	220	187	220	
TIME											X	19	25	16	16	15	16	17	18	17	20	
S.I.											X	6:07		16:34		16:47	2:01		4:21			
DOPPLER RATING 0-4 POST DIVE	15 MIN	0	0	0	0	0	0	0	0	0	X	0	0	0	0	0	0	0	0	0	0	0
	30 MIN	0	0	0	0	0	0	0	0	0	X	0	0	0	0	0	0	0	0	0	0	0
	60 MIN	0	0	0	0	0	0	0	0	0	X	0	0	0	0	0	0	0	0	0	0	0
	SYMPTOMS											X	0	0	0	0	0	0	0	0	0	0
												X										

Table II (Cont'd).

DIVE #		FIFTH										SIXTH										
DIVER	JT	LG	GP	JH	JH	JC	ES	DB	TP	SG	X	JT	LG	GP	JH	JH	JC	ES	DB	TP	SG	
STOPS	0 <sub>2</sub> at										X											
	10' FSW	0				4	5	0	0	0	X						0	15	15			
	10 FT	21				21	31	41	35	35	X						35	20	20			
	20 FT	11				10	12	18	12	12	X						12	6	6			
	30 FT	7				6	6	6	4	4	X						8	4	4			
	40 FT	3				2	2	2	1	1	X						2	1	1			
50 FT	0					2	0	0	1	1	X						2	0	0			
<hr/>																						
DEPTH											X											
FSW		198				204	196	210	215	220	X						231	239	231			
TIME		15				16	25	25	18	20	X						16	14	14			
S.I.		18:13				10:29		11:52		11:42	X						4:55		4:30			
DOPPLER							13:54		11:42		X							4:20				
RATING 0-4 POST DIVE	15 MIN	0				0	0	1	0	0	X						0	0	0			
	30 MIN	0				0	0	2+	0	0	X						0	0	0			
	60 MIN	0				0	0	0	0	0	X						0	0	0			
SYMPTOMS		0				0	0	0	0	0	X						0	0	0			

Nitrogen narcosis was not a significant problem for any diver. They were all able to find small objects in the wreck, shoot underwater video and find passageways in the wreck. No diver was lost in the wreck and all divers maintained a good level of orientation at depth. All the divers agreed that concentrating on the dive plan and sticking to the dive plan as closely as possible helped them prevent any serious symptoms of nitrogen narcosis. All the divers admitted to being "narced" to a small degree.

### Equipment

The equipment used by each diver was extensive, with multiple back-up pieces and systems. All divers had two large cylinders for compressed air, usually two 80 or 90 cubic foot tanks, often hooked together in a manifold system. Multiple regulators were connected to each tank with provisions for buddy breathing if necessary. Additionally, most divers attached a 40 cubic foot pony tank to the two larger tanks. The pony had a separate regulator. Spare air was carried by many of the divers as an added precautionary measure. All divers carried "up lines" with 250 to 500 pound air bags and 250 feet of line. All divers carried dual gage systems in addition to their dive computers. Many divers carried two dive computers and one carried three (in case the other two failed). All divers had multiple dive knives and several carried small tool kits containing wire cutters, pliers mallets and screwdrivers. Crowbars or metal pipes were carried to ward off large marine predators. Collection bags and air bags were also carried to send up the artifacts from the wreck. A few divers dived with cameras and lights. All divers except one wore dry suits and averaged 40 pounds on their weight belts. The total weight of the equipment was estimated to be in excess of 200 pounds per diver with an approximate value of \$5,000 per diver, not including camera equipment.

### Computers

Of the ten divers in this study, eight used computers to determine their stops on ascent. Two divers (S.G. and T.P.) used the guidelines of the U.S. Navy Dive Tables, asserting that they "could not have batteries die" on them at depth. Although many divers did not breath oxygen during their 10 foot stop early in the study, most divers were breathing some surface supplied oxygen by the middle of the study.

Dive computers were used by the majority of the divers, but only the Beuchat Aladin, Pro or Guide were used. The low rate of decompression sickness (0 cases) is significant when one considers the findings of McGough *et al.* (1990) and the Divers Alert Network (1989).

### Discussion

The low rate of bubbling and no decompression sickness in these divers may reflect their prior diving experience and the use of the dive computer. However, all the divers had prepared for the Andrea Doria dives by performing progressively deeper dives weeks to months before attempting dives this deep. Most divers started the season with dives to 130 fsw, progressing to dives of 170-190 fsw over the ensuing several weeks/months. None of the divers in this study made the Andrea Doria their first deep dive of the year.

All divers carried plenty of compressed air and had back-ups for all equipment in case of failure. All divers studied the charts of the Andrea Doria's interior and planned their dive and dived their plan from penetration to exit. This may have helped decrease the effects of nitrogen narcosis as they were able to concentrate on only a few tasks. However, nitrogen narcosis was never a significant problem.

The impaired performance of divers breathing compressed air at depths greater than 132 fsw is well documented (Schilling *et al.* 1984). In this study, dives were commonly breathing compressed air 7 to 8 ATA with minimal effect on performance. This result is far different from the findings of divers who attempted to dive the U.S.S. Squalus at a depth of 240 fsw. Those divers "reported having difficulty thinking clearly and one diver apparently "lost consciousness" (Schilling, *et al.*, 1984). According to Edmonds *et al.* (1984) " all divers breathing compressed air are significantly affected at a depth of 60 to 70 meters. Martini's law states "each 15 meters (50 feet) depth is equivalent to the intoxication of one martini".

None of the divers felt they were significantly affected by "rapture of the deep". All divers were able to stick to their tasks of finding relatively small artifacts, while maintaining their orientation and avoid running low on air. According to the divers, their persistent "sticking to the task" helped them avoid the severe effects of nitrogen narcosis.

### Summary

Ten divers of various ages, levels of fitness, diving experience and occupations performed repetitive dives to 200 fsw and deeper with compressed air over the three day period. Doppler testing revealed a very low rate of bubbling among the divers. There were no clinically identifiable cases of decompression sickness or air embolism. These findings would concur with those of Nishi, *et al.* ( 1981) who stated "the Doppler method provides a method of assessing divers as to their susceptibility to decompression sickness".

It is obvious that ten divers do not adequately represent an entire diving population; however, more research needs to be done to determine the true risks of deep diving for the sport diver.

### References

- Divers Alert Network. 1989. Report on 1988 Diving Accidents. DAN, Duke University Medical Center, Durham, NC.
- Dunford, R. 1990. Pers. comm.
- Edmonds, C., C. Lowry and J. Pennefather. 1984. Diving and Subaquatic Medicine. Diving Medical Center, Australia. p. 198-200.
- Martin, J.H. and G. Bennett. 1977. Pictorial History of Ships. Chartwell Books Inc, New Jersey, p. 111.
- McGough, E.K., D.A. Desautels and T.J. Gallagher. 1990. Dive computers and decompression sickness: A review of 83 cases. *J. Hyp. Med.* 5(3): 159-162.
- Nishi, R.Y. *et al.* 1981. Assessment of decompression profiles and divers by doppler ultrasonic monitoring. 7th Symposium on Underwater Physiology. pp 717-727.
- Schilling, C.W., C.B. Carlston and R.A. Mathias. 1984. *The Physician's Guide to Diving Medicine.* Plenum Press, New York, p. 128-129.
- Suarez, E. 1990. Pers. comm.

**Session III - Scientific Diving**  
Glen H. Egstrom, Moderator

I would like to point out that scientific diving within the United States and worldwide has become a more well-defined group. This is the fourth in a series of workshops that we have put together because the people in the scientific community are now recognizing, as a function of their missions, that these problems are not unique to us, but are also of great concern to the recreational community, commercial community, military and others. I do think it is important to recognize that the scientific diving community has some constraints that are somewhat different from the rest. We were able to demonstrate to the Occupational Safety and Health Administration, after a seven year, several million dollar effort, that the scientific diving community is not required to meet the same kinds of constraints that the commercial industry does, *i.e.*, we are able to choose when we will dive. However, the constraints of the missions that we find in the scientific diving community do, in fact, require multi-day, multi-level dives, which are perhaps more highly regulated than we would sometimes like to admit. If we have data collection programs aboard research vessels that require scientists to dive to a particular depth on a regular cycle over a period of time, this puts us into a heavily regulated program due to limited ship time and costs.

Several years ago, we ran into a problem at UCLA where we had two incidences of decompression sickness following circumstances where the people had been diving on a series of days on a repetitive schedule down to relatively shallow depths, and in those circumstances had the classic problems. Therefore, we had to put in a constraint. We made an arbitrary decision that you dive and take day number six off and that seemed to work.

One of the other things we would like to have the group think about is what are we going to be able to do with the folks that we have been hearing about on these deep dives that are, in fact, outside of the range of what we considered in the past? We keep hearing the term "technical diving" which frankly, I used as well, defined as this deeper repetitive diving as being something that requires a great deal of additional technical and logistical support, if it is going to be done safely. The term "technical diving" begins to creep into more and more of the conversations. Technical as opposed to some other kind of diving. Technical diving was described within the framework of scientific diving in the OSHA proceedings to some significant degree in time past. None of us seem to be able to remember exactly what it said, but it was not recreational in nature. Perhaps what we need to do is identify some constraints that we can put into practice where the people recognize the additional responsibility they have.



## OVERVIEW OF SCIENTIFIC DIVING PROGRAMS

*Woody C. Sutherland*  
Duke / UNC Oceanographic Consortium  
Duke University Marine Laboratory  
Beaufort, NORTH CAROLINA 28516-9721 U.S.A.

*Michael A. Lang*  
Smithsonian Institution  
Scientific Diving Officer  
OAS / Research, A&I 2201  
Washington, DC 20560 U.S.A.

### Introduction

To determine the extent of multi-day and repetitive diving by scientific divers, we surveyed diving officers from a representative sample of established scientific diving programs across the country (see Appendix 1 ). Results of the survey are purely subjective. Scientific divers are required to submit monthly dive log sheets. These logs contain data such as the location of the dive, the purpose of the dive, the composition of the dive team, the maximum depth of the dive and the bottom time. Many programs have progressed to a reporting scheme that includes the time of day the dive began and ended. From this, one could possibly retrieve data concerning repetitive diving. However, most of the data is still on sheets of paper and few programs have the time or money to enter it into a computerized database. We anticipate the day when all scientific divers will wear recording devices. Then, following a day of diving, or at the end of the mission, the data could be downloaded directly into a computer. This would yield a robust database, accessible for a variety of analyses.

Procedures which govern purely repetitive diving have long been in place. It is hoped that the results of this workshop will lend some insight into safety procedures dealing with multi-day and multi-day repetitive diving.

### Terminology

Multi-day diving indicates making at least one dive on a number of consecutive days. Repetitive diving represents those dives made within the repetitive schedule of the decompression planning device, *e.g.*, 12 hours for the U.S. Navy dive tables, or return to the original no-decompression limits of the dive computer.

### Results and Discussion

Both the frequency and duration of scientific multi-day repetitive diving series are governed by the sampling and/or observational requirements of the research project. These dive series were reported to be done with frequencies ranging from weekly to semi-annually (Fig. 1). Over one third of the programs reported such dive series occurring on a monthly basis. The majority of these series lasted from 4 to 6 days (Fig. 2), suggesting a full work-week of diving. The series of longer than 6 days were generally reported as associated with cruises on oceanographic research vessels.

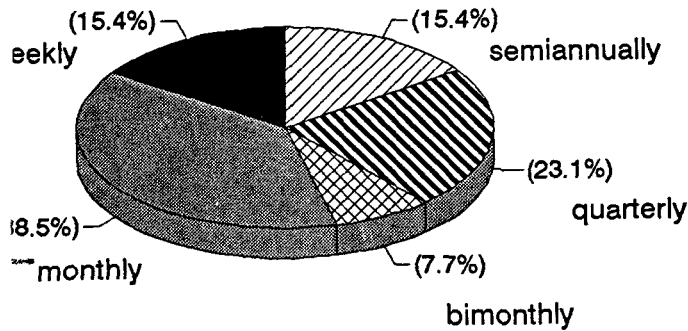

**Figure 1. Frequency of Multi-day Repetitive Diving Series**

The number of consecutive days of diving considered safe by the diving officers ranged fairly evenly between 3 and 7 days (Fig. 3). Four was the median number of days for all groups except the Mid Atlantic, which considered 7 days to be safe.

All programs had an average of 2 to 3 dives per day for multi-day series. A few diving officers reported instances of 4 to 5 dives per day for specific research projects.

All programs now either require or recommend a stop at 10 to 30 fsw for three to five minutes, following the guidelines of the AAUS Biomechanics of Safe Ascents Workshop. Far less than one percent of the scientific dives require strict decompression stops.

The survey respondents were divided into four groups based on the geographic location of the institution (Table 1). It is assumed that this is the region where the majority of diving occurs for the respective programs. A pattern in the frequency of multi-day repetitive dive series is suggested by this grouping. The Southern group appears to take advantage of its warm water, having a median number of 32 multi-day sessions per year per institution. The California group, exposed to rather consistently moderate water, reported a median of 12 multi-day series per year per institution. These are in comparison to a median of 4 multi-day series for the Northern and Mid Atlantic groups. However, no such pattern emerged for the duration of the multi-day series. All groups had a median duration of 4 to 6 days.

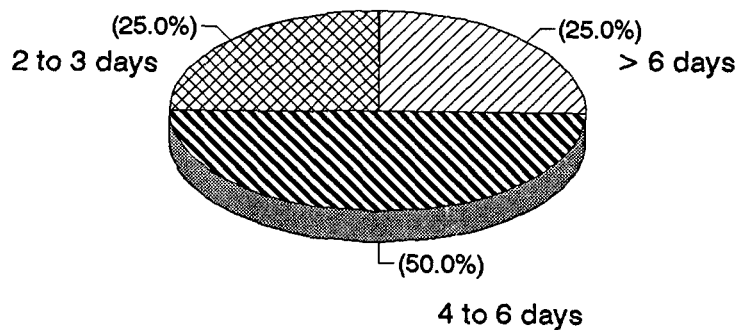

**Figure 2. Duration of Multi-day Repetitive Diving Series**

All programs reported using the U.S. Navy dive tables (however, at the time of the survey one program was in transition to the DCIEM dive tables), with the recommendation of decreasing the no-decompression limits by 5 minutes. Dive computers are widely used for multi-level, multi-day repetitive series. The surveyed dive programs had no special procedures regarding surface intervals for multi-day repetitive series, with the exception that some required a one-hour minimum between deep dives when a dive computer was used (as recommended by ORCA). In reality, though, few scientific dives are made using the minimum allowed surface interval since the divers have more tasks to perform than just switching air cylinders.

All programs reported having special considerations regarding multi-day repetitive diving included in their training of scientific divers. Diving physiology, with emphasis on fatigue and

hydration, is covered well in the certification and update classes. Periodic medical examinations of divers aid in ensuring their continued fitness for diving. Decompression theory, including the significance of slow ascent rates and stops, is also addressed. Special classes on dive computers are required for their use in most programs.

With no implication of cause and effect, diving officers were asked the number of probable cases of decompression sickness on record in their programs. These are historical numbers encompassing the life of the program, some of which have been in existence for over 30 years. Nine programs reported no cases of decompression sickness on file, four reported 1 case and 2 reported 2 cases.

The two programs having 2 cases of DCS (decompression sickness) anecdotally attributed them to multi-day repetitive diving. The first program had both cases occur within days on a research project requiring 2 to 3 dives per day for extended periods. That program has had no further cases reported after initiating a policy of no more than five consecutive days of diving. (The diving officer claims this limit was intuitively decided upon, but appears to be working.)

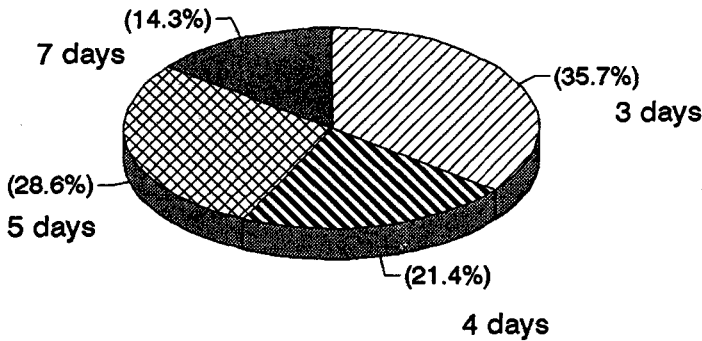

Figure 3. # Consecutive Days of Diving Considered Safe

Table 1. Respondent Geographical Grouping

Diving Program (Institution)	Location	Group
Univ. of Alaska	Fairbanks AL	Northern
Univ. of Washington	Seattle WA	Northern
Woods Hole Oceanographic Inst.	Woods Hole MA	Northern
Univ. of CA, Berkeley	Berkeley CA	California
Moss Landing Marine Labs	Moss Landing CA	California
Univ. of CA, Santa Cruz	Santa Cruz CA	California
Univ. of CA, Santa Barbara	Santa Barbara CA	California
Univ. of CA, Los Angeles	Los Angeles CA	California
Scripps Inst. of Oceanography	La Jolla CA	California
Smithsonian Institution	Washington D.C.	Mid Atlantic
Duke/UNC Oceanographic Cons.	Beaufort NC	Mid Atlantic
National Undersea Research Center	Wilmington NC	Mid Atlantic
Texas A & M Univ. Marine Lab	Galveston TX	Southern
Univ. of Miami	Miami FL	Southern
Univ. of Hawaii	Honolulu HI	Southern

The other program had both cases occur on a research project where scientists were making up to 7 dives per day of short duration with short surface intervals. The dive profiles for both cases were well within the U.S. Navy no-decompression limits. No further cases have been reported by this program since divers were urged to maintain slow ascent rates and make stops at 10 to 30 fsw. None of the programs which had one reported case of decompression sickness had any suggestion that multi-day repetitive diving may have been an issue.

Figure 4 depicts an overview of the survey results. The vertical scale has been cropped to decrease the exaggeration caused by the number of divers category. Most programs reaching the limit of the graph have more than 50 scientific divers.

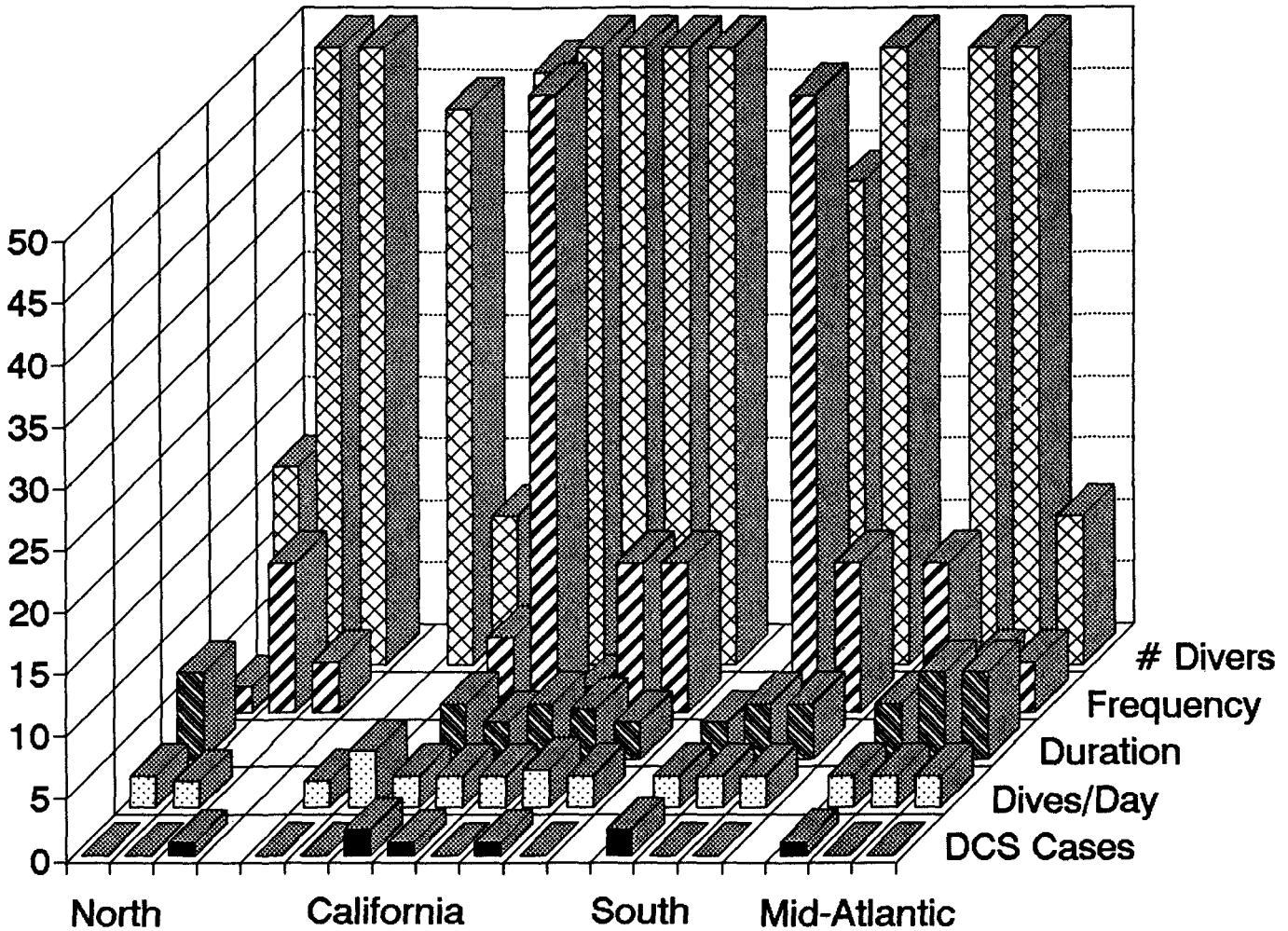

Figure 4. Survey Overview

### Summary

Scientific diving programs from California and the South tend to perform more multi-day repetitive diving series per year, and as suggested, this may be due to water temperature. The programs from the Mid Atlantic, either in practice or in consideration, dive for more consecutive days. The mildly sloping, sandy ocean bottom of the Mid Atlantic offers few attractive dive sites. Scientists from this region often work in other locales, and because of this travel, may extend their days of diving to get the most research for their time and money.

It may be hypothesized that the larger programs, having more divers, perform more multi-day repetitive series. There is no correlation between the size of the program, *i.e.*, number of divers, and the frequency of multi-day repetitive series, or between number of divers and duration of series. Also, there is no correlation between the number of divers and number of cases of decompression sickness. The

programs with one recorded case of decompression sickness were in the middle of the range of sizes, whereas those reporting two cases were at the smaller end.

The goal of every scientific diving program is to provide scientists a tool to aid in their research, *i.e.*, the ability to work underwater, while minimizing the hazards of working in an alien environment. We have presented a summary of the experiences of a representative sample of the scientific diving community in multi-day repetitive diving. We conclude with a list of topics that represents concerns expressed by those diving officers responding to the survey. It is anticipated that these will be addressed and possibly answered by this workshop:

- 1) Is there a limit to the number of dives that can be safely made per day?
- 2) For how many consecutive days may one dive?
- 3) What factor does water and/or air temperature have in multi-day repetitive diving?
- 4) Is the depth of diving of any significance?
- 5) Are presently-available dive computers sufficient for multi-day repetitive diving series?
- 6) What is the minimum safe time to fly after multi-day repetitive diving?
- 7) Can divers acclimate or adapt to such diving?
- 8) What are the specific hazards of repetitive yo-yo and bounce diving?

### Appendix 1.

#### REPETITIVE DIVING WORKSHOP SURVEY OF SCIENTIFIC DIVING PROGRAMS

Organization: \_\_\_\_\_

Responder: \_\_\_\_\_

1. How many divers in the program?
2. On average, how often are divers performing repetitive dives?  
annually, semiannually, quarterly, bimonthly, monthly, or weekly
3. How long do these series last?  
2 to 3 days, 4 to 6 days, more than 6 days
4. Typically, how many daily dives per series?  
2 to 3 per day, 4 to 5 per day, more than 5 per day
5. What are the average surface intervals?
6. What dive tables are used?
7. What dive computers are used?
8. What percentage of dives require decompression stops?
9. Are stops of 3 to 5 minutes at 10 to 30 fsw made on every dive?
10. Give symptoms from any cases of DCS:
11. Do you have an established database of scientific dives that could be shared with others?
12. What are the particular requirements or concerns of your program regarding repetitive diving?
13. a) Do your divers practice any of the following dive plans?  
multilevel, repet-up, multi-day, surface decompression  
b) What are your procedures for these?
14. How many consecutive days of diving to you consider to be safe?
15. Which of the following dive plans do you consider to be safe? How do you justify these opinions?  
multilevel, multi-day, yo-yo, surface decompression
16. Do you see the need for any special equipment or training considerations for repetitive and/or multi-day diving?
17. Are there any specific questions you would like to see addressed by the scientific diving panel at this workshop?

**A DATABASE OF OPEN WATER, COMPRESSED AIR, MULTI-DAY REPETITIVE DIVES  
TO DEPTHS BETWEEN 100 AND 190 FSW**

*Caroline E. Fife  
G. Wayne Pollard  
Giles Yancey Mebane  
Albert E. Boso  
Richard D. Vann*

Duke University  
F.G.Hall Hypo-Hyperbaric Laboratory  
Box 3823  
Durham, NORTH CAROLINA 27710 U.S.A.

University of Texas Health Science Center  
6431 Fannin, MSMB 5.020, Houston, TEXAS 77030 U.S.A.

*Evaluation of operational records can assist in the development of safe decompression procedures for deep multi-day repetitive air dives. From 1985 to 1989, 49 males and 13 females sponsored by the Institute of Nautical Archaeology (INA) performed 7,523 dives on compressed air scuba between 100 and 190 fsw. Each season divers made two 20 minute dives per day, 5-6 days per week, with a mean surface interval of 6 hours, for a cumulative bottom time of 2,507 hours. Three decompression profiles have been employed: (1) U.S.N. Standard Air Tables, modified with oxygen breathing (O<sub>2</sub>) at 20 and 10 fsw, 3,732 dives between 100-180 fsw (157 fsw mean); (2) statistically based schedules developed at the F.G. Hall Hyperbaric Center, with O<sub>2</sub> at 20 and 10 fsw, 1,835 dives between 100 and 170 (157 fsw mean); and (3) F.G. Hall schedule with all decompression at 20 fsw on O<sub>2</sub>, 1,956 dives between 110-182 fsw (mean 162 fsw). The incidence of decompression sickness by profile was: (1) 1 pain only (PO), 1 serious neurological (N) (.05%); (2) 1 PO, 0 N (.05%); and (3) 0 PO, 0 N. All incidents of DCS were treated satisfactorily in an on-site recompression chamber. The successful continuation of this underwater archaeological project suggests that the evolutionary development of decompression procedures for deep repetitive air diving, is possible with reasonable safety by statistical design, laboratory testing, and controlled operational use.*

### **Background**

Many underwater scientific projects require diving deeper than 140 feet of sea water (fsw). Since funding for scientific projects is usually limited and most scientific divers have experience only with self-contained underwater breathing apparatus (SCUBA), safe and economic alternatives to helium-oxygen diving systems are therefore necessary. In situations where deep compressed air diving is necessary, oxygen has been employed during decompression to speed inert gas elimination. Evaluation of operational records can assist in the development of safe decompression procedures for multi-day repetitive air dives employing oxygen decompression.

The Institute of Nautical Archaeology (INA), under the leadership of Dr. George Bass, has carried out meticulous underwater excavations along the coast of Turkey for nearly thirty years. In 1984, diving

began on the deepest of these projects, a Bronze Age shipwreck at a site off a rocky peninsula called Uluburun (Bass, 1987). The data presented here includes only dives made between 1985 and 1989 although the project is still ongoing.

INA is housed at Texas A & M University in College Station, Texas. The majority of divers are archaeology students and thus all diving is under the aegis of the University Dive Board at TAMU. Diving physicians have been recruited from various institutions, particularly Duke University's F.G. Hall Hypo-Hyperbaric Center. The dive schedules discussed below were developed at Duke University. The excavation operates on a limited budget, despite support from the National Geographic Society and private contributions through INA. Excavations are carried out with the full cooperation of the Turkish Ministry of Antiquities.

Although graphs are entitled "INA Database", they refer only to data obtained from the Uluburun project. A large volume of data from other INA excavation sites, approaching 50,000 dives, has not yet been reviewed for publication.

### Sites and Systems

The Uluburun site is approximately 75 yards off a barren cliff in southwestern Turkey. The ship came to rest on a steep rocky slope between 140 and 170 fsw. Wreckage is scattered over a 30 x 60 ft<sup>2</sup> area. Artifacts have been excavated to a maximum depth of 185 fsw, although the seabed continues down a gradual slope past 300 fsw.

A land-based camp houses the majority of divers who commute daily by dingy to the surface support vessel. The surface support vessel is a 52 ft steel hull, former U.S. Navy T-Boat equipped with compressors powered by 110 v and 220 v generators. A 42" double lock J & J recompression chamber is located below deck. It is equipped with overboard dump of exhaled gas but has no climate control system to allow for cooling the chamber. Oxygen (O<sub>2</sub>) is delivered four to five times per week via "H" cylinders which arrive by supply boat from the nearest port, Kaş, 10 miles to the southwest. The O<sub>2</sub> cylinders originate many miles inland and are brought by truck over coastal mountains twice a month.

All diving is performed with standard SCUBA equipment, each diver carrying twin 72 ft<sup>3</sup> steel tanks. Water temperature at bottom varies from approximately 60°F in June to 64°F in August. Surface currents can approach 1.5 knots. An inverted plexiglass air-filled dome or "phone booth" at 140 fsw allows divers to converse when necessary and serves as a reserve air supply. A counterweighted shot line extends from the ship to the "phone booth". Two metal buckets attached to the shot line, one at 10 fsw and the other at 20 fsw, function as the decompression stops. In-water oxygen is supplied via low pressure hose from oxygen cylinders on deck to four second stage SCUBA regulators suspended at 20 fsw. Upon reaching the decompression stop, divers switch to the O<sub>2</sub> regulators. After completing decompression, divers ascend to the surface breathing air from their own SCUBA. There are several air filled SCUBA cylinders with regulators strategically placed on the dive site to serve as emergency air sources in the event of equipment malfunction.

All divers have basic SCUBA certification through one of the national training agencies. Divers vary from recently certified novice divers to INA staff with more than 20 years diving experience and vary in age from 20 to 56 years.

Four relays of 2 to 4 divers make 2 dives per day, five to six days per week for the duration of the season. Team members or "buddies" must remain visible to one another on the site. Due to the fragility of the artifacts, divers usually remove fins upon reaching their work area. This has the distinct safety disadvantage of drastically decreasing the diver's mobility in the water should an emergency arise. No more than 4 divers may decompress at any one time, so relays are staggered to allow each group to

complete decompression before the next group ascends to the stop. There may be as many as 8 divers in the water at any time, 4 on the bottom and 4 in decompression.

Bottom times of twenty minutes per dive are controlled by the topside timekeeper who signals divers by an audible alarm two minutes before the end of the dive and again at the end of the dive. The final two minutes allow the divers to stow their instruments and retrieve fins before beginning ascent at the final signal.

Descent rates are rapid, most divers requiring less than one minute to reach the plastic dome at 140 fsw before proceeding to their work area. Ascent rates approximate 1.5 ft/sec and are made with the assistance of the shot line secured at the plastic dome.

At the beginning of each season, work areas are designated by the excavation director, Mr. Cemal Pulak, and depth measurements are made by several different calibrated depth gages. Individuals assigned to work in any specific area are assigned to an appropriate decompression schedule. A diver working at a known depth of 162 fsw will be assigned to a decompression schedule of 170 fsw. All designation of "depths" in the figures below specify only the decompression schedule employed. A diver on the 150 fsw schedule would therefore be diving between 140 and 149 fsw. A diver at 150 fsw would decompress on the 160 fsw schedule.

This underwater project is unique in that divers, often engaged in meticulous excavation, are assigned a specific area in which to work at a known depth where they usually remain for the duration of their dive. Five divers were monitored for 4 weeks with Suunto dive profile recorders and the results are depicted in Table 1. The working depth was known from depth of the assigned area. The digital recordings of approximately 48 dives per diver were analyzed and the depth range above and below the working depth was determined for each dive. The average range depicted is the average daily excursion in fsw from the work area. Subject DF, the site photographer, often ranged as much as 16 fsw above or below his assigned area in order to photograph artifacts. However, subjects NH and MH, usually engaged in fine chiseling, ranged an average of only 2 to 3 feet above or below their work site.

Table 1.

Subjects	Sex	Working Depth	Ave Range (fsw)
DF	M	156	± 16 fsw
NH	F	157	± 3 fsw
CP	F	151	± 6 fsw
MH	M	147	± 2 fsw
JH	M	146	± 4 fsw

## Data

### A. Activity

To date, 62 individuals have dived on the site (49 males - 79% and 13 females - 20%). A total of 7,523 dives were logged between 1985 and 1989. Table 2 illustrates the number of dives by month and year. The total number of dives rose from 701 in 1985 to 1,956 in 1989, in part due to the extension of the season into September in 1989. August is usually the most active month. These data are depicted graphically in Figure 1.

Table 3 illustrates the initial and repetitive dives made by decompression schedule. Dives less than 120 fsw represent orientation dives. The majority of working dives occur between 149 and 169 fsw, thus, as discussed above, the majority of dives will follow decompression schedules of 150 to 170 fsw. Dives made on the 190 fsw schedule were to a maximum depth of 185 fsw. While the majority of dives



made were initial dives, most first dives were followed by a repetitive dive. The average number of consecutive days of diving, including divers who missed dives due to illness, was 5 days.

**Table 2.**

**NUMBER OF DIVES BY MONTH / YEAR**

	June	July	August	September	Totals
1985	0	366	335	0	701
1986	342	606	575	0	1523
1987	0	718	790	0	1508
1988	247	770	818	0	1835
1989	286	673	870	127	1956
<b>Totals</b>	<b>875</b>	<b>3133</b>	<b>3388</b>	<b>127</b>	

**Table 3.**

**TOTAL DIVES MADE ON THE DIVE SITE BETWEEN 1985 - 1989 (7523 DIVES)**

Dive Schedule (fsw)	<120	120	130	140	150	160	170	180	190
First Dives (3902)	90	7	3	18	1251	1660	755	112	6
Repetitive Dives (3621)	79	7	0	17	1110	1564	733	107	4

**Table 4.**

**SURFACE INTERVALS (HOURS) BY DIVE SCHEDULES.**

Repetitive Dive Schedules (fsw)	<120	120	130	140	150	160	170	180	190
Minimum Surface Interval	3.80	6.00	0	5.00	5.00	4.75	4.75	5.12	5.68
Maximum Surface Interval	6.80	6.75	0	6.75	7.80	7.50	7.25	6.60	5.86
Mean Surface Interval	5.99	6.32	0	5.86	6.07	6.00	5.98	5.90	5.77

Mean Surface Interval for all repetitive dive schedules = 6.01 hours

**Table 5.**

**AVERAGE NUMBER OF DIVES / DIVER / YEAR**

Year	Total Dives by Males	Male Divers Involved	Avg # Dives per Male	Total Dives by Females	Female Divers Involved	Avg # Dives per Female	Avg # Dives / all Divers
1985	618	20	30.9	83	3	27.6	30.5
1986	1156	17	68.0	367	6	61.0	66.2
1987	1058	18	58.7	450	7	64.3	60.3
1988	1145	18	63.6	690	7	98.6	73.4
1989	1298	15	86.5	658	8	82.2	85.0

The average surface interval (SI) by dive schedule are illustrated in Table 4. All dives made to depths of less than 130 fsw were performed according to modified U.S. Navy tables, thus surface intervals could be as brief as 3.8 hours. The mean surface interval for dive schedules between 140 and 190 fsw varied between 5.77 and 6.07 hours. The F.G. Hall tables specify a minimum SI of 5 hours, and diving performed with modified U.S. Navy tables was calculated for a minimum SI of 5 hours. However, a minimum interval of 4.75 hours was recorded for at least one dive on both 160 and 170 fsw schedules. This suggests that despite the vigilance of the excavation director, the site physician and designated time-keeper, errors may still occur in the implementation of tables in the field.

The average number of dives per diver per year are depicted in Table 5. The average number of dives increased annually from 30.5 dives per diver in 1985 to 85 dives per diver in 1989. The total number of dives per season increased yearly as seen in Table 2. The average number of dives per diver for males slightly exceeded that for females in 1985, 1986 and 1989. This is graphically depicted in Figure 2.

Table 6 illustrates all dives by schedule according to sex. Male divers, 79% of the total, performed 70% of the dives. Females, 20% of the divers, performed 30% of the dives. Female divers performed between 38% and 50% of dives on schedules between 160 and 190. These proportions are depicted in Figure 3.

### B. Decompression Profiles

Decompression procedures following standard U.S. Navy air decompression tables have been reported to produce a 1.25% incidence of DCS (Berghage, 1980). However, due to various technical and funding limitations, an alternative to compressed air SCUBA was not feasible on this site. Since a 1% incidence among 2,500 and 3,000 dives could represent 25 to 30 cases of DCS per season, modifications were made in the use of the USN tables.

DIVES BY MONTH / YEAR

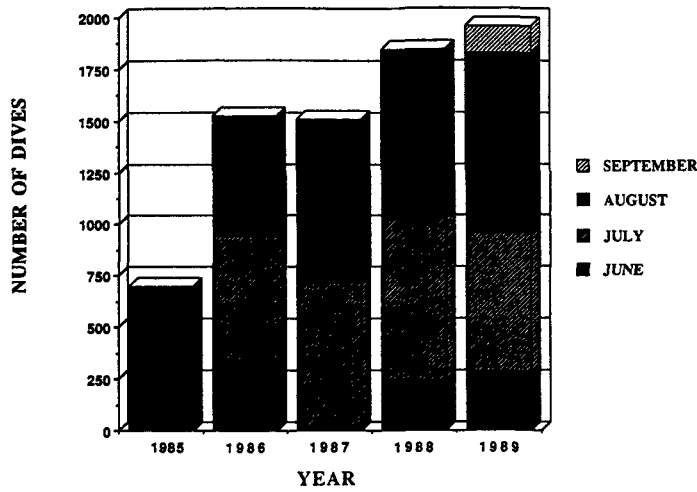

Figure 1.

AVERAGE NUMBER OF DIVES / DIVER / YEAR

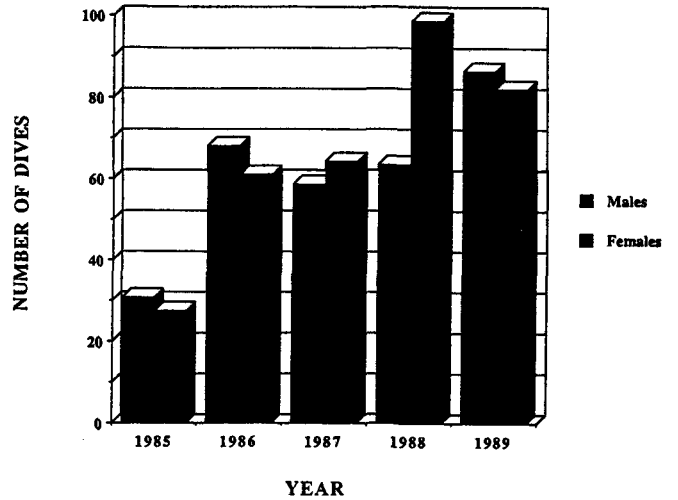

Figure 2.

NUMBER OF DIVES BY SEX

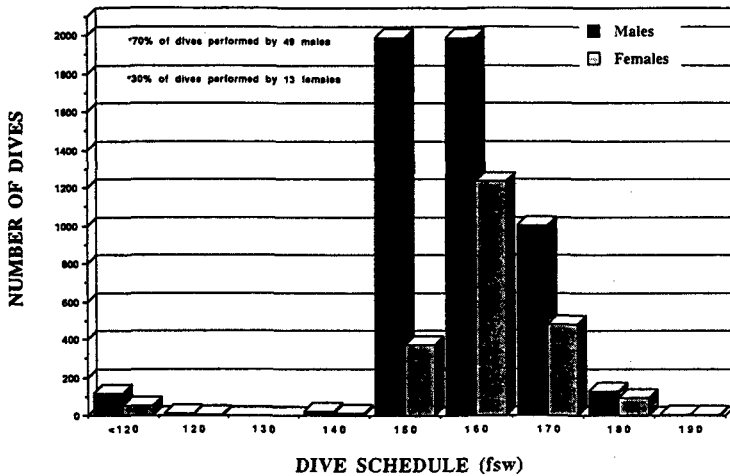

Figure 3.

DECOMPRESSION PROFILES

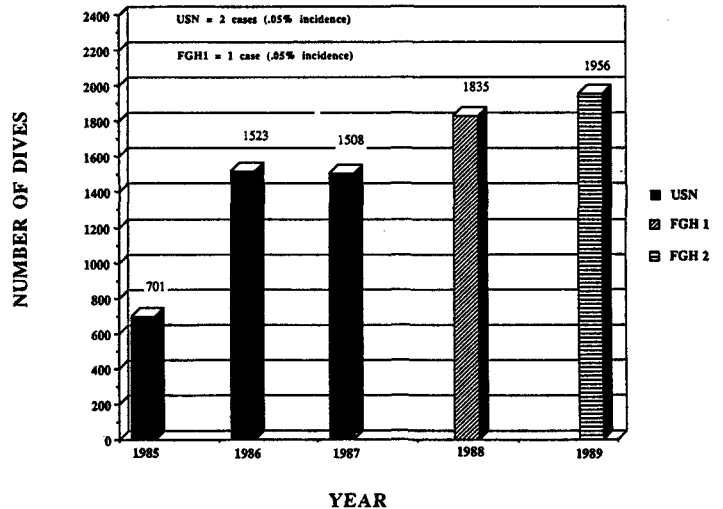

Figure 4.

Figure 4 depicts the number of dives made by decompression profile. From the 1985 season through the 1987 season, modified U.S. Navy profiles were employed. In 1985, U.S. Navy tables were modified by using in-water oxygen decompression at the 10 fsw stop only (Mebane). Decompression was carried out according to the time specified for air decompression. In addition, as is standard for most diving projects, the next deepest depth was chosen for the decompression profile. Individuals diving at 141 fsw decompressed according to 150 fsw profiles.

In 1985, there was one serious case of Type II DCS (see section below). As a result, in 1986 and 1987, U.S. Navy tables were employed with oxygen at both the 10 fsw and 20 fsw stop. No cases of DCS were reported in the 3,031 dives performed during those two seasons. However, the allowable bottom time

following USN tables was limited to 20 minutes in the morning and 16 minutes in the afternoon. In-water decompression times for the second dive exceeded 35 min in some dives. The mean decompression schedule for all dives employing USN decompression tables was 157 fsw.

Table 7.

INA Dive Profiles R. D. Vann

FIRST DIVE					SECOND DIVE			
Depth (fsw)	Time (min)	Gas	Est. Risk %	Surf. Int. (hrs.)	Depth (fsw)	Time (min)	Gas	Est. Risk %
150	20	AIR	<0.01	5	150	20	AIR	<0.01
20	15	O <sub>2</sub>			20	20	O <sub>2</sub>	
160	20	AIR	<0.01	5	160	20	AIR	<0.01
20	20	O <sub>2</sub>			20	25	O <sub>2</sub>	
170	20	AIR	<0.01	5	170	20	AIR	0.01
20	20	O <sub>2</sub>			20	25	O <sub>2</sub>	
180	20	AIR	<0.01	5	180	20	AIR	0.01
20	20	O <sub>2</sub>			20	30	O <sub>2</sub>	
190	20	AIR	<0.01	5	190	20	AIR	
30	5	AIR			30	5	AIR	
20	25	O <sub>2</sub>			20	35	O <sub>2</sub>	

Table 6.

TOTAL DIVES MADE ON THE DIVE SITE BETWEEN 1985 - 1989  
BY SEX.  
(7523 DIVES)

Dive Schedule (fsw)	<120	120	130	140	150	160	170	180	190
Male Divers (49) (5272 dives = 70%)	118	10	2	25	1991	1987	1006	128	5
Female Divers (13) (2248 dives = 30%)	51	4	1	10	370	1237	482	91	5

In 1988, simplified and abbreviated tables were employed according to profiles developed at Duke University's F.G. Hall Hypo- Hyperbaric Center (Vann, 1987). The experimental data which served as the database for these tables were the original dives from which current USN tables are derived. By statistical techniques which will be described tomorrow by Dr. Wayne Gerth, profiles which incorporated the effects of oxygen decompression were devised. By taking into consideration the more rapid elimination of nitrogen during oxygen decompression, total decompression time could be appropriately shortened. In 1988, more than 1,835 dives were performed with these tables, both daily dives having 20 minute bottom times. Two individuals were successfully treated for pain only (Type I) DCS on a U.S. Navy treatment Table 5 (see below). The mean decompression schedule for all dives performed in 1988 was 157 fsw. Decompression time was shortened approximately 10% over previous profiles providing a distinct safety advantage for open water decompression in rough water. Decompression profiles were also simplified, decreasing the possibility of diver error in timing decompression. Figure 5 depicts the F.G. Hall dive profile of repetitive air dives using oxygen decompression. The estimated DCS risk of these schedules was 0.01%. A minimum 5 hour surface interval was calculated for all depths.

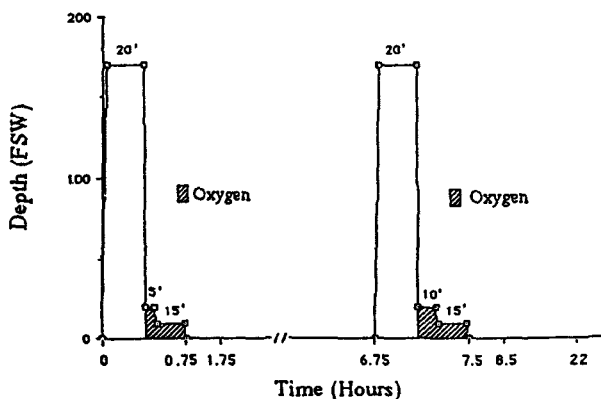

Figure 5.

In 1989, F.G. Hall profiles were further modified and simplified by omitting the 10 fsw stop. The time designated for the 10 fsw stop was added to time at the 20 fsw stop (ex: 5 min at 20 fsw, 15 min at 10 fsw was changed to 20 min at 20 fsw.) This has the advantages of (1) further simplifying diver-monitored decompression time, (2) decreasing the amount of wave action to which the divers were subjected during decompression and (3) facilitating nitrogen outgassing by the extended time at a higher inspired O<sub>2</sub> level. The predicted incidence of DCS was also 0.01% with these profiles. During 1989, 1,956 dives were performed according to the decompression profiles depicted in Table 7. There were no cases of DCS, although the mean

decompression schedule for all dives was 162 fsw, suggesting that diving in 1989 was slightly deeper than previous years. In fact, the 190 fsw schedule was first used in 1989. Note that there is a decompression stop at 30 fsw on air for the 190 fsw schedule.

**C. Decompression Sickness Cases**

Between 1985 and 1989, three cases of decompression sickness were diagnosed and treated with recompression therapy. The 10 male divers who made the highest number of dives on the site are depicted in Table 8. The first 6 subjects dived all four summers with the number of total dives ranging between 546 in the case of subject Pulak to 359 in the case of subject Pedersen. Subjects Rupert and Harun both experienced decompression sickness.

**Table 8.**

TOP TEN MALE DIVERS: SEASONS THEY DOVE: TOTAL DIVES MADE 1985 - 1989

NAME	1985	1986	1987	1988	1989	TOTAL DIVES
Pulak	yes	yes	yes	yes	yes	546
Tillev	yes	yes	yes	yes	yes	464
Piercy	yes	yes	yes	yes	yes	464
Turanli	yes	yes	yes	yes	yes	436
Frey	yes	yes	yes	yes	yes	418
Pedersen	yes	yes	yes	yes	yes	359
Neville	no	no	yes	yes	yes	327
Halpern	yes	no	yes	yes	yes	297
Yildiz	no	yes	yes	no	yes	294
Hall	no	no	no	yes	yes	215
*Rupert	*yes	no	no	no	no	23
*Harun	no	no	yes	yes	yes	62

\* = DCS victims

**Table 9.**

TOTAL NUMBER OF DIVES BY DCS VICTIMS

Dive Schedules (fsw)	<120	120	130	140	150	160	170	180	Totals
Rupert	2	0	0	0	21	0	0	0	23
					*DCS 1985				
Harun	2	1	1	1	30	6	21	0	62
					*DCS 1987				
Peachy	3	2	1	0	37	150	4	2	200
					*DCS 1988				

\*Year of DCS Case.

**Table 10.**

TOP EIGHT FEMALE DIVERS: SEASONS THEY DOVE: TOTAL DIVES MADE 1985 - 1989

NAME	1985	1986	1987	1988	1989	TOTAL DIVES
Hentschel	yes	yes	yes	yes	yes	485
Hirschfeld	no	yes	yes	yes	yes	468
Ray	no	no	yes	yes	no	288
*Peachy	no	no	no	*yes	yes	200
Fife	no	no	yes	yes	yes	197
Schroder	no	no	yes	yes	yes	188
Matthews	yes	yes	no	yes	yes	178
Lisa	no	yes	no	yes	no	52

\* = DCS victims

In 1985 subject Rupert, a 56 year old male, performed two orientation dives to depths less than 120 fsw as depicted on Table 9. He then performed 21 dives using modified U.S. Navy tables on a 150 ft. dive schedule (see Table 9). Following his last dive on August 3, he developed symptoms of Type II decompression sickness within minutes after surfacing. These symptoms were recorded as bilateral lower extremity weakness such that the subject was unable to walk without assistance, a marked decrease in sensation in the lower extremities and back pain. The dive which produced symptoms was the first dive after the "day off", during which time the subject had apparently made a lengthy mountain climb on a hot day and may have been dehydrated at the time of his dive. Some initial improvement was obtained after recompression on a U.S. Navy Table 6. The subject was treated twice aboard ship but apparently continues to have slight permanent residual neurologic deficit which primarily involves the loss of sensation on the bottoms of both feet. He did not resume diving on the site.

Subject Harun, a 23 year old male, performed a total of 62 dives on the site between 1987 and 1989. He suffered a case of DCS in 1987 using the modified U.S. Navy tables with oxygen at both 20 and 10 fsw. On August 1, 1987, approximately half-way through the season on his 3rd consecutive day of diving, he surfaced from a repetitive dive and complained of some mild left shoulder pain which completely resolved with compression on U.S. Navy Table 5. He returned to diving one week later and had no further difficulties for the rest of that season or the following seasons, despite the fact that he made a series of dives on a 170 fsw schedule after experiencing DCS on the 150 fsw schedule.

The 8 females who made the highest number of dives on the site between 1985 and 1989 are depicted in Table 10. Subject Henshel who participated in the excavation all five seasons completed a total of 485 dives. Subject Hirschfeld who dived for 4 seasons completed 468 dives; subject Peachy completed 200 in 2 seasons as compared with subjects Fife and Schroder who completed a lesser number of dives in three seasons. The total number of dives completed by Peachy for both seasons is depicted in Table 9.

On July 10, 1988 subject Peachy surfaced from a repetitive dive on her second consecutive day of diving complaining of right shoulder pain. She had performed approximately half of the dives for the season at the time symptoms developed. All dives had been performed on the first F.G. Hall profiles, the majority on the 150 fsw schedule. She was recompressed on U.S. Navy Table 5 within 1 hour and obtained complete relief of symptoms. She returned to diving after a one week hiatus and continued diving in the same work area on a 160 ft. schedule for the remainder of the season without further difficulty. The following season, in 1989, she experienced no difficulty although dives were made on schedules of 170 fsw and 180 fsw.

Table 11.

INA DATABASE  
BY SCHEDULE

DECOMPRESSION SCHEDULE	NUMBER OF DIVES	MEAN DEPTH FSW	NUMBER OF DCS	INCIDENCE
U.S.N. Air Tables (O <sub>2</sub> at 10 fsw)	3732	157	2	.05%
F.G.Hall Schedule #1 (O <sub>2</sub> at 20 and 10 fsw)	1835	157	1	.05%
F.G.Hall Schedule #2 (O <sub>2</sub> at 20 fsw/no 10 fsw stop)	1956	162	0	0%
TOTAL	7523		3	.03%

The low incidence of DCS despite deep, multi-day repetitive diving raised questions about the incidence of venous gas embolization (VGE) or "bubbling" among divers. In 1989, 5 divers, 3 males and 2 females, were observed daily by Doppler monitoring at precordial and subclavian sites for 4 weeks of repetitive diving. Serial observations were made according to DCIEM Doppler procedures at 10-30 min., 35-60 min. and 65-120 min. post-dive, and graded from I to IV by the Kisman-Masurel code. The working depths these divers obtained with Suunto monitors are depicted in Table 1. Approximately 240 dives were monitored. There were no cases of DCS. Three subjects, CP, MH and JH, attained a maximum bubble grade of II, one subject, NH, had a maximum of Grade II+; and one, DF, had a maximum of Grade IV. Subject DF demonstrated audible VGE after all dives; NH with a maximum of Grade II+ had bubbles after 70% of dives, and the remaining three subjects exhibited bubbles after only 12-16% of dives. There were no statistically significant trends in bubble grade from day 1 through 6 or from week 1 to week 4.

Monitoring was instituted mid-way through the season. Interestingly, maximum bubble grades showed a tendency to be lower after the second dive of the day ( $p > .10$ ). The data suggest that there is a wide spectrum of VGE response to this type of multi-day repetitive diving, and that frequent bubbling can be tolerated acutely. VGE in the 3 subjects with lowest bubble grades tended to occur in a random pattern in the small percentage of dives after which VGE were detected. One of these subjects, CP (Peachy), was

the individual who had suffered DCS the previous year. Despite his high and persistent bubble grade, DF (Frey), one of the most experienced divers (see Table 10), has never suffered DCS (Fife, 1990).

### Comments

The significance of operational factors such as nitrogen narcosis cannot be assessed by the data presented here. Significant problems with nitrogen narcosis appear to have been surmounted by orientation dives and a gradual increase in the depth schedules to which divers are exposed. It may also be assumed that individuals who do not tolerate narcosis well may be assigned to shallower areas of the excavation or may not be asked to return for the next season.

The data presented here is recorded by decompression schedule rather than by the exact depth to which divers are exposed. This data therefore may not accurately represent the actual depths of recorded dives. All open water dives involve some variation in dive exposures. The five individuals who were subjected to dive profile monitoring using the Suunto dive profile loggers represent only 8% of the total divers. The data suggests however that despite the fact that divers are assigned to specific work areas, some movement above and below the work area is unavoidable. The process of having divers decompress on the next deepest schedule may insure that appropriate decompression takes place. For instance, subject CP whose working depth is 151 fsw may range an average of 6 ft. deeper than her working depth on any given dive (See Table 1). She would nevertheless be required, by standard procedures, to decompress on a schedule designed for a 160 ft. dive, which should provide her with adequate decompression for that exposure. Subject DF, the photographer, was always required to decompress on the 180 fsw schedule because of his less structured movement on the site. Some divers however, may have a wider margin of safety relative to others depending upon the depth of their excursions and the chosen profile.

The length of decompression for each dive and the number of divers participating each day limits repetitive dives to no more than two a day. The "ideal" number of consecutive days of repetitive diving cannot be determined from this data. It is interesting to note that all reported cases of decompression sickness developed within the first three days of repetitive diving rather than on day 5 or 6. This may be affected by factors such as activity on the "day-off" period. One decompression sickness victim had engaged in vigorous mountain climbing on the day prior to resuming diving and this activity may have contributed to the severity of the symptoms which he developed. It is not clear whether acclimatization plays a role in the pattern of decompression sickness noted. All three cases were noted approximately mid-way through the diving season in July or early August. All divers are required to spend the initial week of each season performing dives which gradually increase in depth and in length of exposure. Divers who have missed more than 3 consecutive days of diving are required to perform at least one day of "warm-up" dives. For instance, they may be allowed to go back to their work area but are limited to half the usual bottom time. These "warm-up" or orientation dives may contribute to the process of adaptation if such a process indeed occurs.

The average number of dives per diver per year was similar for all 4 seasons although males exceeded females slightly in 1985, 1986 and 1989. While females represented only 20% of the divers they performed 30% of the total dives. Females performed between 48% and 50% of dives on deeper schedules. There was 1 case of decompression sickness in a female out of 2,248 dives by females for an overall incidence of .04%. There were 2 cases of decompression sickness in male divers out of 5,272 dives by males for an overall incidence of .03%. These data therefore do not suggest a significant difference in susceptibility to decompression sickness between males and females performing this type of compressed air diving but the number of afflicted divers is too small for statistical comparison.

It would appear that shallow in-water oxygen decompression, when performed in a controlled fashion, may have operational advantages for deep underwater air projects. If carefully controlled, in-water oxygen decompression may be a useful tool for underwater scientific projects. Furthermore,

statistically designed decompression schedules which are able to take into consideration the increased speed of nitrogen offgassing due to oxygen decompression may be very useful. Tables of this type designed for specific projects may have advantages over existing tables. Analysis of these operational records suggest that safe tables may be designed in this fashion.

Despite the low incidence of decompression sickness overall, it is apparent that the safe execution of schedules of this type require the presence of an immediately available recompression chamber. All cases of decompression sickness were treated in a timely fashion. Both cases of Type I decompression sickness resolved completely with a single recompression therapy. The seriousness of the Type II decompression sickness case underscores the need for the availability of appropriate medical care even if such episodes occur only once in several thousand dives.

The incidence of decompression sickness for the modified U.S. Navy Tables which included oxygen at either the 10 ft. stop or both the 10 ft. and 20 ft. stops was 2 cases of decompression sickness in 3,732 dives or .05%. The incidence of decompression sickness with the first F.G. Hall Schedule was 1 case of decompression sickness in 1,835 dives or .05%. For the second F.G. Hall Schedule with oxygen decompression at 20 ft. only, the incidence of decompression sickness was 0 in 1,956 dives. For the total 7,523 dives performed, 3 cases of decompression sickness represents an overall incidence of .03% (Table 11). Thus, the observed DCS incidence was reasonably close to the statistically predicted incidence of 0.01%. It may be concluded that despite the extreme depth of this compressed air project these dives have been completed with a minimum number of complications. Multi-day, repetitive deep air dives can be performed safely under controlled conditions.

#### References

- Bass, G. 1987. Bronze Age Legacy. *Nat. Geog.* 172(6): 689-702.
- Berghage, T.E. and D. Durman. 1980. U.S. Navy air recompression schedule risk analysis. *Nav. Med. Res. Inst.*, Bethesda, MD. January: 1- 22.
- Fife, C.E., R.D. Vann, G.Y. Mebane and R.D. Dunford. 1990. Doppler Surveillance of Open Water Multi-day Repetitive Diving. *Undersea Biomedical Research*. Vol.17 (Suppl.), Abstract.
- Mebane, G.Y. - personal communication.
- Vann, R.D. 1987. Likelihood analysis of decompression data using Haldane and bubble growth models. Ninth International Symposium on Underwater and Hyperbaric Physiology, UHMS, Bethesda, MD. pp: 165-181.

Scientific Diving Session Discussion  
Glen H. Egstrom, Moderator

- G. Egstrom: Regarding the divers that had decompression sickness, do you have any clue as to what they were doing prior to the time they got it? Were they dehydrated?
- C. Fife: Yes, there were risk factors in at least two of those cases. Rupert, who had the most serious injury, also happened to be the oldest diver. He had gone mountain climbing on the day off and was probably very dehydrated. It is not clear whether there is a risk factor as far as Peachy was concerned. She had not been ill recently. Neither had the other subject. We have since, in 1990, had one other case of decompression sickness in an individual who had been out with gastroenteritis for three days and he was bent on his first day of returning to dive and that probably also involved dehydration. Some of these kids work so hard on their day off, it might be that as our excavation director has suggested it might be safer if we don't give them any time off!
- P. Bennett: This is scientific diving; it is so different from recreational diving and these individuals are being very carefully monitored and controlled. We hear about other things such as oxygen in the water which in a sense DAN and the agencies resisted in recreational diving, but is now done because they see scientific divers doing it. When one starts to think about the kind of restrictions that are being applied in scientific diving, is this really the secret for safety? Is this actually making the tables safer, or is it the manipulation of the U.S. Navy tables and the Duke tables away from what we are accepting now in the recreational world and how can we match the two? How we can drive the two together for greater safety in recreational diving?
- C. Fife: The other thing I have been wondering about is if it has anything to do with the type of profiles and I am asking you a question because the kind of profiles that they are doing at the Institute of Nautical Archaeology are very unusually square profiles and their divers are returning to the same depth every day, working in the same area almost the entire summer and that is quite different from what the recreational divers are doing.
- P. Bennett: I understand, but, of course, the loading in the square dives is heavy. You expect nevertheless to have a lot of problems and you had a remarkable experience of safety.
- C. Fife: I wonder though if it has something to do with the fact that they always go to the same depth, like the caisson workers do?
- G. Egstrom: We have been hearing a lot of late again about pushing fluids. We always seem to want something that is going to help us prevent DCS and yet I do not hear any indications that there is any particular concern for diet or rest or hydration or anything else and yet you have a remarkably low incidence.
- C. Fife: We have a very controlled environment because everybody eats, bathes, sleeps and lives together in a very small area on this cliff. We talk about maintaining hydration but, in general, people eat three very square meals a day. We only have an hour of electricity, so you have to go to sleep when it is dark and you get up when the sun rises. And, if someone has been ill, our rule is that you cannot dive until your urine has no color. So, I think we have a very controlled living environment, as well. Alcoholic beverages are limited to one drink an evening ... at least as long as I'm awake!
- J. Bozanic: You mentioned that some of the people gathering your research data on site were on their first dives post-certification. Did you institute any kind of training program?
- C. Fife: Absolutely. That is what some of those dives of less than 120 feet were. We will sometimes spend the first week working them gradually into deeper depths.
- J. Bozanic: How many dives did that include?
- C. Fife: We have never had a fixed schedule of warm-up dives. We have always arranged it by how comfortable they seem in the water. If they are particularly comfortable in the water and they seem to have no problem progressing to deeper depths, then it may be over a week's time period



that they will actually be taken down on the wreck for a short dive, instead of the 20 minute bottom time and 10 minute dive and then they were assigned an area to work.

- J. Bozanic: You also mentioned that all the divers were using wet suits. Is there any reason that dry suits were not used?
- C. Fife: Money! All of our wet suits are donated. We have never been able to get anybody to donate dry suits.
- A. Galerne: Do you have any other female data? Do you have any special regulation for menstruation or pregnancy?
- C. Fife: Absolutely not. About half the women were on birth control pills. They all dive during their menstrual period and we have had no problems associated with that. The one female diver who did develop decompression sickness did so on the first day of her menstrual period, but I think that was just an anecdotal report. The females, although they made up only 20 percent of the divers, performed 38 to 50 percent of the dives on 160 through 190 feet schedules so they were very much overrepresented in the deeper depths.
- G. Egstrom: One of the things that you said sort of blows a little bit of a hole into the concept that maybe there is some adaptation going on because if you are having your hits half-way through the season, you would hope that they would be adapted by that time if there was any such profile that was going to emerge.
- G. Beyerstein: The sequelae that resulted from the decompression episode where the man never returned to diving, would you talk about what his symptoms were and what therapy he received?
- C. Fife: He had a bilateral low extremity paraparesis and he was unable to walk or ambulate without assistance after his symptoms developed. He became symptomatic after only about ten or fifteen minutes. This is all by historical records. I wasn't there. The problem is that he was a physician and apparently was claustrophobic. He was recompressed appropriately on a Table 6, but demanded to be taken out of the chamber before the end of the dive and I think refused some of the additional recompressions that were recommended and since he was the doctor, there was no one there to either sedate him or overrule him! So, I am not sure that he received optimal therapy. His limitation now is some sensation loss on the bottoms of his feet. He is, as of last week, apparently back to diving but not up to these depths.
- J. Stewart: The United States Antarctic Research Diving Program now has several thousand dives logged at roughly 28.6 degrees Fahrenheit and we have not had a case of decompression sickness yet.
- J. Bozanic: Last year, the program conducted 611 dives. Of those, approximately 550 were research dives and the remainder commercial or extension dives. We had no incidence or any problems in that temperature. Everybody was using dry suits.
- C. Piantadosi: The Turkish dive series raises the issue about oxygen use. Of course, there are a number of reasons to use oxygen theoretically, but I wonder if this is something that we ought to be looking at more extensively before recommending it to everybody. I wonder what advantage in-water use of oxygen has over the use of oxygen immediately upon surfacing or during the surface interval. Certainly, logistically, the latter would be more satisfying.
- C. Fife: We even discussed the idea of using both or surface interval oxygen and the tables, of course, were calculated with breathing oxygen at a higher partial pressure than one atmosphere and therefore we would assume it would have some advantages in terms of the speed of off-gassing due to breathing hyperbaric oxygen. But, I certainly do not know what would have happened if we had not been employing it. I am sure that we could devise tables that would not require it. I would have to let Dick Vann and Wayne Gerth address the length of decompression time that might be necessary if alterations of that nature were made and surface oxygen was used instead.
- C. Piantadosi: Theoretically, it will make a difference, but in practice, I'm not sure. Number two, you are dealing with in-the-water oxygen breathing pressure and although you have shown you can do

- it safely under those circumstances, if this becomes more widespread, we are likely to have in-the-water oxygen seizures.
- C. Fife: Somebody is going to have a seizure, you can bet on it.
- C. Piantadosi: So, I raise it both from a point of view of safety from decompression but also from the point of view of potential oxygen toxicity.
- G. Egstrom: Yes, we obviously have a potential problem.
- R. Vann: There is always the potential for CNS oxygen toxicity to develop when 100% oxygen is breathed underwater. This potential depends upon both depth and time of exposure. The shallowest, and shortest exposure on which convulsions have occurred was 25 fsw for 72 minutes during tests with working divers at NEDU. In a carefully supervised and controlled project where the depth of oxygen breathing does not exceed 20 fsw and the diver is at rest in calm water, the risk of oxygen toxicity is small for durations of up to 30 minutes. Indeed, oxygen diving at depths of 10-25 fsw for several hours daily for up to five consecutive days is a common occurrence for combat swimmers in many Navy's of the world. The risk of oxygen convulsions can be avoided completely, moreover, while some of the benefits of oxygen are achieved by breathing oxygen in the surface intervals between repetitive dives.
- C. Fife: Of course, if somebody decides to have a seizure with a regulator in their mouth, I would not call that well controlled under any circumstances, so it is a valid worry.
- P. Bennett: I just want to emphasize that DAN and I, speaking for the recreational diving organizations, do not go along with it. Although this is scientific diving, I do not want anybody reading this document when it is published, and thinking that recreational divers can now do this, which they should not. We do not like them doing it because recreational diving is uncontrolled and it is going to be brought a little bit to the level now of hanging in-water oxygen tanks. We know that someone is going to start at 25 and 20 feet, so why not 25 and then 30, and it will just be opening the envelope continually. And, this kind of material, as long as we discuss it within the framework of scientific diving is alright, but do not let us have people understand that it is for everybody.
- G. Egstrom: Panelists, within your experience and your programs, have you seen anything that would indicate that we have some hard evidence of adaptation? I have been lecturing on Environmental Physiology relating to performance for about 15 years. One of the things that stands out very clear in the literature is that there is a progressive adaptation, essentially exponential, that is usually well completed by the end of somewhere between three and four weeks. Now, if that were going to be the case, it would seem to me we would expect within this environmental change to see more in the way of adaptation.
- W. Sutherland: I have not had any experience with any DCS hits. It is hard to say if I have had any experience with adaptation. I do not have any answer to that. I do have the question if adaptation is happening, then maybe we should instigate some sort of training or check-out procedure, like Dr. Fife used in Turkey, where if we have scientists that are going to start a series of seven days straight of two or three dives per day, then maybe for a number of days prior to that, or a number of weeks prior to that, we should get them in the water.
- G. Egstrom: Do we have any history of either benefits or circumstances where this would be belied?
- W. Sutherland: Not to my knowledge.
- J. Stewart: I can only go back to the fact that at Scripps Institution of Oceanography we have about 200,000 logged dives now in depths from 270 feet to very shallow and many of them, of course, repetitive. We have had one case of decompression sickness and that occurred to a person who was diving day after day after day, who should have been really acclimated to the whole thing. So, I do not really think that is statistically significant in any respect.
- D. Kesling: From a physiological standpoint, I cannot really comment on adaptation. But, I do find in terms in diving competency and execution of the dive that there is some adaptation or some learning curve that occurs and this may be important in terms of the diver's safety and occurrence of problems following the tables. Of importance is the development of more competent divers and the execution of the dive, being able to follow the dive plans and being familiar with the work that is involved in the diving task.

- D. Harper: All the dives that we did in the past have been single day separated by maybe a day or two before the next set of dives. There was no opportunity for acclimation, so my answer to that is I have no information on it.
- C. Fife: How long are you finding that it takes to lose this acclimatization?
- G. Egstrom: It is interesting, based on a number of different environmental changes - pressure, temperature, others - it appears that you lose it just about as fast as you gain it. So, if you have got a two to three or four week layoff, you would expect that you would probably have to start over.
- C. Fife: I do find it very interesting in terms of the acclimatization that we do not seem to see our decompression sickness cases cluster on the fifth and sixth day of diving. Even though in at least one case there was a precipitating factor, I cannot think of any other two. I do not know if it has to do with the rigorous activity on their day off, but it seems that we would have seen clustering later in the week. I cannot understand why it is happening in the middle of a season, unless one of the things we have not done with the data is look to see the trend at the way the schedules increase as the season goes along because, in general, the dives start off in 140-150 foot range and then gradually increase. But, for the last two or three seasons that I have been there, there has been diving on the 180 and 170 foot schedules almost from the first week that divers reach the wreck. So, I do not necessarily think that it has anything to do with the way that we work over that three month period and I cannot account for it.
- D. Harper: I would like to comment on several points that Woody brought up. The number one question was bounce dives or yo-yo dives or spike dives, whatever you want to call them. The main project that I wanted to talk about involves almost all bounce diving. We ran a project from 1977 through 1984 where we were trying to take environmental snapshots. The Department of Energy was putting brine out from one of the strategic petroleum reserve sites and we were trying to find out what was happening on a given day. We had 28 stations to sample. It was raised to about 35 towards the end of the project. We were making spike dives. We could not anchor the boat, the stations were too close together at most points. We would jump overboard, being dragged to the bottom by the anchor. Three samples were then taken with the Neckman grab and the lift bag inflated to send the array back up to the surface. The divers then followed the lift bag up slowly. The average dive time for all dives was 4.9 minutes per dive. We did institute a safety factor by using underwater time (surface to surface), not bottom time. The typical dive profile toward the end of the project was four dives to 70 feet for five minutes underwater time, a surface interval of about three hours and then anywhere from two and sometimes three dives to 50 feet. This was all in one day, for one diver. The range of experience on this was from people who had several hundred dives to brand new divers who had just been certified by national training agencies. The range in ability of these people was similar to what Brett talked about. We had all ranges of physical ability. We had one girl who was so fat that we had to tie a line around her tank valve and her BC and lift her back on the boat with a cat-head. She could not get back up on the ladder. The two cases of DCS that Woody was talking about occurred in our project and this is where things get really peculiar as far as I am concerned. The two cases of DCS occurred in 1982, toward the middle of the project. They occurred in two consecutive months - October and November. The two cases were both at the same site, the eighth cervical nerve, resulting in localized paresthesia of the right forearm. They were both treated at the Hyperbaric Chamber in Galveston and they were both the biggest guys on the project, both of them were very experienced. So, the inexperienced divers had no problem, but the guys who had lots of experience and who also happened to be fairly large, were the ones that had the problems. And, so we come back to is bounce diving safe? In my own personal experience, yes. But, perhaps not for some other people.
- G. Egstrom: I think it is interesting and believe it was one of Haldane's early observations that the longer the circulation time, the more prone his experimental animals were to decompression sickness - the goat more than the mouse and the man more than the goat. I have sort of taken that to heart.
- D. Harper: One last comment, too, please. Both cases of DCS were well within the tables and well within all the dive computers that we ran these profiles through.

- R. Vann: Let me ask the panel what they consider to be an acceptable risk or incidence of decompression sickness? Should it be zero? Is any risk tolerable? We all seem, both recreational and scientific, to be somewhere on the order of three-hundredths of a percent or less. Is this too high?
- J. Stewart: I have been thinking we want zero incidence.
- W. Sutherland: Among the scientists, we are looking for a zero incidence. And, that is evident in the fact that when something does happen, usually we are changing our procedures and operations to eliminate that problem.
- C. Fife: In Turkey, we would like to have a zero incidence. You do not want to end up in a local hospital.
- G. Egstrom: I think the question was not what we would like to have, but what do we accept, if I heard it correctly because that is an interesting one. I mean, I would hope that we are all still aware that we probably are not going to duck the stray bullet!
- P. Bennett: The difficulty, in the number of recreational divers, there are probably more out there than the 600 we are seeing. These are DAN numbers after all. Of those, some are going to come into lawsuits. Some of the diver associations are heavily involved in trying to protect their instructors, so, yes, it needs to be lower. It is too high and is causing problems. Although we say that diving is safe compared to other sports - hang gliding, you name them - it is, but we would still like to get it safer.
- R. Hamilton: Some of us in this room pretend to be scientists. To a scientist, one or two data points is generally considered not much information. Let us not forget that. Let us not try to make big conclusions on the fact that the dives were not clustered on Friday afternoon or whatever when you only have three data points to begin with. Really, this is an important issue regarding the number of dives or the incidence of decompression sickness that we can accept. There are going to be occasional cases no matter what we do. One of the cases that Caroline reported was a 15 minute dive. The cases Woody reported were within the tables and, Don just mentioned the same thing. So, we have to be prepared to accept it. We should be prepared to deal with it and we should carry on. We do strive to reduce it as low as it can possibly be, but we should not consider that it can ever be totally zero.
- J. Bozanic: The question was one of what risk is acceptable and zero is what we are striving for within the recreational community, at least at NAUI. However, there has been some discussion recently with what to tell students because our purpose is education and training and telling them that diving is a safe sport. That there is zero chance of accident obviously is not realistic given the numbers of people that are out diving and get sporadic hits. We are currently trying to quantify some level of acceptable decompression sickness that we can inform the students of from that standpoint, primarily by comparing it with other active sports.
- C. Fife: An incidence between 0.01 and 0.03 percent gives us about one hit a season, which is about the most that we would like to have to deal with in this remote area.
- J. Lewis: I don't know how to answer the issue of what is an acceptable incidence. Obviously, if you are the incidence, it is not very acceptable. But, to put it in perspective, I have heard several numbers today and they have ranged all over the place, but kind of one out of 10,000 seems to be maybe an average or typical and it occurred to me that if you dived for 50 years and 200 dives a year, that's 10,000 dives. And, it seems to me that that is an interesting number to reference.
- J. Stewart: As I indicated, we have about 200,000 with one incidence, but again, I would like to see zero.
- M. Hahn: As far as I see the risks of DCS, it cannot be looked upon as isolated from the other risks of diving. We, in Germany, found that the risks of AGE from lung over-pressure accidents is by far exceeding the risk of DCS. Panic ascents are considered the most dangerous events in diving and not DCS because I told you many dives are performed in dark, muddy and cold waters so the limit of panic is coming rather close to what is felt usually. We have 16 years of data covering about 300,000 insurance years, with not even one case of a fatal DCS. We had a lot of cases of death and severe therapy resistant cases of AGE from lung over-pressure.

- G. Egstrom: I certainly appreciate that comment. The difficulty here though is we are talking about primarily trying to focus on multi-day, multi-level problems and they would appear not to be related to lung over-pressure. We all agree that AGE is a serious problem and, as a matter of fact, one of the reasons why we are urging this safety stop at 10 to 30 feet for 3 to 5 minutes is to combat that tendency for the individual to fly through the water and protrude waist high above the surface.
- L. Blumberg: I am a sports medicine physician and I can give you some statistics on other athletic endeavors that people participate in. If you ski 166 days in your lifetime, you will have a serious injury - that is the average. If you play football, you will have one injury per game. In other words, if there are 40 players playing, there will be one serious injury per game. If you play soccer, you will have one serious injury per two games, every soccer team having 15 players. Relatively speaking, diving is a very safe sport. I do not know whether it is because you have to be certified to dive, or whether we are getting smarter and the diving equipment is better, but relatively speaking in terms of recreational activity, diving is still a very safe sport. It is wonderful that we are trying to make it safer, but I do not think we are doing poorly right now.

**Session IV - Commercial Diving**  
**André Galerne, Moderator**

We take advantage of this session to give you some statistics about the commercial diving industry. We were encouraged when we heard about this AAUS workshop because we told you what has happened in Europe where the Government has more or less forbidden, or at least very strongly limited, the repetitive dive or the surface decompression technique. Ninety percent of the diving done in the Gulf of Mexico is done using that technique. Nothing can be changed in this field without great consequences on the financial result of the cost of the diving for all, particularly the Gulf of Mexico.

American Association of Diving Contractors (ADC) is trying to prepare a book on diving including tables which will become the bible of the diving industry. We would like to try to succeed and we will certainly talk to AAUS and UHMS to succeed in having a regulation which would encompass not only the offshore diving, but also the inshore diving and the nuclear diving. All that is on the project board now and our firm has been very active in this particular case. It is interesting to see how the diving industry is interested in suppressing the diving accidents. We are not talking about occupational peril and damages which are much, much higher than the figures we receive now because in a lot of the bends, there is no residual trace. This was not true in the beginning of the century when the toolbox of every diver already had a catheter to enable passing of fluids, considered as a normal problem for the divers. So, fortunately, we have seriously improved.

Jean-Pierre Imbert started his diving career with a group in France called Le GERS (Groupe d' Etudes et de Recherche Sousmarine), which was started by Commandant Cousteau a long time ago. Le GERS has been the pioneer of diving in Europe and in France in particular, and has done a lot of research directly involving deep diving. Jean -Pierre has been working with the COMEX deep diving program since 1975 and is now the Diving and Safety Manager for COMEX Services.

Jack Reedy has been in the military diving sector for 20 years . He has been an aquanaut in the Sea Lab Program and has done two tours of duty with the U.S. Navy Experimental Diving Unit. He is one of the authors of the U.S. Navy Unlimited Duration Excursion Tables. Jack has fourteen years of commercial diving experience in the Gulf of Mexico with experience in the North Sea, Canada and California. He worked as a diving supervisor, saturation superintendent and diving safety and training officer. Currently, he is the Safety Officer of Cal Dive International.

Gary Beyerstein is the Safety and Medical Liaison Manager for SubSea International and has held that position for the last five years of his 16 years with SubSea. Since leaving the field in 1980 to enter management, initially as Domestic Operations Manager, he has continuously been responsible for SubSea's Diving and Hyperbaric Incident Management. Over the course of that time, he has constantly interacted with SubSea's corporate Medical Director, Dr. Chris Lambertsen. Gary is a co-author of SubSea's Medical Manual, incorporating a unified therapy set of treatment protocols which were offered as a poster presentation at the June 1988 UHMS meeting. He is a Diver Medic and an active participant with the ADC National Safety, Medical & Education Committee. Gary has dived to 1,010 feet and has accumulated more than 9,000 hours of saturation diving exposure. He has suffered the chokes and, on another occasion, paralysis from the waist down, both episodes successfully treated. One of his major interests has been the prevention and treatment of DCS.

Bud Mills is a CSP, the Safety Medical Director for American Oilfield Divers. He has been for 21 years with the U.S. Navy as a Hospital Corpsman Diver; 15 years in the commercial diving industry as a diver, supervisor and superintendent. He belongs to the American Society of Safety Engineers, the Undersea and Hyperbaric Medical Society and the ADC Safety, Medical and Education Committee.

Bob Merriman is with Global Divers and Contractors, Inc. He has 20 years of military diving experience. Bob retired as a Master Saturation Diver from the Experimental Diving Unit in Panama

City, Florida. Bob worked in the commercial diving field since 1976, primarily involved in the management of mixed gas and saturation diving.

Terry Overland is with Oceaneering International and is responsible for the safety of Oceaneering personnel in North, South and Central America, including ROV inspection, vessels and engineering and administrative staff at eleven locations. He has been working for Oceaneering for the last 16 years, starting as a Tender and working up to Diving Supervisor. He has held the position of American Region Safety Officer for the last eight years. Terry has been trained as a Diver Medic, is a board member of the National Board of Diving and Hyperbaric Medical Technology, an associate member of the Undersea Hyperbaric & Medical Society, a member of the Gulf Coast Safety and Training Group and, a member of ADC Safety, Medical and Education Subcommittee.

John Hazelbaker is the only representative here of the in-shore diving industry. He became a sport diver in 1959 and started his own company in 1969 and has been working as a freelance commercial diver. His duties now as President include corporate management and diving on deep air, deep penetration and technically demanding jobs. John has logged over 11,000 hours working time underwater on numerous pipeline, salvage and specialized marine construction projects. He currently serves on the Board of Directors of the Association of Diving Contractors, is the Chairman of the ADC Midwest Chapter and, Chairman of the ADC National Committee on Underwater Bridge Inspection Standards.

## SHORT AND REPETITIVE DECOMPRESSIONS IN AIR DIVING PROCEDURES: THE COMMERCIAL DIVING EXPERIENCE

*J.P. Imbert*  
*X. Fructus*  
*S. Montbarbon*  
COMEX Services  
36 Bd. des Oceans  
13009 Marseille Cedex 2, FRANCE

*Commercial diving uses a wide variety of procedures, some of which can be questioned on the basis of the pressure changes they introduce. Models were used to analyze data from the Comex data base on yo-yo diving, surface decompression diving, repetitive diving and split-level diving. It was found that the arterial bubble model provides a simple explanation for the occurrence of Type II decompression sickness in yo-yo diving and surface decompression diving. This result shows the limit of the U.K. Department of Energy approach in restricting in-water decompression exposures in the North Sea U.K. sector.*

### Introduction

Offshore commercial diving relies on air diving for shallow operations. During the past 10 years, its importance has significantly increased due to the development of inspection and maintenance programs on platforms. However, the limits of air diving remain those of bounce diving: short bottom times and safety of decompression.

To cope with these limits, the diving contractors have developed a variety of procedures. Their diving manuals propose a range of basic diving procedures such as in-water decompression, surface decompression (sur-D) or transfer under pressure (TUP) and offer the possibilities to combine them with oxygen stops, repetitive diving, split-level diving or nitrox diving for operational flexibility.

The resulting safety performances can be estimated from the information compiled by T. Shields (Giles, 1989) for the U.K. Department of Energy (DOE) in a survey of air diving operations in the North Sea U.K. sector (this report will be later referenced as the DOE report). Examining exposures of 1988, 17,044 dives were recorded which lead to 6 Type I cases and 11 Type II cases, corresponding to an overall decompression sickness (DCS) incidence of 0.10%.

This paper proposes to further investigate the safety performances of special air diving procedures using the Comex diving reports data base (Imbert and Montbarbon, 1990).

### Selecting a Model for Data Analysis

We selected two models for analysis to help clarify the data. The first one will be called the tissue gas load model. Analysis of these DOE report data was conducted by Shields using pressure versus time diagrams. It must be noted that plotting DCS in pressure versus time diagrams implicitly refers to a relationship between DCS occurrences and tissue gas loads. In a first approximation, the tissue gas load depends on the depth and the bottom time of the dive.



Shields used these diagrams to draw a limiting line separating safe and unsafe exposures assuming that:

- DCS is related to tissue gas load at the end of the bottom phase;
- therefore there must be a tissue gas load threshold that induces DCS;
- since tissue gas load is a function of depth and time;
- hence depth and time limitations will be the way to safer diving.

This rationale was the basis of the DOE Safety Memorandums (DSM) restricting the air diving exposures in the U.K. sector. These DSM initially concerned surface decompressions (U.K. DSM, 1986) but later extended to in-water decompressions (U.K. DSM, 1988). Such limitations for in-water or TUP decompressions were questioned at the 1990 EUBS Workshop on operational dives data bases (Imbert and Montbarbon, 1990).

The tissue gas load model provides a reasonable explanation for tissue bubble formation. It is accepted that bubbles in the connecting tissues of the articulations may induce pain-only DCS. The tissue gas load can be easily modeled and is the basis of decompression table calculation. However, the use of the tissue gas load model for the prediction of Type II DCS is subject to controversy.

One alternative approach is the arterial bubble model or critical diameter model (James, 1982; Hills and James, 1982). This model considers gas bubbles initially trapped in the lung filter during normal decompression. Following a recompression, they may pass the lung and be dumped into the arterial bed, reaching a neurological tissue and causing a Type II DCS. Another scenario considers that a rapid ascent to the surface may generate bubbles of a diameter small enough to cross the lung (Hennessy, 1989). This model raises three points:

- DCS should not be treated as a whole. Type I and Type II DCS should be studied separately because their mechanism differs.
- Current decompression tables might only cover the Type I DCS risk: the models they use cannot predict Type II DCS occurrence.
- Some diving procedures should be questioned: the recompression they introduce might facilitate the transfer of bubbles through the lung.

The concern is whether a higher risk of Type II DCS exists with diving procedures involving short and/or repetitive recompressions such as:

- "Yo-yo diving", which applies to the case of shallow diving associated with frequent returns of the diver to the surface to pick up tools or equipment.
- Surface decompression where the divers rapidly ascend to the surface prior to recompression in a deck chamber for the rest of their decompression need.
- Split-level diving which is used in inspection works and permits the divers to operate at various depths on jacket nodes.
- Repetitive diving when the divers perform a second dive with a surface interval of less than 12 hours.

### **The Comex Air Diving Procedures**

Comex has developed a strong company culture under the influence of Dr. X. Fructus and has always used original decompression procedures.

#### **The 1974 Comex air tables.**

The first Comex air decompression tables were computed in 1972 and validated during onshore trials by Dr. X. Fructus and C. Agarate. The final version of the tables for in-water decompressions became the French official air tables in 1974.

These tables were computed using a classical "Workman model" based on 12 tissue half-times and M-values (Workman, 1965). The model was further complicated as DCS occurred during the trials and modifications were introduced: the tissue half times were altered during the ascent and some of the M-values became a second degree function of the ambient pressure. The final model (unpublished) has some interesting features.

Repetitive tables assumed the worst possible case for the computation of the second decompression. The 12 tissue residual nitrogen contents were supposed to be equal to their M-values at the end of the first dive. Of course, this is never the case, but the assumption allows the computation of a repetitive table without having to consider the characteristics of the previous dive. The advantage was that the 1974 Comex repetitive tables were printed for each surface interval and ready for use without any calculation.

It must be noted that these tables only permit one repetitive dive. During the trials, Dr. Fructus attempted to use the model to design tables for a second repetitive dive but the project aborted after a series of serious Type II DCS occurrences.

Surface decompression tables were provided for limited exposures. The model ignored the ascent to the surface but introduced a safety margin to compensate for it. These tables remained in use at Comex until 1986. At this time, the concern became the increasing number of Type I DCS associated with deep and/or long exposures. This risk was documented statistically using 60,000 man-exposures stored in the Comex computer data base (Imbert and Bontoux, 1986) and the tables were revised.

#### The 1986 Comex Air Tables.

New tables were calculated using an extremely simple model (unpublished). It consisted of an unlimited series of tissue half-times associated to a single M-value and had only 3 parameters or degrees of freedom. The parameters were determined by fitting the model predictions to the Comex 1974 table exposures using the maximum likelihood method (Homer and Weathersby, 1985).

Because the model was fitted to data which only contained Type I DCS, it is recognized that its predictions remain limited to this type of DCS. However, the new set of decompression tables was successfully validated during two years on Comex work sites, both for in-water and surface decompression, single and repetitive dives (Imbert and Bontoux, 1987) without any Type II DCS recorded. These tables became the 1986 Comex tables and were later included in the new 1990 French regulations.

The 1986 Comex tables introduced a method for determining a decompression after a split-level dive. The principle is based on the equation:

$$P_1 \cdot t_1 + P_2 \cdot t_2 \leq P_e \cdot (t_1 + t_2)$$

Where:

- $P_1$ : pressure at the first work level,
- $t_1$ : time at the first work level,
- $P_2$ : pressure at the second work level,
- $t_2$ : time at the second work level,
- $P_e$ : pressure at the equivalent depth.

Using an exponential tissue model, this holds true when the first level is the deeper one and allows selection of a decompression for a two-level dive using an equivalent depth  $P_e$ , computed from the above equation. The equivalent depth can be derived from a simple table without calculation (figure 1).

**TABLE OF EQUIVALENT DEPTHS FOR SPLIT LEVEL DIVING**

TIME SPENT AT WORK LEVEL	DEPTH OF WORK LEVEL														
	9 m	12 m	15 m	18 m	21 m	24 m	27 m	30 m	33 m	36 m	39 m	42 m	45 m	48 m	51 m
5 min	5	6	8	9	11	12	14	15	17	18	20	21	23	24	26
10 min	9	12	15	18	21	24	27	30	33	36	39	42	45	48	51
15 min	14	18	23	27	31	36	41	45	50	54	59	63	68	72	77
20 min	18	24	30	36	42	48	54	60	66	72	78	84	90	96	102
25 min	23	30	38	45	52	60	68	75	83	90	98	105	113	120	128
30 min	27	36	45	54	63	72	81	90	99	108	117	126	135	144	153
40 min	36	48	60	72	84	96	108	120	132	144	156	168	180	192	204
50 min	45	60	75	90	105	120	135	150	165	180	195	210	225	240	255
60 min	54	72	90	108	126	144	162	180	198	216	234	252	270	288	306
70 min	63	84	105	126	147	168	189	210	231	252	273	294	315	336	357
80 min	72	96	120	144	168	192	216	240	264	288	312	336	360	384	408
90 min	81	108	135	162	189	216	243	270	297	324	351	378	405	432	459
100 min	90	120	150	180	210	240	270	300	330	360	390	420	450	480	
110 min	99	132	165	198	231	264	297	330	363	396	429	462	495		
120 min	100	144	180	216	252	288	324	360	396	432	468	504			
130 min	117	156	195	234	273	312	351	390	429	468	507				
140 min	126	168	210	252	294	336	378	420	462	504					
150 min	135	180	225	270	315	360	405	450	495						
180 min	162	216	270	324	378	432	486	540							
210 min	189	252	315	378	441	504	567								
240 min	216	288	360	432	504	576									
270 min	243	324	405	486	567										
300 min	270	360	450	540											

Always work out the calculation of the equivalent depth before the dive in order to make sure there is an available corresponding decompression table.

**HOW TO USE THE TABLE :**

- Determine the first working depth D1 and the associated bottom time T1.
- Enter the table with D1 and T1 and read the coefficient C1.
- Determine the second working depth D2 and the associated bottom time T2.
- Enter table with T2 and D2 and read coefficient C2.
- Add T1 to T2 to obtain the total bottom time T3.
- Add C1 to C2 to obtain the sum of the coefficient C3.
- Use the table to determine the equivalent depth. Find T3 in the time column. Read across to find the coefficient equal to or greater than C3. Read up from this to get the equivalent depth.
- Select the decompression table using this equivalent depth and T3 as bottom time.

**Figure 1. The Comex method for calculating split-level decompression using an equivalent depth. Two levels are permitted but the first one must be the deepest one.**

**Use of the Comex Air Procedures**

**The divers.**

Each year, between 350 to 600 divers are involved in air diving on Comex work sites. Most of them carry out no more than 10 air dives per year and concentrate on saturation diving. Others specialize in air diving operations and may perform more than 60 air dives per year (figure 2).

**The diving methods.**

Air table possibilities depend on the diving methods used. SCUBA diving is restricted to shallow and short dives. Surface supplied diving constitutes the majority of commercial dives, the divers being

generally deployed using a basket or a wet bell. TUP diving allows a better control of the depth and a higher comfort of the diver but remains marginal because of the cost of mobilization of bell diving gear.

**Table 1: 1990 Comex air diving activity sorted according to the diving methods.**

<u>Diving method</u>	<u>SCUBA diving</u>	<u>Surface supplied diving</u>	<u>TUP diving</u>
Number of dives	1426	10584	61
Percentage	12%	87.5%	0.5%

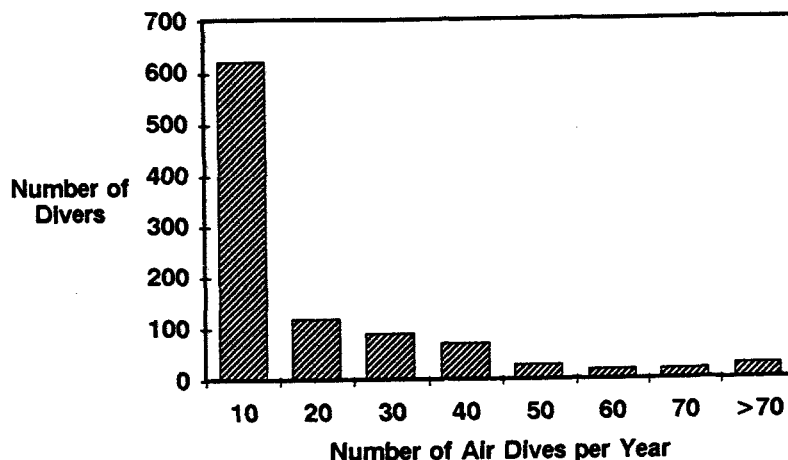

**Figure 2. Chart of the number of air dives carried out each year by the Comex divers.**

#### The decompression procedures.

In France, the risk of Type II DCS following sur-D tables was soon recognized and surface decompression was banned by the 1974 French regulations. Surface decompression has been rehabilitated in the 1990 French regulations but Comex has kept a tradition of in-water decompression while the rest of the diving contractors use mostly sur-D tables. Generally, in-water decompression is used in warm waters such as in West Africa, Middle East and Far East while surface decompression is preferred in the North Sea.

#### The repetitive tables.

Repetitive diving represents only a small fraction of the Comex diving activity. The supervisors prefer to organize the job with one long dive per day rather than two short ones. This allows rotation of the various functions in the team (diver, tender, stand-by diver). It must also be admitted that the repetitive decompression times are longer and difficult to fit within the 12 hour shift.

**Table 2 : 1990 Comex air diving activity sorted according to single and repetitive dives.**

<u>Decompression method</u>	<u>single dives</u>	<u>repetitive dives</u>
Number of dives	11,486	585
Percentage	95%	5%

Repetitive diving is sometimes required for operational reasons, such as tidal diving. This is the case for instance in the southern North Sea or in Argentina where three tides per day and strong currents make diving only possible during the short slack water periods when the tide turns. The problem was

addressed in the Guidance Note No. 048 of the U.K. Association of Diving Contractors with special attention to the personnel level.

### Results and Discussion

#### Yo-yo diving.

Yo-yo diving is unfortunately a common practice, even though it has always been recognized as a dangerous procedure in diving manuals. Although yo-yo diving may be suspected as a contributing factor in any serious DCS, it is interesting to study its influence on DCS occurring in the air no-stop decompression area. This permits elimination of the possible role of the decompression table.

The Comex data base holds records of 4 Type II DCS for such exposures, 3 of them having a recognized history of pressure changes and the last one a too rapid ascent to the surface, as presented in the table below.

Table 3. Case history of 4 Type II DCS occurrences with the air no-stop decompression exposures.

Case	Max. Depth	Bottom Time	Comments
1	12 m	89 min	Inspection work, several ascents to the surface. Paralysis of the face. Symptom reported 40 h after the end of the dive.
2	9 m	212 min	Work on a riser clamp, heavy swell (3m). Vertigo and nausea. Symptoms reported 30 min after the end of dive.
3	33m	15 min	SCUBA diving, too rapid ascent to the surface. Visual problems, pins and needles. Symptoms reported 2 h after the end of the dive.
4	21 m	30 min	Inspection work, several depth changes. Vertigo, pins and needles. Symptoms reported 20 min after the end of dive.

These cases indicate a strong correlation between yo-yo diving and the risk of Type II DCS in the no-stop decompression exposures. Such DCS cannot be accounted by the tissue gas load model - the tissue gas load is minor and does not even require a decompression stop - but are simply explained by the arterial bubbles model.

Similar cases have been compiled by T. Shields in the DOE report. A total of 6 Type II DCS are mentioned for no-stop decompressions recorded between 1982 to 1988. No information is provided on the dive profile of these accidents.

This is the problem of the investigation of Type II DCS because the diving supervisors usually do not report the pressure changes in the dive logs. It is also the limit of computer data bases collecting the information contained in the diving reports. They are unable to consider the eventual pressure changes and thus correlation of Type II DCS and dive profiles. The alternative would be to work on information recorded continuously with electronic dive loggers, but these devices remain expensive and very demanding in computer power for processing records.

#### Surface decompression diving.

There is one case where the pressure variation can be documented without a dive recorder, *i.e.* surface decompression. In surface decompression the ascent to the surface is built into the dive

procedure. The surface interval is of course variable but we know that it is restricted to 5 minutes in the U.S. Navy procedures and to 3 minutes in the Comex tables. Surface decompression is an interesting opportunity to test the predictions of the arterial bubble model by comparing sur-D tables with tables using a continuous ascent to the surface, such as in-water or TUP decompressions.

The comparison is made between the two methods in Table 4. The first source of information is the DOE report and the data are extracted from the 1982 to 1986 operations. The second source is data from the Comex data base on air dives recorded from 1976 to 1983 (Imbert and Bontoux, 1986). Both have been combined for the in-water and TUP decompressions in the last column. The limit of such a comparison is that the safety performances of a table much depend on the exposures selected and it must be verified that the partition of the exposures was the same in sur-D, in-water and TUP dives considered in the test. This appears to be an acceptable assumption considering the various exposure patterns expressed using the "Prt index" (Pressure x square root of time) defined by Dr. T. Shields in the DOE report (Fig.3).

Table 4. Comparison of performances of sur-D and in-water or TUP tables from different sources.

Source	DOE report sur-D 1982-86	DOE report in-water and TUP 1982-86	Comex in-water and TUP 1977-86	Combined DOE + Comex in-water and TUP
Number of dives				
All exposures	49,742	11,867	31,196	43,063
Number of Type I	152	25	118	143
Percentage	0.30%	0.21%	0.38%	0.33%
Number of Type II	89	5	4	9
Percentage	0.18%	0.04%	0.01%	0.02%

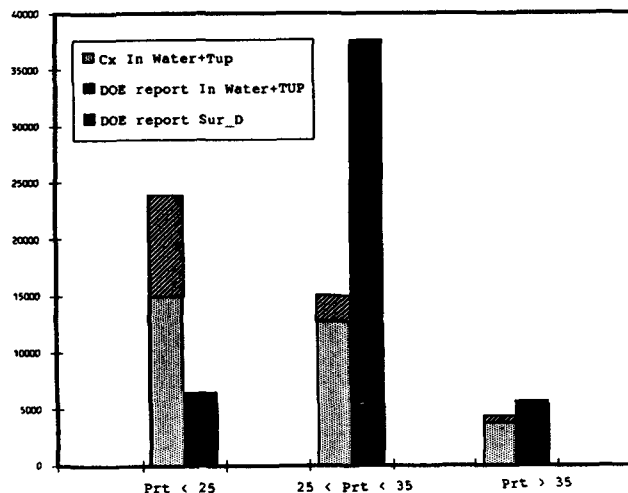

Figure 3: Comparison of exposures patterns of the DOE report surface decompression dives and the combined DOE report/Comex in-water and TUP decompression dives presented in Table 4. The exposures are categorized according to the Prt index (Pressure x square root of time) defined by Dr. T. Shields in the DOE report.

First, it can be noted that the Type I DCS rates appear to be similar for sur-D and in-water or TUP decompressions. Second, it appears that the sur-D have a significantly ( $p < 10^{-6}$ ) higher rate of Type II DCS than in-water or TUP decompressions. This is much in favor of the arterial bubbles model that recommends continuous ascent to the surface. There is also some doubt that the few Type II DCS

recorded with in-water or TUP decompression might be associated with some pressure changes or yo-yo diving but this cannot be demonstrated with present data bases.

These results show the limit of the Dr. T. Shields' approach in the DOE report. The limiting line drawn in the pressure versus time diagrams permits the separation of Type I DCS but certainly not Type II, because of their different mechanism. The exception is surface decompression, where the pressure change is integrated into the procedure and thus, well documented. In this case it is justified to expect to define a frontier between high and low Type II DCS risk exposures and this is effectively observed for sur-D tables in the DOE report. It would be interesting to know how this frontier is defined for diving companies that use 15m recompression for sur-D. However, such a limit does not apply to in-water decompressions, where the pressure variations are random. The results thus support the DSM limiting exposures for surface decompressions, but not for in-water decompressions. In any case, if in-water decompressions were to be restricted, as they have shown to be safer, their limit should be more permissive.

### Repetitive diving.

There is a second case where the pressure variations are defined in the procedures, that is repetitive diving. In repetitive diving a recompression occurs at the beginning of the second dive, after a surface interval that may vary from 0 to 12 hours. The 12-hour surface interval is considered by the U.S. Navy manual sufficient for the divers to clear any effect from the previous dive. The Comex 1974 tables used to consider an 8-hour surface interval for a single dive but this was changed to 12 hours in the last revision to align with the U.S. standards, purely for political considerations. Table 5 below presents data from the Comex data base on repetitive dives performed from 1977 to 1986.

Table 5. Safety of 1974 Comex air repetitive tables sorted according to the surface interval.

<u>Interval</u>	6:00	4:00	3:00	2:00	1:30	1:00	0:30	0:00
Number of dives	2688	1371	321	254	110	287	343	140
Number of Type I	4	5	2	1	1	4	1	0
Percentage	0.15%	0.36%	0.62%	0.39%	0.90%	1.39%	0.29%	0%
Number of Type II	0	0	0	0	0	0	0	0
Percentage	0%	0%	0%	0%	0%	0%	0%	0%

According to the arterial bubble model, the problems in repetitive diving are expected to happen with short surface intervals. However, the data collected in this area are insufficient to draw any conclusions. The longer surface intervals only, and especially the 6-hour surface interval, can support a statistical analysis. These repetitive tables have only produced Type I DCS, and their rate of incidence does not significantly differ from the one for single dives.

This data confirms the importance of the time factor. It seems that the number of available bubbles supposed to be able to pass the lung filter significantly decreases as the time passes. It appears that, after 6 hours, the recompression following the beginning of the second dive no longer produces arterial bubbles.

### Split-level diving.

Split-level diving tables have been regularly used since their introduction and approximately 1,000 man-exposures have been recorded, all with in-water decompression. The way the Comex procedures are conducted, starting with the deeper level first, is unlikely to produce pressure changes with dramatic consequences. Effectively, no problem of decompression of any type has been reported with these tables.

### Conclusion

Two models have been used, the tissue gas load model used by Dr. T. Shields in the DOE report and the arterial bubbles model, to analyze short and/or repetitive recompressions in commercial air diving procedures.

The arterial bubbles model successfully permitted correlation of Type II DCS occurrences with depth changes or recompressions. The contributing effect was found significant in yo-yo diving and surface decompression diving. In repetitive diving, the available data indicate that the risk of Type II decreases as the surface interval increases. No problem of any type was encountered with the Comex split-level tables.

This work shows the limit of Dr. T. Shields' approach in the DOE report. The pressure versus time diagrams can effectively describe the Type II DCS partition when the pressure variations are built into the procedures as for surface decompression, but not when they are random as with the in-water decompression. The arterial bubble model thus supports the limits imposed by the DOE for surface decompressions but not for in-water decompressions. In any case, if in-water decompressions were to be restricted, the data collected show that the limits should be more permissive.

This work permits to recall, after the 1990 EUBS workshop at Amsterdam, that future improvements in decompression safety will have to rely on accurate dive profile recording based on electronic dive recorders and the associated computer treatment capacity.

Finally, the study allows to draw an immediate practical conclusion. The highly random process involved in the generation of the arterial bubbles makes table designers desperate to ever find a model for such events. If no table can be produced to prevent Type II, the divers will have to learn to avoid depth changes and pressure variations. This new philosophy could be summarized as follows:

- use the right table to avoid Type I and,
- use the right procedures to avoid Type II.

### References

- Giles, R. 1989. Decompression sickness from commercial offshore air-diving operations on the UK continental shelf during 1982 to 1988. Report from the UK Department of Energy.
- Hennessy, T.R. 1989. On the site of origin, evolution and effects of decompression microbubbles. Proceedings of the International Symposium on Supersaturation and Bubble Formation in Fluids and Organisms. Trondheim, Norway, June 6-10, 1989.
- Hills, B.A. and P.B. James. 1982. Spinal decompression sickness: Mechanism studies and a model. *Undersea Biomed Res.* 9(3): 185-201.
- Homer, L.D. and P.K. Weathersby. 1985. Statistical aspect of the design and testing of decompression tables. *Undersea Biomed. Res.* 12(3): 239-249.
- Imbert, J.P. and M. Bontoux. 1986. Safety analysis of French 1974 air decompression tables. Proceedings of the Undersea Medical Society Workshop on Decompression in Surface-Based Diving. Tokyo, September 12, 1986.
- Imbert, J.P. and M. Bontoux. 1987. A method for introducing new decompression procedures. Proceedings of the Undersea Medical Society Workshop on Validation of Decompression Schedules. Bethesda, Maryland, February 13-14, 1987.



- Imbert, J.P. and S. Montbarbon. 1990. The Comex Diving Data Base. Proceedings of the EUBS Workshop on Operational Dives and Decompression Data: Collection and Analysis. Amsterdam, August 17, 1990.
- James, P.B. 1982. The size distribution of gas emboli arising during decompression. A review of the concept of critical diameter of gas emboli. Proceedings of the XIIIth Annual Congress of the EUBS, Lubeck, Germany, October 5-8, 1982.
- U.K. Department of Energy Diving Safety Memorandum No. 4/1988 - Exposure limits for air diving.
- U.K. Department of Energy Diving Safety Memorandum No. 7/1986 - Exposure limit for offshore air diving.
- Workman, R.D. 1965. Calculation of decompression schedules for nitrogen-oxygen and helium-oxygen dives. U.S. Navy Experimental Diving Unit, Research report 6-65, Washington D.C.

**CAL DIVE INTERNATIONAL**

*Jack Reedy*  
CalDive International  
PO Box 1016  
Morgan City, LOUISIANA 70381 U.S.A.

I will give you an introduction to the type of commercial diving done in the Gulf of Mexico by the number of dives by type, the types of decompression and the number of decompression incidents.

Surface supply diving on air in the Gulf of Mexico may be conducted to a maximum depth of 220 feet. Air diving is limited to 190 feet by Coast Guard regulations, with the exception of bottom times of 30 minutes or less. Surface supply diving on mixed gas may be conducted down to depths of 300 feet. We normally start thinking about mixed gas somewhere around 170 feet. Closed bell or saturation diving, or bounce diving, may be conducted in excess of 300 feet. Scuba diving is rarely used. When it is, it has a limit of 130 feet and in no-decompression mode only. Other surface supply dives, approximately 35 to 40 percent, are mixed gas dives, the balance being air dives. At present, I do not know of any commercial company that is using mixed gas, other than heliox. No-decompression scuba diving accounts for less than one percent.

For the various types of decompression, I know of no commercial company that uses the U.S. Navy Tables exactly as they are written. Most of us use almost identical tables in some cases. Surface decompression comprises about 95 percent of all the decompression done in the Gulf of Mexico. One contractor relates that he had over 10,000 dives on the same table. Of those 10,000 dives, over a five year period, he had five incidences of decompression sickness, involving three employees. Two employees had a repeat saturation, two each. They were on the same table, with surface decompression. All presented as Type I and were successfully treated.

In commercial diving, in-water decompression is often not feasible because of the sea state, the water temperature, the depth control and the inability to use oxygen. Several of our tables do not permit in-water oxygen breathing. Additionally, with ongoing operations, you may need to move the vessel. The number of decompression incidences includes three types of bends.

- 1) Possible bends. Possible bends are treated and counted as bends and are a group in our statistics. An example would be of a tender who worked on deck all day moving sandbags around and then gets an opportunity to dive and may very well have some sore muscles during his decompression.
- 2) Deserved bends. Deserved bends occur when an incident can be attributed to an identifiable cause, such as an incorrectly administered table, failure to take environmental considerations into account, or inappropriate diver-worn gear.
- 3) Undeserved bends, for which no identifiable cause can be found.

Grouping these three categories together, the bends rate for the Gulf of Mexico commercial diving companies ranges from about 0.10% to zero. In summary, there are many thousands of surface supply dives made in the Gulf of Mexico each year. 95% of those dives are decompressed using surface decompression and the bends rate, is about 0.10%. The consensus of the Gulf of Mexico contractors is, "If it ain't broke, don't fix it!"

## **SUBSEA INTERNATIONAL**

**Gary L. Beyerstein**  
SubSea International, Inc.  
1600 Canal Street  
PO Box 61780  
New Orleans, LOUISIANA 70161 U.S.A.

### **Introduction**

I will be speaking specifically about SubSea International, but most of the things I will talk about are germane and relate to the entire commercial diving industry domestic experience in the Gulf of Mexico. We perform a lot of dives in all the diving modes, except we do not use scuba. We almost never use in-water decompression. We do have proprietary tables as well as modified U.S. Navy Tables. I want to stress strongly that, even though attitudes have changed and we have continuous litigation in our industry, a bends hit used to be considered part of the job but is now a red letter event to us. However, even more important than preventing DCS, is curing it.

### **Sur-D-O2**

Commercial diving is by its very nature multi-day diving, so we do not even track that. It is assumed that when we go on a job with a diving crew, we dive through the day, through the week, until the job is over. A vast number of our dives are no-decompression. When I mention standard air, that includes repets and miniscule amounts of in-water decompression. The vast majority of all decompression diving is done Sur-D-O2. We routinely repet-up and our Sur-D-O2 is breathing air and mixed gas. We also perform bell bounce and saturation excursions. A distribution of the last two years of SubSea's dives up to 70 feet represents about 7,000 dives and the rest totals about 8,000 dives. Now, all of these 7,000 dives would be no-D's and most of them would be repets. Most repets would be repet-ups. In fact, the only decompression dives that I know of were due to an unusual circumstance on a particular job where a customer threw something unexpected at us. It was not planned and we ended up doing 8 in-water decompression dives where the chamber was not accessible in the time permitted. We ended up getting one bend there. Every dive was going to be their last and then they were ordered 50/50, so we expected that to happen. I have taken steps so that it will never happen again.

If you compare our Sur-D-O2 dives, you will find a ratio of about 2:1. In other words, we do twice as many dives I am calling standard air but are really no-D and repet-up or repetitive dives. A substantial number of these would be repetitive dives. 50 dives probably represent repet-ups that repeted-up on a Sur-D-O2 schedule at 40 feet.

### **Table Development**

SubSea has had a long history of proprietary table development. We have gone through the days of Alan Krasburg and the founder of our company, Dan Wilson, and have been exclusively for the last decade or more with Dr. Lambertsen and EcoSystems. We have some successful special tables that we use for extended duration Sur-D-O2, breathing 50/50 N<sub>2</sub>O<sub>2</sub> and other mixtures in the water for hyperbaric welding. This is all under 100 feet, bounce bell diving.

Our saturation decompression is faster than the U.S. Navy and better. We have a better record and we are very satisfied with that. We do custom tables as needed. Unfortunately, there are two particular tables we should be using, but we got those in the early 1980's right about the time of the downturn of the industry. They were not exactly what we wanted. We got what we asked for, but we did not ask for the right thing because of the problem of lack of participation of operations and, of course, in our industry the safety conscientiousness has been increasing. At that particular time, economic considerations would not allow us to compete with the reduced bottom times and extended decompression that those tables involve. So, we continued to use the U.S. Navy tables and began a program of modifying them. It is an ongoing process and is temporary.

Table 1. SSI Standard Air

Depth Range in Feet	1989	1990	Total Dives
0 to 40	2043	1891	3934
41 to 50	1195	787	1982
51 to 60	479	594	1073
61 to 70	266	244	510
71 to 80	65	131	196
81 to 90	40	40	80
91 to 100	30	40	70
101 to 110	21	30	51
111 to 120	9	21	30
121 to 130	15	20	35
131 to 140	14	5	19
141 to 150	7	4	11
151 to 160	3	5	8
161 to 170	2	0	2
171 to 180	8	0	8
181 to 190	0	0	0
191 to 200	0	0	0
201 to 210	0	0	0
211 to 220	0	0	0
221 to 230	0	0	0
<b>Total Dives</b>	<b>4197</b>	<b>3812</b>	<b>8009</b>

Table 2. SSI Sur D O2

Depth Range in Feet	1989	1990	Total Dives
0 to 40	35	15	50
41 to 50	259	305	564
51 to 60	356	205	561
61 to 70	111	281	392
71 to 80	182	278	460
81 to 90	88	88	176
91 to 100	174	91	265
101 to 110	51	107	158
111 to 120	20	164	184
121 to 130	153	121	274
131 to 140	334	114	448
141 to 150	50	62	112
151 to 160	33	53	86
161 to 170	30	47	77
171 to 180	44	39	83
181 to 190	24	10	34
191 to 200	3	14	17
201 to 210	0	5	5
211 to 220	5	1	6
221 to 230	0	2	2
<b>Total Dives</b>	<b>1952</b>	<b>2002</b>	<b>3954</b>

We are expecting new generation tables to come out of Michael Gernhardt and Dr. Lambertsen's work from the North Sea initiative. They are field validated and it was fun to listen to Dr. Hamilton tell me that I was doing exactly what they rubber stamped for me. I did not realize I was a one-man decompression decision board. The tables are successful, but not optimum.

### Decompression

I take great exception to my colleague from the North Sea. I think that the fundamental difference in whatever the causes of bends or whatever model you take, is the quality of the decompression and not the inherent exposure. We routinely decompress safely from saturation exposures - that is your maximum exposure - so the tables are what we have to look at. Simply drawing a PrT index at 25 and saying that is okay, is a reflection of the table and not what is going on physiologically in the body. These tables are eclectic. They are in-house and they have been copied and are in use around the industry in various places. I have no control over that.

U.S. Navy Tables Modifications:

- Shortened no-D, bottom time limits
- 50/50 N<sub>2</sub>O<sub>2</sub>
- Deeper/longer water stops resulting in a reduced surface interval
- 50 fsw initial chamber stop followed by an extended slide to the surface from 40 feet depending upon the time, either in 10 minutes or 20 minutes
- Universal commercial practice to provide air breaks, usually at the 20 and 5 schedule.
- We provide more schedules for a given depth and have our tables extended up to 40 feet for Sur-D-O<sub>2</sub> and down to 230 feet (10 feet deeper than the maximum permitted in case somebody finds a hole and needs a table).
- We all repet-up and repet on Sur-D-O<sub>2</sub>, usually after six hours, if not over an O-group and if not below 170 foot.
- SubSea mandates a 12-hour interval between going from an air dive to a mixed gas dive.

Comparing no-D limits from eight major tables around the world, the U.S. Navy is the maximum and then there are subsequent reductions. The Norwegians have the lowest at 40 and the Canadian DCIEM standard table holds the line down to 120 and COMEX is the lowest at the 130. Those percentage reductions from the U.S. Navy tables range from a low of 32% to a high of about 53%. SubSea's reductions range from a low of 8% to a high of 50% (Table 3 ).

Table 3. No-Decompression Limits. Percentage reductions from U.S. Navy

Depth (Ft.)	U.S. Navy	R.N.	Can. Sht.	Can. Std.	Cx.	Nor.	Ro-gers	Sub Sea	Max. Red.	SSI Red.
30	—	232	400	380	—	—	—	—		
40	200	137	170	160	180	135	140	180	32%	10%
50	100	72	75	60	80	85	80	85	40%	15%
60	60	46	50	35	50	60	55	55	42%	8%
70	50	38	35	24	30	40	40	40	52%	20%
80	40	27	25	19	25	30	30	30	53%	25%
90	30	23	20	15	20	25	25	25	50%	17%
100	25	18	15	12	15	20	20	20	52%	20%
110	20	16	12	11	10	15	17	15	45%	25%
120	15	12	10	9	10	10	14	10	40%	33%
130	10	11	8	8	5	10	12	5	50%	50%

Time in Minutes

We find that going back to that terrific number of no-D dives, the repets and repet-ups in the shallow ranges, we do not have a problem. In fact, on that first table of 8,000 dives, we had only one bend and we expected it. It should not have happened. We had one totally unexplained bend in the very shallow, less than 60 foot range and he was at less than 50 percent of the no-D limits of our reduced no-D table, with no other table compromise identifiable, so it was just one of those things that happen.

We think all of our tables in the industry are superior to the U.S. Navy, which is why we use them. We still have bends when doubt exists if they are in fact bends, even after a test of pressure. Some bends are deserved and they are deserved either through table compromise or through operational and environmental or physiological factors.

I report SubSea bends as follows: All treatments are counted as DCS and reported as such to our customers and through the ADC Incident Data Reporting Sheet; Negative tests of pressure are not counted if the neurological is negative and if no modification or subsequent deterioration of symptoms occurs. We further identify our DCS cases and evaluate them to help us check our table performance, both for the non-deserved and then the deserved bends. Furthermore, we break down our deserved bends into two categories:

- **Category A:** Occurrences where there was identifiable table compromise due to error or operational circumstances. The judgement is that the compromise caused the bend (e.g. missed or shortened water stop, exceeded surface interval, gas compromise such as improper bottom mix or use of 50/50 N<sub>2</sub>O<sub>2</sub> or oxygen in the chamber.
- **Category B:** Occurrences without identifiable table compromise, but three or more operational/environmental/physiological factors were simultaneously present without any table padding (e.g. lack of fitness/obesity, excess fatigue before or during dive, temperature factors, suspected pneumo error, sea state, age, previous bends history, recent soft tissue injury, excess CO<sub>2</sub>, cramped position or exercise during deco, etc.)

In almost 22,000 air dives, SubSea shows 20 cases of DCS, 14 Type I and 6 Type II. However, Type II cases are about 43% of all DCS in our experience. Not all cases were reported initially as Type II's, but after subsequent evaluation, it became apparent that this was a Type II maybe masked by a Type I or incorrectly diagnosed, so we re-categorized it. Of those 20, we had 6 Category A deserved bends. Those were the table compromises and, 4 Category B, which gives a roughly 50/50 ratio of deserved to non-deserved bends. That is a total incident rate of < 1 bend/1000 dives for everything. If we include our deserved bends, about 1/2000 dives. My goal would be to have our total bends at 1/2000 and our deserved bends around 1/4000. I think that is achievable, but certainly not with the tables we have now. This is the factor that drives our industry and what I was alluding to before. In the last ten years, we have had three occasions of Type II symptoms with permanent sequelae remaining. Two cases were genuine gas problems and one was a malingerer, who got a settlement anyway even though we wrote the Jones Act on it.

The recent Supreme Court almost guarantees that any diver is going to be considered a Jones Act Seaman which gives his employer unlimited liability, even for non-occupational diseases. Bends are like backs in the industry. They are genuinely crippling when they occur and they are very easy to fake if they are not there, so this is something we live with. At any rate, two genuine gas bends and two genuine lawsuits with major settlements. The first one happened five years ago, and I was not there to take the call. I was on vacation and I believe that if the present procedures that we have instituted in our company were in place, or indeed if I had been there to take the call, it would not have happened. The last one happened last year and again prompted another change in our treatment procedures charts. There was a total failure of the cellular phone offshore, so they could not get in touch with us, along with some other factors.

### **Treatment**

We do treat the bends aggressively with training, tests of pressure and neurological examinations. All the divers are examined neurologically by each other as a baseline at the beginning of the job and then we do an initial rapid exam after every dive and every chamber run. And, of course, before any treatment commences, if it is an obvious pain-only Type I with no obvious overt Type II symptoms, we have Dr. Lambertsen available at any time of the day.

We use a blend of some U.S. Navy and other treatment tables. We use part of COMEX CX-30 and CX-30A and our secret weapon is Table 7A which allows you to treat to a maximum treatment depth. For the Gulf of Mexico, the maximum surface dive would be 300 feet on gas. We can go to 366 feet and surface the diver up without having a saturation treatment schedule in the chamber in 13 hours and we can do that with flushing and letting the  $ppO_2$  climb. We can run this chamber treatment up to 165 ft on air in 13 hours and give him good treatment at depth.

Our TPCs (Treatment Procedures Charts) are done on three charts. TPC-I is for symptoms manifesting at one atmosphere and the recent change I have alluded to is that we are now treating all Type II symptoms, no matter how minor, and multiple pain-only occurrences at depth, especially with gas diving or deeper air diving like Dr. Fife observed. We have found that a major Type II does not respond at 60 feet. It needs more aggressive therapy, especially use of 50/50  $N_2O_2$  at 165 feet. We have incorporated this into our schedule with treatment depths at 100 feet, at 200 feet on air, heliox is available, 165 on 50/50  $N_2O_2$  and the ability to go into circular loops if it fails. Chart II is for saturation. Chart III is for bends that occur under pressure, either in the water, during the surface interval or during routine chamber decompression.

### **Conclusion**

The problems we face and the impediments to near zero bends stem from intense competition, aging divers, flood of new hires missing middle level, unlimited liability/litigation, old attitudes about bends and new legislation ("Employee with disabilities" Act).

Some potential solutions would be unity and mutual cooperation between diving contractors and scientific community, more training, a unified data bank, cost effective dive monitoring for table validation, increased support from our customers (some still try to evaluate diving companies by their table efficiency, bottom time versus decompression time), industry standards for tables and therapy and continued support of the Association of Diving Contractors.

**AMERICAN OILFIELD DIVERS, INC.**

**H.G. (Bud) Mills**  
 American Oilfield Divers, Inc.  
 PO Box 507  
 6219 Highway 90 East  
 Broussard, LOUISIANA 70518 U.S.A.

**Introduction**

Prior to 1987, American Oilfield Divers (AOD) had a bends ratio between 2-3% using U.S. Navy air tables and gas partial pressure tables. Early in 1987, AOD modified the air procedures and changed to a modified SEACON gas table, using 50/50 N<sub>2</sub>O<sub>2</sub> during in-water decompression.

**Table 1. Summary of AOD dives**

Year	Bends	Dive totals	Bends rate
1985	n/a	5,400	2-3%
1986	n/a	6,000	2-3%
1987	I: 8	6,500	0.13%
	II: 9		
1988	I: 4	7,531	0.08%
	II: 6		
1989	I: 7	7,759	0.1%
	II: 8		
1990	I: 12	11,118	0.12%
	II: 14		

Note: during the past three years AOD logged 26,408 dives with 28 bends (1 bend per 943 dives).

**Table 2. 1988 Bends Statistics**

■ TYPE 1 } INDICATES ONE CASE OF BENDS  
 ■ TYPE 2 }  
 7,531 TOTAL DIVES  
 6,885 SURFACE DECOMPRESSION DIVES  
 6,714 AIR DIVES      171 GAS DIVES

DEPTH	JAN	FEB	MAR	APR	MAY	JUN	JUL	AUG	SEP	OCT	NOV	DEC
<u>AIR DIVES</u>												
50' TO 100'		■					■					
100' TO 150'	■											
150' TO 200'	■											
200' TO 220'												
<u>GAS DIVES</u>												
150' TO 200'							■					
200' TO 250'												
250' TO 300'												
300' TO DEEPER												



**Table 3. 1989 Bends Statistics**

7,759 TOTAL DIVES

■ TYPE 1 } INDICATES ONE CASE OF BENDS  
 ■ TYPE 2 }

7,126 SURFACE DECOMPRESSION DIVES

6,697 AIR DIVES 429 GAS DIVES

DEPTH	JAN	FEB	MAR	APR	MAY	JUN	JUL	AUG	SEP	OCT	NOV	DEC
<u>AIR DIVES</u>												
50' TO 100'		■					■		■			
100' TO 150'		■										
150' TO 200'		■										
200' TO 220'												
<u>GAS DIVES</u>												
150' TO 200'												
200' TO 250'												
250' TO 300'							■					
300' TO DEEPER									■			

**Table 4. 1990 Bends Statistics**

11,118 TOTAL DIVES

■ TYPE 1 } INDICATES ONE CASE OF BENDS  
 ■ TYPE 2 }

7,578 SURFACE DECOMPRESSION DIVES

7,324 AIR DIVES 254 GAS DIVES

DEPTH	JAN	FEB	MAR	APR	MAY	JUN	JUL	AUG	SEP	OCT	NOV	DEC
<u>AIR DIVES</u>												
50' TO 100'		■										
100' TO 150'		■	■	■							■	■
150' TO 200'		■									■	
200' TO 220'								■				
<u>GAS DIVES</u>												
150' TO 200'												
200' TO 250'								■				
250' TO 300'		■									■	
300' TO DEEPER												

**Modifications to the AOD Tables**

**A. Air Tables**

1. All dives made on the 100' sur-D-O<sub>2</sub> decompression table (or deeper) followed by chamber decompression required the following:

Time	Depth	Medium
10 min.	50'	O <sub>2</sub>
5 min.	50'-40'	O <sub>2</sub>

Then commence normal decompression time, according to surface air decompression tables.

2. 8 minute ascent time from 40' to the chamber on the surface.
3. Repetitive diving is not allowed on dives deeper than 170'.

4. When using U.S. Navy Air Tables for 130', 140', 150' or 160', decompress diver on the next greater decompression schedule. For calculation of repetitive diving, use actual repetitive group designation letter.
5. There is a minimum 4 hour surface interval requirement between "O" dives.
6. Established the use of decompression mix, 50% O<sub>2</sub> and 50% N<sub>2</sub> for water decompression stops when diving the sur-D-O<sub>2</sub> air tables.
7. If a diver makes 2 "O" dives in a 12-hour period, he must then have a 12-hour surface interval.
8. A diver cannot repet-up once he has reached the repetitive group "O" designation.
9. When repetting up, the diver must ascend at least 33' before obtaining a new repetitive group designation.
10. When taking decompression in the water, the diver should make every effort to change his position frequently so as not to impede the blood flow to a certain area of the body.
11. The diving crew shall work as a team in order to successfully complete the 5 minute surface interval. This 5-minute surface interval shall be from the time the diver leaves his last water stop, surfaces, enters the chamber and immediately starts breathing O<sub>2</sub>, until he reaches 50' in the chamber on O<sub>2</sub>. If this interval is exceeded, additional decompression is given and the crew is written a safety violation ticket, reflected on their quarterly safety bonus.
12. When decompressing in the chamber, the following suggestions will reduce the possibility of DCS:
  - a. Gently move arms and legs every few minutes to allow proper blood flow;
  - b. Use the elastic band to hold the O<sub>2</sub> mask; this eliminates bending the elbow by holding the mask with the hand;
  - c. Take deep breaths every 2-3 minutes to expand the rib cage, and;
  - d. Relax, stay awake and breathe normally.
13. Divers should not extend beyond group "O" except for emergency situations.
14. No-decompression limits for air dives shall be 80% of the U.S. Navy limits when a decompression chamber is unavailable. No repetitive diving shall be allowed.

**B. Gas Tables**

1. These tables are known as the 50/50 tables. They are calculated for use with 86/14 helium-oxygen bottom mixes. The depth is at the top of each page. This is the actual depth of the dive and not the partial pressures of the gases. Optimum bottom times are reduced and are not to be exceeded without permission.
2. Water decompression mix is 50% N<sub>2</sub> and 50% O<sub>2</sub>.
3. Chamber breathing gas is 100% oxygen.
4. Rate of ascent to the first stop is 25 feet per minute.
5. Rate of ascent during decompression is 10 feet per minute.
6. Travel time between decompression stops is not part of decompression stop time.
7. The 5 minute surface interval includes:
  - a. 1 minute from 40' to the surface;
  - b. 3 minutes on the surface, and;
  - c. 1 minute to 50' in the chamber breathing O<sub>2</sub>.
 (The same procedure applies for staying within the 5 minute surface interval as in the air tables).
8. Chamber decompression

<u>Time</u>	<u>Depth</u>	<u>Medium</u>
15 min.	50'	O <sub>2</sub>
10 min.	50'-40'	O <sub>2</sub>
5 min.	40'	air

Alternate 25 minutes O<sub>2</sub>, then 5 minutes air for the remainder of the chamber time.

9. Ascent rate from 40' after completing chamber time is 10 minutes with the diver breathing O<sub>2</sub>.

## GLOBAL DIVERS AND CONTRACTORS

*Robert K. (Bob) Merriman*  
Global Divers & Contractors, Inc.  
PO Box 10840  
New Iberia, LOUISIANA 70562 U.S.A.

### Problems

Most of the problems associated with multi-level diving procedures can be traced to three areas:

1. Improper supervision;
2. Trying to work the diver all the way to the surface, and;
3. Extending the diver's work time beyond reasonable limits.

#### 1. Improper supervision

Computing decompression or maximum bottom time for multi-level diving requires some math skills and can be confusing unless the supervisor thoroughly understands the correct procedures for computing correct exposure times. Proper training and the use of pre-printed forms to lead the supervisor or lead diver through the computations solves most of the problems incurred with this type of diving.

#### 2. Working the diver all the way to the surface

These procedures appear to offer a way to have the diver work his way all the way to the surface, using his decompression stops to continue work. In the early days of Gulf diving where the water was usually shallow this was successful, but as dives became progressively deeper, problems were incurred. When using these procedures it is important to insure that the diver is never moved to level higher than an already required decompression stop. The dive must also be clearly defined as to work levels and decompression levels. Once the diver has been put on a decompression schedule, the work stops and the diver is decompressed as required with proper attention to his stop depths and stop times.

#### 3. Extending the diver's work beyond reasonable limits

This is essentially an extension of the second problem. When using these procedures, they can, if not properly managed, work a diver beyond his physical limits. The supervisor must be aware of divers' exposure to hard work at a deeper level and use reasonable time limitations at the shallower depths. Keeping the diver to an "O" group or less will usually solve this problem.

### Procedures for Multi-level Diving

1. Maximum depth for use is 190 fsw.
2. Ascent rate of 25 fpm.
3. Dives should not be extended past an "O" repetitive group.
4. Use exact or next greater depth and next greater time for all calculations.
5. When possible, use surface decompression oxygen procedures for decompression.
6. Dives will be planned not to exceed Global Diving & Contractors' standard depth/time limitations.
7. Computed time at each level consists of:
  - residual nitrogen time (if any);
  - actual time at level, and;
  - travel time to next level.
8. Do not allow diver to work during decompression stops.

### Multi-level Dive Computations

CT = Computed Time at Depth  
 RNT = Residual Nitrogen Time  
 AT = Actual Time at Depth  
 TT = Travel Time to Next Depth.

Formula:  $CT = RNT + AT + TT$

#### Worksheet

CT at _____	RNT		+	AT		+	TT		=	_____	Total
_____	_____			_____			_____			_____	Total
CT at _____	RNT		+	AT		+	TT		=	_____	Total
_____	_____			_____			_____			_____	Total
CT at _____	RNT		+	AT		+	TT		=	_____	Total
_____	_____			_____			_____			_____	Total
CT at _____	RNT		+	AT		+	TT		=	_____	Total
_____	_____			_____			_____			_____	Total

Final Decompression Schedule \_\_\_\_\_

#### Sample Computation for Multi-level Dive

Level 1	135 ft.	16 min.
Level 2	122 ft.	10 min.
Level 3	65 ft.	30 min.

##### Step one:

Compute CT at first level:

RNT = 0                      Actual Time = 16 min.

Travel to next level at 25 fpm = 1 min.

##### Step two:

Next greater time on 140' line is 18 min.

##### Step three:

Follow this line across to next dive level 122 ft. (130 ft.).

Line is 19 min. Next greater is 22 min. This is RNT for next level.

##### Step four:

Compute CT for second level:

RNT = 22 min.              Actual Time = 10 min.

Travel to next level = 3 min.

Total = 35 min.

##### Step five:

Next greater time on 130' line is 38 min.

**Step six:**

Follow this line across to next dive level 65 ft. (70 ft.).

Line is 80 min. Next greater is 87 min. This is RNT for third level.

**Step seven:**

Compute for final decompression at level three:

RNT = 87 min.

Actual Time = 30 min.

Travel time is n/a since diver is going into decompression phase and travel will be controlled by decompression schedule.

**Step eight:**

Final decompression will be on a 70 ft. for 120 min. schedule using surface decompression oxygen procedures.

REPET. GROUPS	REPETITIVE DIVE DEPTH (FT.)																
	40	50	60	70	80	90	100	110	120	130	140	150	160	170	180	190	
A	7	6	5	4	4	3	3	3	3	3	2	2	2	2	2	2	
B	17	13	11	9	8	7	7	6	6	6	5	5	4	4	4	4	
C	25	21	17	15	13	11	10	10	9	8	7	7	6	6	6	6	
D	37	29	24	20	18	16	14	13	12	11	10	9	9	8	8	8	
E	49	38	30	26	23	20	18	16	15	13	12	12	11	10	10	10	
F	61	47	36	31	28	24	22	20	18	16	15	14	13	13	12	11	
G	73	56	44	37	32	29	26	24	21	19	18	17	16	15	14	13	
H	87	66	52	43	38	33	30	27	25	22	20	19	18	17	16	15	
I	101	76	61	50	43	38	34	31	28	25	23	22	20	19	18	17	
J	116	87	70	57	48	43	38	34	32	28	26	24	23	22	20	19	
K	138	99	79	64	54	47	43	38	35	31	29	27	26	24	22	21	
L	161	111	88	72	61	53	48	42	39	35	32	30	28	26	25	24	
M	187	124	97	80	68	58	52	47	43	38	35	32	31	29	27	26	
N	213	142	107	87	73	64	57	51	46	40	38	35	33	31	29	28	
O	241	160	117	96	80	70	62	55	50	44	40	38	36	34	31	30	
Z	257	169	122	100	84	73	64	57	52	46	42	40	37	35	32	31	

Figure 1. Repetitive Dive Table

**Summary**

This procedure has been used in commercial diving for many years with much success. With proper supervision and a reasonable time/depth/ work profile, this procedure offers no unusual decompression problems or any increased risk of bends.

### Appendix. Multi-level Diving Computations

CT = COMPUTED TIME AT DEPTH  
 RNT = RESIDUAL NITROGEN TIME  
 AT = ACTUAL TIME AT DEPTH  
 TT = TRAVEL TIME TO NEXT DEPTH

FORMULA: CT = RNT + AT + TT

#### WORKSHEET

CT at 135'/140 RNT AT TT  
0 + 16 + 1 = 17 TOTAL

CT at 122/130 RNT AT TT  
22 + 10 + 3 = 35 TOTAL

CT at 65 RNT AT TT  
87 + 30 + 0 = 90 TOTAL

CT at \_\_\_\_\_ RNT AT TT  
 \_\_\_\_\_ + \_\_\_\_\_ + \_\_\_\_\_ = \_\_\_\_\_ TOTAL

FINAL DECOMPRESSION SCHEDULE

70/120

SURFACE DECOMPRESSION O<sub>2</sub>

REPET. GROUPS	REPETITIVE DIVE DEPTH (FT.)															
	40	50	60	70	80	90	100	110	120	130	140	150	160	170	180	190
A	7	6	5	4	4	3	3	3	3	3	2	2	2	2	2	2
B	17	13	11	9	8	7	7	6	6	6	5	5	4	4	4	4
C	25	21	17	15	13	11	10	10	9	8	7	7	6	6	6	6
D	37	29	24	20	18	16	14	13	12	11	10	9	9	8	8	8
E	49	38	30	26	23	20	18	16	15	13	12	12	11	10	10	10
F	61	47	36	31	28	24	22	20	18	16	15	14	13	13	12	11
G	73	56	44	37	32	29	26	24	21	19	18	17	16	15	14	13
H	87	66	52	43	38	33	30	27	25	22	20	19	18	17	16	15
I	101	76	61	50	43	38	34	31	28	25	23	22	20	19	18	17
J	116	87	70	57	48	43	38	34	32	28	26	24	23	22	20	19
K	130	99	79	64	54	47	43	38	35	31	29	27	26	24	22	21
L	161	111	88	72	61	53	40	42	39	35	32	30	28	26	25	24
M	187	124	97	80	68	58	52	47	43	38	35	32	31	29	27	26
N	213	142	107	87	73	64	57	51	46	40	38	35	33	31	29	28
O	241	160	117	96	80	70	62	55	50	44	40	38	36	34	31	30
Z	257	169	122	100	84	73	64	57	52	46	42	40	37	35	32	31

OCEANEERING INTERNATIONAL

Terry Overland  
Oceaneering International, Inc.  
P.O. Drawer H  
Morgan City, LOUISIANA 70381 U.S.A.

Introduction

"Decompression Procedures Imperil Commercial Divers" and "North Sea Divers in Brain Damage Risk". Newspaper headlines such as these dramatize the hazards of divers using surface decompression techniques and diving below 100 feet.

Can decompression sickness be eliminated?

It is imperative that the diving industry try to eliminate DCS or at least minimize the risk of DCS to the diver. Key factors affecting DCS have been enumerated by previous speakers at this workshop. Reducing the risk of DCS is a complex undertaking wherein the dive tables only constitute one factor in the process. To date, there are only a few independent investigations into the frequency of DCS in commercial divers (e.g. "Decompression Sickness from Commercial Offshore Air Diving Operations on the U.K. Continental Shelf during 1982-1988" by Dr. Tom Shields, *et al.*, 1990) with contributions from the Environmental Medicine Unit of the Robert Gordon Institute of Technology. This report was prepared for the U.K. Department of Energy.

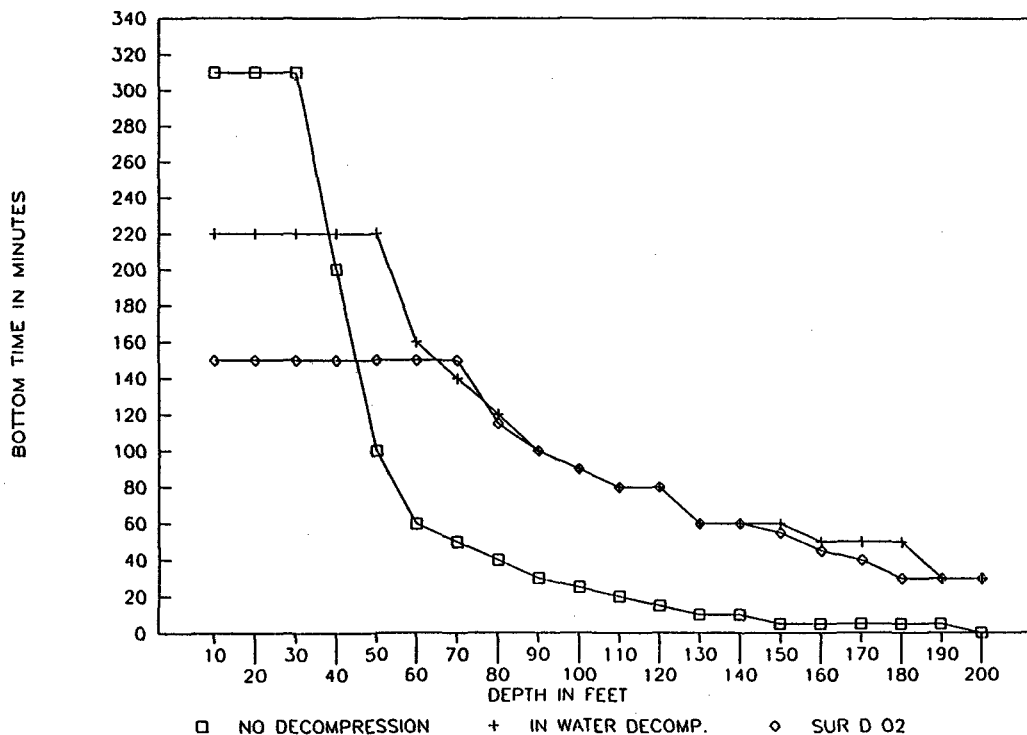
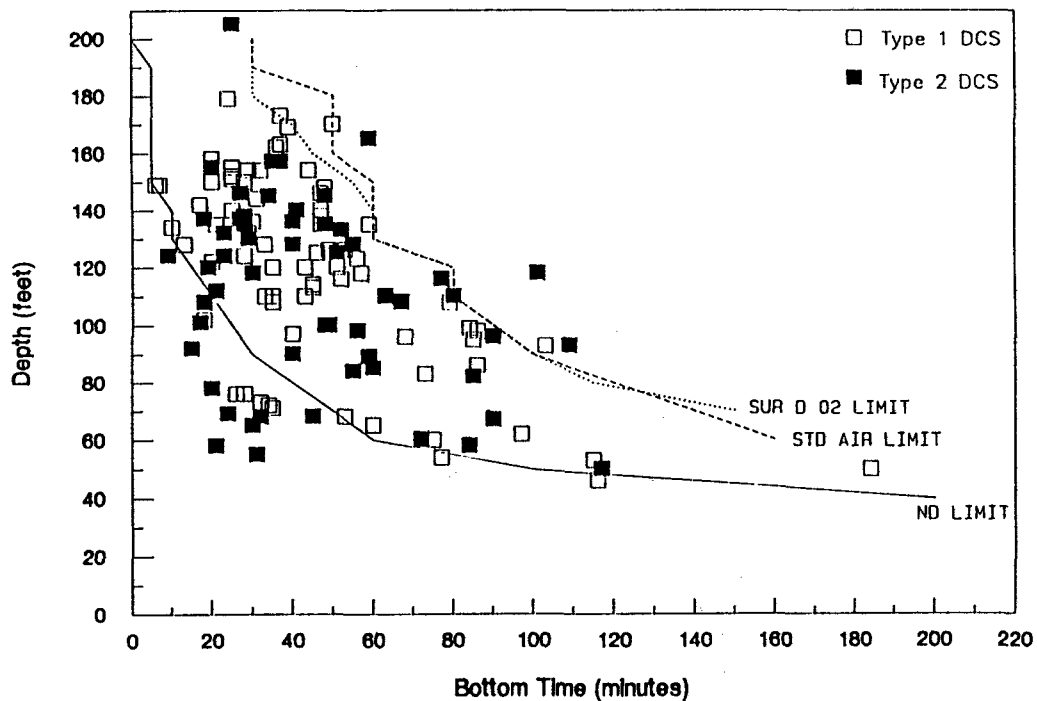

Figure 1. Oceaneering Depth/Time limits.

**Table 1. 1984 - 1990 U.K. vs. Oceaneering air dive statistics comparison**

YEAR	U.K. NORTH SEA				OCEANEERING				AMERICAS			
	TOTAL AIR DIVES	TOTAL D.C.S.	% INCIDENCE	DIVES PER DCS	TOTAL AIR DIVES	TOTAL D.C.S.	% INCIDENCE	DIVES PER DCS	TOTAL AIR DIVES	TOTAL D.C.S.	% INCIDENCE	DIVES PER D.C.S.
1984	23,033	70	0.3%	329	20,633	79	0.383%	261	4,242	10	0.236%	424
1985	22,346	62	0.28%	360	23,784	42	0.177%	566	4,410	16	0.363%	275
1986	20,262	60	0.3%	337	29,915	32	0.110%	934	5,019	5	0.100%	1,004
<b>D.S.M.7/86 AIR DIVE BOTTOM TIME LIMITATIONS</b>												
1987	18,444	36	0.2%	512	27,561	36	0.132%	765	5,060	15	0.296%	337
<b>D.S.M.5/88 AIR DIVE BOTTOM TIME LIMITATIONS</b>												
1988	17,045	17	0.1%	1,002	31,201	33	0.110%	945	5,559	6	0.108%	926
1989					28,385	25	0.088%	1,135	5,507	4	0.073%	1,377
1990					25,555	10	0.039%	2,555	5,151	1	0.019%	5,151



**Figure 2. 1986-1990 Distribution of total DCS.**  
Note the depth/bottom time location of the Type I and II hits.



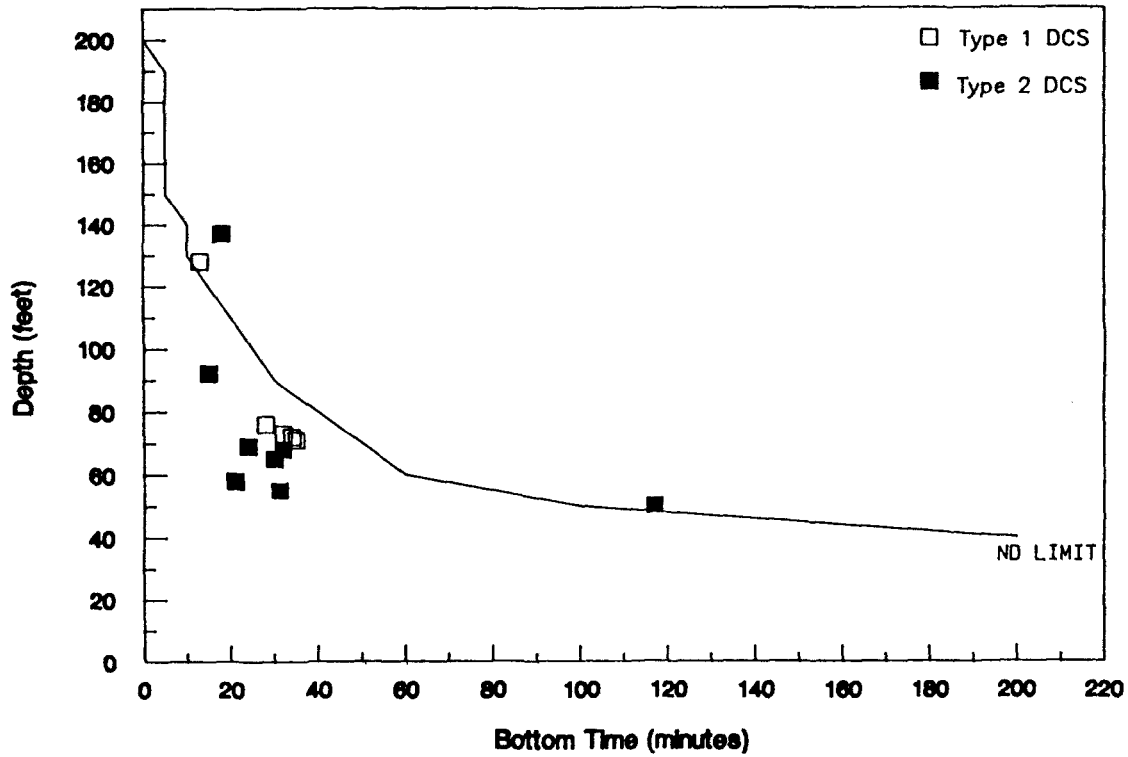

Figure 3. 1986 - 1990 Distribution of total No-D DCS. A number of the Type II's are well inside the limit.

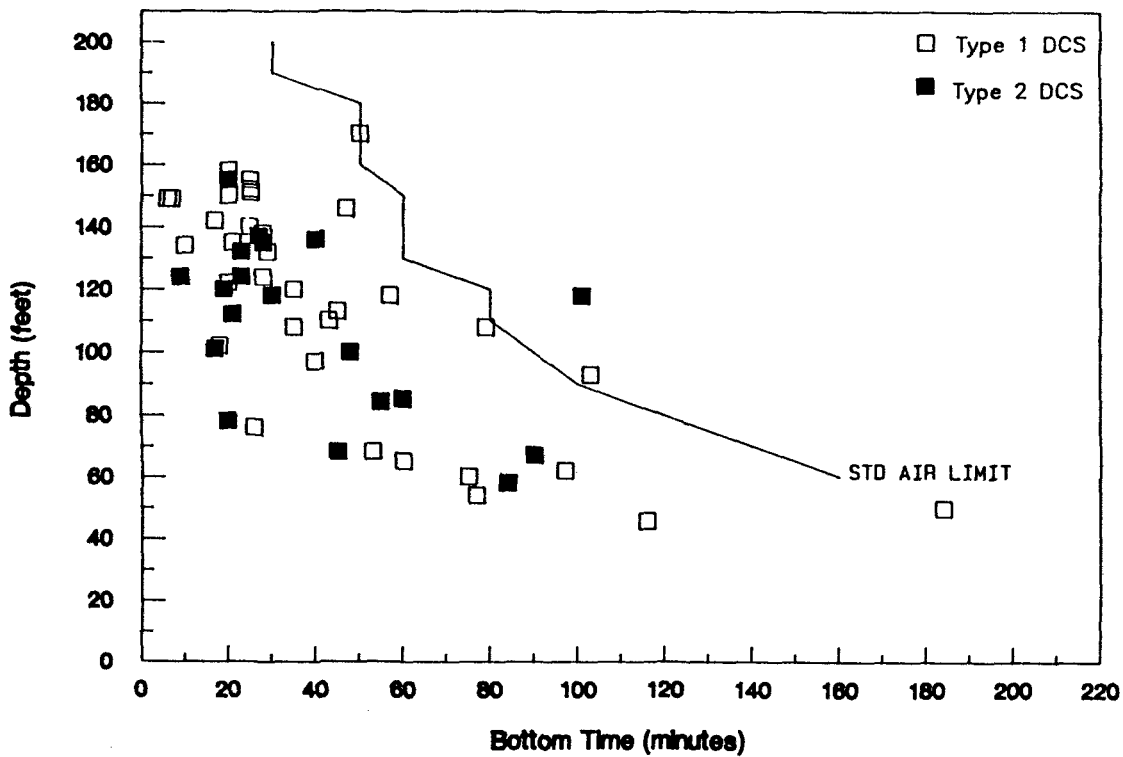

Figure 4. 1986 - 1990 Distribution of total STD AIR DCS for in-water decompression. There are many hits inside the limit, with many Type II's.

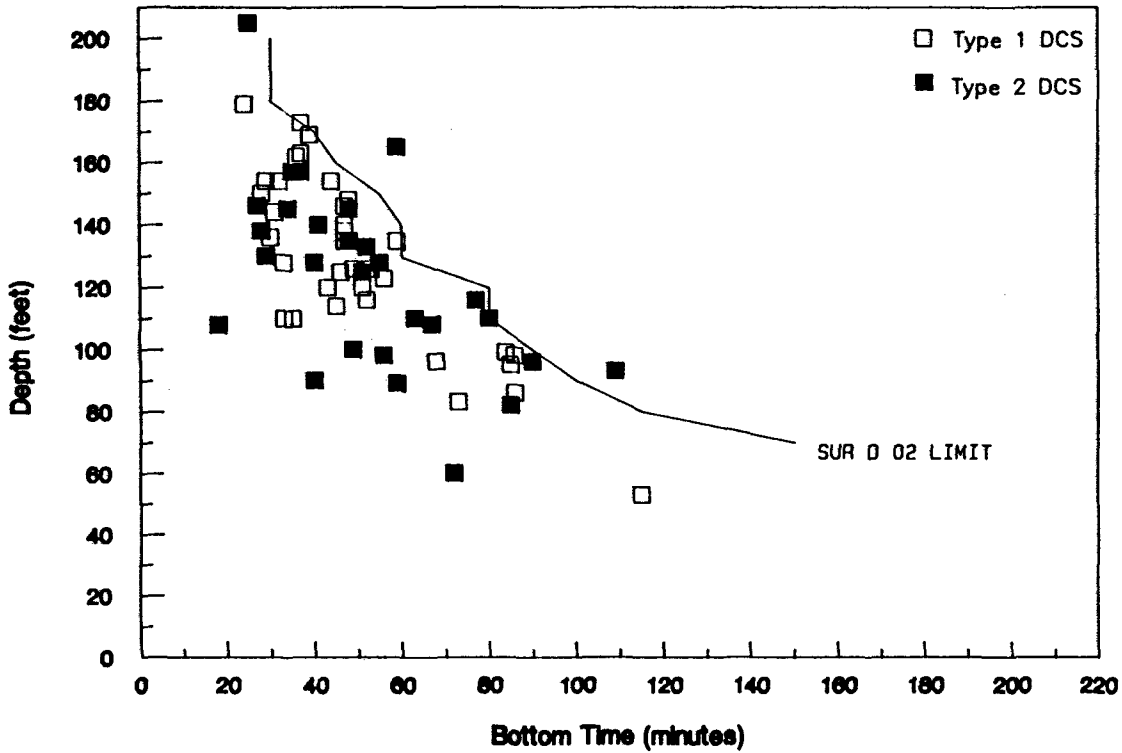

Figure 5. 1986 - 1990 Distribution of total sur-D-O<sub>2</sub> DCS. Most of the hits are inside the limits. These are air dives and not gas or any other type of nitrox. Thought to be a very safe procedure, there still seem to be many hits.

Table 2. Americas Region - Total air dives recorded.

YEAR	TOTAL AIR DIVES	NO DECOMPRESSION	IN WATER DECOMPRESSION	SURFACE DECOMPRESSION
1986	5,019	3,099 62%	364 7%	1,556 31%
1987	5,060	2,808 55%	716 14%	1,536 30%
1988	5,559	2,957 53%	1,545 28%	1,057 19%
1989	5,507	3,166 57%	1,034 19%	1,307 24%
1990	5,151	3,064 59%	889 17%	1,198 23%

**Table 3. Americas Region - Dives per DCS incident.** Infinity = No DCS for that Year. No-D as expected, In-water not so good, with sur-D-O2 improving. Changes in our tables came in 1986. With education and use of the tables with offshore supervisors, our record has steadily gotten better.

YEAR	ALL AIR DIVES	NO DECOMP.	IN WATER DECOMP.	SURFACE DECOMP. WITH O2
1986	1,004	INFINITY	364	389
1987	337	INFINITY	179	140
1988	926	INFINITY	386	1,057
1989	1,377	3,166	1,034	653
1990	5,151	INFINITY	INFINITY	1,198

**Table 4. DCS by type - Americas Region.** \*1988 sur-D air dive hit (not included in the sur-D-O2 column. There are more DCS's in sur-D-O2 even though that only constitutes 25-30% of OI diving.

TYPE	TOTAL D.C.S.(AIR DIVES)		NO DECOM.		IN WATER DECOM.		SURFACE DECOM. WITH OXYGEN	
	1	2	1	2	1	2	1	2
YEAR								
1986	4	1	0	0	0	1	4	0
1987	10	5	0	0	4	0	6	5
1988	5*	1	0	0	3	1	1	0
1989	3	1	0	1	1	0	2	0
1990	1	0	0	0	0	0	1	0

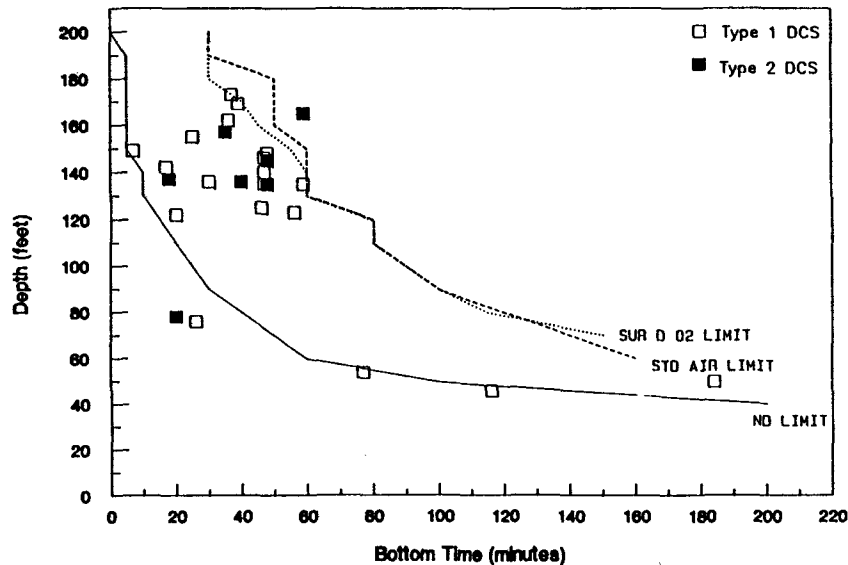

**Figure 6. 1986-1990 Distribution of Americas total DCS by depth and time.** Only a few are over the limits, the rest of are in the deeper, longer time periods.

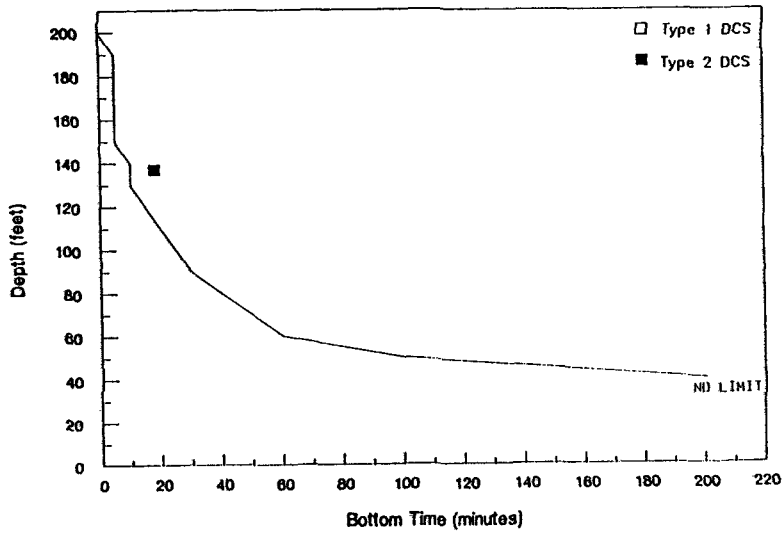

Figure 7. 1986-1990 Distribution of Americas No-D DCS by depth and time. This dive was over the limit, not surprising there was a Type II hit there.

Figure 8. 1986-1990 Distribution of Americas std air DCS in-water decompression by depth and time. All DCS hits are well below the established diving depth/time limit.

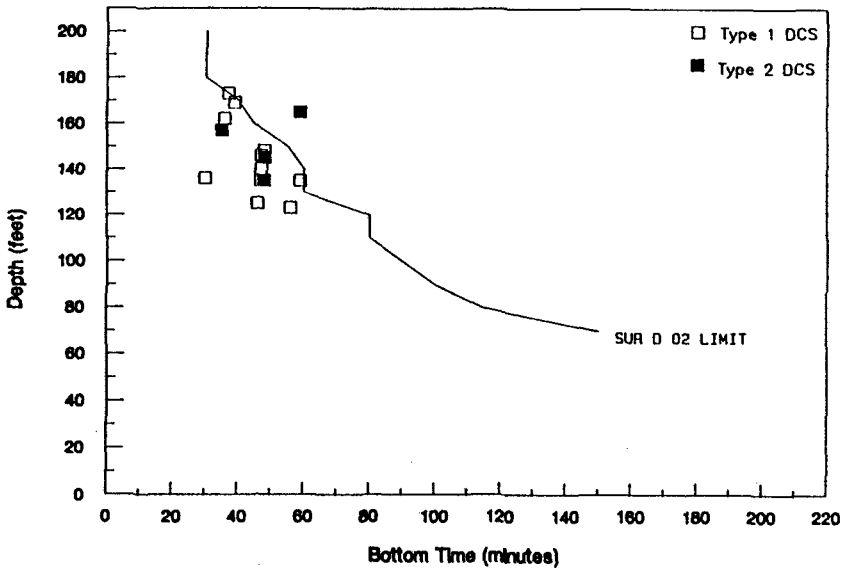
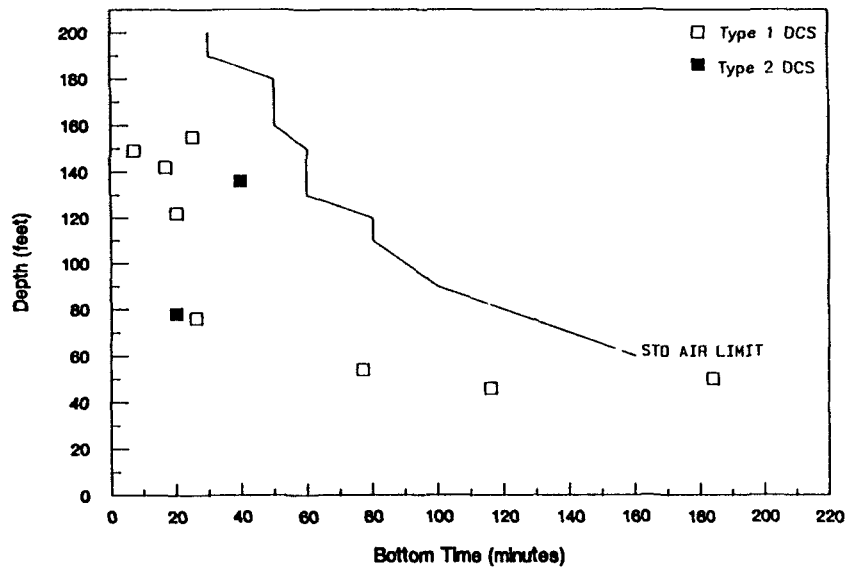

Figure 9. 1986-1990 Distribution of Americas sur-D-O2 DCS by depth and time. Sur-D-O2: > 20% of dives, Repets: 10-15%, most multi-day diving. DCS in the 130 - 170' range near the bottom time limit. These 130' and 150-170' ranges is the table that causes the most problems.

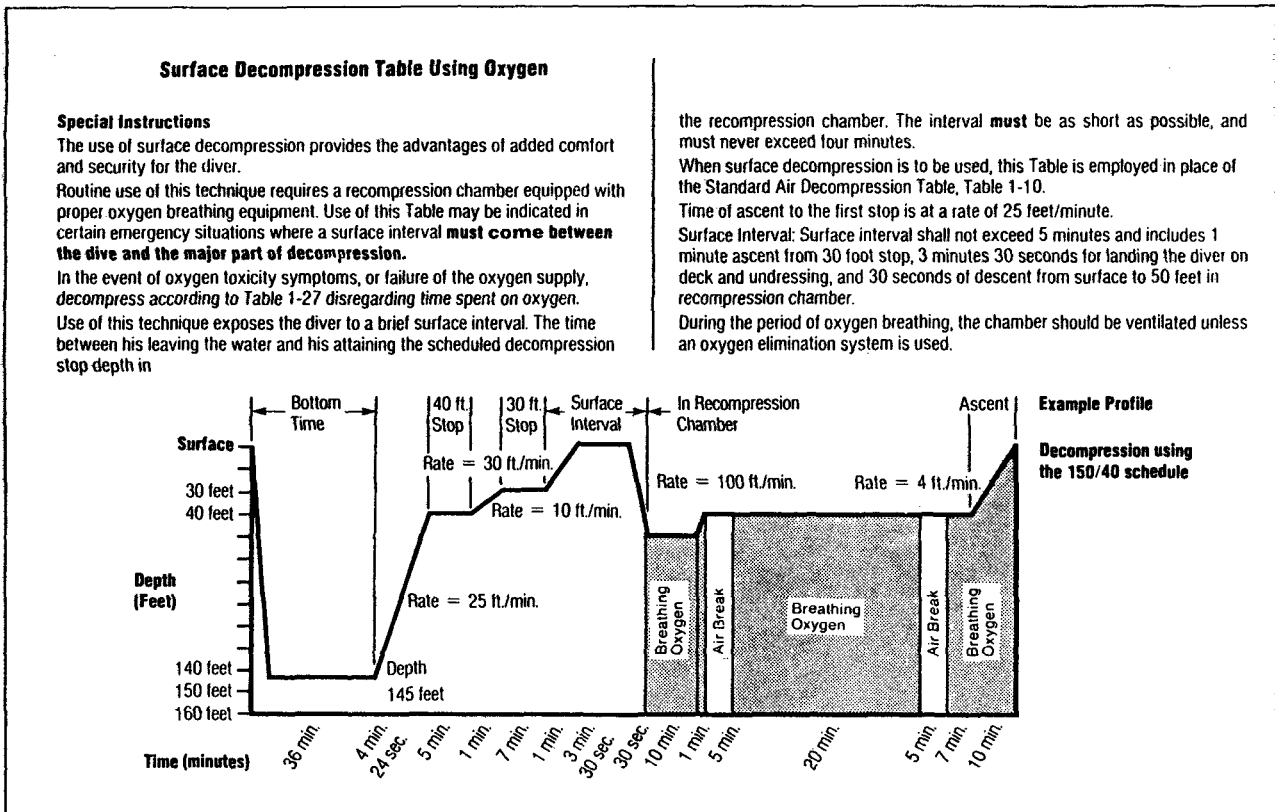

Figure 10. Oceaneering Surface decompression table using oxygen

Oceaneering International surface decompression using oxygen (sur-D-O2) was introduced worldwide in 1985. We tested them in Southeast Asia and the Middle East - due to extreme liability involved in the testing of tables here in the United States - for two years and approximately 20,000 dives. Sur-D-O2 differs from the U.S. Navy in there is always a 3 minute 30' stop, recompression in the chamber to 50' for 10 minutes, going on oxygen as soon as possible, then a one minute ascent to 40' with a 5 minute air break. Cycles of oxygen and air are continued for the time specified in the table on a 20/5 or 25/5 schedule. There is a 10 minute bleed to the surface on oxygen at the end of the 40' stop. We start out with our in-water stops, almost identical to the Navy Tables with the exception that we always have a three minute stop at 30 feet and do not come straight out of the water on sur-D-O2. On any dives below 120 feet or with more decompression obligation than the 3 minute stop at 30 feet, we breathe 50/50 nitrox on those stops. The diver surfaces in one minute, has a 3.5 minute surface interval, on standard Navy Table, a 30 second descent in the chamber. At 50 feet, the diver goes on O2 as soon as possible. We spend ten minutes at 50 feet, a one minute slide up to 40 feet and then continue the decompression with air breathing cycles.

**Table 1-10 U.S. Navy Standard Air Decompression**

Bottom Time	Time to 1st Stop	Decompression Stops (Feet)										Total "D"	Repeat Group						
		130	120	110	100	90	80	70	60	50	40			30	20	10			
30	0:00														0	1:30			
40	1:20														7	8:30	J		
50	1:20														18	19:30	L		
60	1:20														25	26:30	M		
70	1:10														7	30	38:30	N	
80	1:10														13	40	54:30	N	
90	1:10														18	48	67:30	O	
100	1:10														21	54	76:30	Z	
OI Operational Depth/Time Limit																			
110	1:10														24	61	86:30	Z	
120	1:10														32	68	101:30	Z	
130	1:00														5	36	74	116:30	Z

**Table 1-27 U.S.N. Surface Decompression Using Air**

Bottom Time	Time to 1st Stop	Time at Water Stops				Surface Interval	Chamber Stops		Total "D"		
		50	40	30	20		10	20		10	
40	1:20								7	15:20	
50	1:20								18	26:20	
60	1:20								25	33:20	
70	1:10								7	30	45:40
80	1:10								13	40	71:40
90	1:10								18	48	89:40
100	1:10								21	54	101:40
OI Operational Depth/Time Limit											
110	1:10								24	61	114:40
120	1:10								32	68	137:40
130	1:00					5	36		36	74	156:40

**Table 1-26 U.S. Navy Surface Decompression Using Oxygen (OI Modified)**

Bottom Time	Time to 1st Stop	Time at Water Stops					Surface Interval	In Chamber on O2		Ascent	Total "D"
		80	70	60	50	40		30	50		
32	2:24										6:24
60	2:24							10	14		43:24
70	2:24							10	20		49:24
80	2:24							10	25		54:24
90	2:24							10	30		59:24
100	2:24							10	34		63:24
OI Operational Depth/Time Limit											
110	2:24							10	39		68:24
120	2:24							10	43		72:24
130	2:24							10	48		77:24

- \* Total time from last Water Stop to First Chamber Stop not to exceed 5 minutes
- \*\* Ascend from 40' to Surface in 10 minutes at constant rate of 4' per minute. Diver must breathe oxygen during entire ascent

Depth (feet)  
90

**Figure 11. 90 fsw Tables. There is always a 3-minute stop on the sur-D-O2 tables at 30 feet.**

**Table 1-10 U.S. Navy Standard Air Decompression**

Bottom Time	Time to 1st Stop	Decompression Stops (Feet)										Total "D"	Repet Group					
		130	120	110	100	90	80	70	60	50	40			30	20	10		
5	0:00													0	2:30	C		
10	2:20													1	3:30	E		
15	2:20													3	5:30	G		
20	2:10												2	7	11:30	H		
25	2:10												4	17	23:30	K		
30	2:10												8	24	34:30	L		
40	2:00											5	19	33	59:30	N		
50	2:00											12	23	51	88:30	O		
60	1:50											3	19	26	82	112:30	Z	
OI Operational Depth/Time Limit																		
70	1:50											11	19	39	75	146:30	Z	
80	1:40											1	17	19	50	84	173:30	Z

**Table 1-27 U.S.N. Surface Decompression Using Air**

Bottom Time	Time to 1st Stop	Time at Water Stops					Surface Interval	Chamber Stops		Total "D"
		50	40	30	20	10		20	10	
20	2:10							3	7	19:40
25	2:10							4	17	31:40
30	2:10							8	24	46:40
40	2:00				5	19		19	33	82:40
50	2:00				12	23		23	51	115:40
60	1:50			3	19	26		26	62	142:40
OI Operational Depth/Time Limit										
70	1:50			11	19	39		39	75	189:40
80	1:40	1	17	19	50			50	84	227:40

**Table 1-26 U.S. Navy Surface Decompression Using Oxygen (OI Modified)**

Bottom Time	Time to 1st Stop	Time at Water Stops					Surface Interval	In Chamber on O2		Ascent	Total "D"
		80	70	60	50	40		30	50		
11	4:48							3			5:48
25	4:48							3			44:48
30	4:48							3			49:48
35	4:24					2	4				57:24
40	4:24					5	7				67:24
45	4:24					6	9				76:24
50	4:00				2	7	11				86:00
55	3:36			2	5	9	14				101:36

- \* Total time from last Water Stop to First Chamber Stop not to exceed 5 minutes
- \*\* Ascend from 40' to Surface in 10 minutes at constant rate of 4' per minute. Diver must breathe oxygen during entire ascent

Depth (feet)  
150

**Figure 12. 150 fsw Tables.** There are other modifications that have been instituted and not published in the manual yet, but are implemented by direction of Safety Notices to the field personnel. Most important, on all dives of 120 fsw or greater, with more than just the 3-minute stop at 30 fsw, the diver is to breath 50/50 Nitrox mix during the water stop time.

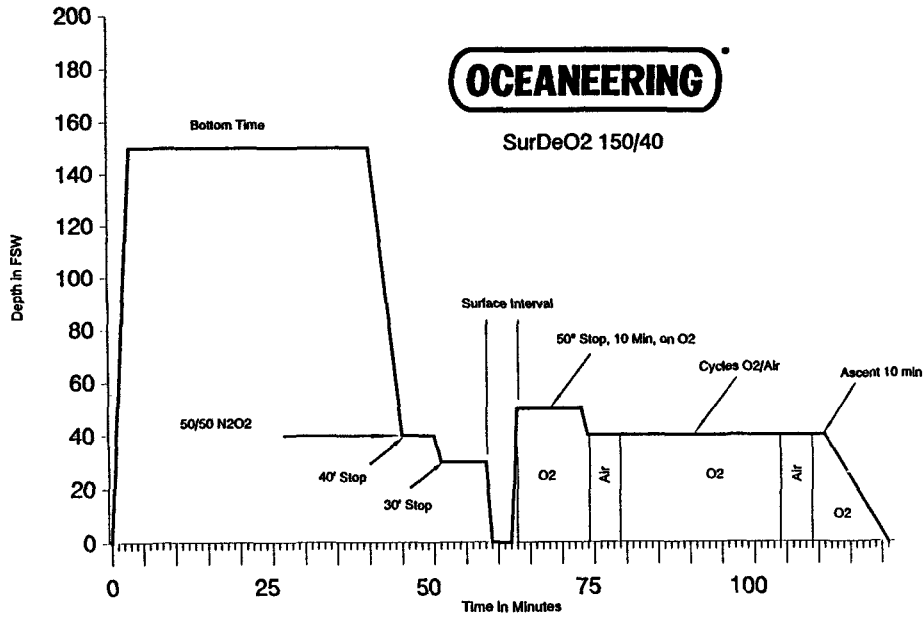

Figure 13. Graphical representation of a 150/40 sur-D-O2 dive. OI instituted a 2-plus-2 rule so the actual dive is only allowed to come within 2 feet and 2 minutes of the depth and bottom limits. We have arranged it so it appears to be an actual square dive. The diver would never make a dive like this. If he was anywhere within 2 feet or 2 minutes of the depth or time, we would move to another table. The diver rises to 40 feet, switches over to 50/50 nitrox, breathes that on the way out, in the last minute or so switches back to air and surfaces into the chamber.

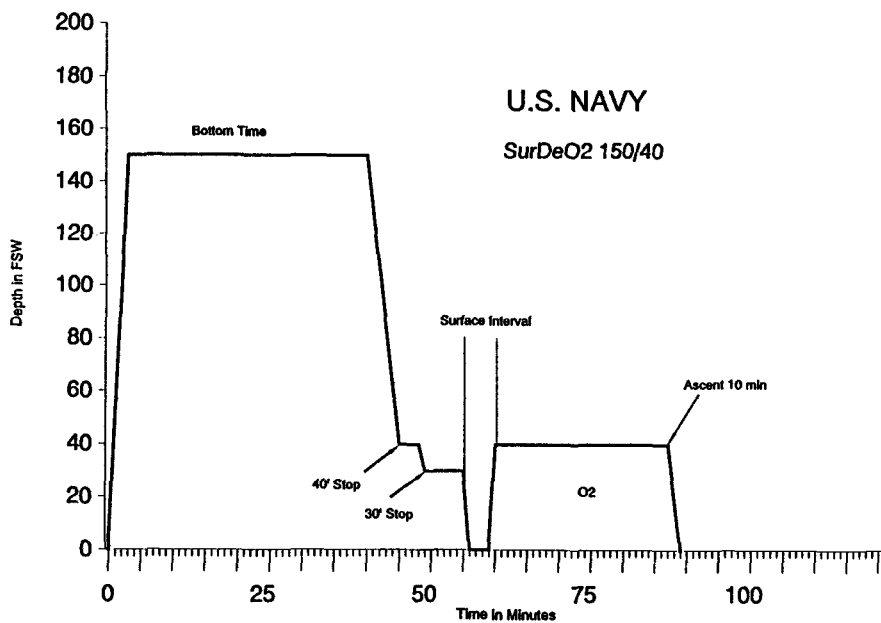

Figure 14. Graphical representation of a 150/40 sur-D-O2 dive on the U.S. Navy table. The Navy table comes out a bit faster and the time in the chamber is a lot less. Since we introduced these tables, decompression incidents have gone from about 1/500 dives to 1/1000 + dives.



**Riser/Repet-Up Procedures**

During operations involving work on riser clamps and non-destructive testing of platforms etc., a single dive may require periods to be spent at a number of depths working up towards the surface.

To decompress from such a dive, some procedures require that the diver is decompressed for the deepest depth achieved during the dive for the total time from leaving surface to leaving the last and shallowest diving depth.

This is completely unnecessary and exposes the diver to excessively long decompression. The assumption is made that the diver is absorbing inert gas from his breathing medium at a rate consistent with being at maximum depth throughout the dive. In fact, the diver has had his inert gas uptake reduced progressively throughout the dive and tissues are decompressing at the shallower working depths.

Riser/Repet-Up Procedures provide the means whereby the inert gas (Nitrogen) uptake may be more accurately assessed and a more appropriate decompression schedule applied.

**Rules**

1. This procedure should only be used when the dive starts at the deepest depth and works upwards towards the surface.
2. When working a diver upwards, his repetitive group shall not extend beyond an 'O' Group.
3. Decompression can be initiated from the final working depth and total residual nitrogen penalty using either surface decompression or in water decompression techniques.
4. Ascent rates between working depths must not exceed 60 feet/minute.
5. After the last (shallowest) working depth, ascent rates are to be in accordance with the decompression schedule selected, i.e. 25 feet/minute for surface decompression using oxygen.
6. Use a minimum repet ascent of 30 FSW between working depths. Any ascent of less than 30 FSW should be considered as time spent at previous working depth.

7. Bottom time for first (deepest) working depth is calculated from leaving surface to arrival at the second working depth.
8. Bottom times for all subsequent working depths (other than the original [deepest] working depth) are calculated from arrival at that working depth until arrival at the next shallower working depth.
9. Subsequent working depths must never be shallower than the first stop of the previous depth/time exposure.
10. Repet-Up Procedure is not to be used shallower than 40 FSW.

Figure One is a worksheet and log to enable this procedure to be easily used. Figure Two is a dive with the following dive profile as an example:

**Dive Profile**

Depth	Time	Ascent to Next Working Depth
158 FSW	9 Minutes	1 Minute (118 FSW)
118 FSW	10 Minutes	1 Minute ( 79 FSW)
79 FSW	9 Minutes	1 Minute ( 43 FSW)
43 FSW	14 Minutes	

While the ascent time between working depths will vary in relation to work of bringing up tools, tigger lines, down lines, etc., for the purpose of this example, ascent time between working depths is taken as 1 minute for convenience.

The procedure is:

Entering the Residual Nitrogen Table at the deepest depth attained during the first phase of the dive and proceeding down the column to the bottom time (including ascent time to next working depth) or the next greater increment and read horizontally across to find the repetitive group:

1. For the initial working depth of 158 FSW for 10 minutes, we use the 160 FSW column and 11 minute increment. This produces a repetitive Group of 'E'.
2. The diver then works for 10 minutes at 118 FSW and ascends to 79 FSW in one minute for a total time of 11 minutes at 118 FSW.

By following the 'E' Repetitive Group line horizontally across the 118 FSW (120 FSW column) we find that the 10 minutes previously spent at 158 FSW is equivalent to 15 minutes at 120 FSW.

The diver therefore carries a 15 minute Nitrogen penalty which is added to the 11 minutes spent at 118 FSW.

By following the 120 FSW down we find the time increment or next greater to 26 minutes (28 minutes). This produces a Repetitive Group of 'I'.

3. The diver works at 79 FSW for 9 minutes and ascends to 43 FSW in 1 minute for a total time of 10 minutes at 79 FSW.

By following 'I' Repetitive Group line horizontally across to 79 FSW (80 FSW column) we find that a residual Nitrogen penalty of 28 minutes incurred at 120 FSW is equivalent to 43 minutes at 80 FSW.

The diver therefore carries a 43 minute Nitrogen penalty to add to the 10 minutes spent at 79 FSW. The nearest increment to 53 minutes is 54 minutes with a Repetitive Group of 'K'.

4. The diver works at 43 FSW for 14 minutes to complete his task and is now ready to decompress to the surface.

By passing horizontally along the Repetitive Group 'K' line to 43 feet (50 FSW column) we find the residual Nitrogen penalty equivalent to 54 minutes at 80 FSW is 99 minutes.

Adding the 14 minutes at 43 FSW to the penalty of 99 minutes (113 minutes) we find the nearest time increment to be 124 minutes with a Repetitive Group of 'M'.

5. On completion of his work at 43 FSW, decompression will be in accordance with 140 minutes (124 minutes residual Nitrogen) at 50 FSW. This requires a 10 minute stop at 10 FSW.

Using the deepest depth for total time principle, this would constitute an exceptional exposure and not be acceptable operationally.

Figure Three is a worksheet for the following series of dives, but decompression on the U.S.N. Surface Decompression using Oxygen Schedule. (OI modified).

**Dive Profile**

Depth	Time	Ascent to Next Working Depth
147 FSW	17 Minutes	1 Minute (115 FSW)
115 FSW	12 Minutes	1 Minute ( 86 FSW)
86 FSW	16 Minutes	

**Figure 15. Riser Repet-up air dive procedure. These are < 5% of dives with no DCS problems.**

DIVE SERIAL NO. 2		RISER/REPET-UP AIR DIVING LOG				DATE 1 September 1985										
CLIENT	VESSEL STRUCTURE	LOCATION	DIVER	MAX. DEPTH	DECOMPRESSION SCHEDULE											
Helburn Oil	Barracuda	Katy	Rogers	147'	USN Sur D O; OI Mod 90/80											
<b>RESIDUAL NITROGEN TABLE</b>																
DIVE DEPTH (FEET OF SEA WATER)																
Repetitive Groups	40	50	60	70	80	90	100	110	120	130	140	150	160	170	180	190
A	7	6	5	4	4	3	3	3	3	3	2	2	2	2	2	2
B	17	13	11	9	8	7	7	6	6	6	5	5	4	4	4	4
C	25	21	17	15	13	11	10	10	9	8	7	7	6	6	6	6
D	37	29	24	20	18	16	14	13	12	11	10	9	9	8	8	8
E	49	38	30	26	23	20	18	16	15	13	12	12	11	10	10	10
F	61	47	36	31	28	24	22	20	18	16	15	14	13	13	12	11
G	73	56	44	37	32	29	26	24	21	19	18	17	16	15	14	13
H	87	66	52	43	38	33	30	27	25	22	20	19	18	17	16	15
I	101	76	61	50	43	38	34	31	28	25	23	22	20	19	18	17
J	116	87	70	57	48	43	38	34	32	28	26	24	23	22	20	19
K	138	99	79	64	54	47	43	38	35	31	29	27	26	24	22	21
L	161	111	88	72	61	53	48	42	39	35	32	30	28	26	25	24
M	187	124	97	80	68	58	52	47	43	38	35	32	31	29	27	26
N	213	142	107	87	73	64	57	51	46	40	38	35	33	31	29	28
O	241	160	117	96	80	70	62	55	50	44	40	38	36	34	31	30
Z	257	169	122	100	84	73	64	57	52	46	42	40	37	35	32	31
DIVING SUPERVISOR	STANDBY DIVER	EQUIPMENT USED		LEFT SURFACE	ARRIVED SURFACE	TOTAL TIME UNDER PRESSURE										
John	Bloggs	Rat Hat Hot Water Suit		0600	0748	108 Mins										
	TIME	DEPTH	BOTTOM TIME	TRAVEL TIME	RESIDUAL NITROGEN TIME	TOTAL DECOMPRESSION TIME	REPETITIVE GROUP									
LEFT BOTTOM	0617	147'	17	1	—	18	'H'									
ARRIVED SECOND WORKING DEPTH	0618	115'			25		'H'									
LEFT SECOND WORKING DEPTH	0630	115'	12	1	25	38	'L'									
ARRIVED THIRD WORKING DEPTH	0631	86'			53		'L'									
LEFT THIRD WORKING DEPTH	0647	86'	16	2:24	53	69	'O'									
ARRIVED FOURTH WORKING DEPTH																
LEFT FOURTH WORKING DEPTH																
ARRIVED FIFTH WORKING DEPTH																
LEFT FIFTH WORKING DEPTH																
WATER STOPS		DECOMPRESSION SCHEDULE			CHAMBER STOPS											
	TIME	DEPTH	MINS		TIME	DEPTH	MINS									
ARRIVED	0649:24	30'	3	LEFT SURFACE	0656											
LEFT	0652:24	30'		ARRIVED BOTTOM	0657	50'	10									
ARRIVED				ON OXYGEN	0700	50'										
LEFT				LEFT	0707	50'	25									
ARRIVED				ARRIVED	0708	40'	5									
LEFT				OFF OXYGEN	0708	40'										
ARRIVED SURFACE	0653:24	REMARKS		ON OXYGEN	0713	40'										
				LEFT	0738	40'										
				ARRIVED SURFACE	0748											

Figure 16. Example profile. This dive profile is 147 feet for 17 minutes. On the table, start at 150 feet, go down to 19 minutes, move to the next stop at 115 feet (i.e., 120 feet with residual nitrogen time 25 minutes). It is very easy for the supervisor to follow. Arriving at the O-line, decompress out on the last stop, in this case 86 feet for 69 minutes, which puts the diver on 90 feet for 80 minutes with the 2-plus-2 rule.

#### Use of Oceaneering Technique for "Hang Off"

This procedure is useful during air diving operations when it is necessary to wait for topside before work can be resumed, i.e. setting anodes when it is necessary to wait for topside rigging, picking up scrap on bottom with crane, etc. **It can only be used when the diver's first decompression stop is 30 feet or less.** With this procedure, the diver can "hang off" at 30 feet for as long as 20 minutes and not have this time count against his bottom time.

##### a) Procedure

1. Diver descends to working depth and works until it becomes necessary to wait for topside support.
2. The diver then ascends to 30 feet at 25 feet per minute – **Bottom Time stops when he leaves bottom** and "hangs off" while waiting for the necessary support.
3. When ready to go back to work, the diver can return to working depth – **Bottom Time starts again when he leaves 30 feet** and works either until the job is finished or it becomes necessary to again wait for topside support. If after 20 minutes at 30 feet, the diver is unable to return to work on the bottom, he must be decompressed on the proper schedule for his original depth and bottom time. If the schedule calls for a 30 foot stop shorter than the time the diver has already been there disregard the 30 foot stop, proceed to the 20 foot stop, and follow the schedule exactly for the remainder of the decompression; if the 30 foot stop is longer than the diver has already been there, complete the stop, and follow the schedule exactly for the remainder of the decompression. If no 30 foot stop is required, proceed to the first stop listed and follow the schedule exactly for the remainder of the decompression.
4. This procedure can be repeated until the accumulated bottom time puts the diver into "O" repetitive group, or for four dives to bottom,

whichever comes first. At that time, he must be decompressed on the appropriate schedule.

5. This procedure can also be used with the Oceaneering "repet-up" technique if the diver goes to work at a shallower depth following the "hang off" at 30 feet. In this instance, he is assigned the penalty for the first working level as described in the use of the repet-up technique.
- 6) Decompression following dives using this technique can be carried out on the U.S. Navy Standard Air Decompression Table or Surface Decompression Table Using Oxygen. Use of U.S. Navy Surface Decompression Table using Air is not authorized except in emergency.

##### b) Repetitive Dives

Repetitive Diving is not authorized following completion of a dive/or dives using this procedure. A surface interval of 12 hours must be observed between completion of decompression following the dive, and the start of the next dive.

##### c) Safety Procedures

1. Diver cannot run past first "O" repetitive group designation.
2. "Hang Off" time is limited to twenty minutes maximum.
3. Number of dives to bottom, including the first one, is four.
4. Work must terminate, and decompression must be started when diver reaches "O" repetitive group designator. Under no circumstances is he to run into "Z".
5. Decompression safety procedures are as outlined on preceding pages for the decompression table in use.

**Figure 17. Hang off procedure.** This is done with <1% dives without DCS incidences. With this procedure, our divers get a bit more bottom time. Instead of sitting on the bottom with nothing to do while they're waiting for a crane line or something, we bring them up to 30 feet, to stop their time. This allows for a total of 20 minutes hang-off time - actually dead time on their dive. They can go to the bottom a total of four times, or up to a repet group O. We do not allow repeats on this type of procedure.

### Conclusion

Over the years, many of the commercial diving companies have modified their tables in one way or another, mostly becoming more conservative. In the future, with some of the work that is being done by Dr. Lambertsen and Mike Gernhardt, we will start evaluating our tables. They will probably be more conservative, coming out of the water a lot faster. Some of the things that we have done in the past to modify our tables and thought were more conservative, have turned out to be the wrong way to go.

Oceaneering International has modified the diving procedures and tables over the years and has reduced the incidence of DCS. We may never realize a zero DCS incidence rate. However, a minimum goal of 1 DCS per 1,000 dives should be attainable, a credible goal would be 1 DCS per 1,500 dives and an ambitious goal of 1 DCS per 2,000 dives would not be unrealistic. With the procedures in use today, these goals are attainable. There is still a need to address physical fitness, the age of commercial divers, limits as to the number of continuous days of diving before a short lay-off, and fitness to return to diving after a serious DCS incident.

**COMMERCIAL DIVING SERVICE, INC.**

*Jon Hazelbaker*  
Commercial Diving Service, Inc.  
PO Box 360568  
Columbus, OHIO 43236 U.S.A.

Commercial Diving Service, Inc. (CDS) employs 7 qualified commercial divers, representing over 100 years of experience. The youngest diver is 25 and has 5 years of experience with this company. The majority of deep diving jobs is accomplished by the older divers, each with a minimum of 13 years experience with CDS.

Although the majority of our work is in 30' of water or less, we do maintain 54" and 48" chamber systems to engage in diving operations to 190'. Inland projects on which we might implement our deep diving techniques are rivers, lakes, reservoirs or industrial sites where underwater work is required for extended periods in water as shallow as 40 feet. Examples from past projects are caisson work for building foundations, water storage tanks, water towers and standpipes, cofferdam excavation, Ranney collector well projects, and water control structures on government or privately controlled reservoirs.

Our deep diving amounts to less than 5% of our total diving operations but is an important extension of our services. CDS still uses the USN Tables with few modifications and has not had the need, demand or resources to change this format to date.

The modifications and procedures we utilize are as follows:

1. On sur-D-O<sub>2</sub>, we use 10 minutes to surface the diver from the 40' chamber stop.
2. On sur-D-O<sub>2</sub> decompression, we utilize 5 minute air breaks every 15 minutes.
3. We perform sur-D-O<sub>2</sub> and repetitive dives with 6 hour minimum surface intervals.
4. On no-decompression dives, we run divers up to 5 minutes of the maximum bottom time including 1 minute for ventilation before leaving the bottom and a safety stop at 10 feet.
5. On dives outside the no-decompression limits we run divers up to 5 minutes maximum bottom time including 1 minute for ventilation and decompress the diver on the next greater time schedule.
6. We never exceed the "O" designation group.
7. When planning sur-D-O<sub>2</sub> we will complete decompression on air in-water when stops do not exceed 14 minutes.
8. We rotate divers to alternate days for surface repet diving.
9. We do not allow flying within 12 hours of surfacing from a decompression dive.

In past years we have run surface oxygen repetitive dives with 3-4 hours surface interval ending the diver with a OO or triple O group and on single dives run the diver to a "Z" group but never on

consecutive days. We have done in-water decompression on oxygen. High altitude dives have been performed to 127' depth at 9700 feet altitude using USN Tables and NOAA depth conversion charts and in-water decompression. We have also allowed flying after diving with a minimum 6 hour surface interval and the diver reaching a "C" repetitive group designation.

As of December 31, 1990, Commercial Diving Service, Inc. has completed a total of 31, 316 dives, 1, 435 of which were decompression dives. To date we have a zero bends incidence record, i.e. no reported or treated decompression sickness. We believe the key to our record is:

- a. Physical fitness of all dive team personnel;
- b. Diver experience, and;
- c. Dive team and procedural continuity.

As we continue to expand our operations and take on younger divers we plan to:

- a. Add another decompression system to our inventory;
- b. Upgrade our in-house training procedures stressing physical fitness;
- c. Implement the training and use of nitrox for decompression purposes;
- d. Hopefully gain the use of safer, proven tables, and;
- e. Most importantly, we will strive to maintain our zero bends safety record.

**Commercial Diving Session Discussion**  
André Galerne, Moderator

- A. Galerne: One of the problems we face in our industry is that ADC has to look seriously at the inland diving sector, in the sense that, in 1990, three divers have been lost in the in-shore diving business where none have been lost offshore. We believe that the improved situation in the offshore industry is due to ADC's hard work in standardization of safety and training. We need that in the in-shore sector and I hope this year we will correct that. We will certainly need your help, gentlemen, because I think three people killed this year is too much. Divers certainly do not have too many problems with the bends because the majority of the dives are in relatively shallow water, but they have more accidents or mechanical problems with the equipment they work with. For example, working in a dam where you have suction, working a pump where your hose is suctioned or a mistake by the crane operator who could drop something on you.
- R. Vann: In the analysis of surface decompression using Tom Shields' method, is the form of the decompression procedure important? If a more conservative procedure was used, would there be less decompression sickness? Should surface decompression be regarded as an entity or should the specific decompression procedure be considered?
- J.P. Imbert: The data I presented are coming from Dr. Tom Shields and the survey considered several diving companies using quite different tables, so the stop time and the recompression time varies with all these tables on recompression. I would be very curious to see how the incidence of using surface-D tables with 15 meters recompression fits on the shifting of the line. But, the variety is built into the result and I do not think that duration of stops matters much in the result.
- J. Lewis: Is it the right interpretation of the data that we are getting one out of 10,000 or less incidence in recreational diving and here one out of 1,000? And, then I heard zero out of 30,000; that is very, very shallow.
- A. Galerne: I think that is correct, yes.
- B. Merriman: That is correct, absolutely.
- A. Galerne: A difference between the commercial divers and the sport divers is the duration on the bottom.
- J. Lewis: With exercise.
- A. Galerne: Under heavy work, yes. In fact, for my company, I prepared no presentation because we use gas mixtures, nitrox from 60 feet down and trimix to 150 feet. But, in our technique of decompression, we request the divers to stop working for the last minute on the bottom, to not move at all and breathe slowly. We estimate that with that procedure, we eliminate 80% of the CO<sub>2</sub> and I believe that the CO<sub>2</sub> is often the guilty gas that provokes the first bubble, whereafter the decompression capabilities are diminished. In our offshore work, when we reach the surface, we go back to 60 feet to treat for five minutes on oxygen and then we go back to the regular table. We have very, very few accidents. On one job in 240 feet of water, we logged 75 minutes on the bottom. For 5,000 dives in 18 months, we have two accidents - two incidents, no choice.
- M. Powell: You had a list of things which your group did to increase safety, like shortened bottom times, 50/50 nitrox and so on. One of those was listed as a reduced surface interval and what is the rationale that reduced surface interval increased the safety?
- J. Hazelbaker: Gary was talking about sur-D-O<sub>2</sub>, at three minutes.
- C. Fife: Did I understand you correctly to say that the surface decompression on oxygen had been banned in France?
- J.P. Imbert: Yes, that is right, it was under the influence of Dr. Fructus in France.
- C. Fife: I understood you to say that surface decompression on oxygen had been banned and I was curious because it looks like we have two different philosophies on either side of the ocean.
- G. Beyerstein: Absolutely, you bet!

- C. Fife: I would like to hear all of your comments regarding the difference between the arguments for oxygen decompression on the surface versus in-water oxygen decompression.
- J.P. Imbert: In 1972-1974, under the influence of Dr. Fructus, the risk was recognized for the high rate of Type II DCS incidence with surface decompressions. Now, with the surface decompression divers rehabilitate and we tend to think that a certain limit is still very safe. It is very clear in the DEO report that if you dive within certain limits, there is no problem at all. I think that is the explanation.
- A. Galerne: That is the difference between one man's decision and a consensus decision. This is why in the United States we do not want to see some people making the decision for us.
- G. Beyerstein: The tables that are in use today, are all basically U.S. Navy Tables or Van Der Aue modifications of the U.S. Navy Tables. Most of them are not even Workman modifications or tables, so they are certainly second, not third or fourth generation tables. They all have an increased penalty as your exposure index goes up. The model does not track and therefore, the higher your exposure index, the more DCS you are going to get. All the Shields reports did was plot those on a scatter graph and draw a line underneath to eliminate all the diving in that higher exposure index. They were left with an exposure index of about 25 which is a very moderate, light exposure dive. Most of the operational planning limits, the first O on the U.S. Navy standard air sur-D-O2 tables, if you carry those groups across, are around 35; as you get deeper, maybe around 38 or so. Those are the kind of exposure indexes that we live with and get acceptable results with. I think Terry has good data that shows that when they put that first limit on which was higher than 25, it shifted everybody over into in-water decompression and when they started running the kind of exposure index dives, duration dives, that they were doing before, their incidence of DCS went up astronomically. So, the next year, the DEO cut that out, too, and what they have started to do now is use 'transfer-under-pressure' diving which involves much more equipment, more personnel on-site. In order to justify that extra expense to the customer, they are doing even further, longer exposures, which gets the exposure index way, way up there and they are having equal problems with that. Therefore, we are convinced from looking at the data overseas and looking at our own experience that it is the quality of the decompression not the decompression mode that counts. We will have bends on any type of mode, whether it is no-D, sur-D-O2 or in-water decompression. But, in-water decompression is by far and away the least desirable of all the decompression modes for our situation here in America, at least, for sur-D-O2.
- C. Fife: This is for operational considerations?
- G. Beyerstein: Operational considerations and also safety considerations.
- P. Heinmiller: As a matter of definition, when you talk about a certain percentage of sur-D-O2 being repetitive, in that repetitive category, you are including both repet-up and surface interval repetitive dives, correct?
- B. Mills: Yes, all the dives that are repet-up and repetitive dives.
- B. Merriman: I think most of us count a repet-up dive as one dive.
- P. Heinmiller: And, most of your repetitive percentages are repet-up which we call multi-level and you do not do a lot of surface interval repetitive dives, correct?
- T. Overland: Absolutely.
- B. Mills: Bob's program, the repet-up on the riser, is a very small number, but it is included.
- B. Merriman: We treat them all the same, but yes, we do repet diving with the surface interval all the time. That is the way that 99% of our dives are done because in a commercial diving job, you really cannot get around it because you cannot carry enough equipment to not do it. If you go out on a boat where you have Coast Guard regulations you are restricted on how many people you can have on-board and you cannot carry a 30 person diving crew, so you have no choice if you are going to do the job.
- P. Heinmiller: So, although you do not have the air limitations that the recreational and the scientific divers typically have, you have other limitations that make you do repetitive work?
- B. Merriman: Yes.

- W. Sutherland: At first, it is alarming that you have one case of DCS in 1000 dives, but the nature of your diving is so different from the recreational or scientific communities. Can you comment on how that one in a thousand compares to other accidents when you are working around all the heavy equipment you have, such as cranes? How dangerous is diving compared to just general, commercial work?
- A. Galerne: Well, I can only say that in my company, in formal lawsuits, we have none that involved divers and a diving accident. They were all related to the surface work. You are safer when you are underwater!
- G. Beyerstein: Fifteen percent of my incidents happen underwater and those are the kind of things that could have happened on the deck. But, most of the incidents, as we track OSHA incident records, all relate to ordinary things that could happen anywhere else in most cases.
- J. Lewis: Did I hear correctly that the majority of you are using the U.S. Navy Tables for the repetitive dive control?
- J. Reedy: No, that is not true. There is no one using the Navy Tables exactly as they are written. That is the basis that we modify from, but there is nobody using them exactly as written.
- J. Lewis: Are any of you willing to say more definitively what you do with respect to repetitive dive control?
- J. Reedy: I thought that was presented.
- G. Beyerstein: Repetitive or repet-up?
- J. Lewis: No, repetitive. Repet-up is a brand new word to me. I have never heard that before. Just repetitive diving followed by some surface interval, what kind of credit are you giving your surface interval?
- T. Overland: Are you talking about the RNT table? I think we use the same RNT table. The nitrogen table is the same as with the U.S. Navy.
- J. Lewis: Residual nitrogen time is based on the U.S. Navy?
- J. Reedy: Yes, we typically only go to an O. We do not have six hours surface interval after divers reach an O. For gas diving, most of us have an 18-hour surface interval between dives.
- J. Lewis: Do you impose any minimum surface intervals?
- J. Reedy: Only in surface decompression, which is five minutes and, in some tables three minutes.
- B. Merriman: Did you mean surface interval between dives?
- J. Lewis: Yes.
- B. Merriman: Six hours minimum.
- J. Reedy: Are you talking about sur-D-O<sub>2</sub> or just any dive?
- B. Merriman: No, sur-D-O<sub>2</sub>. That's what we have been doing.
- J. Reedy: No, I think he was talking about anything.
- J. Lewis: Well, all right, there are two distinctions, between the surface decompression with oxygen and, for example, the no-D which represented a significant fraction of the diving. What about the no-D diving as an example?
- G. Beyerstein: Up and down, just like your scientific diving example of the yo-yo dives.
- J. Lewis: But, within the limits of the U.S. Navy repetitive table?
- G. Beyerstein: Well, within our modified no-D limits.
- J. Lewis: Is that just a reduction of ten feet, 20 minutes at 100 feet as an example?
- G. Beyerstein: It is a reduction of time on every schedule, as far as the no-D time is concerned, but the RNT table is the same.
- J. Lewis: But, if I remember in your case in particular, I saw 20 minutes at 100 feet as the no-D limit for SubSea. Is that what you are referring to?
- G. Beyerstein: Yes.
- D. Dinsmore: Do your companies have any kind of limit on how long a person can continually do repetitive diving? I know you said you stay out until the job is done, but do you have any kind of definitive amount of time that would allow a person to continue diving day after day after day?
- T. Overland: You are talking about multi-day diving?
- D. Dinsmore: Right.



T. Overland: Repetitive diving?

D. Dinsmore: Right.

T. Overland: No.

B. Merriman: We would not stay one day longer than the customer has money!

J. Reedy: There are limits on the per day diving. We limit it to two dives.

T. Overland: We limit our sur-D-O2's to two O dives in a 12-hour period, then 12 hours off.

W. Jaap: You were mentioning physical fitness, do you recommend aerobic type physical fitness, strength training, or do you have a particular feeling about this?

J. Hazelbaker: The management of our company is all over 40 and as a lot of people turn that age, you really start paying attention to your health. We lead by example in our company. All of us over 40 have either personal jogging or weight lifting programs and some type of workout. For everybody in our company, we have yearly physicals and we go beyond even what the ADC requires in their physicals with stress EKG's after age 35, and resting EKG's every year. So, we can monitor everybody's fitness. We kind of shame our guys into shape.

M. Lang: John, you mentioned in-house diver training. In our program at the Smithsonian Institution, we have a fairly low turnover of scientific divers. Once you are employed as a curator, scientists usually stay for the rest of their career. In our diving population, the majority of these people are in the 40 plus range as well. With research time being as expensive as it is, we do not get an inordinate amount of exercise. The years of experience that we hear you mentioning in the commercial diving field, is similar to our population who have been diving for 20-25 years. Nevertheless, if diving skills are not periodically refreshed and updated, years of experience is a relative concept. I agree that the physical fitness aspect as well as the elapsed time since the last logged dive is important.

C. Fife: I am fascinated by your Doppler data because we performed Doppler measurements on a group of five divers in Turkey and found that we had a lot of bubbles. I am curious as to whether that may have to do with our practice of in-water oxygen decompression? In-water oxygen was used by some of your divers apparently, but not all of them. I am just fascinated by the lack of bubbles in these people making these unbelievable dives. I am trying to think of a reason for it in terms of their decompression schedule perhaps.

L. Blumberg: I think that their decompression schedule on the way up was fairly good and additionally, these fellows did work their way up to these deep dives. Who knows if they bubbled at 130 feet five or six weeks ago. They built up some immunity to this. I actually performed Doppler on everybody that came up and of the 17 divers there were only two people that bubbled.

C. Fife: At what intervals did you monitor them?

L. Blumberg: Fifteen minutes, 30 minutes and 60 minutes. If anybody bubbled at 60 minutes, I was going to test them out, but nobody bubbled after 30 minutes.

C. Fife: We found the same thing. Bubbles peaked at an hour and we had to look at least that long, but when I monitor people every day for a month of six days of consecutive diving, we saw a real unpredictable incidence of bubbling. There was a pattern to it and that is very interesting.

R. Vann: Do you have any feel for the ascent rate? You mentioned that the overweight fellow was coming up as fast as he could, but was there any effort to measure ascent rates on the other divers?

L. Blumberg: Apparently, their ascent rate from 200 feet or wherever the mooring was, was fairly rapid because when they hit that line, they had about 1000 or 1500 pounds left and had 70 minutes of hanging they had to do. They all managed to do it. So, their ascent up to the first stop which for most people was 50 feet was fairly rapid and then after that, they followed their computer. Now, whether they jumped from 50 feet to 40 feet or whether they came up slowly, I cannot tell you. But, they followed their computer from that point up.

R. Vann: How did the depth of the first stop compare with the Navy exceptional exposure tables?

L. Blumberg: It seemed to me that they were pretty close to that table all the way along, whether they were using their dive computers or not. In fact, some people did not have a whole lot of confidence

- in their computers, but they used them because they did not have a whole lot of confidence in anything, other than themselves. This one heavy fellow just blew up. Divers said they had to get off the line so he could come up and do his hanging; there are witnesses here as to that effect.
- M. Emmerman: I monitored 16 divers in the water on the ANDREA DORIA and watched their ascent rates. They would come up rather slowly to the first 40 foot stop and that was because they were wearing 200 pounds of gear and these guys were heavy. They would go from the 40 to the 30 foot stop crawling and the 30 to 20 foot stop literally crawling again; 20 to 10 in a crawl and then 10 to the surface, extended, coming from the anchor line to the O<sub>2</sub> spot and then back to the ladder. It was a very gradual lift.
- R. Vann: I would like to poll the panel with my usual question. What do you feel is an acceptable incidence of decompression sickness, understanding that zero is desired? I know you have a certain incidence that you are living with right now. What would you ultimately like to reduce that to?
- T. Overland: One DCS case in a thousand is a goal to reach. One in 1500 is probably a very good goal, and one in 2,000 is going to be excellent. We are prepared to treat DCS on-site so having one in a thousand, one in 1500 or one in every 2,000 is no problem. We treat it right away, usually within seconds of being reported. A quick neurological test and the diver is in the chamber, so I do not think that is any problem.
- L. Blumberg: From a recreational standpoint, the one in 10,000 is admirable. Additionally, most people who have decompression sickness, either Type I or Type II, do pretty well and I do not think that is true in most other injuries that people have in any other recreational activity. So, if you do get decompression sickness, that does not mean that you are going to end up paralyzed. You could be treated with relatively little side-effect, whereas in many other activities, you could be treated but you are going to have sequelae afterwards.
- J.P. Imbert: I would like to say that I think it is extremely important to point out the difference between Type I and Type II, that is Type I can be easily treated. There is nothing remaining from it and you can dive 24 hours after a Type I DCS hit. Type II is quite serious, we should make a difference between the two. The second point is, of course, we are working in commercial diving and when there is a DCS occurrence, it is treated. So, the very important point is we should treat the accidents very efficiently. For Type I, the present rate is about one for 2,000-5,000 dives and for Type II it should be one for 10,000. That is possible using the limitation and bottom time.
- J. Reedy: It is really important to differentiate the type of bends, whether it is Type I or Type II and for pain only cases, one in every 2,000 in the commercial industry is pretty good. As far as approaching zero, until we get some better screening exams and do a little better job on our entry-level people, I do not think we are ever going to get to zero. I am not sure there is an acceptable incidence for Type II. I would like to see Type II zero, but you are always going to have Type I on the diver who may have some physiological problems that have not been identified.
- G. Beyerstein: I would like to see one in 2,000 as an achievable goal for all bends and I would like to see it down to about one in 4,000 for non-deserved bends. Just double those as far as our company's experience where Type II's are 43%, so take that roughly 50/50 to 1/4000 for a Type II. But, I agree with the other people on the panel, a bend is not that serious a thing in the commercial environment where you have a chamber right there, if it is recognized and your people are trained. They must understand that a Type I can mask a Type II and that many Type II symptoms are subtle. If it is perceived, diagnosed and treated correctly, then there is no problem whether it is a Type I or a Type II case. A Type II costs you a little more money for a trip back to the beach and a visit to a neurologist, but it is those deeper, more difficult Type II bends that are causing us problems and that is why we are treating them deeper and having good success with it.
- R. Vann: I believe you said that Type II DCS required treatment deeper than at 60 feet. Give us an example of someone who was not recovering satisfactorily at 60 feet.
- G. Beyerstein: When I was bent, paralyzed from the waist down coming up from a 110 foot sur-D-O<sub>2</sub> to an O group, I never got out of the chamber. They blew me back down and did a table 6 on me. I received relief on the way down, exited and was sitting by the chamber. About five minutes later, I bent down to put my boot on and that is the last thing I remember. I woke up when they smacked my

head against the chamber putting me back in and I underwent table 6-A at that time. But, it is nothing I can give you figures on. If you take a gas dive where a guy makes a 250-275 foot dive and has a bend, I do not believe you are going to get the kind of response at 60 feet that you are going to get if you treat them even deeper than 165, or at least go to 165 on 50/50 at first and see how it develops.

- A. Galerne: I think there is one case in France where a diver, a dentist, was paralyzed after a dive at 180 feet and he has been treated to 165 feet with no progress. They decided to push down to 210 feet and it started to work four minutes later. It is definitely a fact that when you have a case with paraplegia, there is no exact proper depth. On a deep job one needs the chamber capability and the gas mixture necessary to go deeper than 165 foot, which is the old battle. We continue to build the chambers for 165 feet and have a lot of people who are hurt with that.
- G. Beyerstein: Have you checked all your chambers lately? When I checked all of my chambers, I found that all of our chambers were good for a minimum of 300 foot working dives. You just have to make sure your safety valve is all right. I want to emphasize, too, that 50/50 nitrox is very important if you are going to go to 165 feet because you are probably a whole lot better at 60 feet on 2.8 atmospheres than you are at 165 feet on 1.3.
- B. Merriman: I would like to see Type II bends eliminated, zero. But, until somebody comes out with some new tables or some pill you can take that eliminates bends altogether, our goal is just to keep them as low as possible and not play with the numbers.
- R. Vann: Well, if you could revise the tables today and come up with an acceptable incidence, what would that be, given that a further revision of the tables would make them longer?
- B. Merriman: I look at a Type I like the diver with the pocketknife, always cutting his finger and putting a Band-Aid on it. I do not know of anybody who has had any Type I problems that were not resolved immediately, with immediate treatment and the fellow being able to go back to work in 24 hours. Type II, on the other hand, is like the amputation, so if there is any goal at all, let us get rid of the Type II's and just put the Band-Aids on Type I's.
- J. Hazelbaker: We are going to strive to maintain our zero bends record. But, certainly, if we have one in 5,000 or one in 10,000, and especially Type I, that will take me long past my diving career at our rate.
- B. Mills: One in a thousand and maybe it will eliminate Type II bends. We go offshore with all the facilities necessary for immediate treatment of decompression sickness and we would love to see zero bends. However, putting somebody on pure oxygen in the water through a mouthpiece is far more dangerous than a bends case because if you get an O<sub>2</sub> hit with this person, you are going to need another diver because you are never going to get him back. Bends are going to happen. I do not believe zero bends is achievable. But, as long as you carry the proper equipment, the necessary tools and people to treat it and then keep it low - one per thousand, two per thousand - and keep the Type II bends down to zero, you are better off.
- A. Galerne: We have had some incidental accidents underwater. We have developed a technique to bring back the diver feet first, not head first, because if you bring the diver up head first, your gas expansion goes to the mouth and out. If you bring the diver up feet first, the micro-bubble you can still have in the lung will expand and help him to have a dry lung when he reaches the surface. We have had one case where that has worked.
- H. Vidars: Of the type bends that you do treat, what percentage of those cases resolve acceptably and what percent result in ongoing neurological deficits?
- B. Merriman: Over the last three years, all of our Type II's have resolved with no problems. Prior to 1987, before we made these changes and had a two or three percent bends rate, we did have several that did not resolve and consequently caused us great problems. Our incentive was not just purely from the humanitarian standpoint of not having these bends, it was from a legal standpoint too. Most of them have acceptable resolutions. We had only one guy who was questionable in the last ten years who claims to have some minor problems.
- G. Beyerstein: Very few. When you get one, it is so serious because you automatically get a big lawsuit. We got 43 percent (20) Type II hits in the last ten years, and, of those, two that didn't resolve. Each of those two could have resolved had they received what I consider proper treatment. We aim for

and I believe there should be zero sequelae on any bend. I believe that any bend, no matter how it happens can be treated successfully if it is treated right. I firmly believe that.

- J.P. Imbert: Minimizing the time delay between the onset and the treatment of symptoms is extremely important. That depends on how the diver feels the symptoms, how he reports them, how the supervisor understands them and what he decides to do. That is the efficiency of the treatment. The COMEX tables use recompression for 30 meters, oxygen briefly, two bars on 50/50, helium gas switch using heliox, 50/50 and drug adjunctive therapy that should treat the problem. But, it is a long chain of events and the result may vary from case to case.
- P. Bennett: I am interested in the difference between recreational diving and commercial diving because one in one thousand seems to be very clear and we are getting two in 10,000 in the recreational community. In the treatment situation, we have got 14.7 percent residuals three months later in Type II only. Then you have Type I where it is about 14 percent. That is because there is terrific delay in treatment. I am impressed by what I am hearing from you in that you give the therapy rapidly since you have the treatment chambers right overhead, whereas these people reporting up to 96 hours after the event then have residuals. We are trying to educate, not enforce, divers in the recreational field that they have got to recognize symptoms and come to therapy very quickly in order to get the kind of data that you are presenting to us.
- T. Overland: Some of those residuals that we have in commercial diving are so minor that if it was in a scuba diver and his motivation was to go back and scuba dive, nobody would ever see them. Our residuals become lawsuits.
- G. Beyerstein: We need perfect treatments, zero residuals.
- R. Eckenhoff: I have to take exception to the comments that these bends are treatable and curable. And, that an absence of a cure represents a problem of treatment around the world.
- G. Beyerstein: Let me qualify it first. When I said that, what I meant is the situation where I have a diver come up and have a bend right here, on-site under control. If you are talking about any other situation, obviously that statement would have to be withdrawn.
- R. Eckenhoff: Well, I would even take exception to that. I think that once you have symptoms, especially Type II symptoms, spinal cord symptoms, you have already demonstrated that you have an ischemic insult to neurologic tissues. Even if you then could somehow magically remove all gas phase, and all the other things that go along with this gas phase, you are still left with the fact that you have an ischemia of the tissue which has to be reperfused. This is something that is well-known in the literature for ischemia reperfusion injury which then proceeds completely independent of the gases, and, in fact, appears it may make this injury worse. So, I just take exception based on theoretical grounds right now that even a very rapidly identified and treated spinal cord injury may not, in fact, be as treatable as one thinks and one still may have to rely on long-time recovery.
- G. Beyerstein: No, I would still maintain my position. The degree of insult is related to the duration of hypoxia and if you eliminate that, as some of the new methyl prednisolone studies show, I believe proper treatment will cure any bend if you have the training and if you have the treatment.
- M. Emmerman: In research that I have done with commercial and military flight crews, I found a great tendency on the part of these people to deny that they have a problem so that they can stay on flight line and keep their income. What happens to the folks in your universe pre-hit or after admitting a hit, to admitting to a residual? How do you deal with this?
- G. Beyerstein: Training! Training! Training!
- J. Reedy: About five years ago we had a workshop that was attended by several members from Duke University. We agreed to allow divers with a Type I bend that was successfully treated to return to work in 24 hours. That encouraged them to report their symptoms. Prior to that, if they knew that they had to leave the job or were going to be restricted from diving, it was much more difficult to get them to report their symptoms.
- G. Beyerstein: Additionally, our whole treatment protocol gives a bonus for somebody who reports early and gets instant resolution. The longer you wait, the more treatment you get and you are going

to get a test of pressure no matter what. If you report and it is judged negative, you are still going to spend some time under pressure, so you might as well report early and get minimum treatment. It seems to work. We have become so hypersensitive in our company now that they report things that are not bends. We get tendonitis that actually resolves under pressure and comes back when it comes up, you know, and a few MRI's and a dozen doctor visits later, the doctor says, "It was tendonitis!"

- K. Huggins: What kind of training program do you have for your divers in the recognition of decompression sickness symptoms and would that type of training be applicable to transfer to the recreational community to help raise their knowledge level as to what is a potential problem?
- J. Reedy: All divers coming to the industry now, are graduates of an accredited diving school. They also get weekly and monthly training sessions from the company and that is one of the subjects stressed. Do you do that with the civilian diving community? I do not know how much they stress that in the PADI or NAUI courses.
- G. Egstrom: In the mechanics of decompression sickness you have a bubble and a lesion in that tissue. Are you saying that once the bubble is gone, the lesion does not create a problem?
- G. Beyerstein: No, I am not saying that. I am saying that if you get the right treatment immediately, you are not going to have any significant symptoms or sequelae.
- J. Reedy: Gary is saying that in our type of work, using the tables that we use now and the diving procedures we have in place, anything that we would expect to see we would expect to be able to treat without any problems. That is not saying that every case is decompression sickness. I am not saying that.
- G. Beyerstein: No, I am not either. That is why I qualified that statement earlier by saying on-site.
- C. Lehner: Are all commercial divers screened for long bone necrosis?
- G. Beyerstein: Initially and that is about it. Anytime they go to a new company they usually get one. We used to do it every three years and we dropped it.
- L. Blumberg: I can comment on that as part of a study I did at the University of Maryland. The interest I have in hyperbarics is related to Orthopedics. Anyone who was a long term diver that came there for any reason, I tried to get studied for a vascular necrosis through any method you might want to use. There was evidence of some elements of a vascular necrosis in their hips and in their shoulders. It may not be severe, but it was already there and those were only 10 or 12 divers that I was able to do that on, but they all had it. Those were commercial divers that had been diving for many years.
- T. Overland: We have not seen that. We do an initial long bone on the diver's physical. Whenever we get somebody from another company, if they have not had a long bone within six months or so, we do another one and we have not found any.
- L. Blumberg: You will not see it on a plane x-ray for years.
- A. Galerne: Alcoholism can also produce those bone necrosis problems.
- L. Blumberg: Right, and they do drink a lot.
- T. Overland: I am talking about divers that have been diving for ten years and we picked up from another company and have never found it in their bones.

## DIVE COMPUTERS AND MULTI-LEVEL, MULTI-DAY REPETITIVE DIVING

*John E. Lewis*  
4524 Palos Verdes Drive E.  
Rancho Palos Verdes, CALIFORNIA 90274 U.S.A.

*The performance of available dive computers is emphasized towards no-decompression, multilevel, repetitive, multi-day diving. The underlying theory and performance tests are described. The majority of dive computers are found to allow full credit for multi-level diving within their respective no-decompression limits; limits that can vary by as much as a factor of two. Repetitive dive control can also be quite different, with the greatest differences found for deep repetitive diving followed by short surface intervals. Finally, the need for special consideration for multi-day diving and the role of dive computers is addressed. Throughout, the data base suitable for validation is presented where it is available and identified as lacking when it is not.*

### Introduction

In September 1988, the American Academy of Underwater Sciences (AAUS) held the first workshop on dive computers at the USC Marine Science Center on Santa Catalina Island. At that time there were more than 20 acronyms used to describe these devices, and it was at this meeting that the term "dive computer" was adopted; a term that is now universally accepted. Not only is the name "dive computer" common, but so is its use by recreational divers. At DEMA 1991, one could choose from over 20 different dive computers, and one out of three new divers choose dive computers over conventional gages.

The increasingly common use of dive computers coupled with the number of divers choosing to vacation on live-aboard dive boats has radically changed the typical recreational diver's diving profile. The days of a single tank dive off the beach on a weekend has been replaced by 4 and 5 dives per day for 7 to 10 days in a row. On top of this, the majority of these dives are no-decompression multi-level dives that frequently have maximum depths in excess of 100 feet and bottom times that approach one hour.

In light of this fast-paced evolution, it is appropriate that we review those dive computers that are presently available. The specific objective of this paper is to characterize their performance in a multi-level, repetitive, multi-day diving environment. In addition, the data base suitable for validation is presented where it is available and identified as lacking when it is not.

### Dive Computer Algorithms

It is difficult to discuss the performance differences of the various dive computers without some understanding of their algorithms. Therefore, the following brief introduction to decompression theory is included.

The decompression theory that was originally proposed by Haldane, the basis of all dive computers distributed in the U.S., consists of two important concepts:

1. The decompression status of a diver requires the monitoring of the nitrogen loading of a number of tissues or compartments.
2. Each compartment is characterized by a different half-time and a different level of nitrogen loading that can be tolerated at atmospheric pressure, *i.e.*, when the diver is on the surface following an exposure at depth.

The term compartment is used in place of tissue to emphasize that while the model does a good overall job, the direct connection between the human body and the model is considerably more tenuous. Haldane's original model had 5 compartments with half-times of 5, 10, 20, 40, and 75 minutes. The U.S. Navy changed the 75 minute half-time to 80 minutes and added a sixth compartment with a 120 minute half-time. Modern dive computers have between 6 and 12 compartments, with half-times as large as 480 minutes.

Nitrogen loading is best explained by example. First, by definition the nitrogen loading of a diver who has not been in the water for a long time is zero. In other words, a "clean" diver has zero nitrogen loading for all compartments. Second, if a diver stays at a particular depth for an indefinite period of time, the nitrogen loading of all compartments eventually saturate at this depth. For example, if the diver enters a habitat at a depth of 40 feet and stays there for an extended period of time, all of his compartments will reach a nitrogen loading of 40 feet (an abbreviation for 40 feet-of-sea water, a unit of pressure). Haldane's theory was originally described in terms of the absolute value of the partial pressure of nitrogen. Nitrogen loading as it is defined herein is mathematically equivalent and considerably easier to deal with.

In order to predict how the nitrogen loading evolves with time, we need to understand the concept of half-times. Consider the habitat example at 40 feet and a compartment with a half-time of 5 minutes, hereafter referred to as the 5 minute compartment. Initially (zero bottom time), the compartment loading will be zero, and eventually the nitrogen loading of all compartments will saturate at 40 feet. What happens in between is governed by the half-time. At a bottom time of 5 minutes, the nitrogen loading of the 5 minute compartment will be one half the difference between the initial loading and the saturation depth or  $(40 - 0) / 2 = 20$ . After an additional 5 minutes (10 minute bottom time), the remaining difference will be halved again, and the nitrogen loading becomes  $20 + (40 - 20) / 2 = 30$ . For all practical purposes, any given compartment is fully saturated after 6 half-times.

There is no theoretical basis for the allowable nitrogen loadings of the various compartments. These must be derived from experimentally determined no-decompression (NoD) limits, *i.e.*, the allowable bottom time at a particular depth that permits a diver to make a direct ascent to the surface. Once these times are determined, they are readily translated into allowable nitrogen loadings of the various compartments of the decompression model. These allowable nitrogen loadings are mathematically equivalent to the "M-values" introduced by Workman to construct the U.S. Navy Dive Tables. Both are elements of decompression theory that are derived from NoD limits that in turn have been validated by human testing.

### Multi-level Diving

Intuitively, one expects to have the NoD time increase as depth decreases so long as a NoD limit has not been reached. What is not clear is the penalty for having spent the initial portion of the dive at a greater depth, and what is neither clear nor intuitive is that one can reach a NoD limit at the initial depth and still have NoD time remaining at a shallower depth. The answer lies in the recognition that only one compartment ultimately controls the total bottom time and the experimentally determined depth dependence of the NoD limits.

For a given compartment, the nitrogen loading acquired at two different depths is approximately the same provided that the product of the depth and bottom times are an invariant, *i.e.*,  $D_1T_1 = D_2T_2$

(see Appendix A). It follows that the Equivalent Nitrogen Time (ENT) at the second depth of a multi-level dive  $ENT_2 = D_1 T_1 / D_2$ . Consider the example of 10 minutes at 100 feet followed by a stop at 50 feet. The  $ENT_2 = 100 \times 10 / 50 = 20$  minutes, and for a NoD limit of 70 minutes at 50 feet, an additional 50 minutes of NoD bottom time is permitted. If the initial stop had been to the NoD limit of 20 minutes at 100 feet, the  $ENT_2 = 40$  minutes, and an additional 30 minutes of NoD time remains in spite of the fact that the NoD time had been exhausted at 100 feet. If the experimentally determined NoD times had turned out to be inversely proportional to depth, multi-level diving would not be permitted once a NoD limit had been reached at any depth.

The most important contribution of a dive computer to recreational diving is its ability to predict the decompression status of a diver performing a multi-level dive, and all "Model Based" dive computers (Loyst *et al*, 1991) allow full credit for a stop at a second shallower depth. This is in contrast to a dive table or a "Table Based" dive computer, which uses maximum depth to determine the total bottom time. A diver using a table or a Table Based dive computer who attempts the multi-level dive described above will find himself on the boat after 20 minutes, while his fellow divers equipped with Model Based dive computers enjoy an additional 40 minutes or more of bottom time.

It is a simple matter to determine if a dive computer is Table Based. Take it to its NoD limit at any depth, but preferably 100 feet or more for the most dramatic effect. When the display first indicates zero NoD time remaining, begin your ascent. As you ascend, monitor the NoD time remaining as the depth decreases. A Model Based dive computer will indicate more or less continuously increasing NoD time as the depth decreases. In contrast, a Table Based dive computer will either remain fixed at zero NoD time remaining throughout the entire ascent or possibly even indicate a small decompression obligation as the ascent progresses.

With the exception of two Table Based dive computers (Suunto USN and Seiko Scuba Master), all of the dive computers presently distributed in the U.S. are Model Based and provide full credit for multi-level diving. That is not to say that their performance will be the same. On the contrary, there are major differences in performance, but these differences are solely a result of the different NoD limits of the various dive computers.

Huggins (1983) and Powell (1987) defended the validity of the concept of multi-level diving through Doppler monitored experiments.

### NoD Limits

Prior to the introduction of the dive computer, the U.S. Navy dive tables were used by both scientific and recreational divers, and, one might add, with considerable success. Spencer's (1976) Doppler experiments indicated that taking these tables to their limits produced considerable bubbles, and he recommended a modest reduction in the NoD limits that approximately amounts to using the bottom times for the next greater depth; an admonition that sounds remarkably like the Navy manual itself. Regardless, it is important to note that both Huggins and Powell used Spencer's reduced NoD limits for their multi-level tests, *e.g.*, 20 minutes at 100 feet. Given the success of these tests, it is at first glance surprising that there is such a wide range of NoD limits used in the various dive computers.

In order to avoid numbing lists of numbers, the dive computers have been divided into three groups: USN, Spencer, and Bühlmann (Lewis and Shreeves, 1990). The groups of dive computers with their NoD limits at 100 feet quoted as an indication of their degree of conservatism are listed below:

USN (24 to 25 minutes) is a group of two:

- Suunto USN
- Seiko Scuba Master



**Spencer** (19 to 20 minutes) is by far the largest group with:

- Oceanic Datamaster II, Datamaster Sport, DataMax Sport, and DataMax Pro
- Orca Edge, Skinny Dipper, and Delphi
- Sherwood Source
- Suunto SME-ML and Solution
- U.S. Divers Datascan 2 and Datascan 3

**Bühlmann** (12 to 15 minutes) includes:

- Beuchat Aladin and Aladin Pro (15 minutes)
- Dacor Microbrain Pro (12 minutes)
- U.S. Divers Monitor (15 minutes)

[The Tekna Computek, which is based on a design by Max Hahn, has not been included because it was not available when the testing was performed in the summer of 1990. However, I am advised (Coley,1991) that it incorporates even lower NoD limits, e.g., 9 minutes at 100 feet.]

### Repetitive Diving

Repetitive diving is a term that is commonly used to denote multiple dives performed during one day. For over 35 years, the U.S. Navy repetitive dive tables were the standard for repetitive recreational diving in the U.S. These tables are based on a 120 minute halftime, a fact that you can readily test for yourself. Go into the repetitive dive table and select any depth for your next dive and any Group, which itself is a combination of an initial Group and some surface interval. Note the Residual Nitrogen Time (RNT), and then advance the surface interval by 2 hours. In general, you will find that the RNT is reduced by approximately one half (see Appendix A). Some examples will work better than others, but this rule is a very good approximation that allows anyone to test the basis of these or any other dive tables, e.g., the PADI Recreational Dive Planner, which is based on reduced NoD limits and a one hour halftime.

Example: U.S. Navy Repetitive Dive Tables

Initial Group L plus Surface Interval of 2 hrs 20 minutes produces Group F			
Surface Interval of 4 hrs 36 minutes (+2 hrs 16 minutes) produces Group C			
Second Depth	60 feet	80 feet	100 feet
RNT Group F	36 minutes	28 minutes	22 minutes
RNT Group C	17 minutes	13 minutes	10 minutes

You can test your dive computer in a similar way, but be prepared for a more complicated picture because the repetitive dive control of dive computers is, in general, based on more than one halftime. Nevertheless, there are three Groups that are readily distinguished from each other: EE Model, 60 minute, and 120 minute (Lewis and Shreeves, 1990).

The term EE Model, Thalmann (1984), denotes a model that predicts that nitrogen is eliminated during a surface interval at the same rate as it was absorbed. For repetitive dives deeper than 120 feet, this can mean that the RNT is reduced by one half in as little as 5 minutes, and a total loss of useable memory will occur in less than 30 minutes!

The 60 minute designation refers to dive computers that restrict the elimination rate to be no greater

than that of a 60 minute halftime, *i.e.*, a minimum of one hour to reduce the RNT by one half. The 120 minute designation applies to dive computers that restrict the elimination rate to be no greater than that of a 120 minute halftime, *i.e.*, a minimum of two hours to reduce the RNT by one half.

EE Model

- Beuchat Aladin and Aladin Pro
- Dacor Microbrain Pro
- Orca Edge, Skinny Dipper, and Delphi
- Suunto SME-ML
- U.S. Divers Monitor

60 Minute Model

- Oceanic Datamaster Sport, DataMax Sport, and DataMax Pro
- Sherwood Source
- U.S. Divers Datascan 3

120 Minute Model

- Oceanic Datamaster II
- Suunto USN
- U.S. Divers Datascan 2

**Repetitive Dive Performance**

Specific examples of Doppler monitored repetitive dives that were successfully tested by Powell and the performance of dive computers tested by Lewis and Shreeves (1990) are presented below.

Shallow Repetitive NoD Dives

55 feet NoD-----57 minute surface interval-----55 feet NoD

Dive Computer	1st Dive	2nd Dive	Total Bottom time
Powell Test Data	65 min	43 min	108 min
EDGE	62	45	107
Skinny Dipper	62	45	107
SME-ML	59	45	104
DataMax Sport	64	40	104
Datamaster Sport	61	39	100
Aladin	51	41	92
Microbrain Pro	51	38	89
Monitor	51	35	86
USN	59	7	66
Datascan 2	57	5	62

Moderately Deep Repetitive NoD Dives

130 feet NoD-----43 minute surface interval-----90 feet NoD

Dive Computer	1st Dive	2nd Dive	Total Bottom time
Powell Test Data	12 min	16 min	28 min
EDGE	10	23	33
Skinny Dipper	10	23	33
SME-ML	10	22	32
DataMax Sport	10	17	27
Datamaster Sport	10	16	26
Monitor	9	17	26
Aladin	7	19	26
Microbrain Pro	8	15	23
Datascan 2	5	14	19
USN	9	9	18

The following repetitive dive schedule, tested by the Royal Navy (Leitch and Barnard, 1982), produced one case of decompression sickness (DCS) following the second exposure and numerous aches and pains after the third.

Deep Repetitive NoD Dives

150 ft for 5 minutes--60 min. surface interval--150 ft for 5 minutes--60 min. surface interval--150 ft for 5 minutes

None of the Oceanic units allowed the second dive, nor did the Sherwood Source, U.S. Divers Datascan units, or Suunto USN. All of the EE Model dive computers that were tested by Lewis and Shreeves allowed all three NoD dives, with some allowing as many as six NoD dives to a depth of 150 feet in a total *elapsed* time of less than 2 hours! (Edmonds, 1988).

**Repetitive Dive Performance Summary**

With the exception of the 120 minute models, the repetitive performance of all of the dive computers for relatively shallow depths appears to be simply a reflection of their NoD limits and are within tested limits. For repetitive dives at intermediate depths, the Spencer-EE Models are modestly above the tested levels, and somewhat surprisingly the Bühlmann-EE Models and the Spencer-60 minute Models are remarkably similar and close to the limits tested by Powell.

All dive computers that are based on a EE Model will allow numerous unrestricted (zero RNT) deep repetitive dives following surface intervals of less than 30 minutes; a test that a diver can readily check for himself by watching his pre-dive scroll for repetitive depths in excess of 120 feet following any deep dive.

**Multi-day Diving**

Multi-day diving is an increasingly common practice and of legitimate concern. However, the present data base is not sufficient to come to an unambiguous conclusion. There are data (DAN) that indicate that decompression accidents occur more frequently on the 3rd day of diving or beyond, but an equally probable interpretation is that divers are simply more cautious on the first day. Without detailed information regarding the actual diving profiles, no firm conclusion can be drawn. The

controlled multi-day testing recently completed by Dr. Powell, showed no increase in Doppler monitored bubbles for up to 4 days of diving 4 dives per day.

Regardless of the ultimate outcome, this is the issue that is most frequently cited as the reason for a dive computer having long halftimes, and it is rigorously true that a 480 minute halftime can indeed have a memory approaching 48 hours. However, the memory is largely useless, and you can prove this by the following experiment:

1. You must be in a multiple day diving situation, and the most convenient is a live-aboard dive boat expedition;
2. Record the clean pre-dive NoD limits of all of the dive computers on board before the diving begins. If you are less ambitious, limit the exercise to your own;
3. Each day repeat the pre-dive scroll and record the new NoD limits just prior to the first dive of the day and;
4. Do this every day, and when the trip is completed, note any differences as a function of depth and day, but don't be too surprised when the differences are nil.

Despite the theoretical 48-hour memory, the practical impact of dive computers on multi-day SCUBA diving is at best uncertain. Even under the most strenuous multilevel repetitive diving, the next morning's pre-dive scroll rarely indicates any useable memory. At most, modest reductions in NoD time at depths of 40 feet or less are indicated, and these are well beyond the limits of SCUBA.

It is possible that even small residuals in slow compartments may effect multilevel diving as a result of the previous day's exposure, but there is no data that validates the hypothesis that dive computer models provide adequate controls for multi-day diving, if indeed they are necessary.

### Summary

Dive computers are the most accurate means of determining the decompression (or no-decompression) status of a diver that is possible, and if their growing popularity is any indication, by the year 2000, only "mossbacks" will be diving without one, and they will be few and far between.

Beyond accuracy, multilevel diving is their most important contribution, and most dive computers provide full credit for multilevel diving. Sixty minute bottom times for NoD dives with a maximum depth of 120 feet or more are commonplace. The experiments of Huggins and Powell coupled with the increasingly common experience of divers in the field provide ample validation of the practice. Dive computers have a surprisingly wide range of NoD limits, and this has a direct impact on their multilevel diving performance.

At shallow repetitive depths, the performance of the various dive computers is primarily a result of their various NoD limits, and all are conservative (the 120 minute Models overly so) relative to the relevant data base.

For intermediate repetitive depths, the Spencer-EE Models modestly exceed the limits tested by Powell, with the rest remarkably close to each other and the test data.

For depths greater than 120 feet, the EE Models commonly lose their useable memory within a surface interval of less than 30 minutes. Common sense coupled with the Royal Navy experiments noted by Carl Edmonds indicate that this is not valid, and divers using dive computers that have EE Models would be well advised to second guess their predictions for deep repetitive diving, particularly with short surface intervals. In point of fact, repetitive multilevel diving to depths in excess of 100 feet has not been validated and as such is best avoided.

Despite the theoretical 48 hour memory, the practical impact of dive computers on multi-day SCUBA diving is at best uncertain. It is possible that small residuals in slow compartments may affect multilevel multi-day diving, but there is no data that validates the hypothesis that dive computer models provide adequate controls for multi-day diving, if indeed they are necessary. If multi-day diving proves to be an issue, the solution is likely to be recommendations by DAN, AAUS, or others rather than dive computers based on Haldanian theory.

#### References

- Coley, R. 1991. Pers. Communication.
- Edmonds, C. 1988. "Dive Computers - The Australian Experience". *In*: Lang, M.A. and R.W. Hamilton (Eds.) Proceedings of Dive Computer Workshop, AAUS, Costa Mesa, California.
- Huggins, K. 1983. "Ultrasonic Doppler study of multilevel diving profiles," Orca Industries Publication, Toughkenamon, PA.
- Leitch, D.R. and E.E.P. Barnard. 1982. "Observations of no-stop and repetitive air and oxy-nitrogen diving," *J. Undersea Biomedical Research*, Vol. 9, No. 2.
- Lewis, J. and Shreeves, K. 1990. "The recreational divers guide to Decompression Theory, Dive Tables, and Dive Computers," PADI, Santa Ana, CA.
- Loyst, K., K. Huggins and M. Steidley. 1991. "Dive Computers," Watersport Publishing, San Diego, CA.
- Powell, M. 1987. "Recreational Dive Planning . . . The Next Generation," PADI Publication, Santa Ana, CA.
- Spencer, M. 1976. "Decompression limits for compressed air determined by ultrasonically detected blood bubbles," *J. Appl. Physiol.* 40(2): 229-235.
- Thalman, E. 1984. "Phase II testing of decompression algorithms for use in the U.S. Navy underwater decompression computer," U.S. Navy Experimental Diving Unit Report 1-84, Panama City, FL.

## Appendix A

The solution to Haldane's equations for the nitrogen loading at two different depths and bottom times can be expressed as:

$$N_1 = D_1[1 - \text{Exp}(-T_1 / t)]$$

$$N_2 = D_2[1 - \text{Exp}(-T_2 / t)]$$

where; N refers to nitrogen loading, D is the depth, T is the bottom time, and t is the halftime divided by .693 (the natural logarithm of 2). The two values of nitrogen loading will be the same provided that

$$D_1[1 - \text{Exp}(-T_1 / t)] = D_2[1 - \text{Exp}(-T_2 / t)]$$

Clearly, the exact solution is dependent on t, and we do not know *a priori* what value to assign to t. Fortunately, when we approximate the exponential by a Taylor series, the solution to first order turns out to be independent of t.

$$\text{Exp}(-T_1 / t) = 1 - (T_1 / t) + \dots$$

and substituting this approximation into the exact solution, we find the following very simple formula for estimating Equivalent Nitrogen Times (ENT) at different depths:

$$D_1 T_1 = D_2 T_2$$

or

$$\text{ENT}_2 = D_1 T_1 / D_2$$

The same reasoning leads to the conclusion that for a particular depth of a repetitive dive the RNT is proportional to the nitrogen loading. It follows that the RNT is reduced by one half for a surface interval equal to the controlling halftime, *e.g.*, for the Navy Repet Tables every 2 hours or for the PADI Recreational Dive Planner with its reduced NoD limits every one hour.

## Appendix B

The questions put forward by the AAUS in their announcement of the Repetitive Diving Workshop were submitted to all of the dive computer manufacturers or their distributors, and their reply was requested for inclusion in these proceedings. In order to simplify reading, the replies that were received were edited of equations and placed in a common format. The replies that were received came from Dacor, Oceanic, Orca, Suunto, and Tekna.

### Dacor Dive Computers Mark Walsh, Project Engineer

#### 1. *How do your devices handle repetitive, multilevel, multi-day diving?*

##### **NoD Limits and Multilevel Diving**

The Dacor MicroBrain Pro Plus calculates the diver's nitrogen absorption and elimination for 6 different tissues (compartments) with halftimes ranging from 6 to 600 minutes. For each compartment, the respective lowest surrounding pressures permitted are based on the system ZHL-12 developed by Prof. Dr. A.A. Bühlmann of Zürich, Switzerland. This pressure combined with the integrated safety margins permit diving up to altitudes of 4920 feet above sea level. Multilevel dives are calculated by the solution of the equations developed by Prof. Bühlmann every five seconds.

##### **Repetitive Diving**

Single and repetitive dive calculations take into consideration the nitrogen pressures of each tissue as represented in the model and the computer prior to the dive and corresponding with the remaining nitrogen values of the previous dive throughout desaturation and up to a 48 hour surface interval.

##### **Multi-day Diving**

Multiple day exposures are calculated the same as single, or repetitive, and multiple level profiles. The tissues with the highest level of the tolerated ambient pressure is the controlling tissue. It controls the remaining "no-decompression" time and subsequent decompression stops.

#### 2. *What feedback have you received from your user population concerning these types of dives?*

The user population have readily embraced multiple level diving with computers. Frequently participants in repetitive and multi-day diving, they also regard computer assisted diving as safer.

#### 3. *What can you tell us about future product development, particularly as it relates to depth-time recording?*

Dacor will remain a strong influence in providing equipment for the "Electronic Diver."

#### 4. *How do you "validate" your decompression models?*

The reduction of the 16 compartments of the Bühlmann System ZHL-12 to an equivalent 6 compartment model was accomplished by Prof. Dr. Bühlmann and Dr. M. Hahn in 1986, and was updated to the latest research standards by Dr. Hahn in 1987. Latest tests and evaluations of research results from pressure chamber tests by D.K.L.Z. (Zürich), B.L.F.S. (Berlin), and Navy Experimental Diving Unit (Panama City, FL) motivated Dr. Hahn in 1988 to revise the model again for safer decompression. Both manned and unmanned tests were performed during the validation employing chamber and wet exposures.

#### 5. *What do you consider to be an acceptable incidence of bends?*

To quantify an acceptable bends incidence rate assumes that the diving community as a whole has enough data to assign such a value. Dacor endorses the efforts of DAN in this regard. Based upon available information, we believe computer models that are more conservative than the U.S. Navy Air Tables reduces the level of risk of the bends for sport divers in general. This statement does not assume that all variables are known. Therefore, we decline to publish an acceptable incidence rate at this

time.

6. *Do you recommend any special training?*

Dacor requires that the user be a certified diver, fully trained in decompression theory. Advanced training is encouraged. During the past three years, we have conducted an average of 160 dive computer classes per year that have been tailored to both the instructor and consumer level. These have been two hours in duration.

**Oceanic Dive Computers**  
Brent Goetzl, Project Engineer

1. *How do your devices handle repetitive, multilevel, multi-day diving?*

**NoD Limits and Multilevel Diving**

All of the OCEANIC dive computers have no-decompression (NoD) limits that closely resemble those recommended by Dr. Merrill Spencer (15% VGE) and tested by Dr. Michael Powell of DSAT, e.g., 20 minutes at 100 feet. Further, they all provide full credit for multilevel diving. The validity of the multilevel diving control is based on the experiments of Karl Huggins and the previously mentioned experiments of Dr. Powell.

**Repetitive Diving**

The Datamaster II controls repetitive diving with a 120 minute halftime. This means that the residual nitrogen time (RNT) will be reduced by approximately one half for every 2 hours of surface interval. This design calls upon the 35 years of experience of the recreational diving community with the U.S. Navy repetitive dive tables (which are based on a 120 minute halftime) as validation of this design. When the Datamaster II was released in 1985, there was no experimental basis for a less conservative design.

The Datamaster Sport, DataMax Sport, and the DataMax Pro allow repetitive diving to be controlled by different halftimes, but at a rate that cannot exceed that of a 60 minute halftime. Typically, for repetitive depths greater than about 60 feet, the RNT will be reduced by one half every hour. For shallower depths, the surface interval required to reduce the RNT by one half will be greater than one hour. The basis of this design is the extensive Doppler monitored tests conducted in 1987 by Dr. Michael Powell of DSAT (which include multilevel repetitive NoD diving) that were designed to test 60 minute control of repetitive multilevel diving with reduced NoD limits.

For those who question the conservatism of these designs, we refer to the experiments of both the U.S. Navy (Thalman) and the Royal Navy (Leitch and Barnard) that demonstrate unrestricted Haldanian models for repetitive dive control can produce an unacceptable incidence of decompression sickness.

**Multi-day Diving**

The Datamaster II and the Datamaster Sport decompression models have a maximum halftime of 120 minutes. As a result, after a period of 12 hours, the diver is considered clean. Here again we call upon the extensive experience of the recreational diving community using the Navy tables (which also consider a diver clean after 12 hours) as the validation of this design.

The DataMax Sport and the DataMax Pro decompression models have a maximum halftime of 480 minutes. The extended halftimes were incorporated into these later designs in response to the general concerns expressed by various diving organizations about increasingly common liveaboard multi-day diving trips and the lack of understanding of any possible deleterious effects. Recent Doppler monitored experiments by Dr. Powell of 4 dives per day for 4 days in a row showed no increase in bubble count as the days progressed, but some field data imply there may be cause for concern. The 480 minute halftime incorporated in the DataMax Sport and DataMax Pro decompression models has a memory of



previous dives that can approach 48 hours.

2. *What feedback have you received from your user population concerning these types of dives?*

Whereas today multilevel diving is simply taken for granted, there is a genuine concern among users whether their dive computer predicts safe repetitive dive profiles particularly on multi-day trips. Our experience indicates a growing user sophistication, and we find that the basis of our algorithm (Rogers-Powell test data) has become an increasingly important consumer issue.

3. *What can you tell us about future product development, particularly as it relates to depth-time recording?*

The DataMax Pro was just introduced at DEMA 1991, and it is the first dive computer to provide quantitative information regarding ascent rate and the only dive computer that predicts air time remaining including a provision for consumption during ascent and decompression. We have the technology to store up to 50 dive profiles, but to date we have questioned whether the consumer is willing to bear the additional cost. If in the future we become convinced of the value of such data and consumer interest, we are prepared to promptly respond.

4. *How do you "validate" your decompression models?*

We believe that all theoretical decompression algorithms require carefully controlled and documented human testing, and we have based our algorithms on the extensive Doppler monitored NoD multilevel repetitive test data of Dr. Michael Powell of DSAT. The experiments of Dr. Merrill Spencer provide additional validation of our selection of NoD limits, and the experiments of Karl Huggins adds to our confidence of the validity of multilevel diving. Our decompression model is more conservative than either Bühlmann or the U.S. Navy, often requiring deeper stops than either of these tested tables. However, we do not believe that repetitive multilevel decompression diving has a proper experimental basis, and we strongly recommend to our users that they avoid such diving practices.

5. *What do you consider to be an acceptable incidence of bends?*

Fortunately, the occurrence of decompression sickness among recreational divers is indeed a rarity. Gilliam recorded only 7 cases among over 70,000 multilevel, repetitive, multi-day dives, and none of the bent divers were using dive computers. The majority of these accidents were "flukes" that occurred well within the tested envelope, and as such are not really preventable. In the absence of a particular diving practice that is found to repeatably produce a high incidence of DCS (e.g., one or more occurrences in 20 controlled tests), perhaps the more relevant question is "What is today's incidence among recreational divers using dive computers?", and the answer would appear to be less than 1 out of 10,000.

6. *Do you recommend any special training?*

Our design philosophy has been to make our dive computers "user friendly," and we have made every effort to make their displays simple, intuitive, and unambiguous. However, we support the idea that formal training by an experienced instructor for any specialty is always a good idea.

**Orca Dive Computers**  
Paul Heinmiller, Project Engineer

1. *How do your devices handle repetitive, multilevel, multi-day diving?*

**NoD Limits and Multilevel Diving**

All of the Orca dive computers calculate repetitive, multilevel, and multi-day diving according to the Orca decompression algorithm. The algorithm is a Haldanian twelve compartment model with halftimes ranging from 5 to 480 minutes. Compartment nitrogen limits were established in 1983 by Huggins to correspond to no-stop depth/time limits defined by Spencer to have low bubble incidence by Doppler.

### **Repetitive Diving**

We have programmed no additional limitations to repetitive diving beyond the normal results of algorithm calculations.

### **Multi-day Diving**

No specific reply. See preceding remarks.

#### *2. What feedback have you received from your user population concerning these types of dives?*

In the eight years of our use of the Orca decompression model, we estimate that 6 million dives have been logged using Orca computers. As of 1988, Heinmiller estimated 1.5 million dives, with a reported bends incidence rate of 6 per 100,000 dives. This level compared favorably with the established rate of 9 per 100,000 for use of the Navy no-decompression schedules. The detailed analysis has not been extended to the present, but the bends incidence appears to be at or below the 1988 level. In the reported bends cases, it is not unusual for one of a group of divers to have symptoms, while the others have none. This leads us to believe that factors other than the depth/time profile monitored by the computer were critical in the incident. These excellent results have been recorded in spite of extreme and unusual profiles that violate many of the recommended safe diving practices. DAN reports have noted differences between the dive profile classifications of computer based bends cases and those of table based bends cases. We feel that these differences are due to the different diving habits of the typical computer diver, and do not necessarily represent increased risk of typical computer profiles.

#### *3. What can you tell us about future product development, particularly as it relates to depth-time recording?*

Orca's Delphi Datalogger feature has established a standard for the inclusion of similar devices in future dive computers. We expect that all of Orca's future computer designs will include improved versions of this feature. The actual field data from the dataloggers will be used to develop more comprehensive decompression algorithms.

#### *4. How do you "validate" your decompression models?*

The Orca method of decompression calculation was verified by Huggins in 199 man dives designed to load each compartment to its theoretical maximum value. Testing was conducted on 12 individuals, representing the wide spectrum of recreational diving physiology, and consisted of 10 dives for each diver over a period of 4 days. Doppler evaluation of the subjects revealed one incident of Grade 1 bubbles (Spencer's grading), and no substantive DCS symptoms were noted. As the algorithm has remained largely unchanged since its release in 1983, no further manned testing has been conducted by the company.

#### *5. What do you consider to be an acceptable incidence of bends?*

We consider no level of DCS incidence to be acceptable, and have taken steps over the last three years to educate the diving public on the conservative use of any decompression calculations, whether computer or table based.

#### *6. Do you recommend any special training?*

Our publication "Dive Computers and Diving Safety," inspired by the 1988 AAUS Dive Computer Workshop, is distributed to every Orca computer owner to aid in education. We support the development of specialty course training as well as basic computer information in entry level diver training, and we hold seminars to educate instructors and dive store personnel

### **Suunto Dive Computers**

Robert Bruins, Sea Quest Customer Service Manager

1. *How do your devices handle repetitive, multilevel, multi-day diving?*

**NoD Limits and Multilevel Diving**

The Suunto SME-ML calculates theoretical nitrogen absorption and release continuously during diving and surface intervals. Because calculations are continuous, it is possible to give the diver credit for the release of nitrogen during shallower portions of the dive that occur after the maximum depth obtained. This is opposed to the Navy tables, which have no-decompression limits based on the maximum depth of the dive for the entire duration of the dive.

**Repetitive Diving**

The Suunto SME-ML uses the same 6 compartments used in the Navy tables as well as 3 additional compartments. The additional compartments expand the range the Navy tables provided. Calculations of the computer are based upon these 9 compartments for all dive times including repetitive dives as well as surface intervals.

**Multi-day Diving**

After diving the computer continues to remain activated and calculate until all compartments have returned to the same values prior to the first dive. At this time, the computer deactivates. Because the maximum time the computer can continue to track residual nitrogen is 48 hours since the last dive, multi-day dives are considered part of a repetitive series if the computer is still activated.

2. *What feedback have you received from your user population concerning these types of dives?*

No reply.

3. *What can you tell us about future product development, particularly as it relates to depth-time recording?*

Depth-time recording of the present Suunto SME-ML can be obtained in the form of a plotted graph showing maximum depths during 3 minute intervals of all dives within a given series including surface intervals.

4. *How do you "validate" your decompression models?*

Because the model or algorithm used is commonly accepted through research to obtain the Navy tables and in other dive computers, it is believed to be reliable.

5. *What do you consider to be an acceptable incidence of bends?*

Although any single bends incident is unacceptable, it is important to note that any dive computer is based solely on "mathematical" models which may not accurately describe the physiologic phenomena that occurs during a dive and therefore cannot guarantee a zero incidence of bends.

6. *Do you recommend any special training?*

Special training should be recommended for all divers that purchase computers. Each model varies in its form, display, and data given. Sea Quest recommends and provides a complete instructional program including materials.

### **Tekna Dive Computers**

Ron Coley, Director of Marketing and Sales

1. *How do your devices handle repetitive, multilevel, multi-day diving?*

**NoD Limits and Multilevel Diving**

The Computek by Tekna is a fully automatic electronic computer that has been designed to assist in multilevel decompression and no-decompression sport dives. In addition, it monitors water temperature

and estimates remaining air time. The algorithm, which is derived from the universally accepted theories of Haldane, was developed by Prof. Max Hahn of Düsseldorf, Germany. It has 8 compartments with halftimes ranging from 8 to 689 minutes, and it can accommodate depths up to 220 feet and predictions of decompression obligations of as much as 45 minutes. The Computek is one of the most conservative dive computers currently available. It treats many dives that are NoD dives on other units as dives that require a 2 to 3 minute stop at 10 feet.

### **Repetitive Diving**

See next question for comment.

### **Multi-day Diving**

See next question for comment.

#### *2. What feedback have you received from your user population concerning these types of dives?*

We have received a detailed account of a recent 4 day trip involving 13 repetitive dives that totaled 10 hours of dive time. Maximum depths ranged from 45 to 150 feet. The user dove with 3 units from various manufacturers. Most of the dives were multilevel in nature and were shown as decompression dives on the Computek *versus* NoD dives on the other units. However, at the end of a short shallow segments, all units indicated that it was safe to surface.

#### *3. What can you tell us about future product development, particularly as it relates to depth-time recording?*

I am unable to provide any information concerning future product development at this time. However, the information that can presently be recalled on the Computek is dive number, total dive time, maximum depth, and surface interval following a particular dive. Up to nine dives can be stored in memory.

#### *4. How do you "validate" your decompression models?*

Extensive computer simulation testing of the algorithm *versus* Dr. Hahn's model and equations have been performed. It would be much more appropriate for Dr. Hahn to answer any further questions concerning validation of the decompression model itself.

#### *5. What do you consider to be an acceptable incidence of bends?*

Ideally, zero. Operationally one must take into account "Freak Hits" where the diver's physiological condition might have been dramatically altered by pre-dive activities or illness.

#### *6. Do you recommend any special training?*

Advanced education is a wonderful thing that is to be both applauded and encouraged. However, the Computek design is simple to use, easy to understand, and conservative and forgiving in its decompression information. We do not assume the diver has had additional training.

## ORCA INDUSTRIES' DIVE COMPUTERS AND REPETITIVE DIVING

*Paul A. Heinmiller*  
Orca Industries, Inc.  
10 Airport Way  
Toughkenamon, PENNSYLVANIA 19374 U.S.A.

### Introduction

Orca Industries' Dive Computers; Edge, SkinnyDipper, and Delphi, calculate repetitive, multi-level, and multi-day diving according to the Orca decompression algorithm. The algorithm is a Haldanian twelve compartment model with half-times ranging from 5 to 480 minutes. Compartment nitrogen limits (M-values) were established in 1983 by Huggins (1987) to correspond to no-stop depth/time limits defined by Spencer (1976) to have low bubble incidence by Doppler. We have programmed no additional limitations to repetitive diving beyond the normal results of algorithm calculations.

### Model Validation

This method of decompression calculation was verified by Huggins (1983) in 119 man-dives designed to load each compartment to its theoretical maximum value. Testing was conducted on 12 individuals, representing the wide spectrum of recreational diving physiology, and consisted of ten dives for each diver, over a period of four days. Doppler evaluation of the subjects revealed one incident of Grade 1 bubbles (Spencer's grading), no substantive DCS symptoms were noted. As the algorithm has remained largely unchanged since its release in 1983, no further manned testing has been conducted by the company.

### Field Results

In the eight years of our use of the Orca Decompression Model, we estimate that six million dives have been logged using Orca computers. As of 1988, similar analysis by Heinmiller (1989) estimated 1.5 million dives, with a reported bends incidence rate of six per 100,000 dives. This level compared favorably with the established rate of nine per 100,000 dives for use of the U.S. Navy no-decompression schedules. The detailed analysis has not been extended to the present day, but the bends incidence appears to be at or below the 1988 level. In the reported bends cases, it is not unusual for one of a group of divers to have symptoms, while the others have none. This leads us to believe that factors other than the time/depth profile monitored by the computer were critical in the incident. These excellent results have been recorded in spite of extreme and unusual profiles which violate many of the recommended safe diving practices.

Diver's Alert Network reports (1991) have noted differences between the dive profile classifications of computer-based bends cases and those of table-based bends cases. We feel that these differences are due primarily to the different diving habits of the typical computer diver, and do not necessarily represent increased risk of typical computer profiles.

### **"Acceptable" Bends Incidence/Special Education**

We consider no level of DCS incidence to be acceptable, and have taken steps over the last three years to educate the diving public on the conservative use of any decompression calculations, whether computer or table-based. Our publication "Dive Computers and Diving Safety", inspired by the 1988 AAUS Dive Computer Workshop, is distributed to every Orca computer owner to aid in this education. We support the development of specialty course training as well as basic computer information in entry level diver training, and hold seminars to educate instructors and dive store personnel.

### **Future Development**

Orca's Delphi DataLogger feature has established a standard for the inclusion of similar devices in future dive computers. We expect that all of Orca's future computer designs will include improved versions of this feature. The actual field data from the dataloggers will be used to develop more comprehensive decompression algorithms.

### **References**

- Anonymous. 1991. "1989 Report on Diving Accidents and Fatalities", Divers Alert Network, Durham, NC.
- Heinmiller, P.A. 1989. "Orca Industries' Dive Computers". *In: M.A. Lang and R.W. Hamilton (Eds.). Proceedings of the Dive Computer Workshop, USCSG-TR-01-89, Los Angeles: University of Southern California Sea Grant Publications.*
- Huggins, K.E. 1983. "Doppler Evaluation of Multi-Level Dive Profiles". *In: R. Bridge (ed). Proceedings of the Fourteenth International Conference on Underwater Education, National Association of Underwater Instructors.*
- Huggins, K.E. 1987. "Microprocessor Applications to Multi-Level Air Decompression Problems", MICHU-SG-87-210, Ann Arbor: Michigan Sea Grant Publications.
- Spencer, M.P. 1976. "Decompression Limits for Compressed Air Determined by Ultrasonically Detected Blood Bubbles", *J. Appl. Physiol.*, 40(2): 229-235.

## SUUNTO DIVE COMPUTERS

*Bill Oliver*  
SeaQuest/Suunto  
2151-F Las Palmas Drive  
Carlsbad, CALIFORNIA 92009 U.S.A.

Both Suunto computers - the SME and the Solution - use a modified Haldanian model which agrees with Huggins' and Spencer's work in the early 1980's. The Solution differs from the SME by providing some options in pull-down menus in the memory that the SME does not. For instance, a profile menu can be opened that provides eight hours of diving history in profile form.

The block up in the right hand corner of the screen by the O in Pro is a cursor to indicate which menu is displayed. Proceeding to the next mode in the menu - the dive log function - a short version of the dive profile gives maximum depth and time for each dive in the series for approximately eight hours of diving history. The next menu option would be dive history, *e.g.* the deepest dive that the computer has made and the cumulative time that has been logged on that computer since it was put into service.

Figure 4 in the lower left corner of the screen is the mode that allows an altitude adjustment. The one significant difference between the Solution and the SME is that the user can program in altitude adjustments to make the model more conservative. It starts at one thousand feet of altitude and goes up to 8,000 feet. If the diver feels more prone to decompression risk due to behavior, condition, or severe diving conditions, this model can be made a bit more conservative by putting in the higher altitude. The last function on the right of the screen is DSI - dive simulator - allowing the operator to simulate hypothetical dive profiles.

An interesting thing about this computer, with respect to the SME, is that all of the memory function is capable of being downloaded into a PC. We have available software that services the log book and a PC interface. The dive computer locks into the modem and allows downloading of the data. It might satisfy the needs of the scientific divers who have asked to be able to get the dive data out of the computer quickly and conveniently. One can download the eight hours of diving into the PC, go dive two more hours, come back in and the computer will only recognize the most recent two hours of diving while downloading to the PC.

Another feature is the desaturation time for flying. The little airplane and the number right next to it will be the time that it takes to desaturate, which is when we say "safe to fly". The unit also has automatic startup capability, in contrast to the SME which you had to activate manually.

In the memory, besides giving the dive profile in three minute intervals, flags appear that indicate when the ascent rate for the computer (33 feet per minute) has been exceeded, or a ceiling violated, meaning that the advice of the computer to stay below the ceiling was ignored. That information is locked into the memory. The memory is an E-Prompt which means that if battery power is lost, or the batteries are pulled out, the information is stored and not lost.

When we first thought about putting a dive profiler into the computer, it was really for our purposes at the factory to see if divers were, in fact, paying attention to what the computer said; we had not intended for it to be a user option. But, shortly after introducing the SME, we found out that the dive profile or option was very interesting to the users so we have tried to enhance that feature more.

## DACOR DIVE COMPUTERS

*Mark Walsh*  
DACOR Corporation  
161 Northfield Road  
Northfield Road, ILLINOIS 60093 U.S.A.

The function of the equation is linear. It is not a fixed set point on the controlling tissue. We do travel from a controlling tissue of What we have learned in the manufacturing and the dealer instruction field is that first of all, education is the basis to use dive computers properly. Owners must read the manual to use the computer. Turn it on! It is amazing how many people do not turn on the units that do not have automatic activation. Even with automatic activation, make sure the computer turns on. Look at it! Understand it! Obey it! Then, above all, ascent rates must be slow. Come up continuously. Treat all ascents as decompression.

The calculation of the inert gas solution pressure being a linear function, we have the respective low surrounding pressure permitted, the ascent levels, the ascent times, the no-D decompression times and the desaturation times as well as time until flight, calculated for the partial pressure of N<sub>2</sub>. The solution partial pressure is at 0.643 bar and that is for the range from zero to 3,937 feet above sea level.

When we turn the Microbrain on, all of the compartments are preset, to that surrounding surface pressure. The initial pressure combined with the integrated safety margins and the coefficients of AMP, which were produced by Max Hahn, allow diving altitudes up to 4920 feet without equilibrating our tissues. Beyond that, we go to 6560 feet for additional diving in mountain lakes. Beyond that, the unit functions as a precision depth gauge, altitude, and bottom time, but without algorithm.

The "Do not fly" warning is erased when all compartments have desaturated to a partial pressure allowing the exposure at 0.58 bar - the lowest altitude aircraft cabin pressure.

Single and repetitive dives are calculated and take into consideration the nitrogen pressures of each tissue presented to the model of the computer before the dive, during the dive, corresponding with the remaining nitrogen from the previous dive, or a clean diver, the desaturation and up to 48 hours of surface interval. After a multi-day, repetitive test dive excursion one individual had 18 hours of desaturation remaining to look forward to.

As of this meeting, there are 24 dive computers on the market. The Microbrain multi-level dives are calculated by the solution of equations for all six tissues (4 minutes to 600 minutes) every five seconds during the dive. These steps result in the plotting of very accurate profiles of pressure and time exposure. We do not have downloading capability, but we do have a dive recorder built in that shows time until safe flight and desaturation time remaining for the user to use for familiarization and also to guide themselves out of the dive situation from a liveaboard with tight schedules for aircraft.

We do not want people violating the rules. I applaud those manufacturers of dive computers which have gone ahead and have a warning for the ascent rate when it has been violated. It can be called up during the log book value and it flashes. It is very important for people to be able to correct their behavior under water. If the computer shows that there is a violation and it replays that information for them, they can correct their behavior. I believe that there are incidents of deserved hits. Hopefully, by the next time we meet, deserved hits will be the next item incorporated in the log.



Multi-day exposures are calculated the same way as single dives. It takes the pressure through all the repetitive multi-level profiles. The tissue with the highest level of tolerated ambient pressure is the controlling tissue and that varies from fast to slow. It controls the no-D time and the subsequent decompression stops.

The user population has embraced dive computers and multi-level diving, obvious from an operation like Ocean Quest. There, we have anywhere from beginning divers with a deep pocketbook to experienced divers who want the latest, greatest equipment. What they have done is embraced the idea of multi-level diving, but what they have not done across the board is pay attention to what they are doing.

Recently, I had to diagnose a computer that malfunctioned. It was not the computer's fault. The computer was operating perfectly. It went into an off-mode where the unit had to be shut off and turned back on manually. That person actually went diving following that condition showing an error mode, continued following other people during the dive, came back after the dive, not knowing where they had been, not knowing how long they had been there nor what their status of decompression was. They tried to figure out what his next dive would be based on his bottom timer. He had not turned that on, either. Frequently, participants in repetitive and multi-day diving also regard computer assisted diving as safer.

Regarding future developments, we have already incorporated many of the things that we have learned in the past two AAUS workshops. Developments of this type are considered proprietary in our organization. I will be able to share them with you next time.

The validation process is through Bühlmann and Hahn. To quantify an acceptable bends incident rate assumes that the diving community, as a whole, has enough data to assign such a value. Dacor endorses the efforts of DAN in this regard. Based upon available information, we believe that the computer models that are more conservative than the U.S. Navy air tables reduce the level of risk of bends for sport divers, in general. This statement does not assume that all variables are known and therefore we decline to publish an acceptable incidence rate. We endorse certified divers to be fully trained in decompression theory. Advanced training is recognized and should be encouraged. During the past three years we have conducted no less than 160 two hour dive computer classes per year.

## TEKNA COMPUTEK

*Ron Coley*  
Tekna  
7992 Miramar Road  
San Diego, CALIFORNIA 92126 U.S.A.

Tekna, founded fifteen years ago, recently split up into three different divisions. Their military division, S-Tron, is now in Mountainview, California. The flashlight and the pocket knife division has been sold to Rayovac of Madison, Wisconsin. The scuba diving division was bought by a group of people from San Diego, California, that I have the very distinct honor and pleasure of working with. The company has moved to San Diego, where we do business as Tekna.

The Computek is the dive computer marketed by Tekna that everybody recognizes the face of with the little pictographs. "Empty the tank - Fill up the man!" In the dive equipment industry, we care about what the state-of-the-art is in decompression theory and how the equipment works. We are observant of trends, pick up the nomenclature very quickly and share this information with one another.

Typically, the diver taking a recreational trip spends perhaps five to seven days per year diving. What was learned about decompression, was probably forgotten 30 minutes after certification. For this diver, "Empty The Tank - Fill Up The Man", makes a whole lot of sense.

The Computek functions with a mathematic model, developed by Max Hahn, comprised of eight compartments ranging from 8.2 minutes to 689.2 minutes, which to my knowledge, is probably the longest compartment halftime available today. Its unique features are its graphic display and that it does present remaining air time at depth. When it comes to air, zero means zero, so when it tells you there is zero air time remaining, you have actually breathed up the hose pressure on the line.

The Computek has extremely accurate psi readings and it does appear to do a very good job of figuring out how much this amount of air will last at this depth - typically a very difficult thing for a new diver.

Computek does not fall neatly into the categories delineated by John Lewis. An example would be that a six dive series was set up to test how the computer would handle bounce dives. The goal was to make a nine minute dive to 130 feet every 80 minutes. At the end of the first dive, the Computek displays a two minute stop at ten feet. The second dive also has a two minute stop at ten feet; so does the third. However, on the fourth dive, the stop is increased to seven minutes, on the fifth dive, to 17 minutes and, on the sixth dive, to 43 minutes. In the parameters, certainly more than the half-hour for the fast compartment to completely clear has elapsed so that the unit is not totally going clean every 30 minutes. So, it does handle things differently that way.

The Computek is an extremely conservative computer at first glance. The no-D decompression limit for 40 feet is 135 minutes, compared to the 200 minutes in the Navy Tables. At 60 feet, the Computek has a 40 minute no-decompression limit, compared to 60 minutes USN; at 90 feet, only 13 minutes; at 100 feet, 9 minutes; and, at 130 feet, 5 minutes. The ascent time is not included in those no-D times. At 130 feet with an ascent rate of 30 feet per minute, there are five minutes available on the bottom and four minutes to get back to the surface. So, the times appear to be adjusted that way.

I want to point out this terrible fear of the word "decompression" or calling anything a decompression dive. I remember the AAUS workshop last year at Woods Hole, where someone sat down and in very big letters wrote the words "All dives are decompression dives!" If you stop and think about that, it is really true. When you go down, you compress and when you come up, you decompress. Whether or not that is surface decompression or staged decompression, the idea of scaring people with the thought of decompression has been ingrained in the way we teach diving in this country.

The way the Computek handles repetitive multi-level dives is probably going to shock a lot of people because most of the dive time is spent with an indicated ceiling over your head.

Diving side by side with other computers that still have two to five minutes remaining of no-D time, the Computek tells me that I have five minutes of stop time to complete. Whether or not we are going to call these stops safety stops and recommend them, or decompression stops and insist upon them, is something that a group like this should very appropriately address. With the same computers on the same dive profiles, they all let you get on the boat and let you get back in the water. On a four day repetitive series (13 dives, max. depth 155 feet, 10 hours of total submersion time), diving the most liberal and the most conservative computer on the market side by side, they were very compatible with that one exception - one asked you to take a recommended safety stop and one insisted that you took that extra time.

## REPETITIVE MULTI-DAY, MULTI-LEVEL DIVING TESTS OF THE EDGE DIVE COMPUTER ALGORITHM

*Karl E. Huggins*  
1220 Space Research Building  
Department of AOSS  
University of Michigan  
Ann Arbor, MICHIGAN 48109 U.S.A.

*During May and June in 1983 twelve subjects were exposed to a series of 10 multi-level dives over a period of four days in order to test the efficacy of the Orca decompression model programmed into the EDGE dive computer. The dives consisted of three multi-level "no-decompression" dives for three days followed by a decompression dive on the fourth day. Following each dive the subjects were monitored for venous gas emboli (VGE) formation and symptoms of decompression sickness. In the 119 person-dives completed, only one occurrence of very mild VGE formation was detected. From this study it was concluded that the decompression algorithm could be released without modification.*

### Background

In 1983 Orca Industries was preparing to release the EDGE Dive Computer. Its decompression algorithm had been designed to be more conservative than the decompression model used by the U.S. Navy in calculating their 1957 tables. The limiting surfacing supersaturation pressures (Mo values) allowed in the model's compartments were based on recommended no-decompression limits proposed by Spencer (1976) and Bassett (1982). The estimated level of VGE occurrence with these limits was 10 - 20%. These tests were conducted to ensure that the levels of VGE, produced by pushing the algorithm to its limits, fell within (or below) this range of occurrence.

### Methods

#### Determination of Test Profiles

The ten dive profiles utilized in this study were designed to simulate, and slightly expand upon, table-based multi-level diving practices performed by sport divers observed at Caribbean resorts. Each dive was intended to "push" at least one of the compartments in the model as close to its limit as possible. Since the EDGE was designed primarily as a no-decompression device, nine of the ten test profiles were no-decompression multi-level dives. The duration of each dive was limited either by decompression constraints or by the maximum dive time which could be obtained from a standard 80-cubic-foot tank with an air consumption rate of 0.5 cubic feet/min.

The nine no-decompression multi-level dive profiles were also limited by the following:

- a. Maximum depth allowed was 130 fsw.
- b. Three no-decompression multi-level dives were performed each day for three successive days.
- c. The first dive of the day was a mid-morning deep (130 fsw) dive.
- d. The second dive was a late morning shallow (25 - 60 fsw) dive.
- e. The final dive of the day was either an afternoon or night dive to a deep or moderately deep (70 - 110 fsw) depth.

- f. Each profile was to extended the algorithm as close to its limit as possible in at least one tissue group. However, at no time during the dive were the tissue pressures allowed to exceed their Mo values (remaining no-decompression time > 0 minutes).

**Table 1. EDGE Test Dive Profiles**

<u>Day I</u>	<u>Day II</u>	<u>Day III</u>	<u>Day IV</u>
<p><b>Dive #1</b>                      Start 10:00                      130' — 8 min                      To 70' - 3 min                      70' — 16 min                      To 40' - 2 min                      40' — 18 min                      To sfc - 1 min                      Stop 10:48</p>	<p><b>Dive #4</b>                      Start 10:00                      90' — 12 min                      To 130' - 1 min                      130' — 2 min                      To 50' - 2 min                      50' — 30 min                      To sfc - 2 min                      Stop 10:49</p>	<p><b>Dive #7</b>                      Start 10:00                      130' — 5 min                      To 50' - 2 min                      50' — 20 min                      To 130' - 2 min                      130' — 3 min                      To 30' - 2 min                      30' — 10 min                      To sfc - 1 min                      Stop 10:45</p>	<p><b>Dive #10</b>                      Start 16:00                      125' — 20 min                      To 30' - 2 min                      30' — 12 min                      To sfc - 1 min                      Stop 16:35</p>
<p><b>Dive #2</b>                      Start 11:33                      25' — 59 min                      To sfc - 1 min                      Stop 12:33</p>	<p><b>Dive #5</b>                      Start 11:49                      25' — 15 min                      To 60' - 5 min                      60' — 15 min                      To 25' - 5 min                      25' — 19 min                      To sfc - 1 min                      Stop 12:49</p>	<p><b>Dive #8</b>                      Start 11:36                      40' — 25 min                      To 25' - 2 min                      25' — 40 min                      To sfc - 1 min                      Stop 12:44</p>	
<p><b>Dive #3</b>                      Start 15:33                      60' — 15 min                      To 100' - 2 min                      100' — 10 min                      To 60' - 1 min                      60' — 6 min                      To 40' - 5 min                      40' — 4 min                      To sfc - 1 min                      Stop 16:13</p>	<p><b>Dive #6</b>                      Start 19:00                      60' — 10 min                      To 110' - 2 min                      110' — 5 min                      To 50' - 3 min                      50' — 20 min                      To sfc - 1 min                      Stop 19:41</p>	<p><b>Dive #9</b>                      Start 15:30                      70' — 15 min                      To 40' - 2 min                      40' — 7 min                      To sfc - 1 min                      Stop 15:55</p>	

The nine no-decompression test dive profiles are listed in Table 1 along with the decompression dive profile. Figures 1 - 4 present each day of diving graphically.

The decompression dive (dive #10) was executed on the fourth day of testing. It was designed to test the "single-stop" decompression ability of the Orca algorithm by decompressing the subjects at 30 fsw instead of performing a stepped decompression.

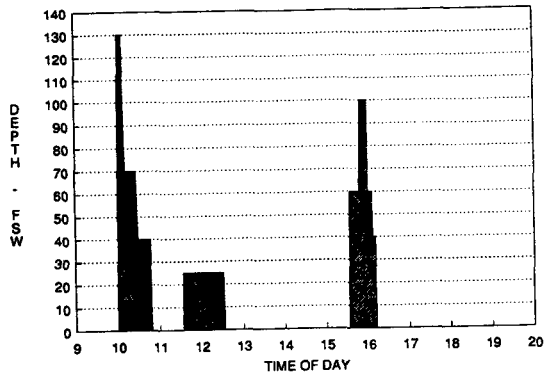

Figure 1. Day # 1, dives # 1 - # 3.

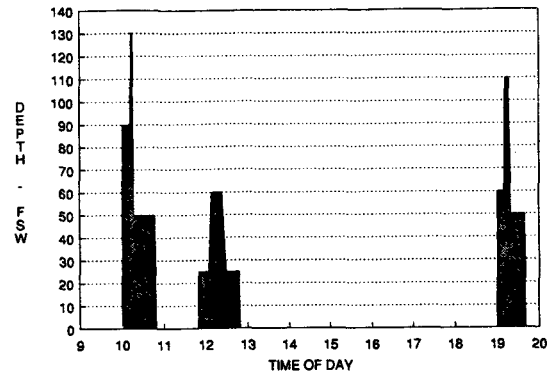

Figure 2. Day # 2, dives # 4 - # 6.

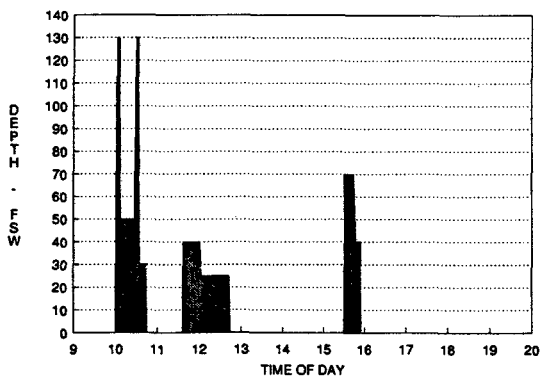

Figure 3. Day # 3, dives # 7 - # 9.

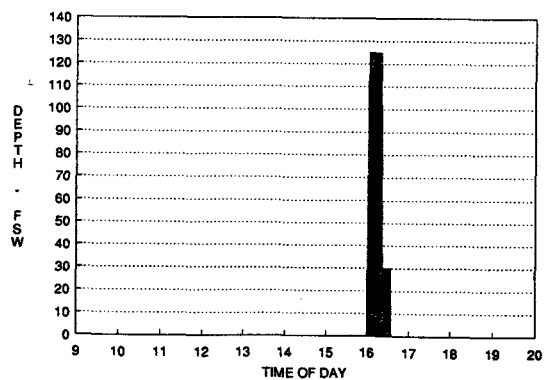

Figure 4. Day # 4, dives # 10.

**Table 2. End-of-Dive Pressures Produced by Test Dives  
(% of Mo Value)**

Half Time	Dive Number									
	1	2	3	4	5	6	7	8	9	10
5	58%	45%	62%	64%	47%	65%	58%	45%	62%	61%
11	77%	55%	82%	81%	61%	80%	78%	56%	72%	86%
17	88%	62%	91%	90%	69%	86%	87%	65%	75%	96%
24	94%	69%	95%	95%	76%	89%	92%	72%	76%	99%
37	97%	77%	96%	97%	83%	89%	94%	81%	77%	99%
61	92%	83%	92%	92%	87%	85%	89%	85%	77%	92%
87	89%	86%	92%	89%	89%	84%	86%	88%	80%	89%
125	88%	89%	94%	88%	91%	85%	86%	91%	85%	87%
197	87%	90%	96%	87%	92%	88%	86%	92%	89%	86%
271	88%	92%	98%	89%	94%	92%	88%	94%	93%	87%
392	89%	93%	99%	92%	97%	96%	92%	97%	97%	90%
480	91%	94%	100%	94%	98%	98%	94%	99%	99%	92%

The end-of-dive pressures in the model's twelve compartments are presented in Table 2. The pressures are represented as a percent of the compartment's Mo value. In all but two (#2 and #7) of the dives at least one compartment equaled or exceeded 97% of its Mo value upon surfacing. During each dive a prototype EDGE Dive Computer was carried by the subjects to check the computer's response to the profiles.

#### Selection of Subjects

Twelve subjects were selected to represent the average sport diving community. All were active scuba divers and full-time or part-time hyperbaric chamber operators, quite familiar with the risks and symptoms of decompression sickness. As shown in Table 3, the subjects represented a wide age range (21 - 62 years). Male and female subjects were selected. Body composition was not measured, but a wide range of body fat composition was present among the subjects (especially in the males).

All subjects were asked to complete a personal health evaluation prior to the experiment. Then they were briefed on all aspects of the test and given the opportunity to withdraw if they did not feel comfortable with the procedure. All subjects elected to proceed. Subject GP was not exposed to the decompression profile due to a scheduling conflict. Subject RD indicated that she had been treated for "possible" decompression sickness symptoms once.

**Table 3. Test Subjects**

Subject	Age (yrs)	Gender	Weight (lbs.)
RD	32	F	135
JE	33	M	175
HF	61	M	200
KG	28	M	180
CG	47	M	170
JJ	21	F	125
BM	25	M	170
GP	30	M	210
BR	25	M	185
DR	23	F	130
LS	46	M	190
JW	62	M	215

### **Testing Facility**

The University of Southern California's Catalina Marine Science Center hyperbaric chamber facility was used for the tests. The chamber is a 9' x 30' double-lock chamber, and is one of the major hyperbaric facilities in California for treating diving accidents. Thus, support personnel were on hand who were familiar with the symptoms and treatment of decompression sickness.

Following submission of the testing protocol, human subject approval was obtained from the University of Southern California Human Subject Board.

### **Test Schedule**

The twelve subjects were divided into three groups of four because the possibility of interruption existed. This permitted the best opportunity for at least one group to be exposed to the entire test protocol. Each group was exposed to the ten test profiles during a four-day period. The experiment took twelve days (May 25, 1983 - June 3, 1983). During this twelve-day period one emergency diving accident case was treated at the chamber. However, it did not interfere with the schedule and all thirty test dives were performed on schedule.

### **Monitoring the Subjects**

For each profile the following data was taken for each subject:

- a. Precordial Ultrasonic Doppler reading for detection of venous gas emboli (VGE).
- b. Self Evaluation on how the subject "felt" following the dive to determine any potential symptoms of decompression sickness.

The Doppler readings were obtained using a Doppler Bubble Detector Model 1032G (Institute of Applied Physiology and Medicine, Seattle, WA) with a precordial 5 Mhz ultrasonic transducer. The bubbles were graded using the Spencer 0 - IV scale. The audio signal output was recorded using a Sony TCS-310 stereo recorder.

Doppler readings were taken:

- a. 15 minutes prior to the dive.
- b. Immediately following the dive.
- c. Every 10 minutes following the dive for the first 30 minutes.
- d. Every 30 minutes until three hours surface interval had elapsed or until the next dive began (whichever came first).

The readings consisted of one minute of clear signals with the subject sitting still, followed by one minute of signals after the subjects had flexed their arms and legs (to dislodge bubbles in the extremities). Recordings were made of each of the readings to allow reevaluation on questionable signals. One variation in the Doppler reading protocol was made with the decompression dive (#10). In this case an additional Doppler reading was taken inside the chamber upon reaching 30 fsw.

Any symptoms described by the subjects in their self evaluation were recorded and coded in the following manner:

- CODE A - Vague uneasy feeling
- CODE B - Skin Itching
- CODE C - Mild Pain
- CODE D - Moderate Pain
- CODE E - Severe Pain
- CODE F - Slightly Fatigued (added during tests)
- CODE T - Slight Tingling (added during tests)



An emergency protocol was established to treat subjects who might have developed severe VGE bubble formation or signs of decompression sickness.

**Acceptable Results**

Since the Mo values were derived from limits that predict an occurrence of VGE in the 10%-20% range, it was expected that there would be little or no VGE formation in the tests.

**Table 4. Results from Test Dive Series  
(Doppler Grades & Symptoms)**

Subject	Dive Number									
	1	2	3	4	5	6	7	8	9	10
RD	0-	0-	0-	0-	OT	0-	0-	0-	0-	0-
JE	0-	0-	0-	0-	0-	0-	0-	0-	0-	0-
HF	0-	0-	0-	0-	0-	0-	0-	0-	0-	0-
KG	0-	0-	0-	0-	0-	0-	OF	0-	0-	0-
CG	0-	0-	0-	0-	0-	0-	OF	0-	0-	OB
JJ	0-	0-	0-	0-	0-	0-	0-	0-	0-	0-
BM	0-	0-	0-	0-	0-	0-	0-	0-	0-	0-
GP	0-	0-	0-	0-	0-	0-	0-	0-	0-	**
BR	0-	0-	0-	0-	0-	0-	0-	0-	0-	0-
DR	0-	0-	0-	0-	0-	0-	0-	0-	0-	0-
LS	0-	0-	0-	0-	0-	0-	0-	0-	0-	I-
JW	0-	0-	0-	0-	0-	0-	0-	0-	0-	0-

(T)-slight tingling in left leg; (F)-slightly fatigued; (B)-skin itches;  
(-)-no symptoms; (\*\*)-subject not exposed

The results would be acceptable if:

- a. No bubbles of GRADE 2 or higher were produced in any of the subjects.
- b. No pain or decompression sickness symptoms developed.
- c. The occurrence of GRADE 1 bubble formation fell below 20%.

**Results**

The results of the study are shown in Table 4. The data shows the highest bubble grade obtained from a dive followed by the symptom code. None of the no-decompression multi-level dive profiles produced any detected VGE formation or decompression sickness symptoms. The decompression profile produced Grade I bubbles in one of the subjects and skin itches in another. Two divers felt fatigued following dive #7 which included two descents to 130 fsw. The only other subjective measure was a slight tingling felt in the left leg of one subject following dive #5.

**Discussion**

The results of the study were well within the pre-determined guidelines. The results indicated that, for the profiles tested, the algorithm was safe. Based on these tests the decision was made to release the algorithm without modifications.

The almost complete lack of VGE formation indicates that decompression stress was low. Aside from the development of Grade I bubbles in subject LS and skin itches in subject CG following the decompression dive, the only other indications of potential decompression stress were fatigue and tingling.

The tingling in the left leg of subject RD was recorded because the tingling was slightly stronger, following the dive, than normal.

It is difficult to conclude whether the slight fatigue in subjects KG and CG was a result of decompression stress or other factors. The dive (#7) was performed the morning of the third day and included two relatively rapid descents to 130 fsw. This may have placed more physical stress and/or decompression stress on the subjects than did the other dive profiles. However, based on the model, dive #7 did not produce compartment pressures in excess of 94% of their Mo values.

Skin itches are not unusual following hyperbaric chamber exposures. It was unusual that there was only one reported instance of skin itches (subject CG; dive #10).

This study also documented the validity of a multi-level diving procedure. If the no-decompression dives had been performed using the U.S. Navy Standard Air Decompression Tables, an extensive decompression debt would have built up. However, no decompression steps were taken and all divers returned from the no-decompression dives free of VGE formation and symptoms of decompression sickness.

#### References

- Bassett, B. 1982. Decompression Procedures For Flying After Diving and Diving at Altitudes Above Sea Level (Validation Test), USAF School of Aerospace Medicine.
- Spencer, M.P. 1976. "Decompression Limits for Compressed Air Determined by Ultrasonically Detected Blood Bubbles," *J. Appl. Physiol.*, 40(2): 229-235.

## COMPARISON OF NO-D LIMITS FOR REPETTIVE DIVES

**Max H. Hahn**  
 Abt. f. Immunbiologie  
 Med. Einr. d. Heinrich-Heine-Universität  
 Moorenstr 5  
 D-4000 Düsseldorf 1, GERMANY

**Table 1. Comparison of No-D limits for repetitive dives.**

<b>Comparison of no-d-limits for repetitive dives</b>											
depth, bottom time	dec-stops minutes at			total ascend time in minutes	no-d-limits in minutes after 2 hours surface interval at						
36 m / 120 fsw, 15 min	9 m 30 fsw	6 m 20 fsw	3 m 10 fsw		12 m 40 fsw	15 m 50 fsw	18 m 60 fsw	21 m 70 fsw	24 m 80 fsw	27 m 90 fsw	30 m 100 fsw
<b>US-Navy (1957)</b>				2	30	25	20	15	15	10	10
<b>BSAC (1990)</b>		1		4	44	24	15	10	8	0	0
<b>COMEX (1987)</b>			3	6	0	0	0	0	0	0	0
<b>Aladin Pro (UWATEC)</b>			3	6	99	63	43	33	25	20	16
<b>DCIEM (1990)</b>			10	12	115	50	31	21	16	12	10
<b>DC11* (1990) (SCUBAPRO)</b>		1	5	9.6	98	57	39	26	19	15	11
<b>NDC (1988)</b>	1	2	5	11.6	105	60	30	20	13	10	7

\* to be comparable, without the usual setting for 1200 m (=3937 ft)

$$R = k \int \frac{P_{tiss} - P_{amb} (>0)}{P_{amb}} dt$$

$$k = \frac{\ln 2}{t_{1/2}} ; 4 \text{ min} \leq t_{1/2} \leq 240 \text{ min}$$

Figure 1. R-value computation.

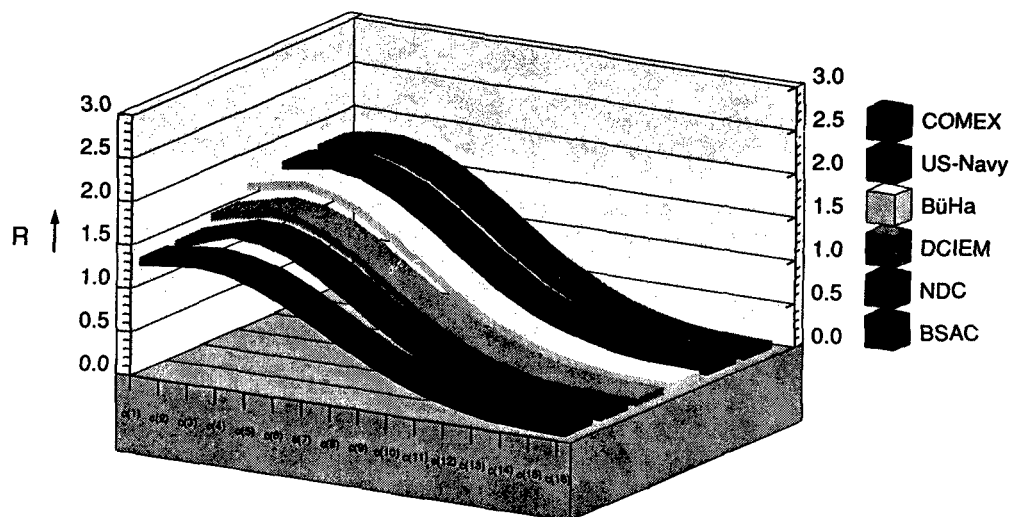

Figure 2. Maximum R-values after 24 m - 30 min / 2 hr surface interval / 24 m - 30 min.

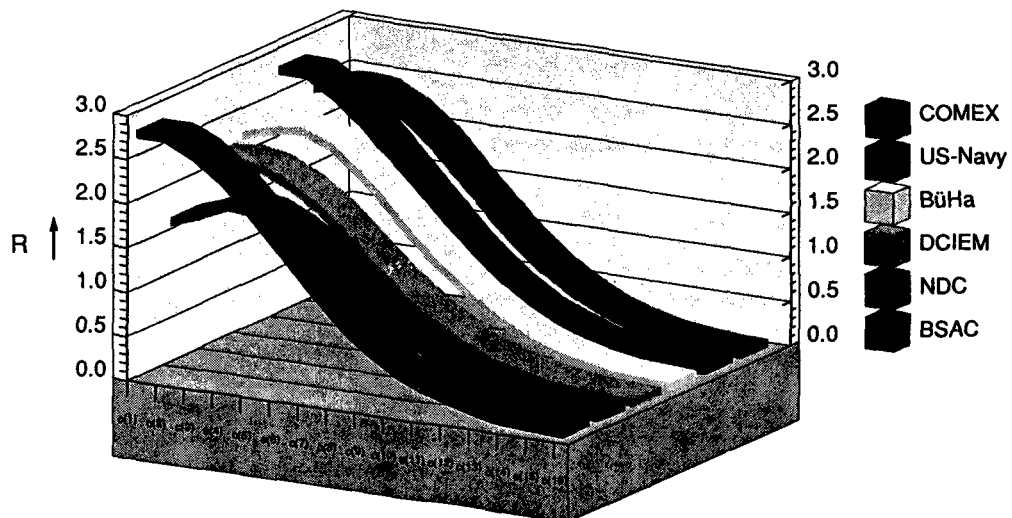
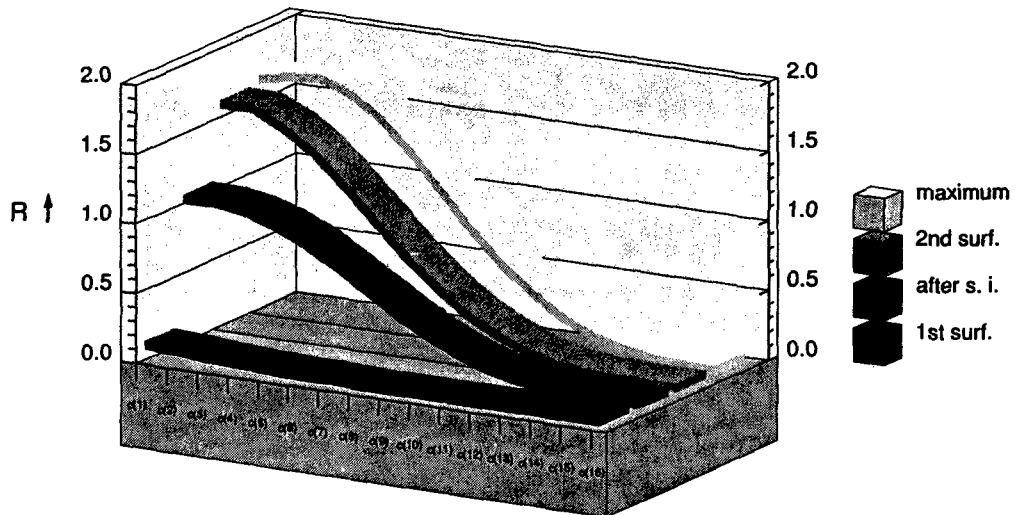

Figure 3. Maximum R-values after 48 m - 15 min / 2 hr surface interval / 48 m - 15 min.

### US-Navy table



### BSAC table

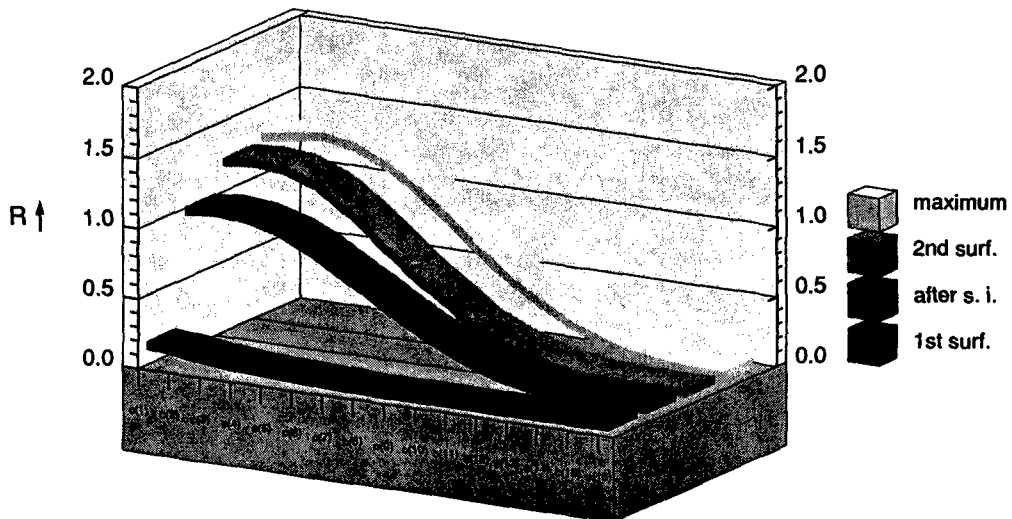

Figure 4. Graphical comparison of profiles of Figs. 3 & 4.

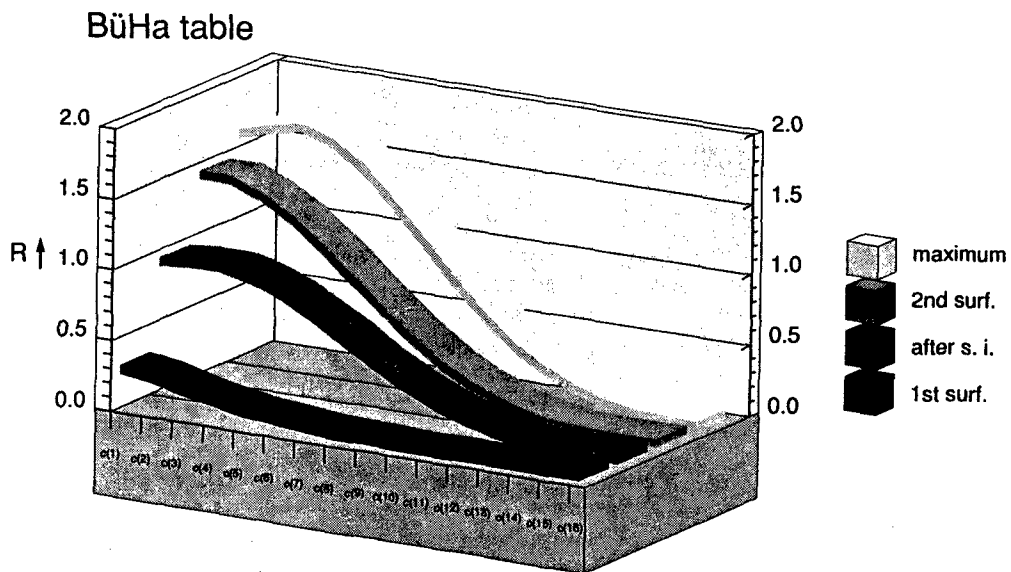
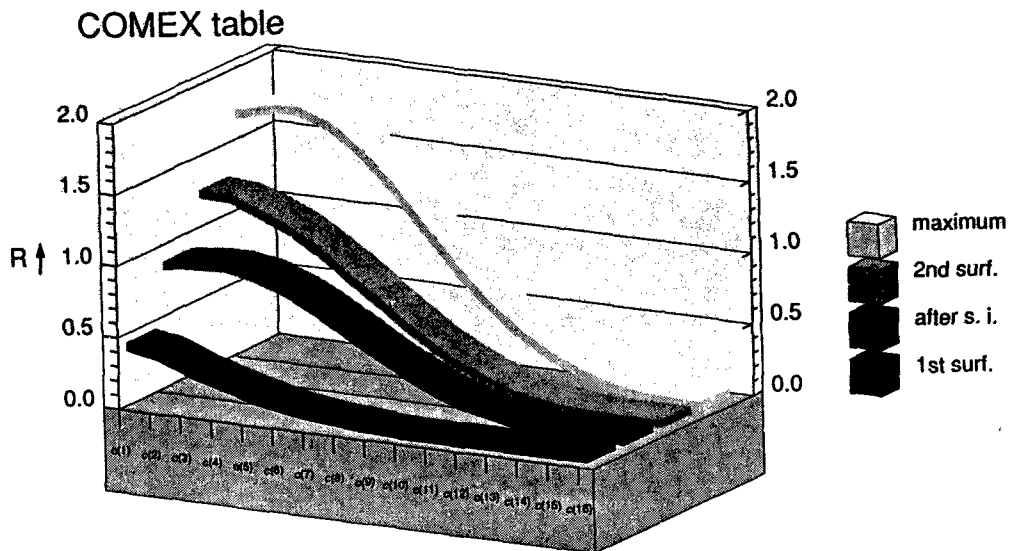

Figure 4 (cont'd). Graphical comparison of profiles of Figs. 3 & 4.

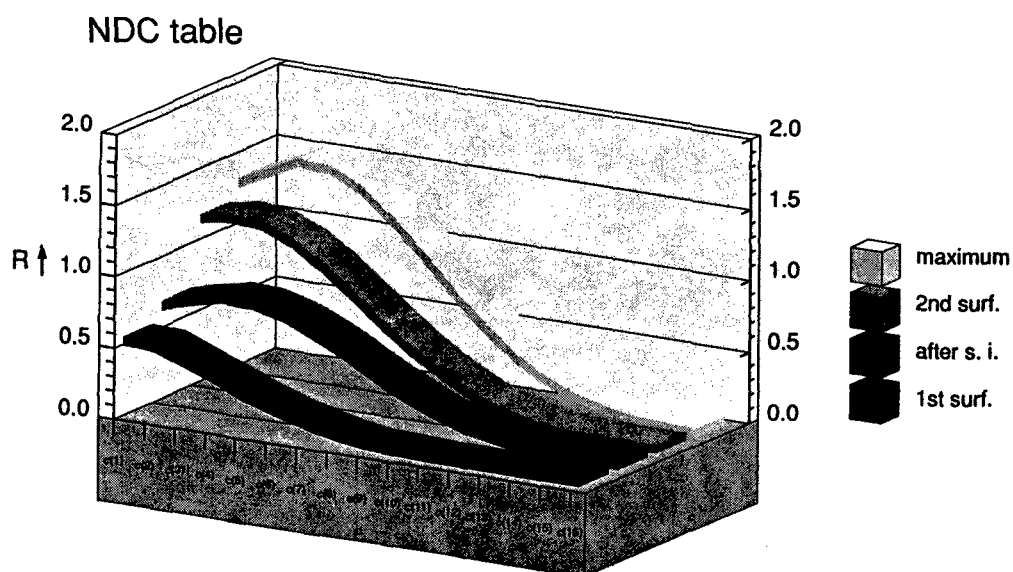
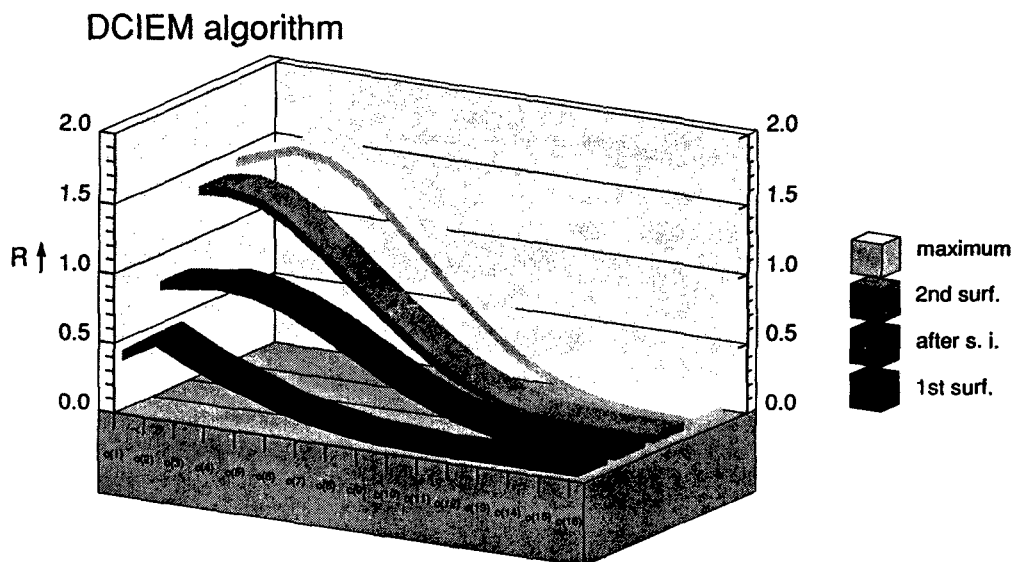

Figure 4 (cont'd). Graphical comparison of profiles of Figs. 3 & 4.

**Dive Computer Session Discussion**

John E. Lewis, Moderator

- J.P. Imbert: If the North Sea divers operating in surface decompression wear one of your computers, would you think that that would change the pattern of decompression sickness already measured? Would you think that we will find more Type I and less Type II or would it be just the same?
- P. Heinmiller: Other people may have more data to work with. We did not design our computers for the kind of exposures the North Sea divers have to undergo, so I would have no way of knowing what they would do.
- J.P. Imbert: What do you mean by different exposures?
- P. Heinmiller: The long time exposures, the extreme decompression requirements of the maximum bottom times that you are using. We tend to work on repetitive diving, surface interval repetitive dives, rather than the extreme profiles, so it is hard to compare.
- J. Lewis: Jean-Pierre, be a little more specific. Are you talking about heavy decompression diving, or are you talking about no-D diving? Give us an explicit example. Then maybe you would get a more definitive answer.
- J.P. Imbert: Consider the pressure (P, ATA) versus time (T) the dividing line defined as  $P\sqrt{T} = 25$ .
- J. Lewis: That means 25 minutes at 100 feet is 20, is that your terminology?
- J.P. Imbert: That is exactly it, yes. How would the different computers perform in this area? Could they predict any trouble with the Type II?
- P. Heinmiller: I would have no way of knowing. We have not tested our computers at the extremes that you do your diving.
- J. Lewis: Well, that is not a particular extreme. It is only 25 minutes at 100 feet.
- P. Heinmiller: We would all extend more decompression requirements then.
- J.P. Imbert: If I understand what you are saying, there is a limit in exposure in the validity of the computer?
- P. Heinmiller: Our computers would have you make deeper stops, more water time for decompression and what the results of decompression sickness are, would have to be tested to find out. We are all operating under the concept that more decompression is better. How you do it might be very important.
- J.P. Imbert: Would computers be of any help in preventing Type II decompression sickness? Can they make any predictions about whether you are going to get Type I or Type II?
- P. Heinmiller: No.
- K. Huggins: If you are looking at a single square profile which is what they are doing in commercial diving primarily, and if they are pretty much using the U.S.Navy Table, all the current computers have models that are more conservative than that. So, for a single square wave profile, they will always be giving more conservative decompression.
- J. Lewis: With the exception of the Suunto USN and the Seiko Scuba Master.
- K. Huggins: Right, except for the modifications that they may be making to their procedures. If we just look at what the Navy Tables would say, theirs would be more conservative than that, or if you are using the Navy Table based computer you would get the same as the Navy.
- J. Lewis: I am not sure about the North Sea. I do not remember those numbers, they are talking 20 minutes at 100 feet, if I read that right. That is by far the largest group with the dive computers that you have here. With the exception of the repetitive dive control, you are going to find that they behave similarly although more conservative with respect to decompression and I do not think anybody wants you to take them deep into decompression and will not let you.
- J. Chimiak: The Navy is currently testing its air algorithm that is going to be brought down to the Experimental Diving Unit this summer. It is currently in its first phase at NMRI and one of the features is a surface decompression option. Which dive computers would be able to handle a diver in a dry environment if you brought him up and then went into a chamber? I know some of them right now cannot be put into the chamber unless they are in a wet container.



- J. Lewis: There are a fair number of them that want to be wet.
- B. Oliver: The new Solution computer is potted with a silicone gel. If you put it in the dry environment and dive it, it will get bent itself if you bring it up too fast because the gel will absorb  $N_2$  at depth. It does need to be at least in a jar of water.
- M. Walsh: That is also true about the Microbrain, potted in silicone gel, that gas diffuses into the gel and be careful coming back up, especially on a bounce dive.
- R. Coley: The Computek can dive dry because it is not a potted computer.
- P. Heinmiller: All ORCA computers can be dived dry, although the Delphi with the air pressure sensor would not be as interesting in a chamber as the SkinnyDipper or the Edge. But, there is no danger with any of the computers. We do pot the Skinny Dipper but it is not silicone gel.
- J. Lewis: The Oceanic and the Data Masters can be put in a chamber, but the Datamax Sport does not like that. It has a problem with the transducer.
- R. Eckenhoff: I was looking for some fairly straightforward outcomes, we ought to have some data on that. Specifically, incidence, comparison of the table versus the computer divers as far as the population goes. Data is what I am looking for. Do they, in fact, improve outcome or not?
- P. Bennett: We know which computers are giving the highest data and so on, but we will not release the data for various legal reasons. We will give data to any company that wants information on their diving accidents. What they do with that, is their right to do. On the data, we do not feel that that is a situation we particularly wish to get into. We have discussed it at great length with our attorneys and they feel this is not a good line to cross. Versus tables, we know that the number of diving accidents with computers is increasing steadily. It is increasing, no doubt, because there are more on the market. We would like very much to know exactly how many, which might give us a better baseline. This has been the problem all along. What we were thinking of trying to do was to get an island like Cayman or Jamaica and get all the dives on that island. Then we will know which ones are computers, which ones are tables, have a baseline, know how many accidents and we will get a real handle on what is going on.
- H. Vidars: As far as the data that DAN has as to which accidents are caused by which computers, do you differentiate within that data as to which of those accidents are definitely caused by diver error as opposed to malfunction of the computer?
- P. Bennett: You are asking a great deal. There is an attempt to differentiate as much as we can, but I do not think our forms, as such, at the present time, differentiate that finely.
- J. Dovenbarger: Very rarely is it a computer-caused error. Generally, it is a diver-caused error when the computer is involved. There is really no outstanding feature about computer dives that makes them substantially different from table dives.
- C. Wachholz: DAN is trying to get funding for an analysis of the computer cases in great detail because, often it is the operator error and there are many other factors involved in an accident. It is not just because they are diving with a computer and that requires very careful review of individual cases.
- M. Powell: I gleaned from the multi-day repetitive Doppler studies that we did with the PADI tables that the results are profile dependent. You get less bubbles with square than with deep staged dives. There is no firm proof that that is true. My impression was surface interval dependent, even though all the divers were within the limits of the model which had been shown to work at least for one or two days. When we had four dives per day, it was all right. When we had six dives per day, we had problems even though they were all beneath the table limits. My question then concerns the five dives per day for five days. How many individuals made this? Is this a test or what?
- M. Walsh: This was a test of equipment. Two of our individuals were out and that was the reading on the unit at the end of the week. It was not a test of the dive computer. It was other equipment being tested.
- M. Powell: In other words, these were not necessarily to the limits of the table every single dive?

M. Walsh: No, it was not.

J. Chimiak: I notice the tissue half-times have just progressively gotten longer and I think you have made a note of that. What happens when the dive computer fails? What are the diver's options? Does the diver completely stay out of the water based on the residual nitrogen time that he may have incurred? If you are taking into account 689 minutes, can you make the assumption that he is going to be clean in 12 hours, or do you have to use the half-time tissues?

J. Lewis: Let me answer it in an indirect way. I once got all charged up about this because the biggest sales gimmick in town was how many compartments and how long the half-times were, so I designed a computer. It had one thousand compartments. They went from six seconds up to 24 hours. The next morning it had ten minutes of residual at 40 feet and the rest was clean. It is not clean in these lower compartments, but somebody needs to sit down and prove what that all means in any kind of realistic situation.

P. Heinmiller: As a direct answer, we addressed this question at the 1988 AAUS Workshop, at which point we stated in the recommendations that you must be clear for 18 hours before you turn on a dive computer. Those of you who were not there need to know that was a compromise answer. The original answer from Tom Neuman was 24 hours. The compromise of 18 hours was arrived at to deal with people diving from a research vessel at a cost of \$10,000 per day and it was said that we could compromise, because these were smart people and they would be more conservative when they go back in the water after 18 hours.

J. Chimiak: With dive computer failure, as far as getting back onto table format, if during your surface interval it gave a designation, say A, B, C designation, this would give a dive planning type of situation where a diver could go to a table format like you are discussing here.

J. Lewis: All you need to do is look at its pre-dive scroll and ask what its RNT was at 60 feet when you first got on the surface and then just put yourself into group D or whatever that corresponds to and go about your business.

B. Oliver: Exactly.

P. Heinmiller: Only if the letter group produced by that computer had anything to do with any letter group produced by any table manufacturer, which none of them really do.

P. Sharkey: If you go back to the 1988 AAUS Dive Computer workshop, Mike Emmerman has a paper in there that he derived. It is a fair amount of work, but you know right where you are and if the computer fails, you can always get yourself back on it, but it can also easily be used during surface intervals in order to give yourself a repetitive dive group and put yourself back on the Navy tables. It is similar to what John just suggested. However, taking the single number for 60 feet does not always turn out to be the most conservative cell to choose. So, we did it for every one that it scrolled at us and sometimes we found that 60 was a good one and sometimes we found that there are other ones that were somewhat more limiting, so we always took the one that was more limiting.

J. Lewis: I really did not mean it to be all-encompassing, it was just a conceptual idea. But, you surely should do it with a relatively shallow depth because I know for sure you are going to get in trouble with the deep depths using the double-E's.

M. Emmerman: We did that with five foot depths in C once in a while. That procedure worked consistently if we took the readings, the level bottom times at 30 feet, 40 feet, 50 feet, all the way down to 90 feet. We then went back to figure out what the group letter would have been with RNT and took the most conservative one, using that for going back into the table.

J. Lewis: That would be toward the shallower depths, I guess.

M. Emmerman: Yes, but we did label that procedure experimental, I might add.

J. Lewis: In fact, there are two table-based units, the Suunto USN and the Seiko Scuba Master, that obviously can get back onto the table directly.

C. Wachholz: Yes, I had one question. I think it is a fair statement that a lot of the accidents that can be attributed to computers are operator error. On the other hand, I think it is also a given that divers, unless they are led by the nose, are not going to do a lot of study on decompression theory, or

- perhaps read the entire manual. This is the way things are. The question that I commonly get at DAN in regards to the safety of computers or how can we make them safer is what can be done to minimize the number of repetitive deep dives that are able to be done with a lot of these devices?
- B. Oliver: We are addressing it with education. The Solution computer comes with a videotape user's manual because we know that people do not read manuals, so we give them a 20 minute videotape that talks about how to use the computer intelligently and comments on some safe diving practices with profiles. Additionally, to make the unit diver proof, we went to the automatic startup because with the SME the comments that we got on the computer not working properly were operator error. People would fail to activate the computer before they went in the water.
- M. Walsh: We do not have an override. We are an international company and over in Europe they like deep and they like repetitive diving, including decompression diving, so from a marketing standpoint, we cannot override the domestic unit and the European unit. What we can do is educate and we try to do that to the best of our ability.
- R. Coley: I guess the thing to say is that the Computek is so conservative at this point in time that there is a very limited history out there. To my knowledge, there have been no hits, but I would certainly like to take Dr. Bennett up on finding out if there is anything. As a manufacturer, I know that you do not always find out about the accidents your equipment's involved in. The fact that there is almost a three month waiting line to use a computer that is this conservative tends to show me that there is a market for a device that takes the approach that more conservative is safer and safer is better, but I cannot prove that.
- P. Heinmiller: If we keep moving towards more and more conservative, we might as well all stay out of the water right now, which is the direction that these things seem to be heading. Our model has been out three years and it is not perfect. None of them are. We need to educate the people.
- M. Hahn: As I see it, the answer is another kind of model that prevents yo-yo diving, without restricting normal profiles too much.

**JOTRON DIVE RECORDER**  
and

**CONSIDERATION OF SOME GENERAL ASPECTS OF DIVE RECORDER OUTPUT**

*Russell E. Peterson*  
Peterson Technical Service  
1104 St. Anne's  
West Chester, PENNSYLVANIA 19382 U.S.A.

The value of accurate and complete dive profiles to decompression research and development was recognized many years ago (Peterson 1976). The relatively recent development of analytical tools such as maximum likelihood (Weathersby *et al.* 1984) have made the availability of such information even more important. Until recently, however, it has not been possible to obtain suitable data from open water dives, and even the retrospective processing of profiles from onshore research and test dives has proved difficult, impractical, or impossible because of missing detail (Peterson, 1976).

Advances in computer technology, particularly miniaturization of components, have made it possible to develop instruments which can accurately and reliably obtain open water dive profiles, even in commercial offshore settings. Thus, the opportunity exists to obtain a large number of profiles conducted with a variety of operational techniques and divers. To make the most effective and efficient use of such information, however, requires:

- That all critical data elements be associated with the time-depth profiles;
- That the data be easily interpretable; and,
- That the data be accessible for responsible use.

Some ideas on how the preparation of useful dive profiles might be facilitated are presented below. Details of an accurate and durable dive recorder system developed in Norway are presented first, however.

#### **Jotron Dive Recorders**

Two types of computer-based dive recorders are currently manufactured by the Norwegian firm, Jotron Electronics A.S. These are an on-line system and an off-line system. On-line dive recorders are hard-wired to a PC compatible computer on the surface, permit real time viewing of dive depths and use of that information in dive conduct and, can superimpose a selected decompression schedule on the computer monitor to facilitate the precise following of that schedule. Commercial-type dive logging and time-stamped comments features are also included in the supporting software. With this system, pressure is sampled every 2.5 seconds and stored with time whenever a change of 0.01 bar is detected. Up to four sensors can be monitored by one system. This would be suitable for a typical commercial diving operation with two divers, a closed diving bell, and a deck decompression chamber. An extensive validation trial was conducted with this system in a commercial setting in the British sector of the North Sea, and the units are now being installed on commercial diving vessels, particularly in Norway.

The Jotron off-line dive recorder is comparable to a commercial aircraft "black box." It periodically checks pressure to see if that parameter has changed by more than some critical amount. If so, the time, pressure, and other selected parameters are stored in the unit's memory. After a dive, the profile data

is downloaded into a PC-compatible computer through a serial port interface. Both the sampling interval and the critical pressure change of the off-line dive recorder are under user control. Sampling rates of one per second to one per minute can be specified during the pre-dive initialization process and pressure changes from 0.001 bar to 0.250 bar from the last stored value can be set to cause data storage. Other parameters which can be obtained with the Jotron off-line dive recorder are the internal temperature of the unit, representative of ambient temperature after an interval of equilibration, an external temperature, the PO<sub>2</sub> of a gas (*e.g.*, breathing bag of closed-circuit UBA). The off-line dive recorder uses rechargeable batteries which have a capacity of about 150 hours. When the charge on the batteries becomes low, the dive recorder stops sampling in order to retain sufficient power to preserve the data already in memory. The standard off-line system has sufficient memory to record 5,386 values for each of three parameters. The dive duration this would cover is, of course, dependent on sampling frequency, critical depth change factor, and the nature of the time-depth profile of the dive. With a sampling frequency of once each 5 seconds and a depth change factor of 0.5 msw, the standard memory would comfortably record a typical 8-hour dive. Units with the extended monitoring capabilities (*i.e.*, external temperature and PO<sub>2</sub> sensors) have a memory capacity which is twice that of the standard unit.

A commercial diving trial has also been conducted in England with the Jotron off-line dive recorder system. This occurred over a six-month period in 1987. One interesting result of this trial was that, during the period the dive recorder was in use, no cases of decompression sickness occurred at the dive site. This was in contrast to a small, but definite incidence of decompression sickness which occurred both before and after the dive recorder trial. It has been concluded that use of the dive recorder caused those involved in the dives to be more attentive to operational detail. Off-line Jotron systems are now being used in England, the United States, Denmark and Norway. Systems have also been ordered by organizations in the Netherlands and Singapore.

Both the on-line and off-line dive recorder systems store data in binary files, but can output it in spreadsheet-compatible ASCII files. Other common details of the systems include graphics features with cursors to obtain precise evaluation of time-pressure pairs from a dive profile, the ability to output the graph of a dive to a plotter and, date and time stamps taken from the computer used for off-line system initialization or on-line system processing. Transducers are available for pressure ranges of 0-10 bar, 0-30 bar, and 0-60 bar. The accuracy of the systems is conservatively estimated to be 0.10%-0.20% of full scale.

### Output of Dive Recorders

If several different types of dive recorders were used by a diver during a single dive, it is likely that the output of each recorder (*i.e.*, the time-pressure pairs) would be different, even though each were describing the same dive. This is because the recorders would almost certainly not function in precisely the same manner. As a result, it is necessary to know exactly how a specific dive recorder functions and what sampling/storage criteria have been used in order to properly interpret its output. In addition, information other than the time-depth profile is critical to the utilization of dive records for most purposes. This additional information includes the time-gas profile, diver identity (actual or coded), and dive outcome with respect to decompression sickness. Further, unless details of the diver's exposure history before the dive are available, some information related to the repetitive dive status of the diver must be included to ensure proper assessment of the data.

To facilitate utilization of the output of dive recorders and to ensure that critical information is not lost/dissociated from their records, it would seem important to establish some formal means for reporting dive details. Such a formal description, or "transcript," should be independent of dive recorder function and would be derived from the output a dive recorder by means of an appropriate software transfer function. The transcript, for completeness, should also require inclusion of the other details which are necessary for routine use of the dive record in decompression research and

development. Another valuable feature would be the ability to include related, non-critical (*i.e.*, secondary) information about the dive in the transcript.

Several notational systems exist which might serve as a basis for the routine transcription of dive recorder output. One of these is the format of CANDID, the Canadian Defence and Civil Institute of Environmental Medicine's dive data base. Another is PENNDEC (Pennsylvania Decompression System). This latter system was developed at the Institute for Environmental Medicine, University of Pennsylvania, in the early 1970s by the Institute's computer programmer/analyst, Hillel Bardin. It was part of the effort to establish an International Decompression Data Bank of validated research dive profiles. PENNDEC, in particular, has many attributes which would make it appropriate for the transcription of dive recorder output and the development of a general-use dive records system. These include providing a comprehensive and complete record of a dive, use of different transcription modes for the convenient description of both simple and complex dives, a well-defined syntax, transcripts which can be easily understood by humans, an interface format for the compact storage and computer processing of dive records, the easy incorporation of secondary data, and good documentation. An introduction to PENNDEC as a possible transcription format for dive recorder output has been published previously (Peterson, 1989). The best description of PENNDEC is the comprehensive documentation prepared by Bardin (1973).

If the concept of a standardized notational system for the output of dive recorders receives support, then several factors, in addition to those mentioned above, should be considered. These include:

- If the objective of a standardization effort is only to establish a means to conveniently exchange and utilize complete profiles taken by dive recorders, then a relatively simple system will suffice.
- If a more comprehensive dive records data exchange system is the objective, however, then for such a system to be functional and lasting, it must be able to accommodate records from all types and modes of operations, not just single-mix bounce dives. Thus, any transcription scheme which is adopted should facilitate the recording of all dives including those which are relatively complex (*e.g.*, multi-person, multi-chamber saturation-excursion dives).
- Though no currently available system is likely to be entirely satisfactory in its existing form, and this includes PENNDEC, the modifications required to produce a good system from an existing one should be relatively minor. The development of an entirely new system, on the other hand, could entail considerable time and expense and would not necessarily produce an improvement on that which is already available.

### Conclusions and Recommendations

At this formative stage in the development of dive recording systems, the matter of dive recorder output should be carefully considered. Mechanisms to ensure the inclusion of all data necessary to utilize dive profiles for documentation and analytical purposes would be of critical importance to the establishment of a successful, comprehensive dive data bank. In addition, the standardization of dive transcript formats would greatly facilitate the use of dive records for all concerned. Failure to establish and agree specifications for dive recorder output would, on the other hand, risk the loss of much valuable data and make utilization of dive profile records more difficult. Thus, PENNDEC, the CANDID format, and any other system with potential for the transcription of dive recorder output should be examined, and some course of action, related to the standardization of dive profile transcripts, should be adopted by dive recorder manufacturers and the users of dive records. Such a plan would be relatively easy to implement at this time because relatively little time and effort have been put into sophisticated data input/output techniques. The general implementation of a standard format

would not be as easy to achieve in the future, however, when multiple approaches had already been adopted.

#### References

- Bardin, H. 1973. PENNDEC: A computer oriented language for recording decompression experiments. Institute for Environmental Medicine Rep, September 1973.
- Peterson, R.E. 1976. International decompression data bank. *In*: Harvey C.A., Parker J.W. (eds.) Diving Data Banks. Report No. WS: 2-15-76. Bethesda: Undersea Medical Society, Inc. p. 4-11.
- Peterson, R.E. 1989. Standardization of format for dive recorder transcripts. *Marine Tech Soc J.* 23(4): 61-65.
- Weathersby, P.K., Barnard, E.E.P., Homer, I.D., and Flynn, E.T. 1984. On the likelihood of decompression sickness. *J. Appl. Physiol. Respir. Environ. Exercise Physiol.* 57(3): 815-824.

## SAITAMA DIVE RECORDERS AND ANALYSIS SYSTEM

*Yoshiyuki Gotoh*  
Department of Hygiene  
Saitama Medical School  
38 Morohongo, Moroyama, Iruma-gun  
Saitama 350-04, JAPAN

The accurate knowledge of dive profiles is necessary if the causes of diving accidents are to be understood and if decompression sickness is to be prevented and properly treated. Dive profile data should be recorded without interfering with normal diving activity. In 1976, with these goals in mind, we developed our first dive profile recorder and a system for analyzing dive profiles.

### Development History of the Saitama Dive Recorders

Our original models used amplitude modulation (AM) and frequent modulation (FM) tape recorders to record depth signals (Fig.1a). Unfortunately, the motor drive mechanisms of the recorders introduced noise and drift which degraded the quality of the stored data.

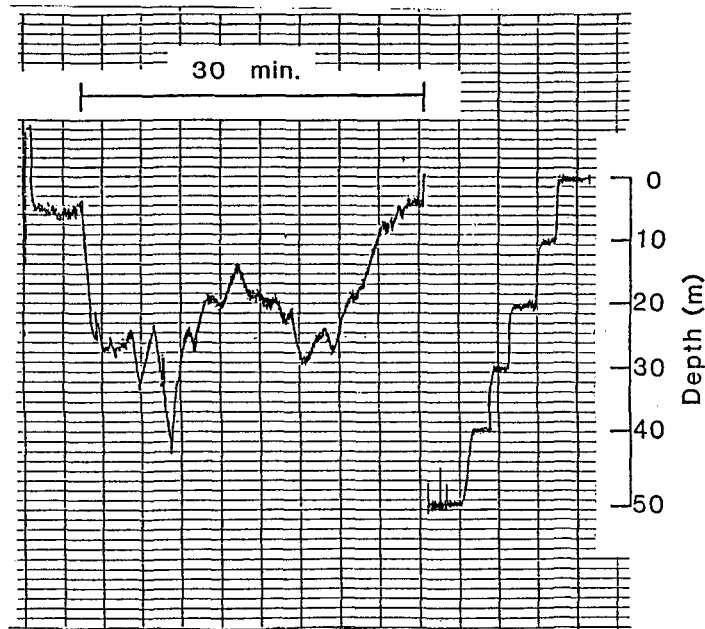

Figure 1a. Dive profile using FM tape-recorder;



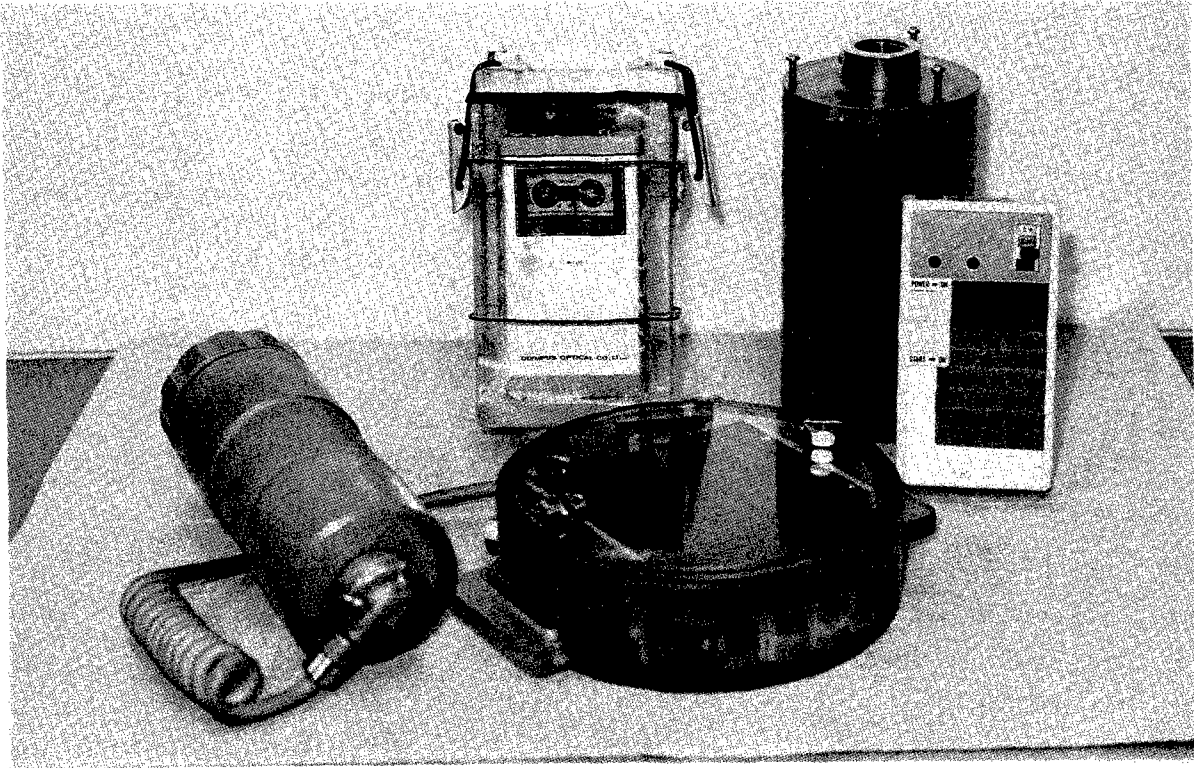

Figure 1b. DMR 1 - 2.

To eliminate noise and drift, we changed the memory system from a tape recorder to integrated circuits (IC), and in 1982, developed the first models of the IC Diving Memory Recorder, the DMR-1 and DMR-2 (Fig. 1a). These models used a strain-gauge pressure sensor, preamplifier, analog-to-digital converter, timer, counter, and 2 K-byte IC memory unit. Depth was sampled at intervals of 3 to 30 seconds and stored sequentially. Dive profile data were recovered using a counter, trigger circuit, digital-to-analog (D/A) converter, and pen recorder. The next year, we developed a personal computer (PC) interface.

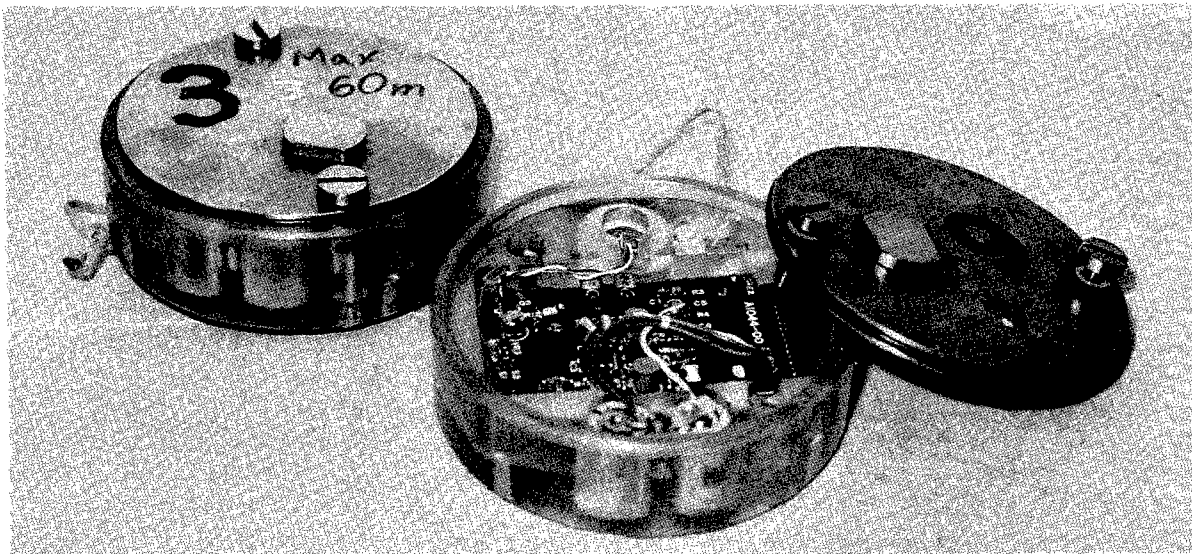

Figure 2. DMR - 3.

The same 2 K-bytes IC memory was used in the DMR-3 (Fig. 2), but depth was stored at 30 second intervals to save memory. The DMR-3 proved to be handy and solid and could record 17 hours of diving data. We have obtained the data of 195 daily dives using the recorder in commercial and sport diving.

In 1983, we introduced the DMR-4 which used a detachable 12 K-byte IC memory card and had a sampling rate that was selectable at 1, 3, 12, or 30 seconds. The DMR-4 (Fig. 3) proved too large for practical use, however.

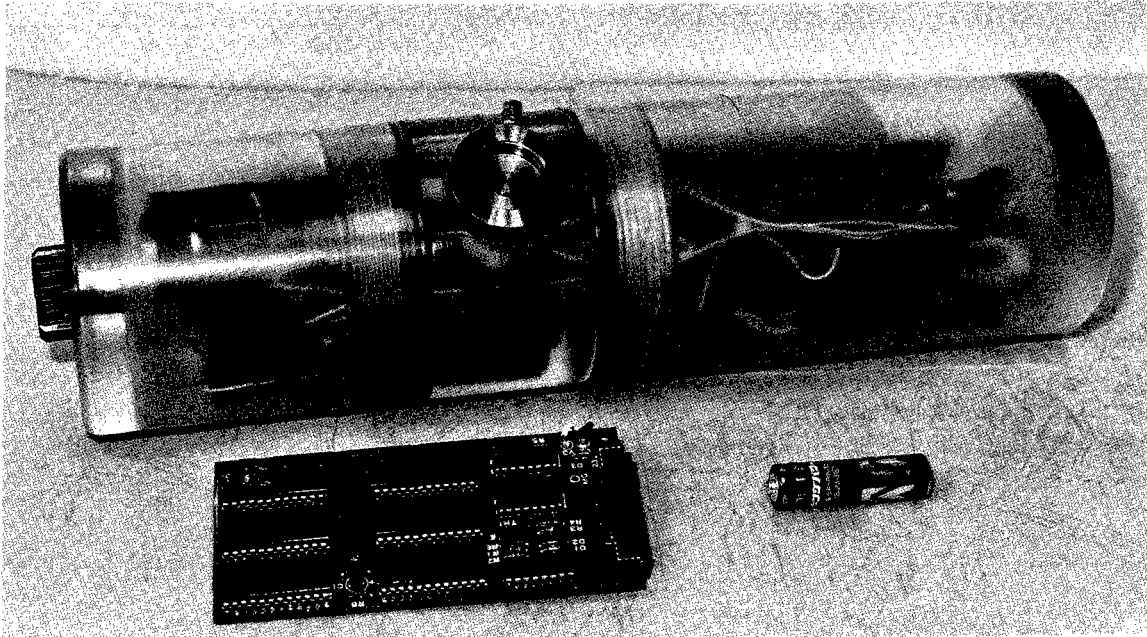

Figure 3. DMR - 4.

The DMR-5 (Fig. 4) was the first model to use a microprocessor, a Z-80 CPU with a clock. A Phillips pressure sensor also was introduced to improve depth accuracy and, under CPU control, was only turned on intermittently to save power. Previously, depth but not time were stored sequentially, and this wasted memory.

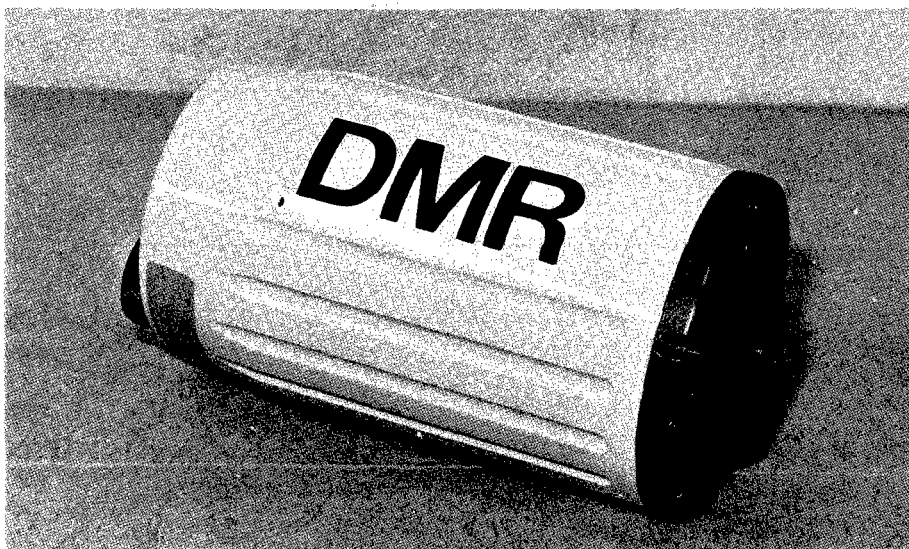

Figure 4. DMR - 5.



Data were transferred from the DMR-5 to a personal computer through a RS-232C interface. As RS-232C is an international standard, it is possible to transmit diving data by phone anywhere in the world. This facilitates the storage and analysis of data. Figure 5 shows dive profiles which were transmitted over an international telephone cable using acoustic couplers from a hotel in Australia to our laboratory in Saitama, Japan. Figure 6 is an example of the data format used for telecommunication. To allow efficient data compression, special command characters are included. Data were transmitted in blocks of 250 bytes. The transfer rate was about 10 seconds per one hour of dive time.

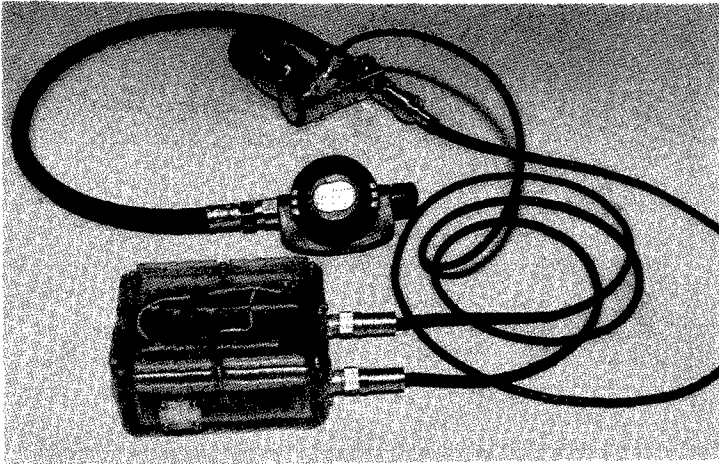

Figure 7a. DMR - 6.

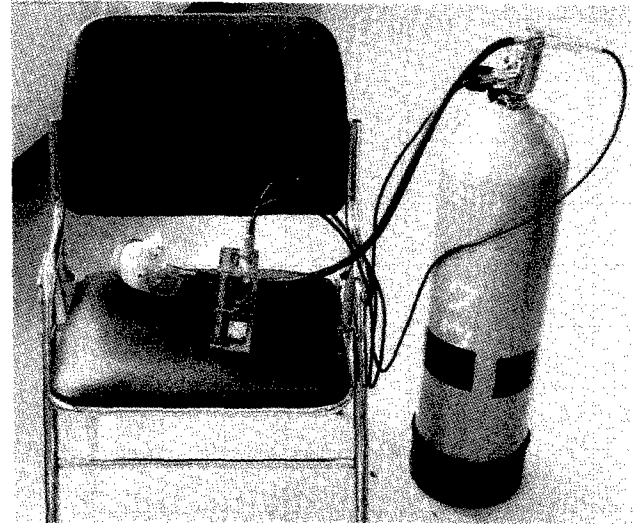

Figure 7b. DMR-6 attached to SCUBA tank

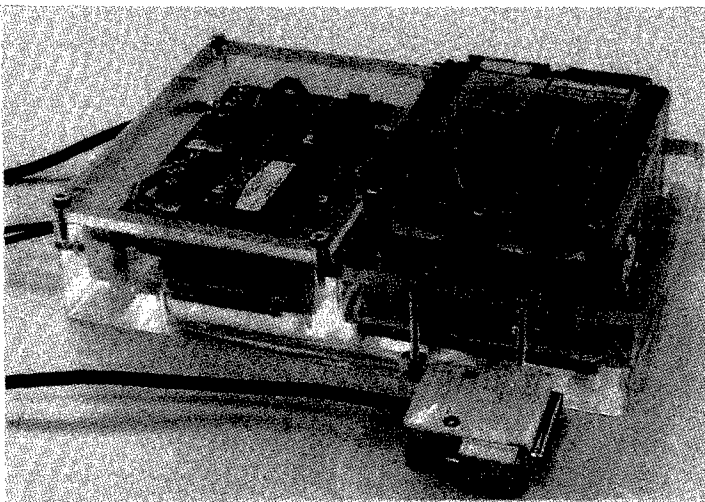

Figure 7c. DMR - 6.

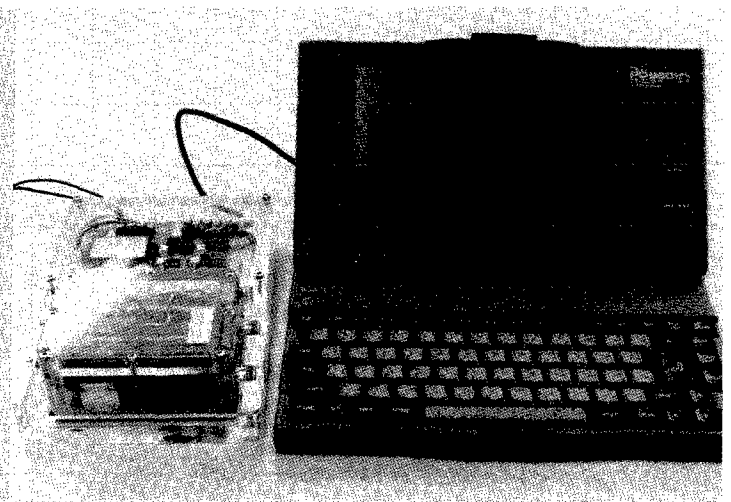

Figure 7d. DMR-6 connected to PC

Our latest unit is the DMR-6 (Fig. 7) which is multi-channel system that incorporates a one Megabyte memory chip to record time, depth, water temperature, tank pressure, and the breathing frequency. Depth is sampled every second and averaged at three second intervals by the 6303 CPU.

The water temperature is sampled at three second intervals while the tank pressure and breathing frequency are sampled at six second intervals. Arithmetic averages are determined for these variables at 30 second intervals. Averages are stored sequentially in rotating memory such that new data overwrite old data when the memory capacity is exceeded. Data transfer to a personal computer occurs via an optical interface. Figure 8 shows the only dive profile recorded by the DMR-6 to date. It was a 32 minute recreational dive which required 4.4 K-bytes of memory for storage.

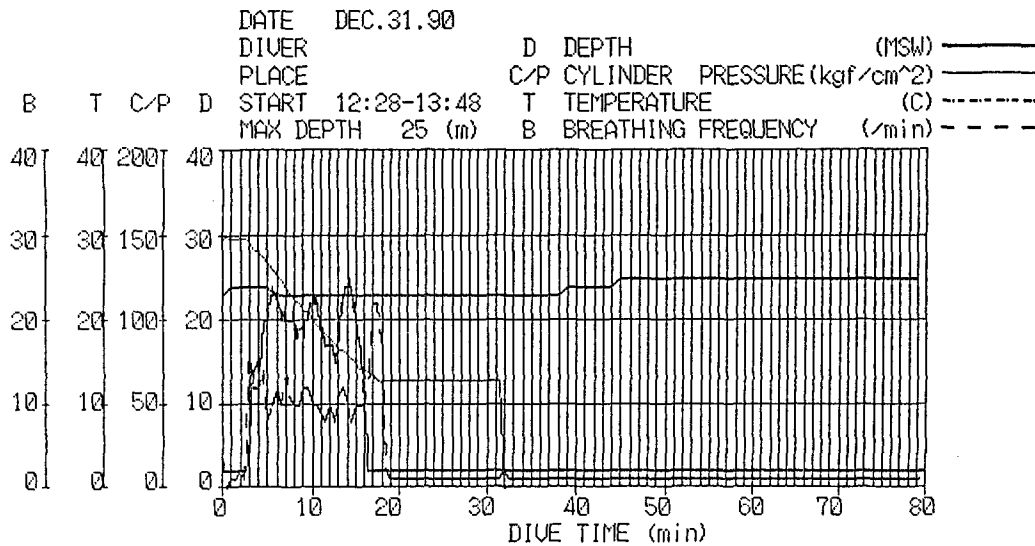

Figure 8. Dive profile using DMR - 6.

### Repetitive Dive Profiles

We have studied the diving habits and post-dive precordial bubbles of harbor divers, abalone divers, and recreational divers (Gotoh, 1987; Gotoh *et al.*, 1987; Kobayashi, 1987). Venous gas emboli were monitored on the dive boats using a portable Doppler bubble detector (Institute of Applied Physiology and Medicine, Model 1032G).

Figure 9 shows the square, repetitive dive profiles typical of harbor helmet divers who were leveling a stone rubble bed for a breakwater foundation. We recorded 20 daily dive profiles for nine divers and their precordial Doppler bubble scores after surfacing. The dive depths were 16 to 18 meters with bottom times of 55 to 104 minutes. Three to five no-stop dives were made each day. Doppler bubbles of grade 1 to 3 were detected in 12 of 20 repetitive dives.

Figure 10 shows multi-level dive profiles for six abalone divers using compressed air with surface-supplied helmets. The dive depths were 16 to 36 meters with bottom times of 16 to 38 minutes and total ascent times of 19 to 29 minutes. The bottom depth fluctuated as the divers searched for shellfish. The first decompression stop was usually taken at 5 to 10 meters, and the divers moved up and down during decompression over a range of 2 to 6 meters. Decompression profiles were empirical with no adjustments for repetitive dives. The third dive was the shallowest, performed at 10 to 19 meters with no decompression stops. Doppler bubble scores of grade 2 were detected in three of the six divers after their second dives, but no decompression sickness was reported.

The DMR-3 was used to record 134 daily dive profiles made by sport divers. Precordial Doppler bubble detections were performed in 50 repetitive dives and 12 single dives. Doppler bubbles were

detected in 32 repetitive dives. Another 42 sport dive profiles were recorded using the DMR-5 without bubble detection. In the profile shown in Fig. 11, the diver suffered a mild bend. Doppler bubble scores of grade 3 were detected 5 hours after his surfacing.

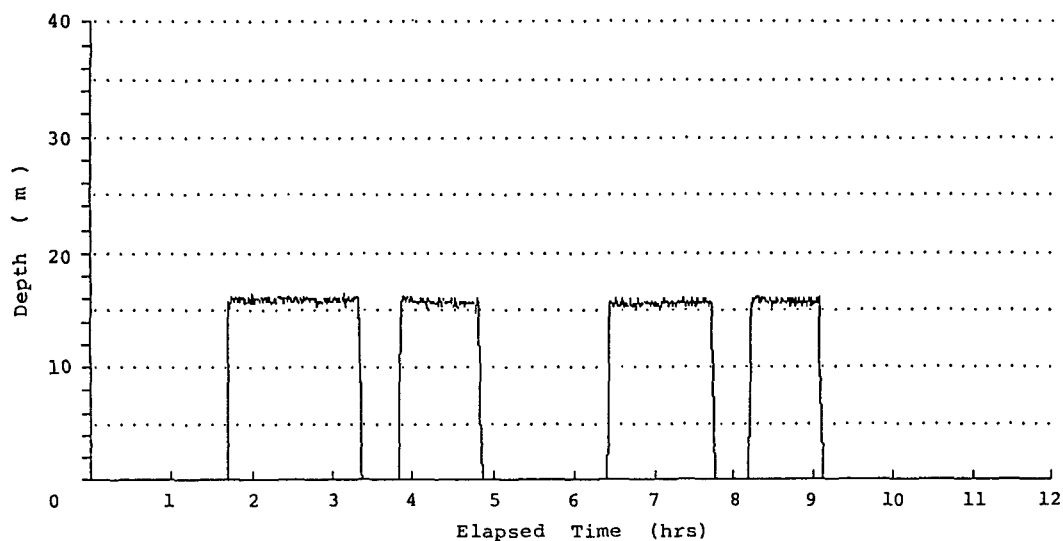

Figure 9. Dive profiles of a harbor diver.

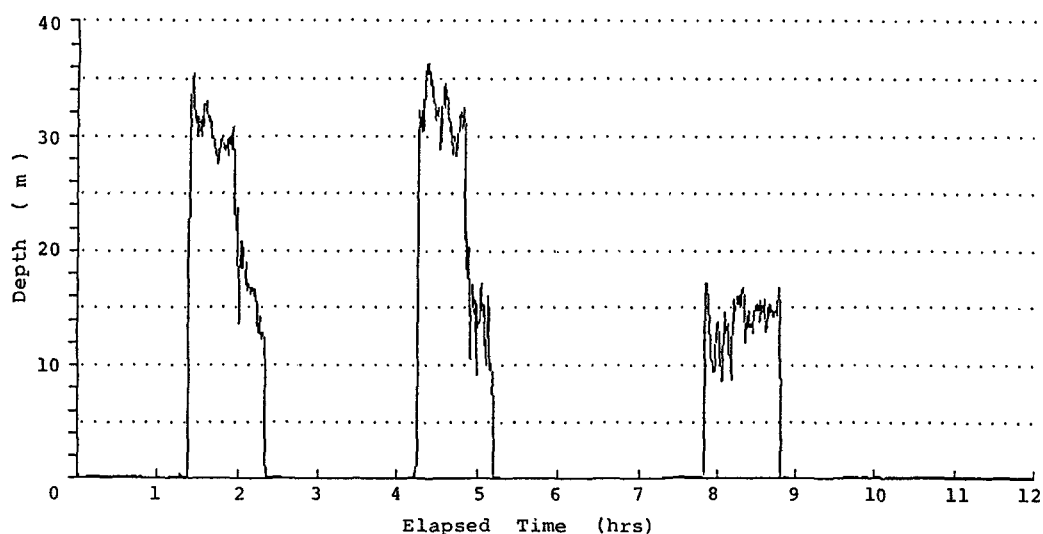

Figure 10. Dive profiles of an abalone diver.

#### Data Compression for Optimal Storage in Recorder Memory

To examine the degree of deterioration caused by data compression procedures, we compared the data taken by compression type recorder (DMR-5) with those by non-compression type (DMR-4). A recreation diver carried both recorders and data were taken simultaneously. Figure 12 represents the dive profiles reproduced from the data. There is little difference between the two dive profiles. The compression and non-compression type recorders required 337 and 1271 bytes of memory to store the data, respectively. It is clear from these results, that appropriate data compression will be useful to reduce memory requirement with no considerable deterioration of accuracy.

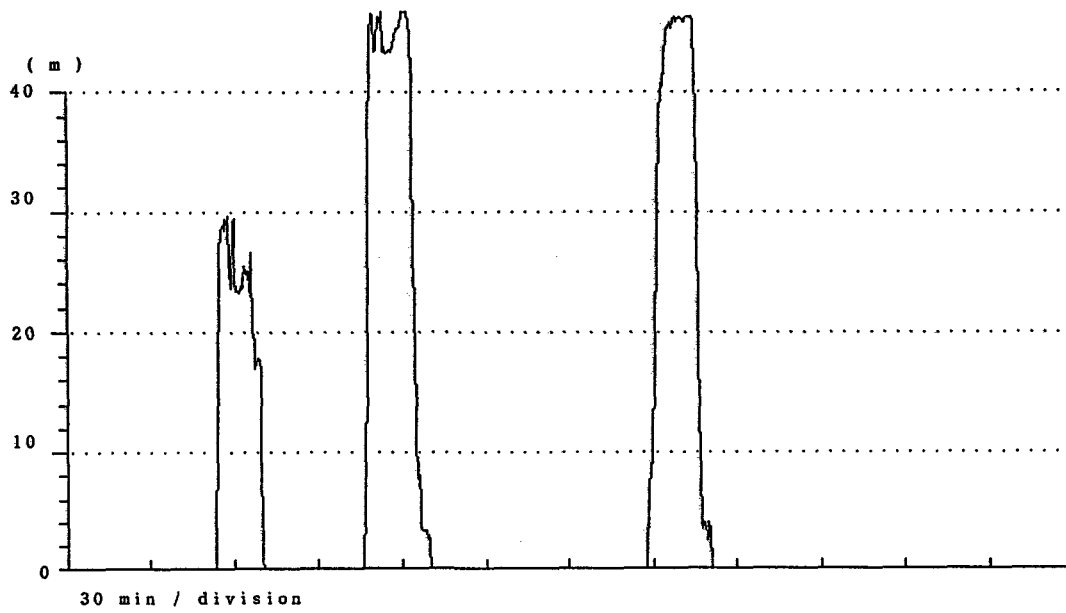

Figure 11. Dive profiles of a sport diver who suffered from mild bends.

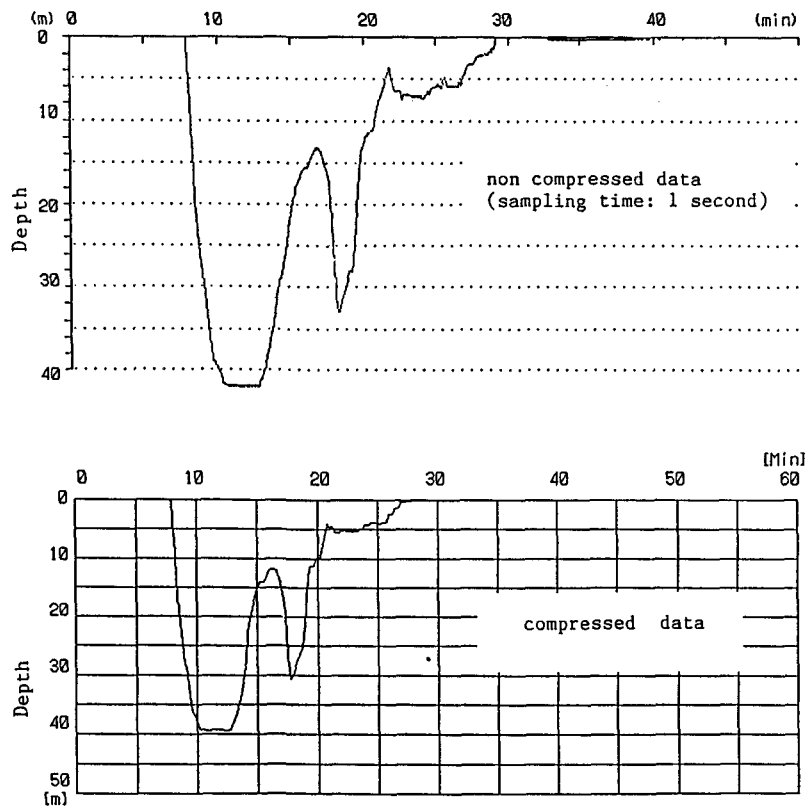

Figure 12. Comparison between compressed and non-compressed data.

### Reduction in Memory Requirements by an Increased Sampling Interval

A further reduction in memory requirements is possible by sampling data at 3 instead of 1 second intervals. To confirm whether or not 3-second sampling period is practical, we took data of breath-hold dives in which descent and ascent were done rapidly. Figure 13 shows the dive profiles reproduced from the data. There is no significant degradation of the dive profile. Diving data can be obtained by 3-second sampling with sufficient resolution.

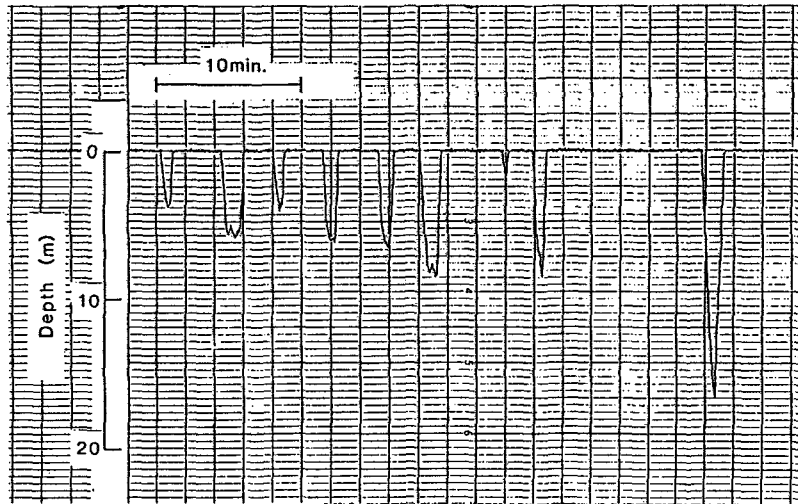

Figure 13. Breath-hold diving profiles with IC memory system. Depth signals were picked up every 3 seconds.

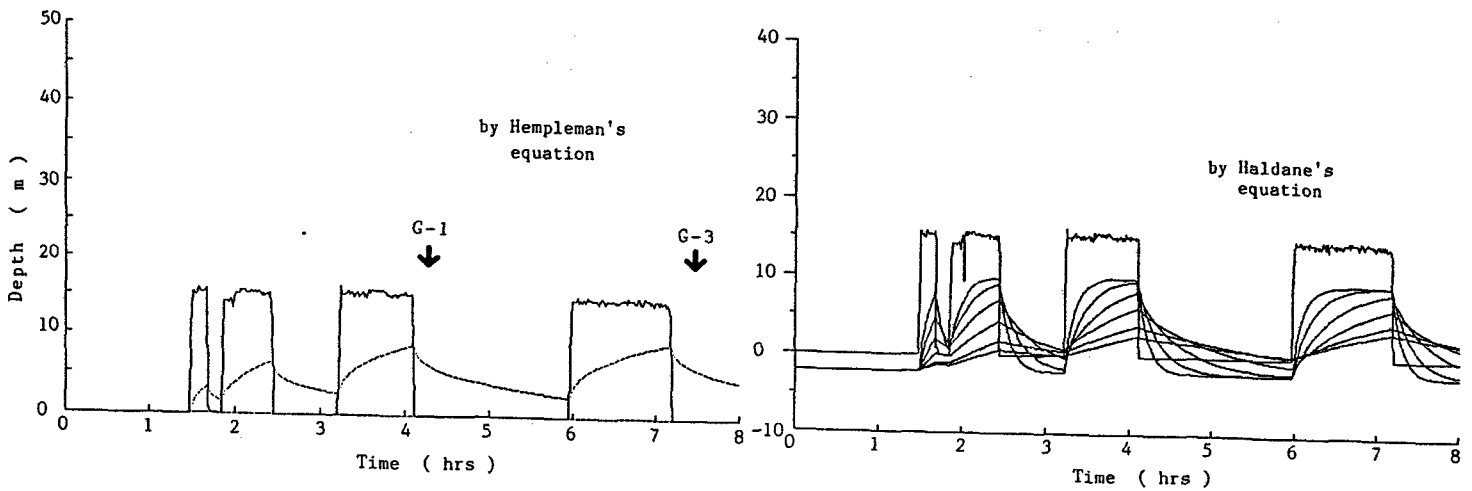

Figure 14. Changes in tissue nitrogen partial pressure.



### Analysis of Dive Profile Data

Decompression tables are usually based upon the Haldane decompression theory and its modifications. An alternative method uses Hempleman's modifications to Haldane's exponential equations. We analyzed the recorded dive profiles using both these procedures. Figure 14 shows the Haldane and Hempleman nitrogen tensions for the same dive profile.

While still incomplete, this analysis suggests several conclusions pertaining to Doppler bubbles detected after the 12 repetitive harbor dive profiles. Decompression stops were required by theoretical calculation for 6 dives but were omitted by the divers. Calculation indicates that the tissue nitrogen tensions were nearly the same after both the early and late dives. This would seem to contradict the observation that there were more Doppler bubbles after the late dives than after the early dives and suggests that nitrogen elimination is slower than nitrogen uptake. Theoretical models which attempt to simulate the appearance of Doppler bubbles might be more successful if they incorporated nitrogen elimination which was slower than nitrogen uptake.

### Acknowledgement

The author wishes to express his thanks to Dr. R.D. Vann for careful review of this manuscript.

### References

- Gotoh, Y., K. Kobayashi, R. Araki, F. Eda and I. Nashimoto. 1987. Diving Profile Recording System and Its Application. *In: Proceedings of the 9th meeting of the United States-Japan Cooperative Program in Natural Resources (UJNR) panel on Diving Physiology and Technology.* pp. 99-110
- Gotoh, Y. 1987. Unusual dive profiles. *In: Nashimoto I, and E.H. Lanphier (Eds.) Decompression in surface-based diving.* Undersea and Hyperbaric Medical Society Inc. Bethesda. pp. 25-28.
- Kobayashi, K., M. Nodera, Y. Gotoh and I. Nashimoto. 1987. Dive profiles in sport divers. *J. Jap. Hyp. Med. Soc.* 22: 163-170.

## UNDERWATER PHYSIOLOGICAL DATA LOGGER

*John Henderson  
Richard Morin  
Albert Olszowka  
Bruce Laraway  
Suk Ki Hong*

Department of Physiology  
Center for Research in Special Environments  
State University of New York at Buffalo  
Buffalo, NEW YORK 14214 U.S.A.

*An Underwater Physiological Data Logger was developed, which is small enough to be readily used (without interfering with diving activities) in the field by divers to completely document the diving depth-time profile, the heart rate, the body temperature, the temperature of water (in which the diver is engaged in diving work), frequency of respiration, and velocity of swimming through the entire day. Such a device has been used in four different groups of divers: Korean Female Cachido (unassisted), Japanese Male Cachido, Japanese Male Funado (assisted), and Surface-based Compressed Air Divers of Taiwan. All Korean and Japanese divers are breath-hold divers. In these field tests, the measurements of depth, skin and sea water temperature and the heart rate were successful; on the other hand, the measurements of the frequency of breathing and swimming velocity were not satisfactory and require additional R/D work.*

### Introduction

Along with the arrival of microminiature integrated circuit technology, came the possibility to develop a computer assisted "dive logger" which can accurately and continuously record a number of dive parameters of all dives performed by a diver through an entire day, under natural conditions, and without interfering with diving work. Such a logger was used, in August, September 1989-90, to study the daily dive pattern of Korean and Japanese breath-hold divers and Taiwanese surface-supplied scuba divers who are engaged in underwater forage all year round. The earliest study on Korean Ama was done nearly 30 years ago when data was collected by hand. Eight dives were recorded as opposed to over 1200 recorded in a six day period in the present study by the computer assisted dive logger to determine diving velocities.

### Technical Description

Six items of data are stored into Logger Data Memory. They are: Depth, Sea Water Temperature, Skin Surface Temperature, Heart Rate, Respiration Rate, and Swimming Speed.

The Data Logger is housed in a water tight Plexiglass cylinder, 9 inches long and 4.5 inches in diameter, and is worn on the subject's back. (Fig. 1).

All electronics are implemented on three stacking 3 x 5 inch circuit cards. The heart of the system is an Onset Computer Corp. Tattletale Model 2 Single-card Data Logger (Fig.2). It has a 6303

microprocessor, and Tattletale BASIC in firmware. It has 256K bytes total dynamic Ram, 224K bytes of which reserved for data memory, eight channel 8-bit analog to digital converter, 14 digital I/O lines used for data collection and control of external logic, and 9600 baud serial port for communications with a host computer. The entire system draws approximately 30 milliamp from the 9-volt battery.

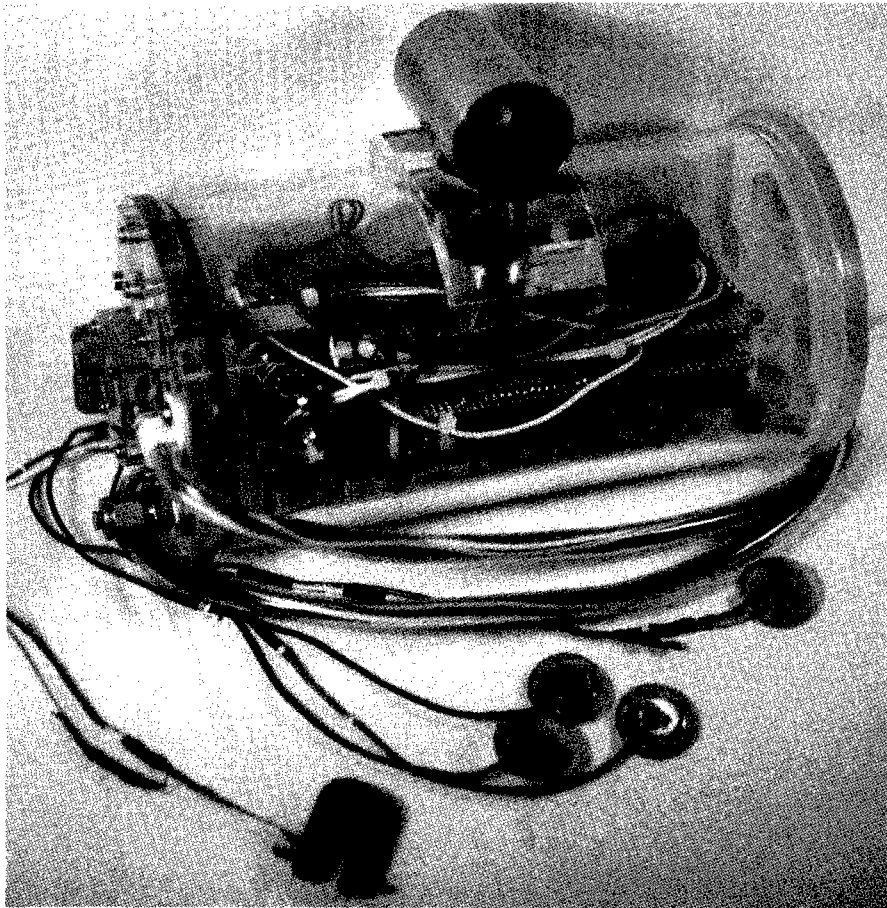

**Figure 1. Underwater physiological data logger developed at SUNY Buffalo.**

A program has been written in Tattletale BASIC which controls timing, sequencing, and storing of data. In the morning, this logging program, which runs the logger during diving, is downloaded from the host computer through the serial port and is stored in the program storage area of the logger memory. Similarly at the end of the working day the data accumulated by the data logger is uploaded to the host computer which stores it on a floppy disc.

The Depth is measured by a piezoresistive pressure transducer, made by Omega (Model PX90-300SV), in a Wheatstone Bridge circuit configuration (Fig. 3). This signal is then conditioned on board for proper gain and offset, then connected to one of the eight analog to digital converter inputs for storage into the 8-bit Data Memory.

The two Temperature channels use thermistors, YSI 44006, and are electrically identical. The Sea Water thermistor is mounted in a fitting protruding from the container. The Skin Temperature thermistor is mounted at the end of the subject cable in a skin surface mounting much like an ECG

electrode. Each thermistor is connected through an on-board passive resistance network to the appropriate A-D converter input (Fig. 3).

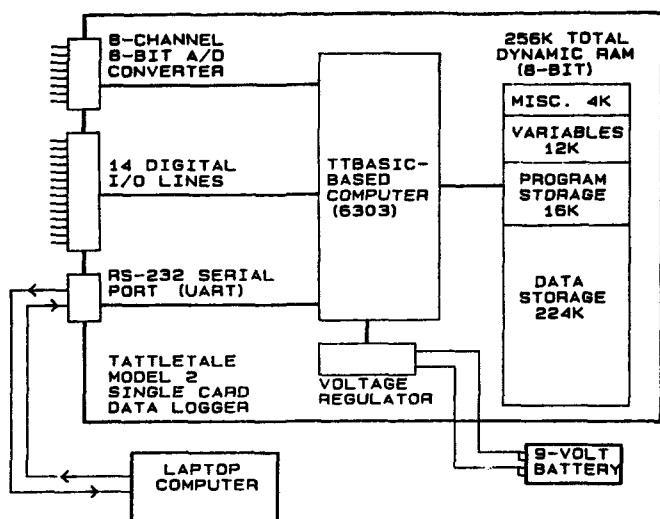

Fig. 2. Block Diagram - Tattletale Circuit Board.

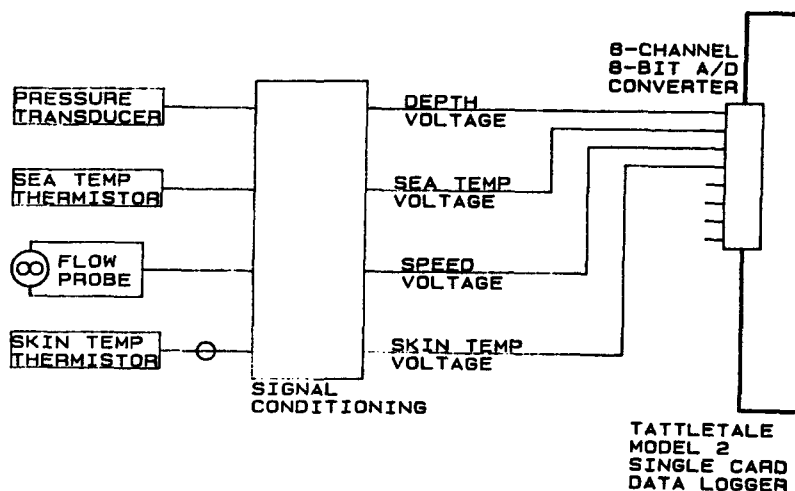

Fig. 3. Block Diagram - Analog Circuit Board.

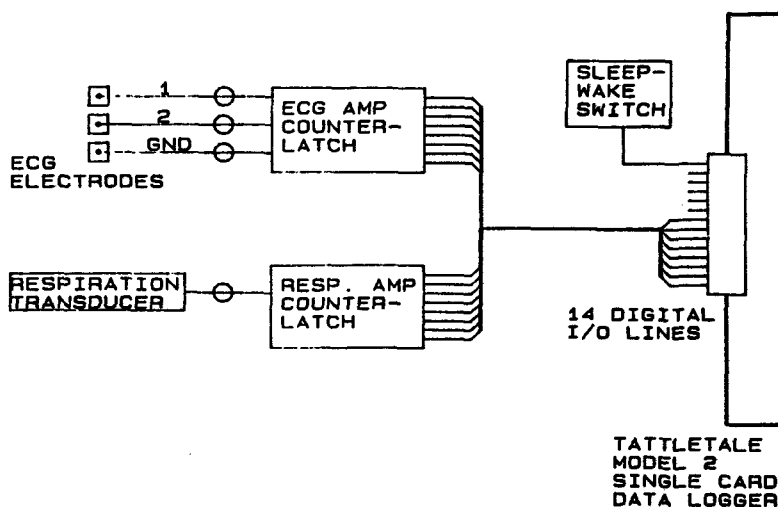

Figure 4. Block Diagram - Digital Circuit Board.

The Flow Rate channel measures the subject's swimming speed. It is measured by a velocity probe, Mead HP-301, mounted on the logger's housing, which consists of a delrin turbine mounted in a protective shroud. The turbine, when immersed in a flowing stream, rotates at a speed in direct linear

relationship to the fluid velocity. A small magnet sealed within the turbine hub produces an electrical pulse in an adjacent induction transducer for each rotation. The frequency of these pulses is a direct measure of the fluid velocity. The pulses are integrated into a flow signal level which goes to the analog-to-digital converter for storage in data memory (Fig. 3).

These four data items are stored in a known sequence in a single data file called the sequential file. The basic sampling interval is jumper-selectable and was set at 800ms. Thus Depth was sampled every 800ms, Swimming Speed every 1.6 sec, and Sea Temperature and Skin Temperature each every 3.2 sec. The remaining two data items were stored each in a separate data file, and sampled as they occur.

The Heart Rate channel measures heart rate by storing a number that is in a counter when a heart beat occurs. The 8-bit counter is incremented every 10 milliseconds. Specially designed ECG electrodes are applied to the subject's chest. The signal is amplified, filtered, and converted to a pulse. With each pulse, the number in the counter is stored in the section of data memory allocated for heart rate (Fig 4).

The Respiration channel operates much the same as Heart Rate channel, except its 8-bit counter is incremented every 100 milliseconds. A specially designed strain gage transducer is attached around the chest with an elastic belt to monitor chest movement. With each exhalation a pulse is generated, and the number in the counter is stored in the section of data memory allocated for respiration rate (Fig. 4).

A sleep-wake switch is implemented to switch between the sampling-storing mode and a low-power dormant mode to save memory space and battery power.

The Data Memory space is allocated as follows: 100K for Sequential data, 100K for Heart Rate data, 24K for Respiration Rate data. The Logger ignores new data after data memory is full. There is enough storage space at the stated sampling rates for approximately 11 hours of continuous recording.

A PASCAL program has been written which permits the investigator to scroll through the data (in graphic form) and observe on the lap top screen the profiles of the pressure, heart rate, respiration rate, swimming speed and temperature changes that occur during the diver's work day. Another program also has been written which prints out that data in numeric form.

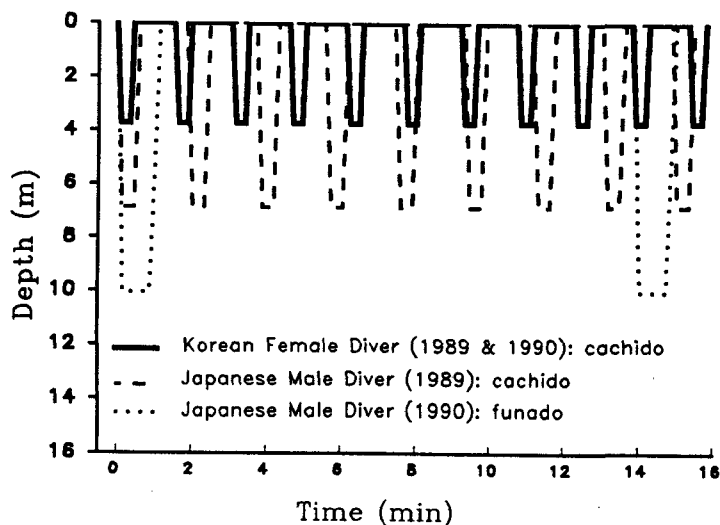

Figure 5. Depth - Time profile of dive performed by Korean female cachido, Japanese male cachido and Japanese male funado divers.

### Diving Pattern of Korean Female and Japanese Male Divers

Figure 5 shows depth-time profile of 11 Korean women breath-hold Cachido (unassisted) divers and 4 Japanese male breath-hold Cachido divers and 4 Japanese male breath-hold Funado (assisted) divers obtained during August-September of 1989 and 1990 in their natural diving ground. Over a period of 16 minutes, Korean female Cachido divers made 11 dives to a depth of slightly below 4 meters, each dive lasting approximately 30 seconds. In contrast, Japanese male Cachido divers made, over a period of 16 minutes, 9 dives to a depth of 7 meters, with each dive lasting nearly 40 seconds. These findings indicate that male Cachido divers of Japan dive deeper and longer than female Cachido divers of Korea. Moreover, the pattern of diving is markedly different between Japanese male Cachido and Funado divers. The Funado divers dive to an average depth of 10 meters, with each dive lasting nearly 70 seconds. However, it is clear that Funado divers make only 2 dives over a period of 16 minutes, and thus the total bottom time per day, in Funado divers, was only 1/2 of that of Japanese male Cachido divers.

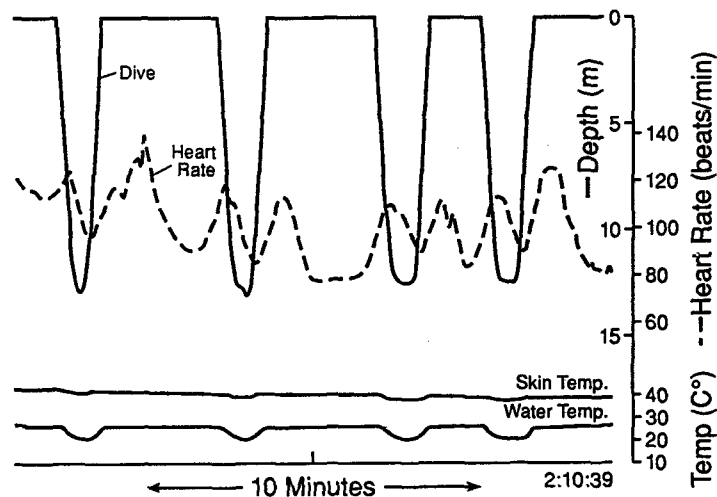

Figure 6. Typical record obtained from a Korean female divers illustrating depth, heart rate, skin temperature, and water temperature changes during a 10 minute segment of record.

Various physiological functions such as Heart Rate and Skin Temperature are currently being analyzed and will be presented at future meetings.

A typical example of changes in Depth of dive, Heart Rate, Skin Temperature and Sea Water Temperature during a 10 minute period of breath-hold diving by a Korean diving woman are shown in Fig. 6. One can readily see that this diver made 4 successive dives to a depth of approximately 12 meters, each dive lasting approximately 50 seconds. The Sea Water Temperature decreased from approximately 26 degrees C at the surface to 20 degrees C at a depth of 12 meters. Perhaps as a result of this thermocline the skin temperature underneath the wet suit also showed a slight decrease by approximately 1 degree at depth. Also note that each dive is accompanied by the so-called "diving bradycardia". This record does not show changes in the Respiration Rate and the Swimming Velocity; these measurements were not successful because of some noise and motion artifact and the records were too inconsistent and unclear to be acceptable.

Fig. 7 shows a typical diving pattern of a Taiwanese surface-based compressed air diver. Over a period of 140 minutes, the diver made 3 short dives to 15-20 meters and 2 long dives to a depth of approximately 10 meters. While the diver was in water of approximately 10-20 meters in depth, the skin temperature under the wet suit decreased to about 30 °C.

Taiwan Diver 01 (1990)

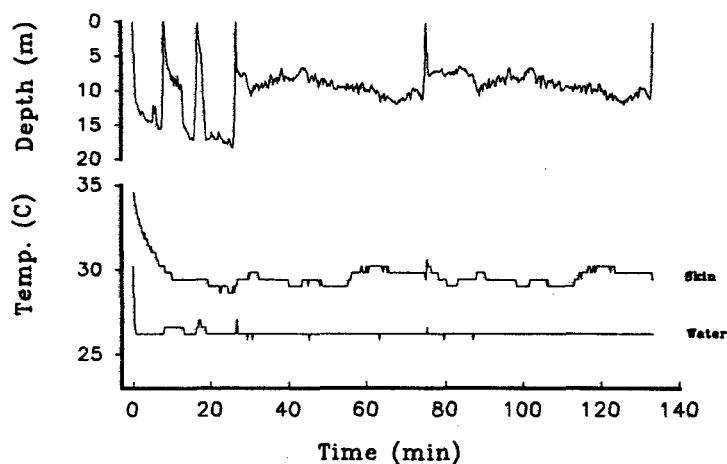

Figure 7. Typical record of compressed air scuba diver illustrating the changes in depth, skin temperature, and sea water temperature during entire work shift.

**Acknowledgements**

The authors gratefully acknowledge the Max and Victoria Dreyfus Foundation, Centers for Advanced Technology Program of the NYS Science and Technology Foundation, and the Margie R. Matthews Memorial Fund for supporting the present work.

## ORCA'S DELPHI DATALOGGER

*Paul A. Heinmiller*  
Orca Industries, Inc.  
10 Airport Way  
Toughkenamon, PENNSYLVANIA 19374 U.S.A.

ORCA's Delphi Dive Computer contains a datalogger as a direct result of the 1988 AAUS Dive Computer Workshop. Although not as flexible and powerful as a dedicated, stand-alone datalogger, the Delphi DataLogger has one major advantage: it is taken on typical recreational dives by typical recreational divers. As a result, the Delphi DataLogger provides the best opportunity for detailed information on actual recreational dive profiles, including repetitive, multi-level and multi-day exposures.

### Design Objective

Our objective in the design of the datalogger was to make it an integral part of the Delphi, able to recreate a dive envelope that only slightly overestimates the exposure of a typical recreational dive, with total storage equal to the dive time of an above average diving week on a live-aboard dive boat. The ability to set non-standard sample intervals during production was designed-in to allow us to meet the needs of institutions and research programs that may have other objectives.

The Delphi Dive Computer includes a tank pressure sensor, and is attached to the end of the high pressure hose. It is about the same size as a standard two or three gauge analog console. The Delphi performs normal dive computer functions, including scrolling no-decompression limits and air limits on the surface, no-decompression limits and air limits in no-decompression mode, and total time to surface and ceiling depth when in decompression mode.

### Data Collection

Depth is stored every 2.5 minutes during the dive in the standard Delphi. Periods of less than the sample interval are stored as full intervals. The recorded depth is the maximum depth for the previous sample interval, stored to 0.5 fsw resolution with an accuracy of 1.5 fsw. Status flags written with the diving sample include ascent rate violations during the interval and the most extreme decompression mode during the interval; no-stop, less than 5 minutes remaining in no-stop, decompression stop required, or decompression stop violated. If the unit stopped recording due to a dead battery, that is also noted with a status flag.

Although there is no real-time date/time marking of data, repetitive series retain internal time continuity. Independent establishment of any time point can be used to back-annotate the entire profile. Time spent between repetitive series, after the Delphi has turned off upon reaching surface saturation, is unrecorded. Therefore, in the data, there is no way to tell when a previous repetitive series was executed, merely that it exists.

Surface intervals within a repetitive series are recorded as an integer multiple of the basic sample interval, rounded down. In the standard units, surface intervals as short as 3 seconds are marked, even though the basic interval is 2.5 minutes.



The basic sample interval is fixed during production, and is not alterable in the field. The default sample interval is 2.5 minutes, but intervals down to 15 seconds are available by special order. The total storage space is fixed. The total length of the stored data is 860 times the sample interval, 35.8 hours in the standard units. Shorter samples result in shorter overall records, as shown in Figure 1.

<u>BASIC DIVE PERIOD</u>	<u>CUMULATIVE DIVE TIME</u>	<u>SINGLE SAMPLE MAXIMUM SURFACE INTERVAL</u>
2.5 MINUTES	35.8 HOURS	85.2 HOURS (STD VALUES)
1.0 MINUTES	14.3 HOURS	34.1 HOURS
0.5 MINUTES	7.2 HOURS	17.0 HOURS
0.25 MINUTES	3.6 HOURS	8.5 HOURS (NOAA UNITS)

SAMPLE RATE FIXED IN PRODUCTION, UNALTERABLE

860 SAMPLES AVAILABLE

ONE SAMPLE PER BASIC DIVE PERIOD

ONE SAMPLE PER SINGLE SAMPLE SURFACE INTERVAL

TWO SAMPLES PER WAKEUP FROM OFF

TWO SAMPLES PER TANK TURN-ON AFTER OFF

Figure 1. Custom Delphi sample periods.

### Data Storage

The data is stored in non-volatile electrically erasable programmable read-only memory (EEPROM). It is retained through indefinite unpowered periods. In the event of the destruction of the Delphi, the data is retained if the chip can be recovered intact. At the end of the 35.8 hours maximum storage (at standard sampling), the oldest data is written over. The Delphi can serve as a "black box" dive recorder, always containing the latest 35.8 hours of profile information.

### Data Retrieval

Data can be retrieved through either optical or electrical data links to a personal computer. The Orca DataReader implements the electrical approach. Manual retrieval of detailed dive profile information is not possible. Data retrievals are non-destructive, but multiple turn-ons will write over the oldest data, three samples for each turn-on and turn-off. Error checking is the responsibility of the receiving and translating software, Orca's program confirms proper datafile structure, but cannot verify content. Multiple retrievals could be used to verify content, but since the only way to write to the datalogger is by additional dive time, content checking was considered unnecessary if proper file structure was present.

### Data Conversion/Transfer

Orca's retrieval and translation program produces three types of output file:

#### Security File.

This is the basis for further processing and file transfers. This is a 2192 byte binary file with row, column, and total checksum error detection. The file is not alterable by typical word processor data manipulation. Data is stored as an exact binary version of the retrieved Delphi data. This is the only file type that should be accepted for data transfer, as the other types are easily altered.

### Simulator File.

This file is produced from the security file, this ASCII text file contains time-depth pairs and text flags. A maximum of 860 lines long, successive samples at the same depth will be combined to shorten the file. This file is intended to be used as input data to a dive simulator or profile analysis software.

### Spreadsheet Import File.

This file is produced from the security file, this ASCII text file contains one line for each depth interval. Surface intervals are expanded to one line for each sample interval. Status flags are expanded into additional text columns. This file is intended to be imported to a spreadsheet program in the "comma, quote delimited" format. Graphs of dive profiles are easily created, see Figure 2.

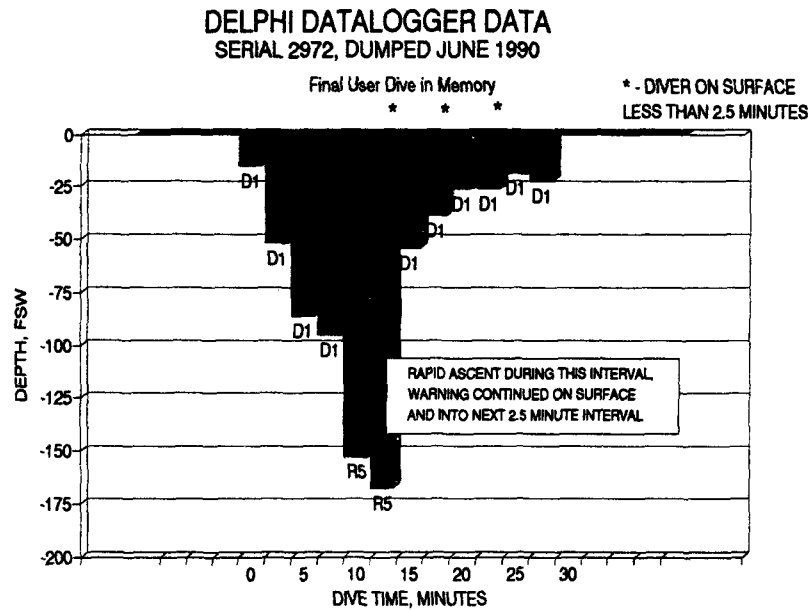

Figure 2.

The software supplied with the DataReader can produce simple screen and printer plots for inclusion in logbooks. Experienced users can create customized graphs using readily available spreadsheet programs. Detailed analysis of the database will be limited, at the beginning, to Orca and the Diver's Alert Network. Programs currently under development include data expansion from the security file and elimination of duplicate/overlapping data. Room for header information will be based, in part, on the results of this workshop. Access to the database for other users will be available as soon as structure and programming questions are resolved, and programming is completed.

### Availability

Delphi Dive Computers are available now (March, 1991), and have been shipping since November, 1989. Suggested retail price is \$670.00. The Orca DataReader will be available to dive stores, institutions and researchers during the second quarter of 1991. Retail price is around \$500.00, and will include the data retrieval and conversion program. Future release of more sophisticated and comprehensive software is expected.

### **Current Database**

Orca presently has about 300 data retrievals stored on disk. Ten to fifteen have been converted, for the purpose of software development, bends case analysis, or special interest. Other than the diver's name and unit serial number, no header data is included. No overall analysis has been applied to the existing data, as the computing power required exceeds that presently available at the factory.

It is quite apparent from the small quantity of data presently collected, that full-scale collection and analysis of the volume of data expected will require major computing resources and manpower.

We hope that Delphi data will prove useful to professionals involved in the various aspects of decompression research, and expect to incorporate the results of this and future conferences as improvements in future designs.

## DAN ACCIDENT REPORTS

*Joel Dovenbarger*  
 Divers Alert Network  
 Box 3823  
 Duke University Medical Center  
 Durham, NORTH CAROLINA 27710 U.S.A.

Recreational diving differs from commercial and scientific diving which occurs under well controlled circumstances with individuals who are motivated to complete specific tasks. Recreational divers, on the other hand, generally dive for leisure activities such as sightseeing, spearfishing, photography, cave or wreck diving.

There are approximately 550 to 650 reported cases of decompression sickness and arterial gas embolism each year. There were 678 treated cases reported in 1989 representing an increase of 23 percent over 1988. However, diving injuries were down 8.1 percent from the year before. When averaged, these figures represent an approximate increase of 7.7 percent in dive accidents per year. Although the exact number of active recreational divers is not known, it may total as many as 2.7 million. The approximate incident rate would be 2.5 injuries per 10,000 participants in 1989. In cases studied by DAN, 16 percent of all divers injured (DCS and AGE) continued to dive after they had their first symptom of decompression sickness. Fifty percent of all divers delayed seeking assistance for 12 hours or more. In 1988, statistics were similar showing 17.5 percent of divers continuing to dive after their first symptom and 48.5 percent delaying to seek assistance for greater than 12 hours post onset.

Computer diving has become very popular with recreational divers and thousands of units are being used today. Fifteen percent of divers in the 1987 accident report were using computers compared to 31 percent in 1988. In 1989, 32 percent of all injured divers were using computers. This seemingly sudden increase in computer-related accidents has led many to believe computers are not safe for recreational divers and may lead to accidents.

Table 1. Dive Computers and U.S. Navy Table Comparison.

	1989		1988	
	Table	Computer	Table	Computer
>80 Feet	38.5%	81.0%	67.0%	81.0%
Square Profile	53.2%	28.6%	61.0%	42.0%
Multi Day	48.3%	52.4%	48.0%	55.0%
Repet	58.5%	73.0%	57.0%	81.0%
Single Day	51.7%	47.6%	52.0%	45.0%
TOTALS	n=265	n=126	n=184	n=84

Table 1 demonstrates a comparison between computer assisted divers and those who use a dive table to calculate their profiles. The U.S. Navy Tables are still a standard decompression table, and are the only tables used in this comparison. Computer divers are more likely to begin their dive at 80 feet or greater and perform more multi-level and repetitive dives than do table users. These diver preferences are allowed within the parameters of dive computers. Divers may very well select themselves out of table use because they prefer this style of diving. There is seemingly very little difference between

single day and multi-day diving among table and computer users. Since dive times are calculated differently for table and computer dive limits, no comparisons were made for this analysis.

A comparison of decompression illness with table and computer users is made in Table 2. There are more instances of pain only (Type I DCS) in computer users, neurological (Type II DCS) is about the same in both table and computer users, but arterial gas embolism occurs three times more often in table users than in computer users. These differences have become more apparent after only three years of data collection and the overall increase in total accident cases.

Table 2. Dive Tables vs. Dive Computers.

	1989		1988		1987	
	Table	Computer	Table	Computer	Table	Computer
DCS Type I	18.5%	31.0%	21.2%	31.0%	15.7%	26.8%
DCS Type II	64.9%	63.5%	60.3%	60.7%	63.8%	61.0%
AGE	16.6%	5.5%	21.2%	8.3%	20.5%	12.2%
TOTALS	n=265	n=126	n=184	n=84	n=229	n=41

Since dive times are calculated differently for tables and computers, the mean, median, and range of five of these dives was not figured in this comparison.

It would seem that a difference could perhaps be detected in the severity of injury or diagnosis of the diver if the computers were inherently more dangerous than tables. In this small sample group, computers seem to have a decrease in one of the most severe diving injuries, arterial gas embolism. This may be due in part to a certain measure of control a computer offers over the dive. A computer diver may start his dive deeper than he intends to stay by using the multi-level calculation feature of a computer. This adds a certain measure of control for the diver because he has more time in which to perform his dive and can end it at a shallow depth.

The overall numbers presented are small and at this time no conclusion can be drawn regarding which means of dive planning is safer. Six computer divers out of the 126 reported for 1989 had some problems with their computer. Five of these six cases involved an apparent computer malfunction. The other case involved a flooded computer battery compartment. All divers continued diving after they experienced a computer problem.

The most important component for DAN in the development of dive profile recorders would be the availability of accurate time and depth data. Ideally, this information would be used in conjunction with the personal preferences found on the DAN accident reporting form. Together, these two sources of information would be combined to give more accurate detail for the associated dive attributes in decompression sickness.

### Dive Recorder Session Discussion

Karl E. Huggins, Moderator

- K. Huggins: What has been done in terms of gathering the dive profile database together in some coherent organized manner and what, if any, conclusions have you made from reduction of the data that we could stick in for possible recommendations for repetitive diving? Has anybody at this table done enough analysis of profile data on repetitive diving to be able to say that there are conclusions and recommendations that they can make at this time based on their data?
- B. Oliver: The only conclusion I have is I need a bigger computer and a bigger staff! It is my understanding that our data was sent to DAN and we made no attempt to draw conclusions or collate the data. Actually, we were overwhelmed with the response, we had far more data than we could analyze.
- R. Eckenhoff: Did you make any attempt to try and normalize those incidences that you had to what is out there in terms of number of diver dives with and without computer?
- J. Dovenbarger: We normalized the total population and compared it to a random population that we have that was selected in 1989, and, the fatality population. We can say that it fits in the curve. Specifically for computer use, no, we did not. That is a difficult thing to do, you are right. That is why I suggest that what we really need is a black box trial where we have a black box. We get this type of information on the divers, the handwritten information and to that, we can attach some very exact and accurate data like tank pressure, ascent rates and surface intervals.
- R. Eckenhoff: Can the manufacturers give us any kind of idea of what percent of man dives in the recreational community are being done with computers?
- P. Heinmiller: Some of the surveys that are coming out, including the live-aboard and resort survey that PADI did, indicate 30 to 50 percent of people on travel are using computers.
- C. Fife: You had asked us to outline something that we need and I discovered that we need to know the depth and time, but we also need to know about the ascent rates. I did not realize how important that was until we did our long-term project. However, with a recording interval of three minutes, you cannot get that information. In fact, you cannot even get the information on descent rates when we need to take 60 seconds to go 140 feet. I wonder if you have any plans to incorporate some way of measuring ascent rate. I realize the trade-off is going to be you have to sample every few seconds and that may not be a valid alternative.
- P. Heinmiller: As far as a speedometer, we do not have any plans to put a speedometer into the dive computer. But, we do mark excessive rates.
- B. Oliver: In the case of the Suunto instrument, we know when it exceeded 33 feet per minute at which point in their dive.
- J. Henderson: With our logger, we were able to graphically find the slope because our sample rate was 800 milliseconds for the depth. We also attached that flow probe, expecting to see a correlation between the swimming speed on the way down and up, matching the slope of the depth. But, that did not work out that way. There were other problems with that flow probe.
- C. Fife: For Doppler research, I think that is the kind of information that we need in addition.
- P. Sharkey: While you guys are working at the extreme of the amount of information that can possibly be packed into these recorders, from a diving officer's perspective I would like something a little lower tech. An instrument that checks up on divers by giving us maybe nothing more than max depth and total dive length and maybe holds a hundred of those.
- B. Oliver: That is a function in the Suunto Solution. If you choose not to read out the dive profile, you can take the short form and get the max depth and time, a log book entry.
- J. Dovenbarger: One of the problems that I have certainly been frustrated with in collecting dive statistics is that you can come up with some very believable statistics, but the fact of the matter is there are many alternative explanations to any particular event. When we talk about acclimatization, are these people becoming acclimated to a certain depth and time? Unless they

are also consistently keeping safety measures such as rehydration on any particular day, you fall down on the safety scale as you become more dehydrated on the tenth or fourteenth day. There is no way to monitor that. In the middle of your month-long dive series you also are fatigued and now you have this dehydration working against you. That is the day that your luck runs out. There are so many possibilities that we would need about a hundred replicates to do that. That is why I would suggest that there is some paper trail that we can follow on these individuals, as well as accurate profile recorders.

- P. Sharkey: Well, what we were wondering about is some kind of an instrument that would tell us how accurate the paper trail we have is, something that was less than \$600 and simply constructed.
- P. Heinmiller: The data analysis from the Delphi or the Suunto in the computer could tell you that information. The reason the computers have the profiles in the first place is because it is a simple maximum depth - bottom time characterization of the dive. A computer multi-level dive tells you absolutely nothing about what happened, so, you really need much more data. That is why we did this in the first place. You could always simplify it, but I do not know why you would want to.
- M. Lang: In our academic environment where we are trying to educate and disseminate information to our diving population, we now have an irreconcilable difference in that one knowledgeable body of experts told us not to fly until 24 hours have elapsed after diving, and our trusted dive computer says it is safe to fly in six hours. How do you propose we reconcile those numbers for our divers?
- P. Heinmiller: Just like the Navy tables, we know we have a finer detailed information about what the diver did, so for UHMS to come out and say wait 12 hours, if you log less than two hours under water and wait 24 if you log more than two hours in the previous 48 hours, that is great! Our computer time to fly calculations are along those lines, just like they are along the lines of a reduced Navy table. But, we know where that time was spent, not just that it was under water, so we will change it accordingly.
- B. Oliver: Our computer operates by not allowing you to fly until desaturation is completed. We probably will not exceed those 12 hour and 24 hour recommendations anyway.
- K. Huggins: I think that largely depends on the exposure of your dive in terms of what the desaturation time will be before the various units allow you to clear and fly.
- J. Dovenbarger: You have to remember that that is a very inexact type of measurement. We should, theoretically, all be clear at 24 hours or 12 hours depending on your exposure, which is the basis for that, but along the way there are many, many things to consider, such as individual variances that we cannot account for no matter how good we make the computer. That is reason for a very conservative approach to flying after diving.
- J. Lewis: In terms of the UHMS recommendations on flying after diving, the one thing that is really great about those proceedings is an appendix by Dick Vann. If you really want to take a look at the data sent, I have never seen anything that put it altogether in one spot, but the conclusions of that particular workshop have absolutely nothing to do with the scientific evidence that was presented there. I do not know where those conclusions came from. A particular example has to do with the statistics of the time delay. There were every bit as many hits in the first 12 hours as there were between 12 and 24 hours and all of a sudden these recommendations came from outer space. I comment on that to reply to Michael's question. Despite all of the obfuscation, you are going to have a wide, wide range of what the dive computer is going to be telling you to do. I would like to hope that this particular group does not fall into the same pitfall as the UHMS group did.
- M. Lang: I will address that later.
- R. Coley: As a manufacturer trying to analyze exactly what everyone is looking for, is there truly an interest in dive profiles on dives without incident? This goes back to a program that we instigated where we collected hundreds of dives without incident to give us an idea of what the average diver's pattern was like. But, it seems that that kind of information really is not something desired right now.
- K. Huggins: I disagree, I would like to see that information.
- R. Vann: We really appreciate all the data that you sent in and it is very important. The problem is entering these data is tremendously labor intensive. Indeed, you must know the safe dives as well

as the dives in which decompression sickness occurred in order to estimate the risk of decompression sickness. Manual entry of data from the original Suunto is difficult. The newer computers, the Solution and Delphi, are going to get around the problem of data entry. Our ultimate goal is to do a risk analysis on DCS data that comes back from the DAN chambers as well as many dives with no DCS. Statistical analysis may allow us to estimate the risks of decompression sickness. If Suunto and Orca can send us the data in usable form, I think that will be a big step forward.

K. Huggins: I think that we have got some of the resources here because Russ was talking about the database that is already out there and in existence that may be able to be modified. Dr. Gotoh talked about some of the data compression and transmission possibilities. So, we have the resources up here to be able to start work on that.

R. Nishi: If we want to get data to actually analyze risk analysis, we have to get it in more detail than three minutes, especially if there is a bend on it because you need that really accurate profile to find out exactly what the gas loading was. If there was no bend on it, maybe it is not as critical to track information that closely, but we still would like to get that as accurate as possible.

R. Peterson: What sort of tolerances would you like to see as far as time and depth and so forth?

R. Nishi: I would like to be able to track it pretty accurately when your depths are changing. If your depths are not changing, you can take 15 minute intervals, but as long as the depth is changing we would like to get it within a meter per minute.

R. Peterson: What sort of depth change would you consider to be significant, or what sort of change would you not consider to be significant?

R. Nishi: About 0.3 meters, one foot.

J. Chimiak: Regarding the AGE hits, was that normalized to the experience of the diver?

J. Dovenbarger: I believe I did it by single day, multi-day. I am not sure if I did it by computers.

J. Chimiak: The reason I ask is that the normal diver with a dive computer is generally going to be more experienced, as opposed to an inexperienced diver, where you are going to see most of your AGE hits. Whether those guys had a computer or not, they are still probably going to experience an AGE.

J. Dovenbarger: There are more AGE cases in the less experienced population, that is true. I think it approached 50 percent or something like that with the majority of them being spread out. People who chose computers, self-selected themselves for that, so there is some element of self-selection in that figure that we cannot account for anything but theory, I suppose.

J. Chimiak: For the database itself, there are two times that actually have to be recorded post-dive. One is the time where the diver completely feels well. The second time is when the diver is bent. The reason for it is the time interval in between. T1 and T2 will be the period of uncertainty. This is going to be important in actual table development, so if we could get that entered into the database it would be very important.

G. Egstrom: If these dive computers are so good at telling us about how we are on-gassing, why can they not tell us about off-gassing? They should be able to tell us when we can fly within the same kind of limitation they have that tells us when we have got to decompress, should they not?

R. Vann: Only if data is available.

P. Bennett: That is correct.

R. Peterson: That question really has not been studied as thoroughly as decompression. Again, we do not know all the real mechanics of decompression. We have learned to deal with them, albeit in a trial and error way. There simply is not as much experience with flying after diving. There has been a study that was done on some NASA data by the Ocean Systems group some years ago and I haven't seen anything near as exhaustive as that any place else. That's the only thing that I can think of.

G. Egstrom: The data that we do not have has been mentioned and the decisions that we have made about 6, 12, 18 and 24 hours, seem like the Woolworth effect: Everything has got to finish on a five or a ten! I cannot believe that we are not more sophisticated than that with the information that we have within the machinery.



- K. Huggins: Computers are just running through the half-time accumulation and elimination in the compartments and, based on specific decisions made in the design of the computer, as to when the level in those compartments is safe to be taken up to approximately 8,000 feet. That is what they are using for the off-gassing.
- M. Emmerman: Do you remember the case of the 54 year old male in Australia? It was a "computer case" because he was wearing a computer! The man never looked at it, never used it! Did a case like that end up in the database as a computer related hit?
- J. Dovenbarger: That particular case, since there was no follow-up, it was insufficient data. That case would not have ended up in the database, not because he was "using a computer", but because we did not have a complete set of data to put him into the database. If I had had complete data, he was an American citizen, diving, we probably would have put him into the data set because he was diving with a computer. But, that is the atypical example.
- K. Huggins: Out of what you have seen of profile recorders, what would you consider minimal information for your operations? I know it is going to be different for the different type of operations you are doing: commercial versus scientific versus recreational. Is there anything that has been presented that you would like to see in some of the less sophisticated computers, necessary for your type of operations?
- R. Hamilton: About the point of how often we have to record depth changes may I suggest that the recorder monitor rather frequently depth versus time and when there is a sharp change it puts in a rate somewhere else. Every three minutes to me seems for most kinds of diving quite adequate if it gave you the average of that period, rather than the peak, which everybody recognizes is artificial. If you could then store the rapid changes of depth somewhere else so that you can make your normal slices of depth much larger, you could do this much more efficiently. The way to make this is for the computer to do the processing at the time the data is observed. It is going to have to look every one or two seconds in order to get this information. We have struggled with this with pressure chambers, for example, if you are going to record what is going on in a chamber. How do you do rate? We do not have a good way of dealing with it. You have to deal with rate and depth as two separate items.
- R. Peterson: Not necessarily, Bill. I think the way the Jotron unit works, in essence, it gives you that. If there is not much of a depth change, you have a point. You might have one point every hour, if there is not much, but if there is considerable change, you will get it every five seconds or every one second.
- D. Dinsmore: From our standpoint, I think we have two different types of information we would like to have. One, operational type of information, depth, time and pressure in the tank. On the other side is the oceanographic data, dissolved oxygen, CTD information, which can be used for the scientific aspect. We would love to have it both ways and be able to plug in more sensors to make it truly a data collection for science.
- P. Bennett: I think if we had depth, time and rate, I would be very pleased. If it came in every minute, I would be very happy indeed. We cannot even seem to get that. I am even more concerned because there are 24 computers out there, all with different algorithms and all are going to have nice little data relief functions to come onto our computers. That is a tremendous amount of information which we have to analyze in conjunction with level of hydration, exercise before and after the dive, the frequencies of diving and so on. I do not know whether we are going to solve this tremendous problem. My concern always comes down to a practical issue regarding DAN and divers out there. The fact is that the computers were brought in as the Holy Grail to save divers. We were going to get perhaps less bends. We do not seem to be getting that. In fact, we have had more this year. Computers are showing a rise. Gentlemen, what can you do to help this trend reverse?
- P. Heinmiller: I disagree. Joel's data did not show a rise. Both groups increased by 50 percent between 1988 and 1989 and the proportion of computers to total numbers...

- P. Bennett: I agree with you they both rose, but I would hope that computers by being more elegant would show a decline.
- P. Heinmüller: I agree it would be nice!
- K. Huggins: One thing that is required for any of the profile information is very good header information regarding the individual involved and the circumstances with that information, particularly if there was a decompression sickness case associated with it.
- D. Richardson: On the delay in treatment for the recreational divers, of serious concern, are the patients queried relative to operational restrictions such as remoteness of the location and also the human factor or denial of symptoms? Are they questioned to that effect?
- J. Dovenbarger: That raises a whole lot of questions. It is not a simple answer. The statistic that I gave is call-for-assistance, not recompression. That means that they did not call, so there was a 12 hour period where they perhaps thought about it. I am not sure that it is denial as much as it is failure to recognize the symptoms of decompression sickness. We record 30 symptoms we consider as initial presenting symptoms. I do not know if you can sort that out. Yes, there is denial. Is denial more of a factor than lack of recognition? I do not know. Pain, for instance, is the most common first symptom. In this group, there are 154 cases where pain was the first symptom. That does not necessarily tend to argue for them denying, but rather how they are going to differentiate pain as the only symptom from everything else? The other symptoms of numbness, tingling and weakness that we consider serious symptoms come on as secondary symptoms, more prominent than pain. When we list unconsciousness, paralysis, seizures, semi-consciousness, which everyone recognizes as a serious problem regardless of what it relates to, those people in the accident management data, almost 17 percent, display one of those serious symptoms. If we put it on a spectrum and we use this one-to-six severity code, the vast majority of people that are down in the one-two-three category where they might have some numbness and tingling, sure, I think that there is some denial there, but those people are the ones that tend not to report. For true denial, you have to have some previous experience. Otherwise, there is no motivation for them to think that it is decompression sickness.
- D. Richardson: I was just thinking in terms of heart disease, where it is pretty common to deny the onset of heart attack symptoms.
- M. Lang: As today's closing comment regarding the issue of recommendations I wish to reassure those diving officers who have come to me and said, "We're never going to get anything out of this", as well as those of you who have issued a concern that where there is no data, there should be no recommendations. I can assure you that in past AAUS workshops I have chaired, and many of you have been to either one or two, we made a very judicious effort to first, get a consensus from the group before anything went to print and second, to state that if we do not have the information, not to make a recommendation. Case in point: "Multiple deep dives require special consideration", if you remember that from the dive computer guidelines. I take this opportunity to thank the various diving communities helping us today, especially the commercial people with their extensive experience, the manufacturers again, the recreational training agencies and DAN, and the scientists.

## DECOMPRESSION PHYSIOLOGY

*Richard D. Vann*  
Box 3823  
F.G. Hall Hyperbaric Center and  
Department of Anesthesiology  
Duke University Medical Center  
Durham, NORTH CAROLINA 27710 U.S.A.

*The pathophysiology of decompression sickness (DCS) is as varied as its signs and symptoms. While there are many uncertainties concerning this pathophysiology as well as the physics and physiology of bubble formation and inert gas exchange, it is increasingly apparent that bubbles in tissue are a normal occurrence under many circumstances and that factors which influence their formation and elimination are important determinants of DCS risk. Experiments are described which are helpful in distinguishing between competing hypotheses concerning bubble formation, inert gas exchange, and pathophysiology. These hypotheses can be used to formulate decompression models, analyze decompression data, and perhaps predict low risk decompression procedures.*

### Cardiopulmonary Decompression Sickness

Paul Bert's animal experiments in the late 19th century demonstrated that bubbles are the cause of the most serious forms of decompression sickness (Bert, 1877). These experiments and autopsies of 19th century divers who died from acute DCS showed that the cause of death was cardiovascular collapse resulting from a massive influx of venous bubbles into the heart which prevented blood from returning to the lungs.

A somewhat less spectacular but still potentially fatal consequence of venous bubbles entering the lungs is pulmonary DCS or "chokes". Chokes usually begins with a sore throat and can progress to paroxysmal coughing with severe chest pain. While chokes can be rapidly reversed by prompt recompression, untreated chokes can lead to edema, pulmonary hypertension, and respiratory insufficiency. Pulmonary DCS was a contributing factor in a number of deaths which resulted from altitude exposure (Dixon, 1991).

### Neurological Decompression Sickness

Fatalities due to cardiovascular collapse or chokes are avoided today by limiting dive depth and bottom time and by decompression stops which wash out inert gas before bubble growth becomes excessive. Nonetheless, after many dives, the venous blood carries some bubbles to the heart, and these can be readily detected by ultrasound (Powell *et al.*, 1982). Bubbles are commonly present in the right atrium and right ventricle but are less frequent on the left side of the heart because the lungs are a reasonably good filter for both gaseous and solid emboli.

The brain is the principal target organ for both solid and gaseous arterial emboli (Hallenbeck and Andersen, 1982), and one might expect cerebral symptoms to be common if arterial bubbles were present after decompression. This is certainly true in the case of arterial gas embolism following pulmonary

barotrauma, but the infrequency of cerebral DCS as compared to spinal DCS suggests that arterial emboli are unusual if the lungs are not damaged.

Arterial emboli can result, however, if the volume of bubbles entering the lungs with the venous blood exceeds the lungs' filtering capacity. Repetitive diving also promoted the passage of bubbles through the lungs of mice and guinea pigs (Gait *et al.*, 1975) and was found to be a reliable means of producing spinal DCS in goats (Hills, 1971) and dogs (Sykes and Yaffe, 1985).

Another means by which venous bubbles can enter the arterial circulation is through defects in the wall which separates the chambers of the heart. Studies by Moon *et al.* (1989; 1991) and Wilmshurst *et al.* (1990) provide statistical evidence suggesting that both cerebral and spinal DCS are more common in divers with heart defects.

While interesting, the arterial gas embolism hypothesis needs further study. Francis *et al.* (1989) injected bubbles into the arterial circulation of the spine in dogs and found these emboli to be distributed to the gray matter rather than to the white matter where spinal DCS lesions are typically seen. These dogs, however, had not been previously exposed to compressed air which would have supersaturated their spinal cords with nitrogen.

Neuman and Bove (1990) pointed out the possible consequences of such supersaturation in a review of severe spinal DCS which was precipitated by arterial gas embolism secondary to pulmonary barotrauma. Arterial emboli would grow while passing through supersaturated spinal tissue and could cause venous stasis and perhaps produce the typical white matter lesions of spinal DCS. This hypothesis is relevant to the question of whether venous bubbles are a hazard to the spinal cord if they enter the arterial circulation. If this is true, decompression procedures should be designed to produce only minimal venous bubbles.

One further mechanism for spinal DCS is relevant. A bubble formation threshold of about 85 fsw was found for the spinal cord of dogs in studies where the spinal circulation was arrested prior to decompression so that arterial bubbles could not occur (Francis, 1990). This was interpreted to indicate the presence of autochthonous or pre-existing *in situ* bubbles which grow upon decompression. Both autochthonous and arterial bubbles might contribute independently to spinal DCS.

### Control of Venous Gas Emboli

How might the development of venous gas emboli be controlled? Figure 1a is from a study in which venous bubbles were detected by Doppler probes implanted around the vena cavae of goats during 20 minute air dives to 220 fsw (Smith, 1976; Smith and Stayton, 1978). The decompression stops in Fig. 1a are according to the U.S. Navy exceptional exposure schedule after ascent at the standard rate of 60 fpm. The stars and circles represent abundant venous bubbles in each of two goats.

When the 220 fsw, 20 min. dive was conducted with initial ascent at 30 rather than 60 fpm, followed by ascent to the surface from 80 fsw at 2 fpm, the incidence of precordial bubbles was greatly reduced (Fig. 1b). In 60 dives using a variety of decompression profiles, venous bubbles were nearly abolished by reduced ascent rates and deeper initial decompression than required by Navy tables. Other studies suggested that a short decompression stop 10 fsw deeper than the first Navy stop might reduce the incidence of precordial bubbles in humans (Neuman *et al.*, 1974; Pilmanis, 1990a).

If venous bubbles are prevented by short, deep stops, the gas in them is probably from tissues which exchange nitrogen rapidly. Avoiding these bubbles in the early stages of decompression (and arterial emboli which might result from intracardiac shunt or transpulmonary passage), could allow sufficient time for a more slowly exchanging spinal cord to desaturate safely. In contrast to bubbles appearing after rapid ascent, bubbles which arise from saturation exposures are delayed in onset suggesting they

originate from tissues which eliminate nitrogen slowly (Eckenhoff, 1991). As spinal DCS is rare in saturation diving, it would appear that spinal symptoms originate in tissues which exchange nitrogen more rapidly than tissues in which pain occurs.

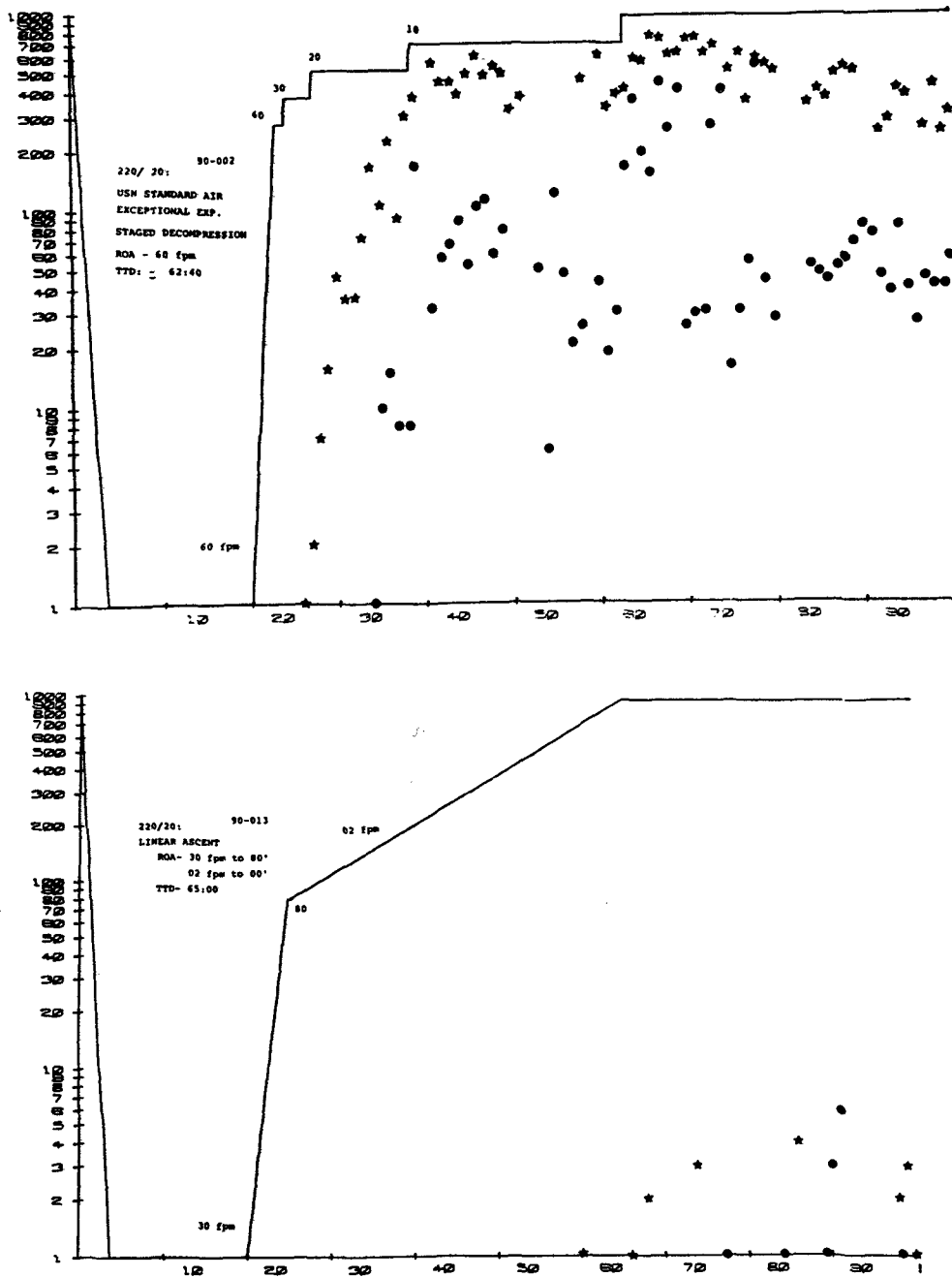

Figure 1. Bubble events in two goats (star and circle) after 20 minute air dives to 220 fsw. Bubbles were detected by Doppler cuffs implanted around the inferior vena cava. The abscissa is time, and the ordinate is the logarithm of bubble events. Decompression profiles are overlaid on the bubble events. (a) Decompression according to the USN Exceptional Exposure Table. (b) Decompression according to a two-phase linear profile.

### Pain-Only Decompression Sickness

The most common symptom of decompression sickness is limb pain. Bubbles are hypothesized to be the initiating cause of limb pain because they are responsible for death in animals and are detected routinely by ultrasound in humans. Establishing a direct experimental link between bubbles and pain has been a problem, however, since detecting or imaging bubbles at the site of pain is difficult. The best images of bubbles in painful joints are from radiographs made during altitude studies, an example of which appears in Fig. 2. This film, taken at an unknown altitude around 1945 by the Army Air Force at Randolph Field, shows an aspherical bubble, approximately 10 cm long and 1 cm at its highest point, posterior to the knee and parallel to the femur (Pilmanis, 1990b). The bubble appears to dissect adjacent layers of muscle and was associated with severe pain at the end distal to the knee.



Figure 2. Radiograph of a bubble at an unspecified altitude made circa 1945 at the U.S. Army Air Force School of Aerospace Medicine, Randolph Field, TX. (Courtesy of Dr. A.A. Pilmanis.)

The relationship between bubbles and pain was addressed by Thomas and Williams (1944) and Webb *et al.* (1944) who exposed subjects to an altitude of 35,000 feet during the Second World War. To hasten the onset of pain, the subjects did five deep knee bends every three minutes. When one knee became painful, both knees were radiographed. Thomas and Williams (1944; 1945) found free gas in the knee joints of all subjects, with or without pain, beginning at 20,000 feet and increasing to maximum volume after about 30 minutes at 30,000 feet. In one subject who was pain-free at 38,000 feet, a 50-75 ml pocket of gas was observed in the supra-patellar bursa. When aspirated, gas in the knee joint was found to contain oxygen, nitrogen, and carbon dioxide in approximate equilibrium with blood. Asymptomatic gas also was observed in the joints of the wrist and hand and in the vaginal sheath of the flexor tendon of a finger. The gas in the finger was easily palpable and milked along its length. Bubbles posterior to the femur in the upper posterior *fossa* were correlated with pain ( $p = 0.007$ ) as were streaks of gas which appeared to be along facial planes or tendons as in Fig. 2 ( $p < 0.000001$ ).

Webb *et al.* (1944; Ferris and Engle, 1951) also found free gas in the joint space or suprapatellar bursa in all radiographs whether or not pain was present. The best statistical correlation between bubbles and pain was for gas in the popliteal fat ( $p = 0.0000008$ ) followed by streaks of gas in the posterior tissues ( $p = 0.00015$ ), bubbles immediately posterior to the joint space ( $p = 0.0021$ ), and bubbles in the infrapatellar fat ( $p = 0.1$ ). The severity of pain and size of the gas lesion were correlated for bubbles in the popliteal fat ( $p = 0.02$ ).

Statistical correlation does not prove causality, and pain might be caused by a mechanism associated with bubbles but invisible to radiography. The observed correlation, however, is strong circumstantial evidence indicating the involvement of bubbles with pain. Webb *et al.* (1944) suggest that pain might be caused by bubbles which distort nerve fibers passing through popliteal fat.

### Bubble Formation

The origin of bubbles in living tissue is uncertain, and much of what is known is derived from study of non-living systems. This knowledge is relevant, however, as one would expect the physics of bubble formation to be the same both *in vitro* and *in vivo*.

Bubbles form as a result of supersaturation. Supersaturation is the excess gas tension and water vapor pressure over the absolute pressure,

$$\text{Supersaturation} = P_g + P_v - P_a \quad (1)$$

where  $P_g$  is dissolved gas tension,  $P_v$  is vapor pressure, and  $P_a$  is the absolute pressure. The probability that a bubble will form increases with the supersaturation.

Bubbles can form *de novo*, from nothing, or from pre-existing bubbles known as gas nuclei. *De novo* bubble formation in water requires gaseous supersaturations in excess of 100 ATM (Gerth and Hemmingsen, 1976; Finkelstein and Tamir, 1985). Bubbles in animals and humans, on the other hand, are detected after less than 0.5 ATM of supersaturation (Dixon, 1985; Eckenhoff, 1991). Thus, bubbles which cause decompression sickness would appear to originate from gas nuclei.

Other evidence implicating gas nuclei is the effect of compression to decrease bubble formation in shrimp (Evans and Walder, 1969; Daniels *et al.*, 1984) and to reduce fatal DCS in rats (Vann *et al.*, 1980). Figure 3 shows that the DCS incidence in rats after a 240 fsw dive decreased from 83% to 74% by a 600 fsw compression and to 64% by a 1000 fsw compression. It is argued that compression produces these effects by dissolving some of gas nuclei.

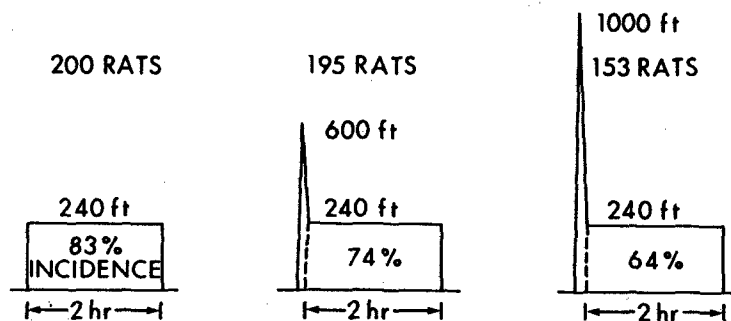

Figure 3. Decompression sickness in rats subjected to pressure treatment before a 2 hr exposure at 240 fsw on air (Vann *et al.*, 1980).

The nature of gas nuclei is uncertain. A small spherical bubble would be dissolved by surface tension and have only a short lifespan. This has led to the suggestion of mechanisms by which gas nuclei are stabilized against surface tension. Harvey *et al.* (1944) proposed that nuclei were gas pockets trapped in solid, hydrophobic crevices in which a concave gas-liquid interface reduced the internal pressure and so prevented gas from dissolving. While much evidence supports crevice nuclei as the cause of bubble formation in *in vitro* systems such as beer, it is difficult to conceive of solid hydrophobic surfaces in protein-lined tissue.

Yount (1982) proposed another stabilization mechanism in which a shell of surfactant material around a spherical bubble becomes impermeable to the outward diffusion of gas as the bubble is compressed. While there is evidence for shell-stabilized nuclei in sea water (Johnson and Cooke, 1981), the validity of this mechanism *in vivo* is questionable as the alveoli of the lungs are lined with surfactant through which gases easily pass. Another troublesome point concerning both crevice- and shell-stabilized nuclei is their formation by self-assembly.

Walder and Evans (1974) suggested a bubble formation mechanism which did not require stabilization against surface tension. They proposed that gas nuclei are spherical bubbles formed during the decay of ambient radiation. While these nuclei (spherical bubbles) would have limited lifespans, new ones would be generated as the old were dissolved. Thus, the creation and destruction of nuclei would be in dynamic equilibrium. This hypothesis provides an explanation for adaptation to decompression in which nuclei are destroyed by daily compression (Walder, 1966).

My own prejudice favors the equilibrium proposed by Walder and Evans (1974) but with bubbles which form as a result of "mechanical" supersaturation. Equation (1) indicates that supersaturation can develop from a reduction in the absolute pressure ( $P_a$ ) as well as from excess gas tension ( $P_g$ ) or vapor pressure ( $P_v$ ). In a hanging water column, for example, hydrostatic tension reduces the absolute pressure at the top of the column, and the resulting bubble formation limits the height to which water can be lifted by a suction pump (Derry and Williams, 1960).

During the negative pressure phase of a sound wave, the absolute pressure can become less than zero and cause acoustic cavitation (Strasberg, 1959). Cavitation also occurs in the lubricant between a journal and bearing as a result of negative pressure caused by viscous adhesion (Floberg, 1964). Viscous adhesion generates negative pressure in any liquid between moving surfaces which are common *in vivo*. The pressure is more negative for small separations and large relative velocities and can exceed hundreds of negative atmospheres (Campbell, 1968; Dowson *et al.*, 1971). These negative pressures may be sufficient to cause *de novo* bubble formation.

### Vacuum Phenomena and Decompression Sickness

Viscous adhesion and bubble formation are the cause of the cracking sounds which occur in joints when their articular surfaces are pulled apart (Roston and Haines, 1947; Unsworth *et al.*, 1971). The cracking is the collapse of vapor-filled bubbles. These bubbles can persist and expand, however, if a joint is put in traction. The expanded bubbles are known as "vacuum phenomena" and are readily detected by x-ray and CT-scan.

Vacuum phenomena are found in the fingers, wrists, elbows, shoulders, spine, sacroiliac joint, *illium*, *symphis pubis*, hips, and knees (Vann, 1989). Figure 4 is a typical vacuum phenomenon in the hip in a one year old girl (Fuiks and Grayson, 1950). A spontaneous vacuum phenomenon, visible without traction, is present on the left. On the right, the volume of the void increases when traction is applied.

Vacuum phenomena of the spine are found within disks, facet joints, vertebrae, and the spinal canal itself. Figure 5 is a CT-scan of a 52 year old man with chronic back pain and gas in the spinal canal



(Austin *et al.*, 1981). Spinal vacuum phenomena are diagnostic of degeneration and become more common with advancing age (Knutsson, 1942). The increase in vacuum phenomena with age may be related to the increase in DCS risk which occurs with age (Gray, 1951).

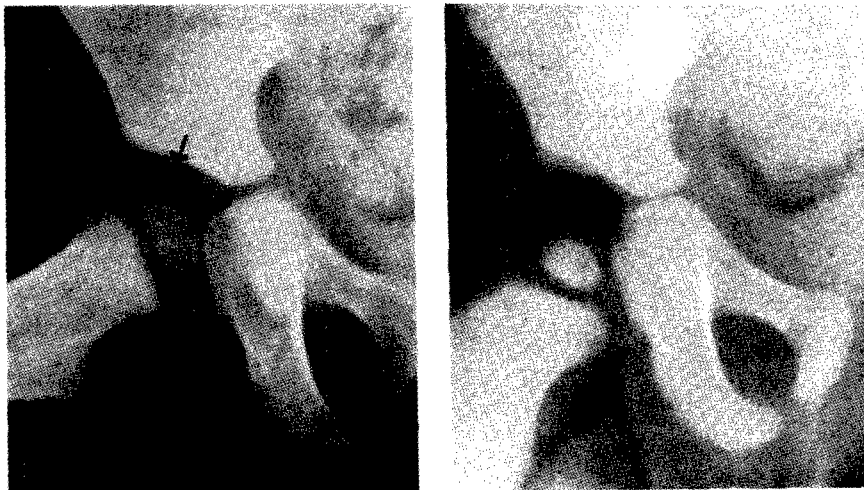

Figure 4. (a) A spontaneous vacuum phenomenon in the hip joint of a 1 year old girl (Fuiks and Grayson, 1950). (b) The vacuum phenomenon expands when the right leg is placed in traction.

Figure 5. Gas within the spinal canal at the L3 level (Austin *et al.*, 1981).



The response of vacuum phenomena to decompression is suggested in Fig. 6. On the left, vacuum phenomena were produced by traction of the wrist (Yousefzadeh, 1979) while, on the right, similar voids were found after decompression to altitude (Thomas and Williams, 1945). It is proposed that viscous adhesion at the interfaces of moving tissues generates both vacuum phenomena and the gas nuclei which grow into the bubbles that cause DCS. Whether or not pain occurs will depend on the location of the bubble and its size. As Webb *et al.* (1944) and Thomas and Williams (1944) pointed out, bubbles in the joint spaces were asymptomatic while ribbons or sheets of periarticular gas (Fig. 2), probably along tendons and fascial planes, were highly correlated with pain.

The existence of vacuum phenomena demonstrates that bubbles are routinely present in humans at sea level. If the viscous adhesion that generates vacuum phenomena also produces the gas nuclei which cause DCS, then increased motion during exercise might be expected to generate more nuclei and greater DCS risk. Exercise before decompression is associated with increased bubble formation in controlled animal studies (Evans and Walder, 1969; McDonough and Hemmingsen, 1984) while anecdotal reports

link weight lifting and long distance bicycle racing with increased DCS risk in humans (Vann, 1982; Nishi *et. al.*, 1982).

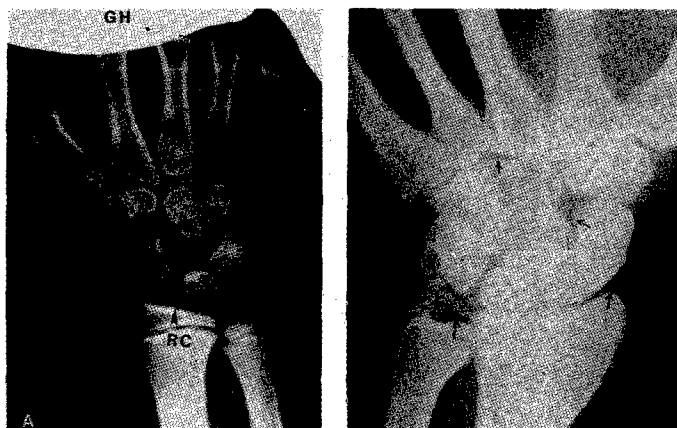

Figure 6. (a) Vacuum phenomena of the wrist produced by traction (Yousefzadeh, 1979). (b) Gas voids in the wrist produced by altitude decompression (Thomas and Williams, 1945).

#### Where Do Bubbles Form?

Bubbles are so common in the blood during decompression that it seems reasonable to assume they form there. This assumption was first tested experimentally in 1774 by Erasmus Darwin (Darwin, 1774). Experiments with blood are difficult because it is so easily contaminated with air during handling. Darwin avoided this problem by isolating a blood-filled section of vessel between sutures before removal from an animal.

We repeated Darwin's studies using isolated inferior *vena cavae* removed from freshly sacrificed rats, rabbits, and dogs (Okang and Vann, 1989). When immersed in saline and decompressed to an altitude of 60-75,000 feet, no bubbles formed in the isolated blood. This is contrary to the appearance of venous bubbles in humans and animals at altitudes above 12,000 feet (Dixon, 1985) and after saturation dives from as shallow as 12 fsw (Eckenhoff, 1991).

If bubbles form extravascularly as a result of viscous adhesion, how do they reach the venous blood where they are commonly found? A bubble expanding in tissue might rupture a capillary and seed the venous circulation with a stream of bubbles, much as happens in a glass of beer. The best evidence linking bubbles in tissue, vascular disruption, and venous bubbles is from Lambertsen's studies of cutaneous counterdiffusion in which isobaric supersaturation of pigs led to bubble formation, subcutaneous bruising, and large volumes of venous gas emboli (Lambertsen, 1989).

Bubbles do not seem to form in all tissues, however. Powell and Spencer (1981) used implanted arterial and venous Doppler probes to study bubble formation in the kidney and brain of rapidly decompressed sheep. Bubbles were not observed in the venous blood of these organs unless arterial bubbles were detected first. If bubbles originate extravascularly, arterial bubbles would not occur unless venous bubbles were arterIALIZED through the heart or lungs.

### The Oxygen Window

Inert gas exchange and bubble growth are strongly influenced by the metabolic consumption of oxygen. The conversion of oxygen into carbon dioxide reduces the tissue oxygen tension to below its level in the lungs, but the CO<sub>2</sub> tension rises only slightly because CO<sub>2</sub> is some 20 times more soluble than oxygen. This is illustrated in Fig. 7a where the bar on the left represents gases in a diver's lungs at sea level. Dalton's law of partial pressures requires that the sum of these gases be 1 ATA. The bar on the right shows the gases in the diver's tissues. Their sum is less than 1 ATA because oxygen is converted into carbon dioxide.

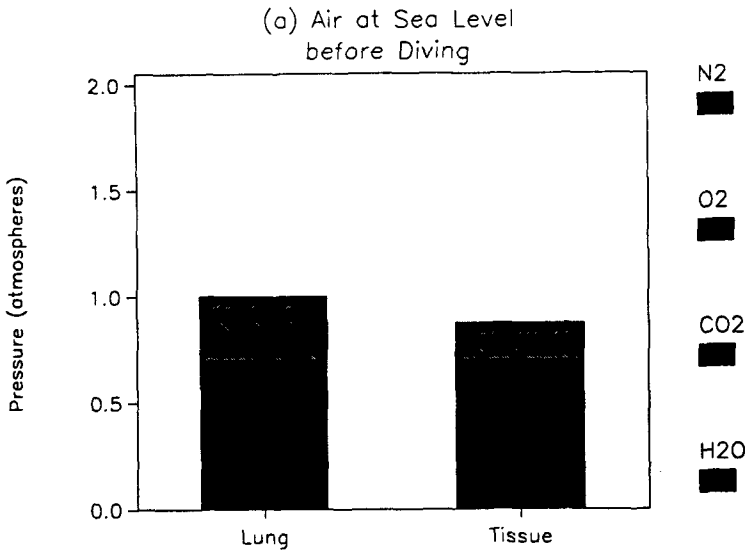
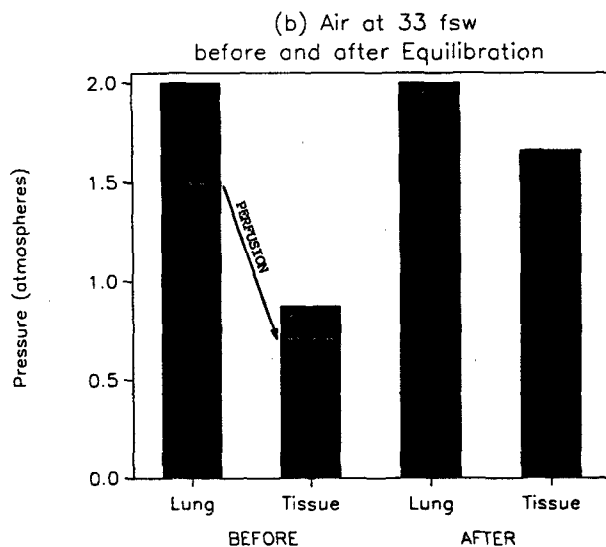

Figure 7a. Gases in the lungs and tissues of an air breathing diver at sea level. The metabolic exchange of oxygen for carbon dioxide results in a total tissue gas tension which is less than the ambient pressure. This difference is the oxygen window.

Now, the diver breathes air at 33 fsw. In Fig. 7b, the bars on the left show the gases in his lungs and tissue upon arrival at depth. The oxygen and nitrogen partial pressures in his lungs have increased to make the sum of all gases equal to the absolute pressure of 2 ATA, but his tissues have absorbed no additional nitrogen. The bars on the right show the lungs and tissues after nitrogen equilibration. The tissue nitrogen tension now equals the alveolar nitrogen partial pressure.

Figure 7b. Gases in the lungs and tissues of an air breathing diver at 33 fsw. Initially, the tissue nitrogen tension is the same as in Fig. 7a, but after sufficient time at depth, tissue nitrogen equilibrates with the 2 ATA of air in the lung.



Upon returning to sea level, bubbles form in the diver's tissues (Fig. 7c). By Dalton's law, the sum of the partial pressures in the bubble is 1 ATA. The water vapor pressure is constant and the oxygen and carbon dioxide partial pressures are controlled to tissue levels. Since the nitrogen tension in tissue is elevated, nitrogen diffuses both into the bubble and into the blood. Nitrogen diffusing into the blood and remaining dissolved is carried to the lungs and eliminated harmlessly, but nitrogen diffusing into the bubble causes it to expand. This is the basis for the bubble models described by Gernhardt (1991) and Gerth *et al.* (1991). Bubble growth by diffusion can be a slow process which delays the onset of DCS symptoms and the appearance of precordial bubbles. It is probably slow bubble growth which makes surface decompression possible.

**Figure 7c. Bubble formation and growth after decompression from 33 fsw to sea level. The bubble grows by inward diffusion of supersaturated nitrogen from tissue. Dissolved nitrogen also is carried to the lungs by the circulation.**

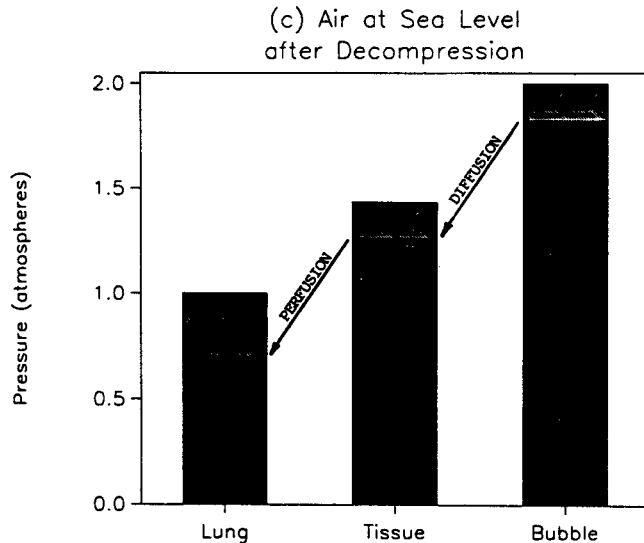

Diffusion slows bubble resolution as well as bubble growth. Note that gas in a bubble must diffuse back into tissue before it can be carried to the lungs by the circulation (Fig. 7c). Thus, the effective halftime for the elimination of gas in a bubble is greater than for the elimination of dissolved gas. In repetitive diving, this might lead to an accumulation of inert gas not expected by a Haldane decompression model which assumes gas to remain dissolved.

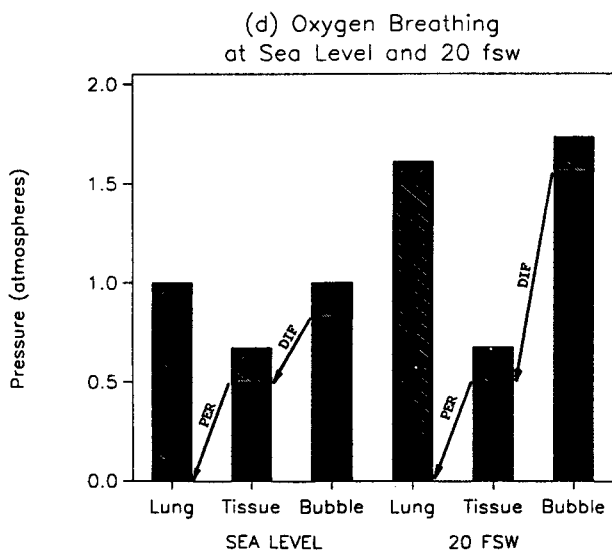

**Figure 7d. Oxygen breathing at sea level and 20 fsw. Oxygen at sea level increases the nitrogen gradient between the lungs and tissue. Oxygen at 20 fsw increases the nitrogen gradient between the bubble and tissue. The oxygen window is the gradient between nitrogen in the bubble and tissue. The oxygen window increases as the nitrogen is eliminated from tissue by perfusion.**

Figure 7d shows that nitrogen elimination is accelerated by breathing 100% oxygen. Oxygen increases the nitrogen gradient between lungs and tissue which makes perfusion more efficient in removing dissolved nitrogen. The reduced tissue nitrogen tension also increases the gradient for the diffusion of nitrogen from the bubble back into tissue.

Two uses of oxygen for diving are illustrated in Fig. 7d. On the right, the diver breathes oxygen at sea level. For repetitive diving, this operationally simple and safe procedure has the potential benefit of reducing surface intervals and increasing repetitive dive times (Fawcett *et al.*, 1991). On the left, the diver breathes oxygen during a shallow decompression stop (Fife *et al.*, 1991). While tissue nitrogen elimination is no different for oxygen breathing on the surface or during decompression, the diffusion gradient for eliminating a bubble is significantly enhanced when oxygen is breathed during decompression (Fig. 7d). The gradient between nitrogen in the bubble and in tissue is known as the  $\Delta$ oxygen window<sup>^</sup>.

### Nitrogen Exchange between Bubbles and Tissue

As diffusion and perfusion are in series when a bubble is present (Fig. 7d), nitrogen in a bubble must diffuse back into tissue before it can be removed by blood flow. Figure 8 shows simulations of the concentration gradients of oxygen, helium, and nitrogen around a dissolving bubble (Van Liew, 1968). Oxygen has the steepest gradient because it is consumed metabolically. The helium and nitrogen gradients extend further into tissue because they are eliminated only by perfusion. Nitrogen has a steeper gradient than helium because nitrogen is less diffusible than helium. A first-order simulation of these gradients uses a bubble which is surrounded by a diffusion barrier (Fig. 9). This simulation is discussed by Gernhardt (1991) and Gerth *et al.* (1991) and was used to calculate the decompression procedures discussed by Fife *et al.* (1991) and Fawcett *et al.* (1991).

Figure 8. Dissolved gas concentration gradients around a bubble filled with oxygen, nitrogen, or helium. The oxygen concentration gradient is steepest because oxygen is metabolized in tissue as it diffuses out of the bubble. Nitrogen and helium are metabolically inert and are removed from tissue only by perfusion. Helium extends further into tissue than nitrogen because it diffuses more quickly (Van Liew, 1968).

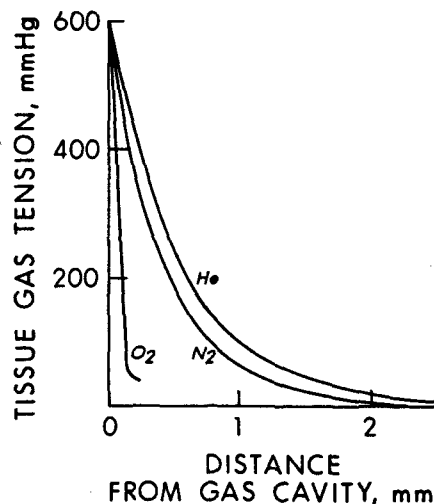

### Nitrogen Exchange between Blood and Tissue

Diffusion gradients disappear several millimeters away from a bubble (Fig. 8), and the diffusion distances between capillaries are so short in most tissues that the intercapillary domains are essentially well-stirred (Homer and Weathersby, 1986). Nitrogen exchange in these domains can be considered to be perfusion-limited as in a Haldane tissue compartment. Indeed, gases diffuse so rapidly

that they can diffuse directly between adjacent arterial and venous vessels (Novotny *et al.*, 1990). Arteriovenous shunting in this manner allows nitrogen to by-pass a tissue in which the intercapillary domains are otherwise perfusion-limited. Nitrogen exchange in such a tissue would be slower than expected on basis of perfusion alone. This may partially explain the long nitrogen exchange halftimes required by decompression models.

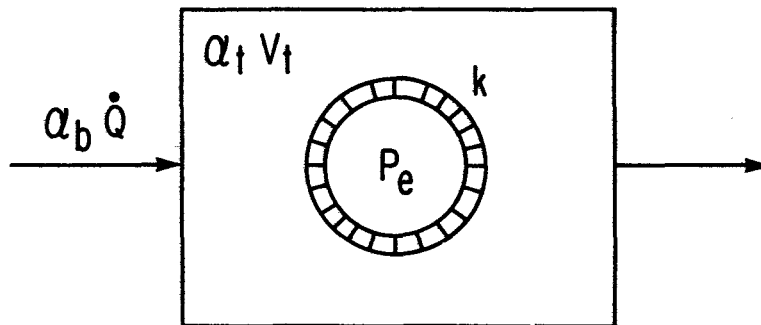

Figure 9. A diffusion barrier surrounding a bubble in a well-stirred tissue provides a first-order simulation of the inert gas gradients in Fig. 8.

#### Literature Cited

- Austin, R.M., M.S. Bankoff, and B.L. Carter. 1981. Gas collections in the spinal canal on computed tomography. *J. Comp. Asst. Tomog.* 5(4): 522-524.
- Bert, P. 1877. Barometric pressure. *Researches in experimental physiology.* Undersea Med. Soc., Bethesda, Md.
- Campbell, J. 1968. The tribonucleation of bubbles. *Brit. J. Appl. Phys. (J. Phys. D)*, Ser. 2, 1: 1085-1088.
- Daniels, S., K.C. Eastaugh, W.D.M. Paton, and E.B. Smith. 1984. Micronuclei and bubble formation: a quantitative study using the common shrimp, *Crangon crangon*. In: *Underwater Physiol.* VIII, pp. 147-157, Ed. A.J. Bachrach and M.M. Matzen, Undersea Med. Soc., Bethesda.
- Darwin, E. 1774. Experiments on animal fluids in the exhausted receiver. *Philos. Trans.* 64: 344-349.
- Derry, T.K. and T.I. Williams. 1960. *A short history of technology.* Oxford University Press.
- Dixon, G.A. 1985. Evaluation of 9.5 psia as a suit pressure for prolonged extravehicular activity. In: *Proc. 23rd Annual SAFE (Survival and Flight Equipment) Symposium.* Dec. 1-5, Las Vegas.
- Dixon, J.P. 1991. Death from altitude decompression sickness: major pathophysiological factors. In: Pilmanis, A.A. (ed.), *The proceedings of the 1990 hypobaric decompression sickness workshop.* USAF Armstrong Laboratory Special Report. In preparation.
- Dowson, D., A. Unsworth, and V. Wright. 1971. The cracking of human joints - a study of 'cavitation' in the metacarpo-phalangeal joint. In: *Proc. Tribology Convention 1971.* Tribology Group, Douglas, Isle of Man, Engl. May 12-15, 1971. *Instn. of Mech. Engrs., London.* Pp. 120-127.

- Eckenhoff, R.G. 1992. Decompression induced bubble formation in humans after shallow saturation dives. *In: Lang, M.A. and R.D. Vann (Eds.). Proceedings of AAUS Repetitive Diving Workshop. Duke University, March 1991. AAUS, Costa Mesa, CA. pp. 219 - 226.*
- Evans, A. and D.N. Walder. 1969. Significance of gas micronuclei in the aetiology of decompression sickness. *Nature, Lond. 222: 251-252.*
- Fawcett, T.A., R.D. Vann and W.A. Gerth. 1992. Surface interval oxygen: Rationale and study design. *In: Lang, M.A. and R.D. Vann (Eds.). Proceedings of AAUS Repetitive Diving Workshop. Duke University, March 1991. AAUS, Costa Mesa, CA. pp. 293-298.*
- Ferris, E.B. and G.L. Engle. 1951. The clinical nature of high altitude decompression sickness. *In: Decompression sickness. Ed. J.F. Fulton. Pp. 4-52. Philadelphia: Saunders.*
- Fife, C.E., G.W. Pollard, G.Y. Mebane, A.E. Boso and R.D. Vann. 1992. A database of open water, compressed air, multi-day repetitive dives to depths between 100 and 190 fsw. *In: Lang, M.A. and R.D. Vann (Eds.). Proceedings of AAUS Repetitive Diving Workshop. Duke University, March 1991. AAUS, Costa Mesa, CA. pp. 45 - 54.*
- Finkelstein, Y. and A. Tamir. 1985. Formation of gas bubbles in supersaturated solutions of gases in water. *AIChE J. 31(9): 1409-1418.*
- Floberg, L. 1964. Cavitation in lubricating oil films. *In: Davies, R., ed. Cavitation in real liquids. New York: Elsevier, pp. 138-146.*
- Francis, T.J.R. 1990. The pathophysiology of decompression sickness. *In: Diving Accident Management. 41st Undersea and Hyperbaric Medical Society Workshop. UHMS Pub. No. 78(DUVACC)12/1/90. Pp. 38-56.*
- Francis, T.J.R., G.H. Pezeshkpour, and A.J. Dutka. 1989. Arterial gas embolism as a pathophysiologic mechanism for spinal decompression sickness. *Undersea Biomed. Res. 16(6): 439-451.*
- Fuiks, D.M. and C.E. Grayson. 1950. Vacuum pneumarthrography and the spontaneous occurrence of gas in the joint spaces. *J. Bone & Joint Surgery 32A(4): 933-938.*
- Gait, D., K.W. Miller, W.D.M. Paton, E.B. Smith, and B. Welch. 1975. The redistribution of vascular bubbles in multiple dives. *Undersea Biomed. Res. 2(1): 42-50.*
- Gerth, W.A. and E.A. Hemmingsen. 1976. Gas supersaturation thresholds for spontaneous cavitation in water with gas equilibration pressures up to 570 atm. *Z. Naturforsch. 31a: 1711-1716.*
- Gerth, W.A., D.G. Southerland, and R.D. Vann. 1992. Quasi-physiological decompression sickness incidence modeling. *In: Lang, M.A. and R.D. Vann (Eds.). Proceedings of AAUS Repetitive Diving Workshop. Duke University, March 1991. AAUS, Costa Mesa, CA. pp. 253 - 262.*
- Gernhardt, M.L., C.J. Lambertsen, R.G. Miller, E. Hopkin and K. Guveyian. 1992. Design of multi-depth decompression tables using a model of tissue gas bubble dynamics. *In: Lang, M.A. and R.D. Vann (Eds.). Proceedings of AAUS Repetitive Diving Workshop. Duke University, March 1991. AAUS, Costa Mesa, CA. pp. 243 - 252.*
- Gray, J.S. 1951. Constitutional factors affecting susceptibility to decompression sickness. *In: Decompression sickness. Ed. J.F. Fulton. Saunders. Philadelphia. Pp. 182-191.*

- Hallenbeck, J.M. and J.C. Andersen. 1982. Pathogenesis of the decompression disorders. *In: The physiology and medicine of diving.* 3rd ed. Eds. P.B. Bennett and D.H. Elliott. Bailliere Tindall, London. Pp. 435-460.
- Harvey, E.N., D.K. Barnes, W.D. McElroy, A.H. Whiteley, D.C. Pease, and K.W. Cooper. 1944. Bubble formation in animals. I. Physical factors. *J. Cellular Comp. Physiol.* 24(1):1-22.
- Hills, B.A. 1971. Decompression sickness: a fundamental study of "surface excursion" diving and the selection of limb bends versus C.N.S. symptoms. *Aerosp. Med.* 42(8): 833-836.
- Homer, L.D. and P.K. Weathersby. 1986. How well mixed is inert gas in tissues? *J. Appl. Physiol.* 60(6):2079-2088.
- Johnson, B.D. and R.C. Cooke. 1981. Generation of stabilized microbubbles in seawater. *Science* 213: 209-211.
- Knutsson, F. 1942. The vacuum phenomenon in the intervertebral discs. *Acta Radiologica* 23: 173-179.
- Lambertsen, C.J. 1989. Relations of isobaric gas counterdiffusion and decompression gas lesion diseases. *In: The physiological basis of decompression.* Proc. of the 38th Undersea and Hyperbaric Medical Society Workshop. Ed. R.D. Vann. UHMS Pub. 75(Phys)6/1/89. Pp. 87-106.
- McDonough, P.M. and E.V. Hemmingsen. 1984. Bubble formation in crabs induced by limb motions after decompression. *J. Appl. Physiol.: Respirat. Environ. Exercise Physiol.* 57(1): 117-122.
- Moon, R.E., Camporesi, E.M., and Kisslo, J.A. 1989. Patent foramen ovale and decompression sickness in divers. *Lancet* 1: 513-514.
- Moon, R.E., J.A. Kisslo, E.W. Massey, T.A. Fawcett, and D.R. Theil. 1991. Patent foramen ovale (PFO) and decompression illness. *Undersea Biomed. Res.* 18(Suppl.): Abstract 1.
- Neuman, T.S., D.A. Hall, and P.G. Linaweaver. 1976. Gas phase separation during decompression in man: ultrasound monitoring. *Undersea Biomed. Res.* 3: 121-130.
- Neuman, T.S. and A.A. Bove. 1990. Combined arterial gas embolism and decompression sickness following no-stop dives. *Undersea Biomed. Res.* 17(5): 429-436.
- Nishi, R.Y., B.C. Eatock, I.P. Buckingham, and B.A. Ridgewell. 1982. Assessment of decompression profiles by ultrasonic monitoring. Phase III: no-decompression diving. DCIEM Report No. 82-R-38.
- Novotny, J.A., D.L. Mayers, Y.-F. J. Parsons, S.S. Survanshi, P.K. Weathersby, and L.D. Homer. 1990. Xenon kinetics in muscle are not explained by a model of parallel perfusion-limited compartments. *J. Appl. Physiol.* 68(3): 876-890.
- Okang, G.I. and R.D. Vann. 1989. Bubble formation in blood and urine. *In: The physiological basis of decompression.* Proc. of the 38th Undersea and Hyperbaric Medical Society Workshop. UHMS Pub. 75(Phys)6/1/89. Pp. 177-178.
- Pilmanis, A.A. 1990a. Ascent and silent bubbles. *In: Biomechanics of safe ascents workshop.* M.A. Lang and G.H. Egstrom (Eds.). AAUS, Costa Mesa. AAUSDSP-BSA-01-90. Pp. 65-71.
- Pilmanis, A.A. 1990b. Personal communication.
- Powell, M.R. and M.P. Spencer. 1981. The pathophysiology of decompression sickness and the effects of Doppler detectable bubbles. Technical Report on ONR Contract N00014-73-C-0094.



- Powell, M.R., M.P. Spencer, and O.T. von Ramm. 1982. Ultrasonic surveillance of decompression. *In: The physiology of diving and compressed air work, 3rd edn., pp. 404-434.* (Ed.) P.B. Bennett and D.H. Elliott. London: Bailliere Tindall.
- Roston, J.B. and R.W. Haines. 1947. Cracking in the metacarpo-phalangeal joint. *J. Anat.* 81:165-173.
- Smith, K.H. 1976. Decompression studies with ultrasound. *In: Decompression procedures for depths in excess of 400 feet.* R.W. Hamilton, Jr., (ed.). 9th Undersea Medical Society Workshop. UMS Report No. WS: 2-28-76. Pp. 229-236.
- Smith, K.H. and L. Stayton. 1978. Hyperbaric decompression by means of bubble detection. ONR Report N0001469-C-0402.
- Strasberg, M. 1959. Onset of ultrasonic cavitation in tap water. *J. Acoustic Soc. Am.* 31(2): 163-176.
- Sykes, J.J.W. and L.J. Yaffe. 1985. Light and electron microscope alterations in spinal cord myelin sheaths after decompression sickness. *Undersea Biomed. Res.* 12(3): 251-258.
- Thomas, S. and O.L. Williams. 1944. High altitude joint pains: their radiographic aspects. U.S. NRC, C.A.M. Report No. 395.
- Thomas, S.F. and O.L. Williams. 1945. High altitude joint pains (bends): their roentgenographic aspects. *Radiology* 44: 259-261.
- Unsworth, A., Dowson, and V. Wright. 1971. "Cracking joints," a bioengineering study of cavitation in the metacarpophalangeal joint. *Ann. Rheum. Dis.* 30: 348-357.
- Van Liew, H.D. 1968. Coupling of diffusion and perfusion in gas exit from subcutaneous pockets in rats. *Am. J. Physiol.* 214: 1176-1185.
- Vann, R.D., J. Grimstad, and C.H. Nielsen. 1980. Evidence for gas nuclei in decompressed rats. *Undersea Biomed. Res.* 7(2): 107-112.
- Vann, R.D. 1982. MK XV UBA Decompression trials at Duke: A summary report. F.G. Hall Lab Report.
- Vann, R.D. 1989. Vacuum phenomena: an annotated bibliography. *In: The physiological basis of decompression.* Proc. of the 38th Undersea and Hyperbaric Medical Society Workshop. Ed. R.D. Vann. UHMS Pub. 75(Phys)6/1/89. Pp. 179-195.
- Walder, D.N. 1966. Adaptation to decompression sickness in caisson work. *In: Proc. 3rd Int. Biometerology Congress, Oxford, pp.350-359.*
- Walder, D.N. and A. Evans. 1974. *In vivo* nuclear fission in the aetiology of decompression sickness. *Nature* 252(5485): 696-697.
- Webb, J.P. *et al.* 1944. Radiographic studies of the knee during bends. U.S. NRC, C.A.M. Report No. 305.
- Wilmshurst, P.T., J.C. Byrne, and M.M. Webb-Peploe. 1990. Relation between interatrial shunts and decompression sickness in divers. *Undersea Biomed. Res.* 17(Suppl.): Abstract 88.
- Yount, D.E. 1982. On the evolution, generation, and regeneration of gas cavitation nuclei. *J. Acoust. Soc. Am.* 71: 1473-1481.
- Yousefzadeh, D.K. 1979. The value of traction during roentgenography of the wrist and metacarpophalangeal joints. *Skel. Radiol.* 4:29-33.

## DIVE PROFILES AND ADAPTATION: PRESSURE PROFILES TARGET SPECIFIC TISSUES FOR DECOMPRESSION INJURY

Charles E. Lehner

Department of Preventive Medicine, Medical School  
University of Wisconsin-Madison  
Madison, WISCONSIN 53705 U.S.A.

*Repetitive diving with compressed air can involve decompression injury as can single dives. Dive profiles target specific tissues for potential decompression injury, with a high proportion of spinal cord decompression sickness (DCS) occurring after short, deep dives, and a high proportion of limb bends, dysbaric osteonecrosis (DON), and chokes after prolonged dives. Repetitive diving can involve spinal cord DCS, possibly caused by the growth of latent bubbles remaining in the spinal cord from previous dives. The conventional Haldanian rates of inert gas washout assumed for tissues vulnerable to decompression injury may be too fast. Countercurrent gas exchange and bubble formation and growth may slow inert gas washouts in the target tissues of decompression injury. A bubble-induced compartment syndrome may be an important pathophysiological mechanism in limb bends, spinal cord DCS, and DON. The development of a compartment syndrome and its high tissue pressure and ischemia in many forms of decompression injury is likely promoted by anatomical compartments, tissue composition high in fat or lipids, complex vascular architecture with countercurrent gas exchange, and bubble formation and growth. Risk associated with repetitive diving may be lowered by the phenomenon of adaptation, the increased tolerance of an individual to decompression with successive hyperbaric exposures.*

### Introduction

Injury from decompression in diving can involve various tissues which respond differently to specific pressure profiles that promote bubble formation in tissues. Dive profiles, including repetitive dives, target specific tissues for potential decompression injury, with bone necrosis and various forms of decompression sickness (DCS) being possible outcomes. Repetitive diving may also involve adaptation, the phenomenon of decreased susceptibility to symptomatic injury after successive hyperbaric exposures. This paper describes the physiological and anatomical factors that predispose certain tissues to decompression injury and the role pressure profiles play in controlling the nature of decompression injury.

### Decompression Injury

The major forms of decompression injury are bone necrosis and DCS. The aseptic bone necrosis that develops from hyperbaric exposure is usually referred to as dysbaric osteonecrosis (DON) but sometimes as hyperbaric osteonecrosis. Extensive reviews of DON appear in reports by McCallum *et al.* (1982) and Davidson (1976, 1989). Nevertheless, the factors that initiate the development of DON remain uncertain and controversial (Walder, 1990). The major forms of DCS include limb bends, spinal cord DCS, and chokes, a respiratory form of DCS caused by pulmonary emboli (Atkins *et al.*, 1988).

## Historical Perspective

Two early reports concerning DCS by Haldane and his associates (Haldane *et al.*, 1907; Boycott *et al.*, 1908) and a review of DCS by Behnke (1945) showed extraordinary insight and set the stage for many later developments in diving physiology. Decompression studies at the University of Wisconsin investigated dive profile control of DCS and DON (Lanphier *et al.*, 1984; Lehner *et al.*, 1985; Lehner and Lanphier, 1989). Much of our understanding is the result of unexpected experimental outcomes involving sheep and pygmy goats.

### Haldane and co-workers: Physiological scaling and dive profiles

Haldane's 1907 committee report to the British Admiralty on methods to improve diving to 30 fathoms initiated an extraordinarily productive era of diving physiology research in the United Kingdom. The 1907 report detailed the research findings and theoretical basis for recommendations to improve efficiency and safety in diving. A later paper appeared in the *Journal of Hygiene* (Boycott *et al.*, 1908). Their decompression research involved both animal and human studies.

Decompression research with animals initially included mice, rats, guinea pigs, rabbits and goats as experimental subjects. These experiments suggested the important principle of physiological scaling by body weight or mass known as allometry (Schmidt-Nielsen, 1984). Haldane and co-workers (1907) discovered that small animals escaped decompression injury, while large animals, particularly the goat, were most often affected. In one such experiment described in the report, out of 10 decompressed goats, two died, three were seriously ill, three were slightly ill, and two showed no symptoms. The largest rabbit died, but the four smaller rabbits showed no symptoms. Smaller animals, such as the guinea pigs, rats and mice, remained asymptomatic. Boycott and Damant summarized the animal experiments by reporting (Haldane *et al.*, 1907), "In general it may be stated that the rapidity with which the tissues of the body are brought into relation with the air in the lungs varies inversely with the size of the animal." These experiments established that inert gas washin and washout rates are faster in smaller animals.

In general, large mammals have slower heart rates, a lower metabolism and lower tissue blood flow rates than small mammals (Schmidt-Nielsen, 1984). Inert gas washin and washout rates in tissues are generally faster in smaller animals according to this physiological scaling relationship. Based on this principle, an animal with a body size similar to the human would be similar in its response to hyperbaric exposure and decompression. Haldane's group chose the largest experimental animal available to them, the goat, as a human model in their decompression research and voiced concerns about extrapolation. Extrapolation of decompression responses from small animals to humans involves, "factors of almost qualitative dimensions," wrote Boycott and Damant in the British Admiralty report (Haldane *et al.*, 1907).

Differences in the form of DCS affecting divers and tunnel workers were also apparent to the Haldane group. At the time, it was a common observation that "divers, with short exposures to high pressures, experience severe symptoms or none at all, while caisson workers, with long exposures to lower pressures, suffer very frequently from 'bends' and relatively seldom from paralysis or death," quoting from the Admiralty report. This is the earliest report, known to this author, of pressure profiles influencing the form of DCS provoked. Animal DCS studies and other reports now corroborate our observation that short deep dives, so-called "bounce" dives, provoke spinal cord DCS, and long, relatively shallow dives and tunnel or caisson exposures provoke limb bends (Lanphier *et al.*, 1984; Lehner and Lanphier, 1989).

### Behnke: Limb bends and dysbaric osteonecrosis

During a lecture series on DCS at New York University, Behnke (1945) made remarkably insightful observations about the pathogenesis of DCS and DON. He pointed out the importance of bone as a potential site of limb bends by implicating fatty marrow, with its high absorption coefficient for N<sub>2</sub>, its sluggish sinusoid circulation, and the natural obstructions to the exit of bubbles in the rigid-walled bone

cortex surrounding the marrow. What Behnke described is a compartment containing abundant fatty tissue that can serve as a reservoir of N<sub>2</sub> for bubble formation. The vulnerable long bone, according to Behnke, is the organ that renders man unsuited for long exposures in compressed air.

#### Dive profiles control the form of DCS

Decompression studies at the University of Wisconsin simulated dives with a hyperbaric chamber that also can simulate altitude exposure (Lanphier and Lehner, 1990). Early studies begun by Edward Lanphier used sheep and pygmy goats, but we now use only sheep as the large animal model for human DCS and DON studies because of disease and availability problems with pygmy goats.

Our early decompression experiments involved hyperbaric exposures of sheep and pygmy goats, often followed by a brief altitude excursion, simulating 8000 ft pressure (570 torr), to provoke DCS. The profiles explored a wide range of simulated dive durations, with 24, 4, and 1/2-hour hyperbaric exposures and conventional no-stop decompressions (Lehner *et al.*, 1985; Lanphier and Lehner, 1990). Careful observation for potential DCS signs was essential. In these animals, clinical observation of limb lifting indicated limb bends, and labored breathing indicated chokes. Spinal cord DCS frequently presented as transient limb paralysis.

Results from the 24 and 4-hour hyperbaric exposures of sheep and pygmy goats matched our conventional expectations, with about 90% of the cases involving limb bends and about 10% divided between chokes and spinal cord DCS (Fig. 1). The 1/2-hour simulated dives surprised us. With a few 1/2-hour experiments, the number of spinal cord DCS cases exceeded all CNS cases previously observed. Sheep and goats sustained about an order of magnitude more CNS-DCS, overwhelmingly spinal cord DCS cases, after the short, 1/2-h simulated dives than after the longer 4 and 24-hour simulated dives (Lehner *et al.*, 1985). Overall, the total incidence of DCS provoked across the three durations of simulated dives was similar. More than one form of DCS occurred in some of the 405 DCS cases among the 977 animal dives, so total percentages can exceed 100%. Recovery of the sheep and goats between dives was usually at least a week.

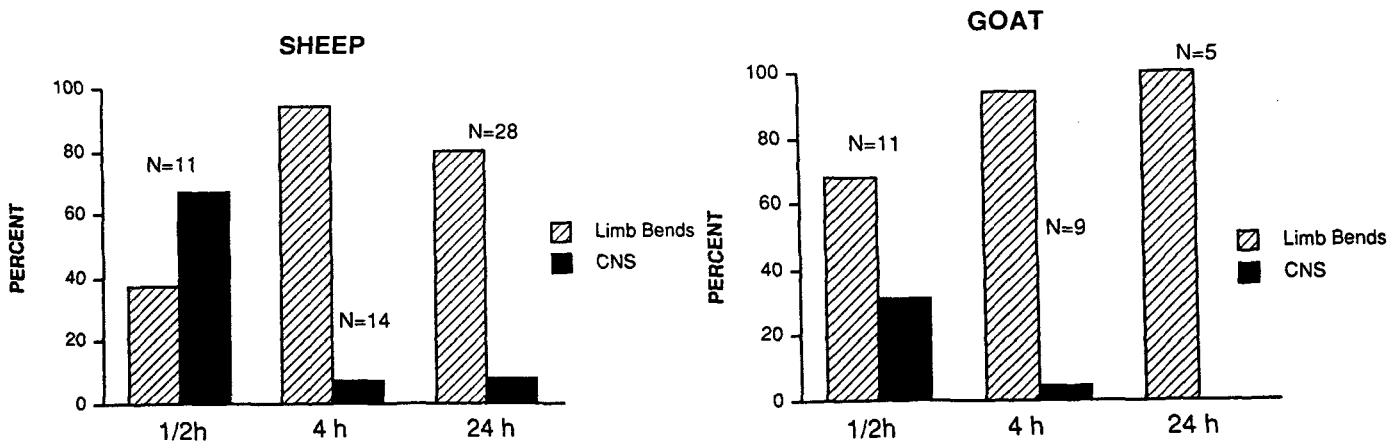

Figure 1a-b. Percentage of DCS manifestations in sheep and pygmy goats after no-stop hyperbaric exposures. The number of sheep and pygmy goats in each simulated dive series is indicated.

Decompression responses of sheep and goats are consistent with the observation made by Haldane and associates about dive profiles influencing the form of DCS (Haldane *et al.*, 1907). The high prevalence of paralysis episodes in divers, interpreted as being mostly from short, deep dives, is confirmed. Likewise, the high prevalence of limb bends in tunnel workers, with hyperbaric exposures

similar to long, relatively shallow dives, is also confirmed. Published reports of a high prevalence of limb bends in tunnel workers who sought recompression treatment and a high prevalence of CNS-DCS in divers, primarily spinal cord DCS, also supports this relationship (Lehner and Lanphier, 1989). When DCS results from compressed air diving, short, deep bounce dives with no-stop decompression produce a high proportion of spinal cord DCS cases, and long, relatively shallow dives produce a high proportion of limb bends cases (Lehner and Lanphier, 1989).

### **Dive Profiles, DCS Manifestations, and Risk**

Rather than considering DCS to be a single entity, we view DCS as decompression injury to a constellation of susceptible tissues. Each target tissue in DCS can respond differently to decompression. Each form of DCS represents at least one site of tissue injury, and each form contributes to the overall cumulative DCS incidence. DCS incidence, as it is usually considered, then represents the cumulative incidence of all major forms of DCS. Each form of DCS and its tissue injury also has its own particular anatomical and physiological characteristics that respond differently to the spectrum of dive profiles, and each form of DCS carries a different level of personal risk to the diver.

What do such risk levels mean to the recreational, scientific and commercial divers? A diver may risk only transient pain in limb bends but faces paralysis and death as possible outcomes in spinal cord DCS. Diving practices should attempt to minimize serious risk by avoiding dive profiles that carry the highest risk of serious injury particularly from spinal cord DCS and chokes (Lehner and Lanphier, 1989).

### **Dysbaric Osteonecrosis: Diver's Bone Necrosis**

In its early history, DON was almost exclusively described as a condition associated with tunnel work under compressed air conditions. DON is a condition associated with prolonged hyperbaric exposure. Usually, early tunnel worker exposures involved 6-8 hour shifts at maximum pressure (Keays, 1909).

As described previously, sheep exposures of 24-hour duration caused some sheep to lift their limbs intermittently for many hours after decompression. X-ray films and bone scans revealed lesions in the long bones of the limb bends affected sheep. DON can be induced in sheep with 24-h hyperbaric exposures at maximum pressures as low as 20 pounds/in<sup>2</sup> (psig) or 2.4 atm abs, equivalent to about 45 feet of sea water pressure. Milder lesions will also appear in sheep exposed for up to 4 hours of increased pressure in simulated air dives. Interestingly, limb bends signs, especially in the 24-h exposures, will often persist as sporadic, mild limb lifting for more than a day. This observation suggests a relationship between limb bends and DON. The discomfort in limb bends may be a manifestation of increased marrow tissue pressure (Behnke, 1945; Nashimoto and Lanphier, 1991).

### **Japanese diving fishermen and dysbaric osteonecrosis**

Japanese diving fishermen who use compressed air collect shellfish, mostly pen shells, for their adductor muscles, a highly prized commodity destined for sushi bars. Studies of those diving fishermen with DCS also report a high prevalence of bone necrosis in the long bones of divers (Amako *et al.*, 1974). Diving fishermen typically conduct long duration dives, often repetitive, with short intervals spent at the surface. As in the decompressed sheep, persistent limb bends frequently occur in those divers afflicted with DON (Hayashi *et al.*, 1978). The DON incidence, in this population of diving fishermen, exceeds 50%.

The danger of the diving practices of Japanese diving fishermen is illustrated in a repetitive dive profile recorded by Yasushi Taya and Yoshihiro Mano in 1990 (Fig. 2). The dive profile includes three closely-spaced dives to somewhat greater than 15 m and a surface decompression made in a pressure chamber aboard the fishing boat. Surface intervals are brief, at 13, 14 and 8 minutes, over a period of approximately 8 hours, an exposure duration similar to tunnel workers exposed to hyperbaric conditions. Hatched areas in the graph represent missed decompression time. These diving practices are associated with a high risk of DON.

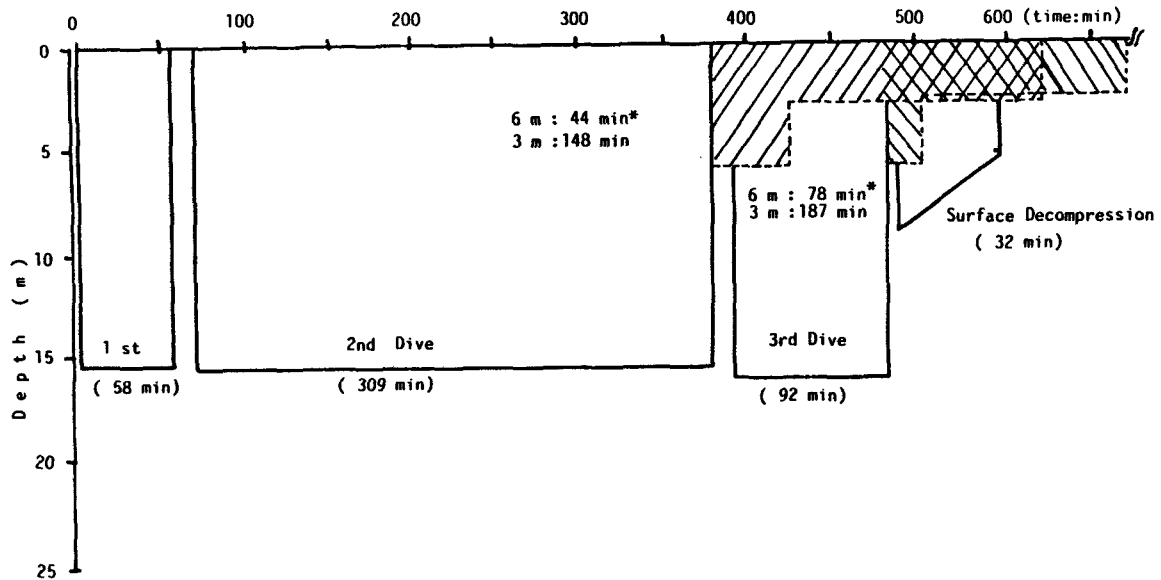

**Figure 2.** A repetitive dive profile recorded from a Tairagi, pen shell, diving fisherman in southern Japan (ADR No.6: T.T.). Three closely-spaced dives and surface decompression are represented in the smoothed pressure profile. "Missed" decompression times, based on U.S. Navy Standard Air Table, are indicated by the hatched areas.

While most recreational divers will never conduct repetitive dives as rigorous as those in the previous example, some divers may unintentionally engage in diving practices that carry a high risk of DON.

### Adaptation, Acclimatization, and Acclimation

Adaptation or acclimatization to hyperbaric exposures is an individual's increased resistance to DCS with successive hyperbaric exposures (Walder, 1966). The conventional terminology used in this connection is adaptation, although such short-term physiological change in physiology is usually referred to as acclimation or acclimatization. Tunnel workers exposed on a daily basis to hyperbaric conditions will within a few days develop an increased tolerance to decompression with fewer cases of symptomatic limb bends (Golding *et al.*, 1960).

Perhaps the best examples of adaptation were reported from the tunnel workers using compressed air, in accounts of the Dartford Tunnel project (Golding *et al.*, 1960) and in a review article by Dennis Walder (1966). Walder described several examples of increased resistance to decompression that illustrate adaptation. In the Dartford Tunnel experience, the number of treated cases of limb bends dropped from approximately 12 to 2% in a population of 120 men during the first 10 hyperbaric

exposures. Physical conditions of the hyperbaric exposures were similar, yet DCS incidence dropped six-fold.

Compelling evidence for the adaptation phenomenon was also demonstrated with the loss in human tolerance to decompression with longer times between exposures due to weekends, holidays and strikes. At the Dartford Tunnel, workers who did not enter hyperbaric conditions for intervals of 2 to 10 days between hyperbaric work showed a loss of adaptation as limb bends cases increased with time since a worker's previous hyperbaric exposure (Golding *et al.*, 1960). Limb bends incidence rose from approximately 2% with a two-day interval to 10% with a ten-day interval of not working in hyperbaric conditions, even though exposure pressure, shift length, and individual workers remained essentially the same.

Another example of adaptation and its loss occurred with the Auckland Bridge project (Walder, 1966). This example illustrates the adaptation phenomenon with successive exposures to compressed air followed by a loss of adaptation resulting from the hiatus of hyperbaric exposures during a workers' strike. Before the strike, exposure pressures increased over time, but the incidence of treated limb bends cases initially rose then eventually declined to 2%. A strike interrupted the daily routine of hyperbaric exposures, and then work resumed. An abrupt increase in the number of treated limb bends cases to approximately 8% indicated the loss of adaptation in the returning workers.

In tunnel workers, a single hyperbaric exposure per day reduces the incidence of DCS. So-called "work-up" dives that involve frequent diving also may confer adaptation. Work-up dives appear to have afforded protection to heliox divers in a sea trial study conducted by David Elliott (1969). Work-up dives consisted of compressed air and heliox dives over a two-week period before the 270 to 300 ft trial, "bounce" dives on heliox, a breathing mixture of helium and oxygen. Generally, DCS cases in heliox trials were in those divers who had not undergone preliminary, work-up dives.

Animal experiments support the observations of adaptation in tunnel workers and divers. While examples of adaptation in humans come from relatively moderate decompressions, animal experiments have emphasized extreme pressure changes, often referred to as "pressure spike" experiments. Pressure spike experiments with transparent shrimp (Evans and Walder, 1969) and rats by Vann *et al.* (1980) demonstrate adaptation by a proposed mechanism of crushing bubble nuclei or microbubbles, the probable sites of bubble formation.

In transparent shrimp, the adaptive effect of a pressure spike was tested by observing the presence or absence of bubbles in shrimp decompressed to a reduced pressure of 0.08 ATA (atmospheres absolute) with or without a pressure spike to 170 ATA preceding the decompression. If tissue gas loading were the sole controlling factor in bubble formation, more bubbles would be expected in those shrimp experiencing even a brief pressure spike, because more dissolved N<sub>2</sub> is expected to be contained within tissues of the pressure "spiked" shrimp. But fewer bubbles formed in the pressure "spiked" shrimp than in shrimp not "spiked." Shrimp subjected to a pressure spike showed adaptation by bubbling less than shrimp not so conditioned before hypobaric decompression.

Pressure spike experiments with rats conducted by Vann and associates (1980) supported the shrimp observations by Evans and Walder. Brief pressure spikes to 19 and 31 ATA immediately preceded 2-hour hyperbaric exposures, at 8.3 ATA, of the "spiked" rats with control rats not experiencing a pressure spike. Contrary to the expectation that more DCS would occur in rats with the greater hyperbaric exposure, rats with the greatest pressure spike had the lowest DCS incidence, 64%, than rats not experiencing a pressure spike, with an 83% DCS incidence. This study and the shrimp bubble findings both suggest a plausible mechanism for adaptation that involves the "crushing" or elimination of microbubbles.

### **Microbubble explanation for adaptation**

Harvey (1944, 1951) demonstrated the importance of clean containers and liquids in the mechanism for bubble formation upon decompression. Extraordinary decompressions are required to cause bubble formation in clean H<sub>2</sub>O in smooth containers. In fact, H<sub>2</sub>O must be decompressed from a pressure of 100 to 1000 ATA for bubbles to form. With gas nuclei, bubbling occurs readily with minimal decompression. The presence or absence of micronuclei can dramatically alter the decompression outcomes of *in vitro* experiments with blood. Blood in contact with air will bubble readily upon decompression, but blood without such contact with air resists bubbling (Harvey, 1951), a finding reconfirmed by Okang and Vann (1989). Harvey also observed that pressure spikes will alter various tissues so they no longer readily bubble. Harvey (1944) stated that gas nuclei are believed to be attached to or form on the walls of blood vessels. Thus, the presence of microbubbles appears to be required for the bubble formation known to occur in animals or humans undergoing modest decompression, as in typical scuba diving.

Micronuclei or microbubbles, with stabilized bubble skins have been extensively investigated by David Yount. As an extension of this research, Yount (1990) has developed the concept of the varying permeability nuclei to formulate decompression tables.

The source of microbubbles responsible for bubble formation in DCS remains uncertain. One proposed source of microbubbles has been ionizing radiation, including the decay of <sup>238</sup>U, a radionuclide that preferentially deposits in bone (Walder and Evans, 1974). Ionizing radiation will cause bubbles to form in a fluid. A much greater source of ionizing radiation occurs with radon gas, which enters the body through the lungs, and its radionuclide daughter products (Harley 1989, NCRPM, 1987). In the lungs, blood is exposed to ionizing radiation from Rn and its daughter products.

Another proposed source of microbubbles involved in DCS is tribonucleation or cavitation, reviewed by Vann *et al.* (1989) and Hemmingsen (1989). Knuckle "popping" is an example of cavitation and bubble formation, as tissue surfaces move past each other and create high negative pressures which form bubbles. Such tribonucleation (Vann *et al.*, 1989) gives rise to bubble formation in fluids momentarily at high negative pressures. In the animal decompression studies conducted by Hemmingsen and associates (1989), bubbles formed in regions where surfaces rubbed each other, such as the articulated spines in the transparent caudal fins of fishes. When tissue surfaces were prevented from moving, few bubbles formed in sites where previously bubbles formed under the same conditions.

Other sources of microbubbles also appear plausible. One potential source is fatty tissues. Such tissues with a high N<sub>2</sub> solubility provide an abundant source of N<sub>2</sub> upon decompression from exposure to compressed air. Fatty and lipid-rich tissues, with hydrophobic surfaces, may become sources of microbubbles upon abrupt decompression.

In principle, human adaptation involves the elimination of microbubbles, gas nuclei, or microcrevices as sites of bubble formation with successive hyperbaric exposures. If sites of bubble formation are lost in the diver who experiences hyperbaric exposures, then the conditioned diver will likely form fewer bubbles than the unconditioned diver who lacks adaptation. However, the relative importance and basis for the adaptation phenomenon remains uncertain and controversial. Questions remain about the comparative importance of adaptation and the microbubble explanation, and this uncertainty is compounded by those instances of an apparent failure of divers to show adaptation with successive hyperbaric exposures (Eckenhoff, 1989).

### **Complement activation explanation for adaptation**

Complement activation of the blood offers a consistent, alternative explanation for the adaptation phenomenon reported in tunnel workers and divers. Recent animal experiments by Ward and his colleagues (1990a) and their review of the topic (1990b) provide evidence for the importance of the complement system in blood plasma in the pathogenesis of DCS.



Individual variation in DCS susceptibility and the adaptation phenomenon both appear to be controlled to some degree by complement activation. If bubbles activate the complement system, then DCS is more likely according to Ward and his associates (1990b). The loss of adaptation, with increased time between hyperbaric exposures, also corresponds to the regeneration of the complement system by the body when bubbles are no longer present in the blood. As a result, the individual again becomes more susceptible to DCS without successive decompressions. In rabbits, both successive hyperbaric exposures and pharmacological decompensation afford protection from DCS in decompression (1990a). The degree of protection from DCS afforded to the human, whose blood has been decompensated, remains unknown.

#### **Adaptation: microbubbles or complement activation?**

Both hypothesized mechanisms for adaptation involve bubble formation. The loss of microbubbles in "acclimatized" humans is hypothesized to lower the incidence of symptomatic DCS, mostly limb bends, in subsequent decompressions. Decompensation of the blood in the presence of circulatory bubbles is also hypothesized to lower the incidence of DCS in subsequent decompressions. However, both proposed mechanisms are confounded, especially by the time course effects that involve gaining microbubbles and regeneration of the original circulating concentrations of the complement system with time. Both mechanisms appear to have validity, but the relative importance of each in controlling DCS is uncertain and remains an important topic for research.

### **Anatomical and Physiological Factors in Decompression Injury**

Only some tissues appear especially vulnerable to decompression injury. In these tissues, some physiological and anatomical factors are similar and may potentiate decompression injury. Tissue sites of limb bends, DON and spinal cord DCS involve anatomical and physiological similarities which appear to make them vulnerable to decompression injury. The sites of decompression injury often represent tissue compartments. The classic compartment syndrome, associated with increased tissue pressure and its ischemic injury, is caused by trauma to muscle enclosed in a *fascia* compartment (Matsen 1975; Mubarak and Hargens, 1981) and appears relevant as an analogous mechanism for those tissue sites vulnerable to decompression injury. The presence of fat or lipids in these tissue sites, whether the long bones or the spinal cord, is another factor, especially with compressed air exposures and the high solubility of N<sub>2</sub> in fat and lipids.

What Behnke (1945) described in the long bone, with its marrow compartment and potential for ischemic injury with blood flow impairment from bubble formation, is essentially the basis for a bone compartment syndrome in the development of dysbaric osteonecrosis.

With decompression, we hypothesize that a series of events in the long bones cause DON, a form of ischemic bone necrosis (Ficat and Arlet, 1980). Bubbles can form in the fatty marrow and may occlude or obstruct blood flow in the long bones. Space occupying bubbles in the marrow may increase pressure within the marrow cavity and adjacent cortical and cancellous bone and cause ischemia. Blood flow in cortical bone is vulnerable to elevated marrow pressure, because the major arteries of the long bones first enter the marrow compartment before they return to the cortical bone and branch into capillary beds. Most venous blood also returns through the marrow compartment in a remarkably convoluted, parallel system of arterial and venous vessels, often with countercurrent blood flow, before it exits the bone (Williams *et al.*, 1984). Dysbaric osteonecrosis presumably occurs in the long bones when bubble-induced ischemia is sufficiently prolonged that the lack of oxygen, intravascular coagulation and hemostasis, or secondary reperfusion injury kills bone and fatty marrow.

Elevated marrow pressure may also be responsible for limb bends (Nashimoto and Lanphier, 1991). Behnke (1945) observed that recompression therapy for limb bends, in the early stages, sometimes causes additional pain. This painful "bone squeeze" may result from the reduction of bubble volume in the marrow compartment under increased pressure during recompression. Nevertheless, a pressure-

sensitive compartment is implicated in limb bends, whether the site of limb bends pain lies in the marrow, or the richly-innervated periosteal sheath surrounding the cortical bone, or somewhere else in the limbs.

The spinal cord represents an anatomical compartment that is also vulnerable to decompression injury. An anatomical compartment, defined by the *dura* (Hills and James, 1982), exists in the spinal cord. Another compartment is formed by the spinal column, which surrounds the spinal cord. The spinal cord contains abundant lipid-rich, myelin sheaths seen as white matter and well-illustrated in Netter's (1989) anatomical monograph. White matter of the cord becomes an abundant source of dissolved  $N_2$  after short, deep bounce dives which provoke a high percentage of spinal cord DCS cases (Lehner and Lanphier, 1989). Blood flow in the spinal cord is characterized by its watershed flow pattern (Batson, 1940; Zülch and Kurth-Schumacher, 1970) which adds to the vulnerability of the cord in decompression injury (Hallenbeck, 1976; Hallenbeck and Andersen, 1982). Fatty tissues, which partially surround the cord, function to cushion the cord. With decompression, these fatty tissues may also become an abundant source of  $N_2$  for bubble formation. Intravascular bubbles, especially with bubbles in the epidural vertebral venous system (Hallenbeck *et al.*, 1975; Palmer, 1986), may obstruct venous blood flow from the spinal cord (Hallenbeck *et al.*, 1975), initiate intravascular coagulation, and cause focal infarctions in the white matter of the spinal cord (Palmer *et al.*, 1976; Palmer *et al.*, 1978). Ischemia in the spinal cord may also potentiate extravascular, autochthonous bubble formation in the cord (Francis *et al.*, 1988; Francis *et al.*, 1990).

Thus, a compartment mechanism may be implicated in dysbaric osteonecrosis, limb bends, and spinal cord DCS. Limb bends discomfort may result from increased tissue pressure in the long bones which contain fatty marrow. DON may be the chronic manifestation of an ischemic decompression injury causing limb bends, as bone death ensues after a prolonged episode of untreated, symptomatic limb bends. Spinal cord DCS may also involve a compartment syndrome, with anatomical compartments, lipid-rich myelin and fatty tissues, and a complex vasculature, all of which lead to the spinal cord's vulnerability to decompression injury.

### Repetitive Diving and Decompression Injury

How may repetitive diving influence decompression injury?  $N_2$  loading of tissues can be cumulative in repetitive diving, particularly in slow tissues, such as fatty marrow and cortical bone. Tissues may not fully complete their tissue  $N_2$  washouts with decompression to surface pressure during short surface intervals.

Vascular architecture can be expected to play an important role in the rate of tissue gas washouts and potential decompression injury. Tissue inert gas washouts may be considerably slower than expected in a Haldanian exponential washout. Countercurrent exchange of inert gas (Homer *et al.*, 1990; Novotny *et al.*, 1990), between parallel but opposing arterial inflow and venous outflow in blood vessels, can extend tissue gas washout times, especially in such anatomically complex tissues as the long bones and spinal cord.

Bubble formation presumably reduces venous outflow in many tissues. Latent, silent bubbles formed after one hyperbaric exposure may become important with successive repetitive dives. Bubble formation and growth may promote ischemia and an elevation of tissue pressure and cause a compartment syndrome in those tissues vulnerable to decompression injury.

Repetitive diving can affect even a fast tissue, such as the spinal cord. Paulev (1965) reported DCS after his series of closely-spaced, repetitive breath-hold dives to 15-20m conducted in a submarine escape training tank. Paulev's surface intervals ranged from a few seconds to 1-2 min. Various symptoms and signs of DCS personally described by Paulev and those in three similar cases are reminiscent of the potentially fatal taravana or "pearl diver disease" of the Tuamotu Archipelago in

the South Pacific. If surface intervals in repetitive breath-hold dives are longer than 3-4 min, e.g. 10 min, the taravana phenomenon among native divers is rare.

In our view, depending upon the intervals between dives, one tissue may be favored over another in  $N_2$  loading such as found with the use of compressed air in scuba diving. A schematic example of Haldanian washin and washout in spinal cord and bone illustrates this principle (Fig. 3). Bone, the "slower" tissue, eventually loads with dissolved  $N_2$ . A compartment syndrome develops with the formation of bubbles accompanying  $N_2$  supersaturation upon decompression. As  $N_2$  washout ceases in the bone, the bone essentially becomes a tissue with an infinite tissue half-time washout.

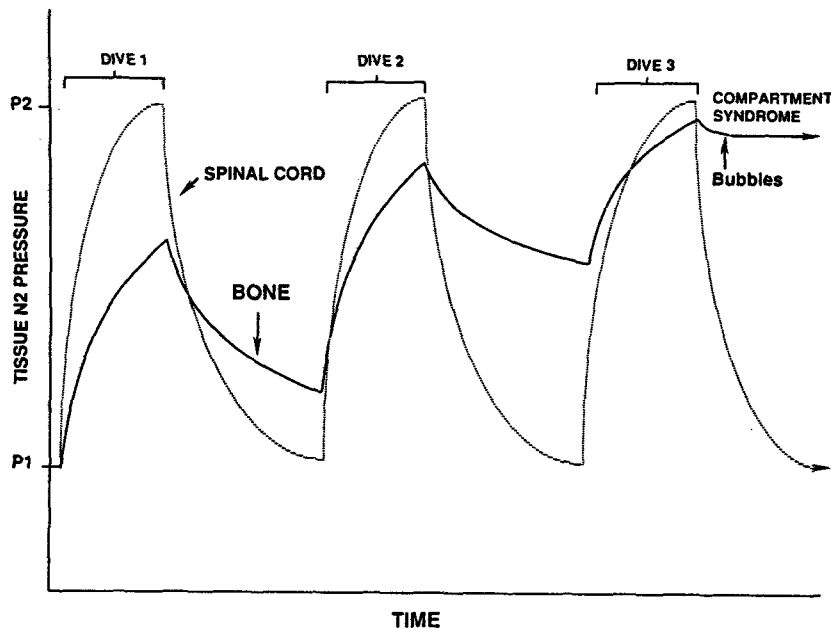

**Figure 3.** Proposed Haldanian washin and washout relationships in bone, a "slow" tissue, and spinal cord, a "fast" tissue. Bone eventually loads with sufficient  $N_2$  that bubbles form upon the third decompression and induce a compartment syndrome which ceases bone  $N_2$  washout. Spinal cord  $N_2$  washouts proceed uneventfully.

Haldanian inert gas washin and washout assumptions are especially useful as a starting point, but tissue washouts appear overly brisk in the Haldane model. Homer, Weathersby and Novotny (1990) have demonstrated the importance of countercurrent exchange in slowing tissue washouts. In addition to countercurrent exchange, bubbles may also form and slow tissue washouts. Bubble formation and growth may cause a compartment syndrome that ceases blood flow to the tissue, and the tissue's inert gas washout essentially ceases (Fig. 4). Prompt recompression treatment can reduce the size of the bubbles and initiate resumption of the inert gas washout process.

Initially silent, asymptomatic bubbles may be important in the development of decompression injury in repetitive scuba diving. In a schematic illustration (Fig. 5), gas bubbles, mostly  $N_2$ , form in a tissue upon decompression. Tissue perfusion decreases as tissue bubbles grow upon decompression and increase tissue pressure so that tissue pressure approaches arteriolar pressure in the tissue. Tissue perfusion then increases as the second dive goes to maximum depth and a tissue's bubbles decrease in size. Additional dissolved  $N_2$  washes into the tissue. Upon the second decompression, bubbles already present, which survived recompression in the second dive, again enlarge to cause a compartment syndrome, with a high tissue pressure and no tissue blood flow. The relatively high percentage of spinal cord DCS cases after repetitive diving reported by the Divers Alert Network (1991) may reflect

the importance of latent bubbles slowing tissue washouts and increasing the risk of decompression injury to the spinal cord.

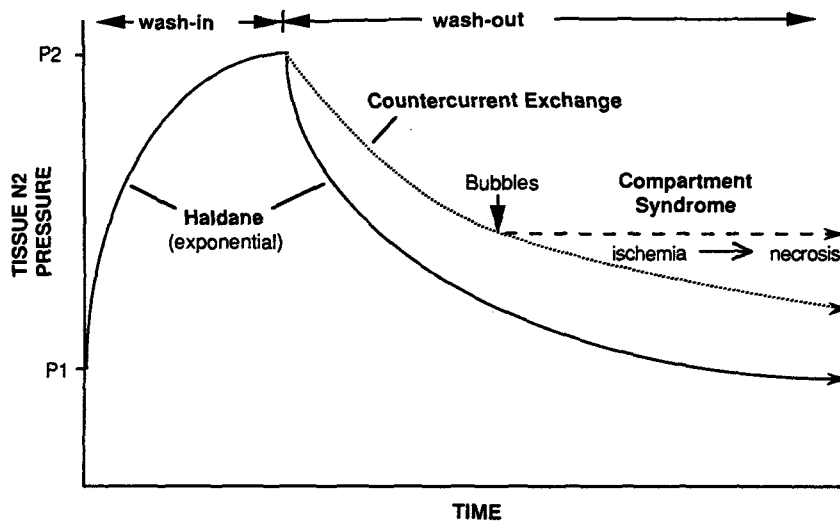

Figure 4. Various mechanisms which may slow tissue N<sub>2</sub> washouts from a Haldanian exponential. These mechanisms include countercurrent exchange and a bubble-induced compartment syndrome which involves tissue ischemia and necrosis.

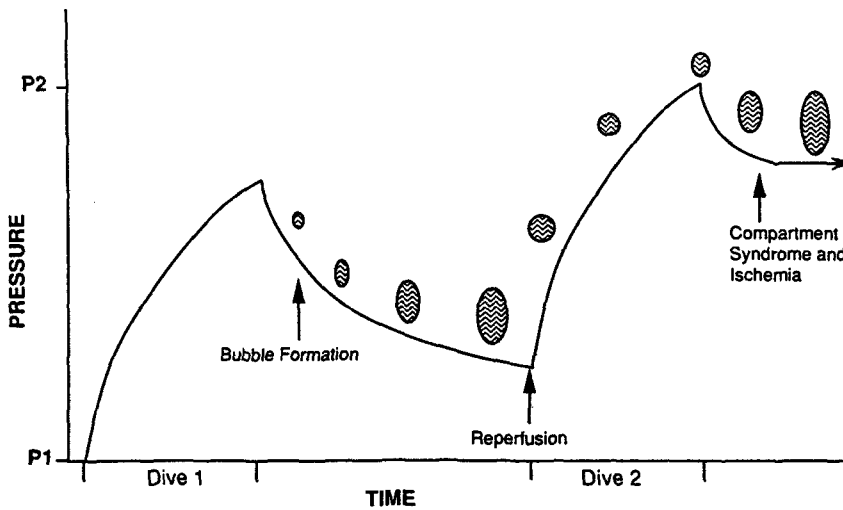

Fig. 5. Latent bubbles, tissue reperfusion, bubble growth, and a compartment syndrome. In repetitive diving, tissue reperfusion in successive dives may promote large bubble growth in vulnerable tissues and cause a compartment syndrome.

Figures 3-5 have illustrated some possible decompression outcomes which include a compartment syndrome. Collectively, they suggest the complexity of repetitive diving when dealing with tissue inert gas washin and washout rates. They also suggest that modeling dive tables in closely-spaced repetitive diving becomes very complicated.

### Conclusions

Some of the principles explored in repetitive diving are especially important in understanding human responses to this form of diving. Adaptation can decrease the risk of DCS. Slower tissues would appear to be most significantly loaded with additional N<sub>2</sub>. Tissue architecture and composition significantly influence a tissue's vulnerability to decompression injury. With tissue bubble formation, tissues that ordinarily would not be vulnerable to decompression injury in a single dive, may become vulnerable in successive repetitive dives. Latent bubbles may increase tissue washout times and increase the risk of DCS and bone necrosis. The hypothesized latent bubble mechanism of increasing washout times may be especially important in connection with comparatively fast tissues represented in the spinal cord. The relatively high percentage of spinal cord involvement in DCS cases after repetitive diving may reflect the importance of this hypothesized mechanism.

### Acknowledgments

The author thanks Mr. Blair A. Rhode and Ms. Naomi Wells for their assistance in the preparation of this paper. The author also thanks Dr. Edward H. Lanphier for his discussions of DCS and DON, and Mr. Yasushi Taya (JAMSTEC) and Dr. Yoshihiro Mano (Tokyo Medical and Dental University) for the dive profile of a Japanese diving fisherman (Fig. 2). This work was funded by the University of Wisconsin Sea Grant Institute under grants from the National Sea Grant College Program, National Oceanic and Atmospheric Administration, U.S. Department of Commerce, and from the State of Wisconsin. Federal grant NA90AA-D-SG469, project R/DP-6.

### Literature Cited

- Amako, T., M. Kawashima, T. Torisu, and K. Hayashi. 1974. Bone and joint lesions in decompression sickness. *Seminars Arthr. Rheum.* 4: 151-190.
- Atkins, C.E., C.E. Lehner, K.A. Beck, R.R. Dubielzig, E.V. Nordheim, and E.H. Lanphier. 1988. Experimental respiratory decompression sickness in sheep. *J. Appl. Physiol.* 65: 1163-1171.
- Batson, O.V. 1940. The function of the vertebral veins and their role in the spread of metastases. *Ann. Surg.* 112: 138-149.
- Behnke, A.R. 1945. Decompression sickness incident to deep sea diving and high altitude ascent. *Medicine* 24: 381-402.
- Boycott, A.E., G.C.C. Damant, and J.S. Haldane. 1908. Prevention of compressed-air illness. *J. Hyg., London* 8: 342-443.
- Davidson, J.K. 1976. Dysbaric osteonecrosis. *Aseptic Necrosis of Bone*. J.K. Davidson (Ed.). Elsevier, New York, pp. 147-212.
- Davidson, J.K. 1989. Dysbaric disorders: aseptic bone necrosis in tunnel workers and divers. *Bailliere's Clin. Rheumatol* 3: 1-23.

- Divers Alert Network. 1991. 1989 Report on Diving Accidents and Fatalities. Divers Alert Network, Durham, NC.
- Eckenhoff, R.G. 1989. Adaptation to decompression stress. *In: The Physiological Basis of Decompression.* R.D. Vann, (Ed.). Undersea and Hyperbaric Medical Society, Inc., Bethesda, MD, pp. 345-347.
- Elliott, D.H. 1969. Some factors in the evaluation of oxy-helium decompression schedules. *Aerospace Med.* 40: 129-132.
- Evans, A., and D.N. Walder. 1969. Significance of gas micronuclei in the aetiology of decompression sickness. *Nature* 222: 251-252.
- Ficat, R.P., and J. Arlet. 1980. *Ischemia and Necroses of Bone.* D.S. Hungerford (Ed.). Williams and Wilkins, Baltimore.
- Francis, T.J.R., J.L. Griffin, L.D. Homer, G.H. Pezeshkpour, A.J. Dutka, and E.T. Flynn. 1990. Bubble-induced dysfunction in acute spinal cord decompression sickness. *J. Appl. Physiol.* 68: 1368-1375.
- Francis, T.J.R., G.H. Pezeshkpour, A.J. Dutka, J.M. Hallenbeck, E.T. Flynn. 1988. Is there a role for the autochthonous bubble in the pathogenesis of spinal cord decompression sickness? *J. Neuropathol. Exp. Neurol.* 47: 475-487.
- Golding, F.C., P. Griffiths, H.V. Hempleman, W.D.M. Paton, and D.N. Walder. 1960. Decompression sickness during construction of the Dartford Tunnel. *Brit. J. Industr. Med.* 17: 167-180.
- Haldane, J.S., *et al.* 1907. Report of the Admiralty Committee on Deep-Water Diving. Parliamentary Paper. C.N. 1549. HMSO, London.
- Hallenbeck, J.M. 1976. Cinemicrography of dog spinal vessels during cord-damaging decompression sickness. *Neurology* 26: 190-199.
- Hallenbeck, J.M., and J.C. Andersen. 1982. Pathogenesis of decompression disorders. *In: The Physiology and Medicine of Diving*, 3rd ed., P.B. Bennett and D.H. Elliott (Eds.). Bailliere Tindall, London, pp. 435-460.
- Hallenbeck, J.M., A.A. Bove, and D.H. Elliott. 1975. Mechanisms underlying spinal cord damage in decompression sickness. *Neurology* 25: 308-316.
- Harley, N.H. 1989. Radon. Proceedings of the Twenty-fourth Annual Meeting 30-31 March, 1988. N.H. Harley (Ed.). National Council on Radiation Protection and Measurements, Bethesda, MD.
- Harvey, E.N. 1951. Physical factors in bubble formation. *Decompression Sickness, Caisson Sickness, Diver's and Flier's Bends and Related Syndromes.* J.F. Fulton (Ed.). W.B. Saunders Co., Philadelphia, pp. 90-114.
- Harvey, E.N., A.H. Whiteley, W.D. McElroy, D.C. Pease, and D.K. Barnes. 1944. Bubble formation in animals. II. Gas nuclei and their distribution in blood and tissues. *J. Cell. Comp. Physiol.* 24: 23-34.
- Hayashi, K., M. Kitano, M. Kawashima, T. Torisu, and S. Matsuoka. 1978. Studies of decompression sickness in Japanese diving fishermen. *In: Proceedings of the Sixth Symposium of Underwater Physiology.* C.W. Shilling and M.W. Beckett (Eds.). FASEB, Bethesda, MD, pp. 547-554.

- Hemmingsen, E.A. 1989. Bubble formation mechanisms. *In: The Physiological Basis of Decompression*. R.D. Vann, (Ed.). Undersea and Hyperbaric Medical Society, Inc., Bethesda, MD, pp. 153-169.
- Hills, B.A., and P.B. James. 1982. Spinal decompression sickness: mechanical studies and a model. *Undersea Biomed. Res.* 9: 185-201.
- Homer, L.D., P.K. Weathersby, and S. Survanshi. 1990. How countercurrent blood flow and uneven perfusion affect the motion of inert gas. *J. Appl. Physiol.* 69: 162-170.
- Keays, F.L. 1909. Compressed air illness, with a report of 3,692 cases. *Publ. Cornell Univ. Med. Coll.* 2: 1-55.
- Lanphier, E.H., C.E. Lehner. 1990. Animal models in decompression. *In: Man in the Sea*, Y.C. Lin and K.K. Shida (Eds.). Best Publ. Co., San Pedro, CA, Vol 1:273-295.
- Lanphier, E.H., C.E. Lehner, E.N. Lightfoot, and J.A. Will. 1984. Influence of exposure time on manifestations of decompression sickness. *Proceedings of the Seventh Meeting of the United States-Japan Cooperative Program in Natural Resources (UJNR) Panel on Diving Physiology and Technology*, M. Saeki (Ed.). Japan Marine Science and Technology Center, Yokosuka, pp. 218-227.
- Lehner, C.E., G.G. Adler, T.M. Kanikula, M. Palta, and E.H. Lanphier. 1985. Influence of dive profile on manifestations of decompression sickness. *Undersea Biomed. Res.* 12 (Suppl):12.
- Lehner, C.E., and E.H. Lanphier. 1989. Influence of pressure profile on DCS symptoms. *In: The Physiological Basis of Decompression*, R.D. Vann (Ed.). Undersea and Hyperbaric Medical Society, Inc., Bethesda, MD, pp. 299-322.
- Matsen, F.A. 1975. Compartmental syndrome, an unified concept. *Clin. Orthop.* 113: 8-14.
- McCallum, R.I., and J.A.B. Harrison. 1982. Dysbaric osteonecrosis: aseptic necrosis of bone. *In: The Physiology and Medicine of Diving*, 3rd ed. P.B. Bennett and D.H. Elliott (Eds.). Bailliere Tindall, London, pp. 488-506.
- Mubarak, S.J., and A.R. Hargens. 1981. *Compartment Syndromes and Volkmann's Contracture*. W.B. Saunders, Philadelphia.
- Nashimoto, I., and E.H. Lanphier, (Eds.). 1991. *What is bends?* Undersea and Hyperbaric Medical Society, Inc., Bethesda, MD.
- National Council on Radiation Protection and Measurements. 1987. *Ionizing Radiation Exposure of the Population of the United States*. NCRP Report No. 93. National Council on Radiation Protection and Measurements, Bethesda, MD.
- Netter, F.H. 1989. *Atlas of Human Anatomy*. Ciba-Geigy Corp., Summit, NJ.
- Novotny, J.A., D.L. Mayers, Y.J. Parsons, S.S. Survanshi, P.K. Weathersby, and L.D. Homer. 1990. Xenon kinetics in muscle are not explained by a model of parallel perfusion-limited compartments. *J. Appl. Physiol.* 68: 876-890.
- Okang, G.I., and R.D. Vann. 1989. Bubble formation in blood and urine. *In: The Physiological Basis of Decompression*, R.D. Vann (Ed.). Undersea and Hyperbaric Medical Society, Inc., Bethesda, MD, pp. 177-178.

- Palmer, A.C. 1986. The neuropathology of decompression sickness. *Recent Advances in Neuropathology*, No. 3, J.B. Cavanaugh (Ed.). Churchill Livingstone, New York, pp. 141-162.
- Palmer, A.C., W.F. Blakemore, and A.G. Greenwood. 1976. Neuropathology of experimental decompression sickness (dysbarism) in the goat. *Neuropath. Appl. Neurobiol.* 2: 145-156.
- Palmer, A.C., W.F. Blakemore, J.E. Payne, and A. Sillence. 1978. Decompression sickness in the goat: nature of brain and spinal cord lesions at 48 hours. *Undersea Biomed. Res.* 5: 275-286.
- Paulev, P. 1965. Decompression sickness following repeated breath-hold dives. *J. Appl. Physiol.* 20: 1028-1031.
- Schmidt-Nielsen, K. 1984. *Scaling, why is animal size so important?* Cambridge University Press, Cambridge.
- Vann, R.D., W.A. Gerth, and N.E. Leatherman. 1989. Exercise and decompression sickness. *In: The Physiological Basis of Decompression.* R.D. Vann, (Ed.). Undersea and Hyperbaric Medical Society, Inc., Bethesda, MD, pp. 119-137.
- Vann, R.D., J. Grimstad, and C.H. Nielsen. 1980. Evidence for gas nuclei in decompressed rats. *Undersea Biomed. Res.* 7: 107-112.
- Walder, D.N. 1966. Adaptation to decompression sickness in caisson work. *Biometeorology II. Proceedings of the Third International Biometeorological Congress held at Pau, S. France, 1-7 September, 1963.* Pergamon Press, Oxford, pp.350-359.
- Walder, D.N. 1990. Aseptic necrosis of bone. *In: Diving Medicine*, 2nd ed. A.A. Bove, and J.C. Davis (Eds.). W.B. Saunders Co., Philadelphia, pp. 192-199.
- Walder, D.N., and A. Evans. 1974. *In vivo* nuclear fission in the aetiology of decompression sickness. *Nature* 252: 696-697.
- Ward, C.A., D. McCullough, D. Yee, D. Stanga, and W.D. Fraser. 1990a. Complement activation involvement in decompression sickness of rabbits. *Undersea Biomed. Res.* 17: 51-66.
- Ward, C.A., D. McCullough, D. Yee, D. Stanga, and W.D. Fraser. 1990b. The role of complement activation in decompression sickness. *In: Man in the Sea*, Vol. 1. Y.C. Lin and K.K. Shida, (Eds.). Best Publishing Co., San Pedro, CA, pp. 253-271.
- Williams, E.A., R.H. Fitzgerald, Jr, P.J. Kelly. 1984. Microcirculation of bone. *In: The Physiology and Pharmacology of the Microcirculation*, Vol 2, N.A. Mortillaro (Ed.). Academic Press, Inc., Orlando, FL, pp. 267-323.
- Yount, D.E. 1990. The physics of bubble formation: implications for improvement of decompression tables. *In: Man in the Sea*, Vol. 1, Y.C. Lin, and K.K. Shida (Eds.). Best Publishing Co., San Pedro, CA, pp. 231-251.
- Zülch, K.J., and R. Kurth-Schumacher. 1970. The pathogenesis of "intermittent spinovascular insufficiency" ("spinal claudication of Dejerine") and other vascular syndromes of the spinal cord. *Vasc. Surg.* 4:116-136.



## DECOMPRESSION-INDUCED BUBBLE FORMATION IN HUMANS AFTER SHALLOW SATURATION DIVES

*Roderic G. Eckenhoff*  
Institute for Environmental Medicine  
University of Pennsylvania  
1 John Morgan Building  
Philadelphia, PENNSYLVANIA 19104-6068 U.S.A.

### Introduction

It is well accepted that the pathophysiology of the decompression sickness syndromes proceeds through the formation of a gas phase after decompression (Hallenbeck and Andersen, 1982). However, the physiologic fate and sequelae of the gas phase is poorly understood. Through the use of bubble detection technology, it has become clear that: 1) both vascular and stationary bubbles do occur in humans after a decompression; 2) the risk of experiencing symptoms rises with the magnitude of detected bubbles (Sawatsky and Nishi, 1990); and 3) symptomless, or "silent", bubbles are very common (Eckenhoff *et al.*, 1986). Although substantial variability in gas phase formation occurs both between and within subjects, it is likely that gas phase formation is less variable than symptom generation. Taken together with the intuitive value of studying etiologic factors instead of pathologic results, the study of gas phase formation is an attractive approach to the understanding of decompression sickness (Spencer, 1976; Eckenhoff, 1985).

### Saturation Time

In an attempt to further reduce sources of variation in the study of decompression sickness, all our decompressions were from conditions of steady state inert gas exchange, or "saturated" conditions. Such conditions are relevant to the topic of this workshop, not only because it simplifies the study of decompression sickness, but because saturation is the upper limit of repetitive diving. But the definition of saturation with respect to decompression and bubbles is variable and elusive. From an examination of nitrogen uptake and elimination curves under isobaric conditions, one might expect that saturation with a new increased partial pressure of nitrogen should be achieved in less than an hour, yet the inclusion of exceedingly slow half time compartments (360, 720 min) in decompression table formulations suggest that saturation may take longer than 12 hours. Indeed, some investigators have concluded that saturation, at least with respect to decompression sickness, is not complete for 48 hours or more. There is however, little evidence for this, and there have been no studies of saturation time with respect to gas phase formation.

In an effort to provide relevant information, we examined the time for saturation as defined by venous bubbles in a group of 128 human subjects (Eckenhoff and Olstad, 1991). Groups of thirty-two subjects each were exposed to air at a pressure equivalent to 20.5 fswg in an underwater habitat for 3, 6, 12 or 48 hours. After direct decompression to the surface (no intervening decompression stops or oxygen breathing), the subjects were monitored at regular intervals (0.5, 1, 2, 3, 4, 5, 6, 9, 12 and 24 hrs) with a Doppler ultrasound device over the precordium and subclavian veins. Figure 1 shows the results of this series of exposures. The incidence of detectable bubbles (grade 1 or higher by two independent scorers using Kisman-Masurel code (Kisman and Masurel, 1978)) after decompression appeared to reach a plateau of around 80% quickly; with between 3 and 6 hours of exposure to 20.5 fswg. However, the magnitude of bubbling, as expressed by the bubble score or duration that bubbles could be detected,

continued to increase to exposures of 12 hours. No significant difference between score or duration could be detected after decompression from exposures of 12 or 48 hours.

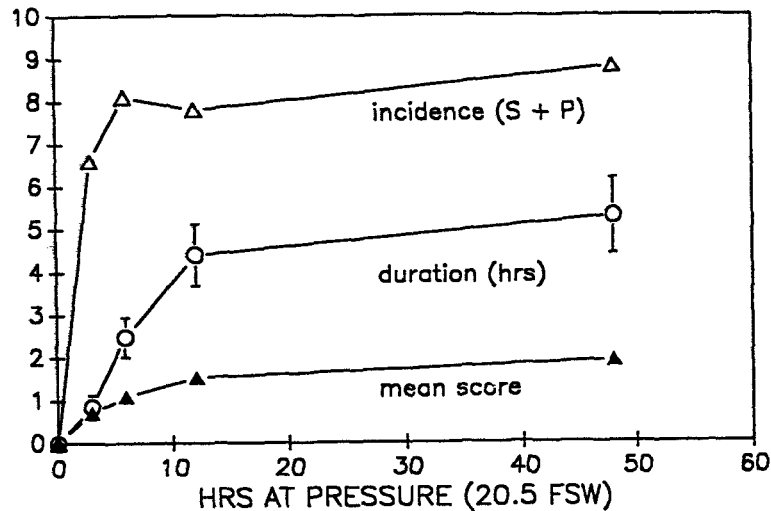

Figure 1. Time for saturation. Triangles are 0.10 times the incidence of subjects with detectable bubbles (score > 0) after decompression from 20.5 fsw for the duration listed on the y-axis. The circles represent the duration that bubbles could be detected after decompression for the same exposures, and the filled triangles are the mean bubble score.

This suggests that, with respect to gas phase formation, saturation with nitrogen is essentially complete after 12 hours of exposure. Further, the difference between the incidence and magnitude data suggests that the bubble generation site and inert gas storage site are different; bubbles appear to be generated in fairly "fast" tissues, which are then "fed" by longer half time tissues. Since saturation time is theoretically independent of partial pressure gradient (depth), it is likely that these results can be extrapolated to exposures of different depths. Despite this finding (saturation in 12 hours), we have continued to use 48 hours for many of our experiments for two reasons. First, the habitat used for these experiments does undergo some tidal pressure fluctuations, and the longer time period may dampen the effect on inert gas uptake. Second, the longer time simply ensures saturation with a greater degree of confidence, and therefore reduces the impact of physiologic heterogeneity on inert gas uptake as a source of variation.

### Decompression Potency

In an attempt to understand the mechanisms that link decompression and gas phase formation, it would be useful to know the "potency" of decompression for producing gas phase. Such dose-response data for humans was not readily available in the literature, so we have performed several experiments designed to produce such relationships. A total of 145 human subjects were exposed to 12, 16, 20.5, 25.5 and 30.5 fswg for 48 hours (Eckenhoff *et al.*, 1986; 1990), with Doppler monitoring performed as described above. Figure 2 shows the dose-response curves constructed from the results of these studies. The inset to this figure shows that the dose response curves are shifted to the left by including the subclavian data. Indeed, it is possible that the efficiency of bubble detection may increase further by monitoring more sites. It is not clear why bubbles detected in the subclavian veins are often not detected over the precordium, but possibilities include absorption prior to reaching the right ventricle or pulmonary artery, confusion of Doppler signals with the prominent myocardial/valve signals, and that bubbles may take a tract through the right heart which is not within the ultrasound beam. Nevertheless, the decompression "dose" required to produce a bubble incidence of 50% (from the Hill

equation fit by non-linear least squares) is remarkably low. With the inclusion of the subclavian data, this value is about 12 fswg. Further, it suggests that bubbles should be detectable in at least some subjects after decompression from saturation at between 5 and 8 fswg.

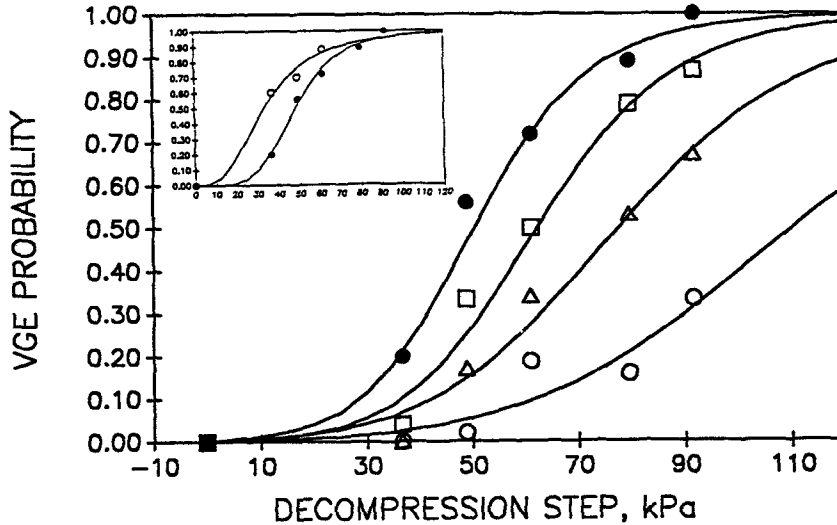

Figure 2. The curves are Hill equations fit to the raw incidence (highest score achieved in each subject) data (points) using a non-linear least squares routine. Parameters for the equations with standard errors are given in Table 1. The size of the decompression step is given in kPa, and all decompressions were to the surface (101 kPa). Data for the 78 and 90 kPa steps were from Eckenhoff *et al.* (1990). Filled circles represent the proportion of subjects with VGE scores of 1 or greater, open squares represent subjects with VGE scores of 2 or greater, open triangles are those with VGE scores of 3 or greater and open circles represent those subjects with grade 4 VGE. Fit is highly significant ( $P < .001$ ) for all of the data sets. Inset: Inclusion of the subclavian VGE data with that of the precordial site increase the sensitivity of VGE detection. The open circles represent the proportion of subjects with any detectable VGE (precordial plus subclavian), and the curve represents the fit with a Hill equation using least squares. The parameters of this left-shifted curve are  $n = 10.5 + 2.0$  and  $D(VGE)_{50} = 135 + 2.5$  kPa. Also shown for comparison is the precordial only Hill curve from Fig. 2 (note: subclavian data not available for the previously reported two higher pressure experiments)

Table 1. Hill equation parameters.

Parameter	VGE $\geq 1$	VGE $\geq 1^*$	VGE $\geq 2$	VGE $\geq 3$	VGE = 4
n	13.9 $\pm$ 1.6	10.5 $\pm$ 2.0	12.7 $\pm$ 1.5	10.0 $\pm$ 1.3	8.5 $\pm$ 2.8
$D_{(VGE)50}$	150.3 $\pm$ 1.2	135.2 $\pm$ 2.5	162.2 $\pm$ 1.6	177.4 $\pm$ 2.0	210.1 $\pm$ 10.6

(all non-linear least squares fit. \*=precordial plus subclavian data)

This very low value has important implications for the mechanism of bubble generation: supersaturation does not appear to be a requirement for bubble production. This implies that pre-existing gas spaces must exist, from which the bubbles are generated by a Boyle's law phenomena. The rate of, and continued production of bubbles, however, is almost certainly reliant on increasing degrees of supersaturation. Despite substantial bubble magnitudes in our experiments, few symptoms occurred. The 30.5 fsw exposures were accompanied by about a 30% incidence of decompression sickness. Although decompression sickness did not occur after decompressions from shallower exposures, the 25.5 fsw group had about a 25% incidence of suggestive symptoms, which were not treated. Thus we could not, nor was it our intent, to study the relationships between bubbles and symptoms.

### Latency

The experiments described thus far were no-stop decompressions to the surface, for an unlimited durations. There is clearly a latent period during and after the decompression when there are neither symptoms or detectable bubbles. It seemed likely that this latent period could be exploited for specific situations, such as emergency decompressions from greater depths than above, for evacuation, treatment or transfer. In fact, latency is exploited routinely in military and commercial surface decompression protocols. Finally, a thorough understanding of latency may yield insight into the mechanisms of both bubble and symptom generation.

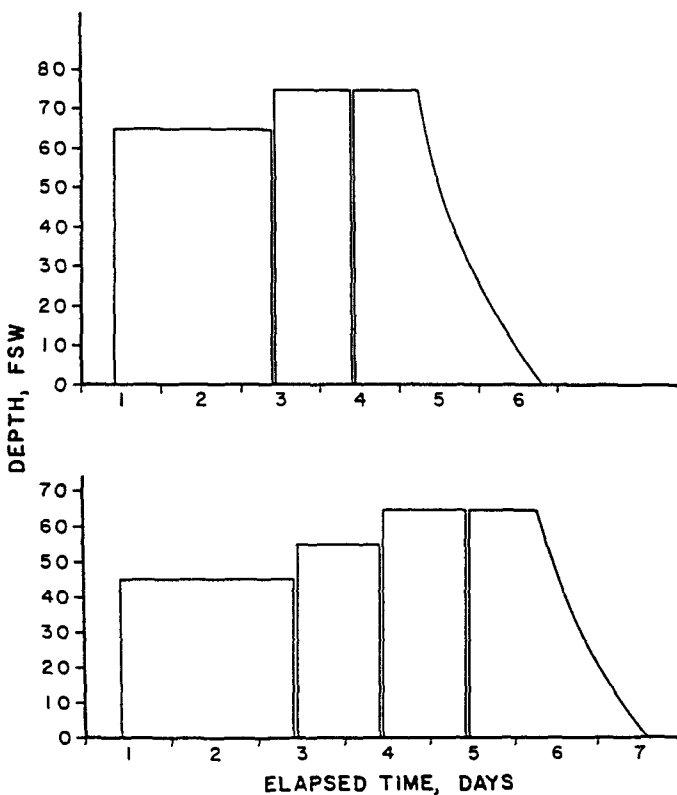
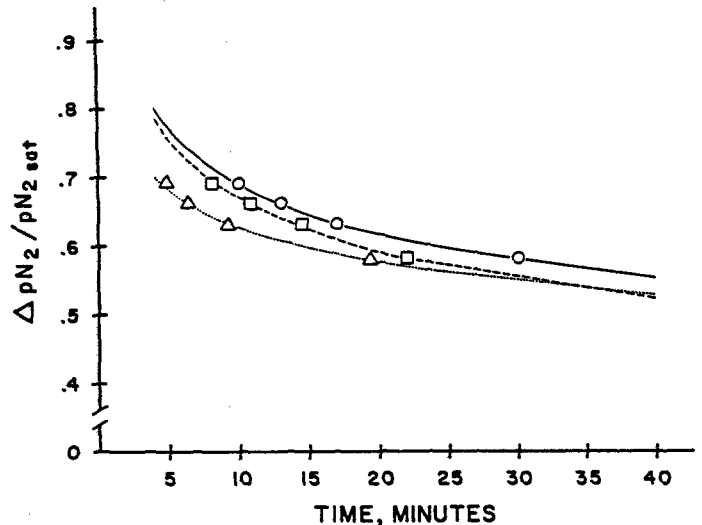

Figure 3. Graphic representation of the latency pressure exposures in a dry chamber. Lower panel was used for 18 subjects and the upper panel used for 6 subjects.

We carried a series of exposures designed to examine the relationship between latency and decompression magnitude in a group of human subjects (Eckenhoff and Parker, 1984). A total of 24 subjects participated in this series of experiments, with 18 subjects in the first dives (Fig. 3 bottom) and 6 subjects in the last (Fig. 3 top). The dry chamber could hold 3 subjects per dive. Initial upward excursion time limits were obtained from an analysis of NOAA-OPS exposures (Hamilton *et al.*, 1973).

In addition to recording symptom onset, the subjects were monitored with Doppler ultrasound for the onset of bubbles (precordium only). Results are shown in figure 4, with the appearance times for bubbles and symptoms best described by a power curve. We found that the initial excursion durations were conservative for the deep experiments, and extended these times in subsequent dives; a 10 minute surface excursion from 75 fswg saturation was symptom free (except for pruritus), and the mean time for bubble detection was 8 min. It is important to note in these experiments that the upward excursion duration was defined as including the decompression. Thus, from the deepest exposures, the available time at the surface for transfer, etc., can be substantially reduced by the amount of time required for decompression.

Figure 4. Mean times of appearance for pruritus (triangles) and bubbles (squares) versus the nitrogen partial pressure reduction ratio. The full excursion duration is also shown (circles). Curves are power curves fit to the data using least squares.



The relationship shown in fig. 4 predicts long latencies for bubbles after decompression from shallow dives. The predictive value of this relationship was tested by examining the latency for detectable bubbles in the exposures mentioned above for the potency determination (Eckenhoff *et al.*, 1986). The results of the 25.5 and 30.5 exposures in the dry chamber fit well with predictions as shown in Fig 5; a mean latency of 2 hrs was found after the 25.5 fswg exposure. However, the shallower dives performed in the wet habitat did not fit this relationship at all; latency was routinely less than 1 hr. We do not have a good explanation for this discrepancy, but the different activity levels following the two sets of experiments may be important. The subjects only stepped out and rested after the dry chamber dives, whereas the subjects were required to don and doff SCUBA equipment for the ascent after the habitat exposures. Activity/exercise after decompression from pressure or to altitude is a fairly well established risk factor for decompression sickness (Jauchem, 1988), and certainly could decrease the latency of bubbles as well. This potential variable needs to be considered in any further studies of this area, and also in any field application of this technique.

The physiological basis for latency is not clear, but certainly the mechanisms for bubble growth, mobilization and distribution require time. It is easier to understand why the appearance of symptoms requires time. However, the direct relationship between decompression magnitude and latency, although seemingly intuitive, is difficult to reconcile with the proposed pre-existing gas space hypothesis of bubble generation mentioned above. This hypothesis would suggest that, once a critical pre-existing gas space volume was exceeded, the time of venous bubble appearance in the central circulation would simply be a function of hemodynamic parameters. As stated above, however, this may be consistent with the differences in latency between the chamber and habitat exposures.

Apparently, an exploration of variables other than decompression magnitude is required for a better understanding of latency.

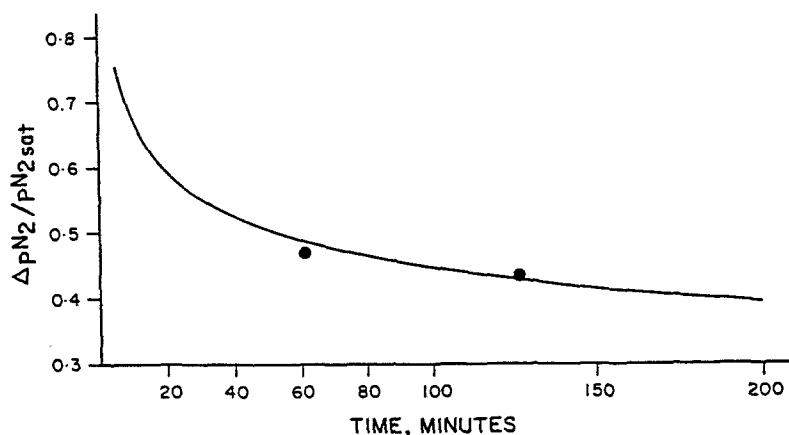

Figure 5. The relationship calculated from the Fig. 4 data is again plotted with a longer time scale, and the latency data from the 25.5 and 30.5 fswg potency dry chamber exposures are superimposed.

### Adaptation

Logistical considerations forced the design of the previously mentioned latency exposures (Fig 4) to include repetitive ascending excursions. We were worried that a given surface excursion may be influenced by the excursion which preceded it (see fig 4). Both a negative effect (accumulation of gas phase) and a positive effect (adaptation) could be hypothesized. Although we examined this possibility by repeating the excursion from 65 fswg as the initial excursion in the second series of experiments (no detectable difference if placed first or last in the series of excursions), we wanted to study this further.

Adaptation to decompression-induced stress has been widely touted in the literature to the point of becoming accepted dogma. It is also highly relevant to the subject of this workshop. The popular, though untested, mechanism for adaptation was a depletion of gas micronuclei by repetitive decompressions (Evans and Walder, 1969). If true, a decrease in decompression-induced gas phase should occur and may be measurable by Doppler techniques after a series of repetitive dives. Fifteen subjects underwent a dive to 150 fswg for 30 minutes for each of 12 consecutive days (Eckenhoff and Hughes, 1984). Precordial Doppler signals were recorded and scored blindly (with respect to both day and subject) by the DCIEM group of investigators. The results are shown in Figure 6. Although the optimal statistical handling of such scores is not clear, the scores are presented as means simply to indicate the trend over time. As is apparent from the figure, no substantial or significant trend could be observed, nor was there a trend apparent in any individual subject. The conclusion therefore, is that a change in the magnitude or rate of bubble production is not a likely explanation for adaptation. This is not to say that adaptation to decompression-induced phenomena does not occur, but we believe that the explanation is more likely to reside in the physiological fate or sequelae of bubbles, instead of a reduction in their number.

Does adaptation to decompression stress exist at all? There is sound retrospective evidence for a reduction in complaints after decompression from work in pressurized caissons, which occurred over a period of about 1 week. The complaints increased again after vacations or weekends. Unfortunately, however, the basis for a decrease in spontaneous complaints is multivariate. There is only anecdotal

mention of such a phenomena in diving activity, and animal evidence has not been consistent. It appears, then, that there is only weak support for the concept of adaptation at all, regardless of the mechanism. The practice of "work-up" dives, therefore, appears unfounded at the present time. However, since the exploitation of such a concept would have substantial practical and operational importance, the definitive study of this possibility would be most welcome.

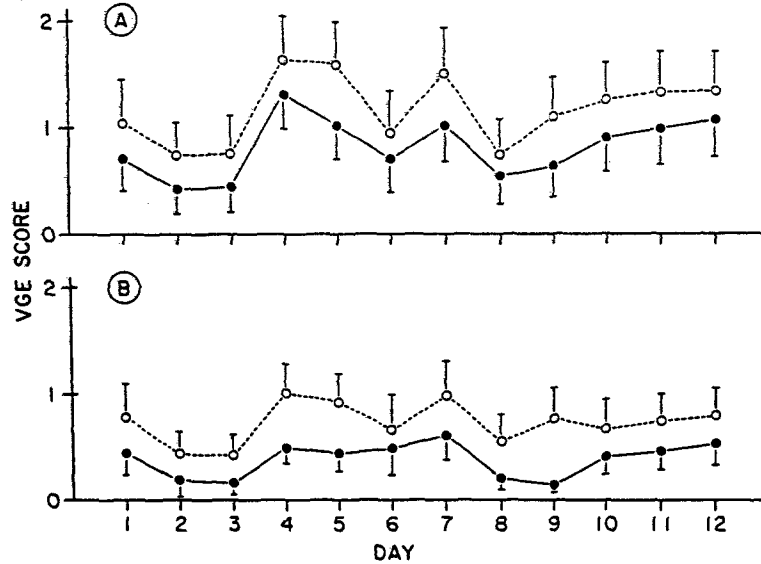

Figure 6. Mean bubble scores from 14 subjects for each of the 12 consecutive days. Open circles are the score after movement and the closed circles are that with rest. Panel A is the average peak score noted during the 2 hr monitoring session, while panel B is the mean score over the same period of time. Bars are 1 SEM.

#### References

- Bell, P.Y., J.R. Harrison, K. Page and M. Summerfield. 1986. An effect of CO<sub>2</sub> on the maximum safe direct decompression to 1 bar from oxygen-nitrogen saturation. *Undersea Biomed. Res.* 13: 443-455.
- Eckenhoff, R.G., Olstad, C.E. and G.E. Carrod. 1990. Human dose-response relationship for decompression and endogenous bubble formation. *J. Appl. Physiol.* 69: 914-918.
- Eckenhoff, R.G., Osborne, S.F., Parker, J.W., K.R. Bondi. 1986. Direct ascent from shallow air saturation exposures. *Undersea Biomed. Res.* 13: 305-316.
- Eckenhoff, R.G. and J.W. Parker. 1984. Latency in the onset of decompression sickness on direct ascent from air saturation. *J. Appl. Physiol.* 56: 1070-1076.
- Eckenhoff, R.G. and J.S. Hughes. 1984. Acclimatization to decompression stress. *In: Bachrach AJ, Matzen MM. eds. Underwater Physiology VIII, Proceedings of the Eighth Symposium on Underwater Physiology.* Bethesda: Undersea Medical Society, Inc., pp. 93-100.
- Eckenhoff, R.G. and C.S. Olstad. 1991. Time for saturation in humans as defined by venous gas bubbles. *Undersea Biomed. Res.* 18 (in press).
- Eckenhoff, R.G. 1985. "Doppler bubble detection". *Undersea Biomed Res* 12: 485.

- Evans, A., and D.N. Walder. 1969. Significance of gas micronuclei in the aetiology of decompression sickness. *Nature* 222: 251-252.
- Hallenbeck, J.M. and J.C. Andersen. 1982. Pathogenesis of the decompression disorders. *In: The Physiology and Medicine of Diving*, P.B. Bennett and D.H. Elliott (Eds.). San Pedro, Best Publishing Co. pp 435-460.
- Hamilton, R.W., D.J. Kenyon, M. Freitag and H.R. Schreiner. 1973. NOAA-OPS I and II: formulation of excursion procedures for shallow undersea habitats. Union Carbide Tech, Memo. UCRI 731.
- Jauchem, J.R. 1988. Effects of exercise on the incidence of decompression sickness: A review of pertinent literature and current concepts. *Int. Arch. Occup. Environ. Health* 60: 313-319.
- Kisman, K.E. and G. Masurel. 1978. Bubble evaluation code for Doppler ultrasonic decompression data. *Undersea Biomed. Res.* 5: A28
- Sawatzky, K.D. and R.Y. Nishi. 1990. Intravascular Doppler detected bubbles and decompression sickness. *Undersea Biomed Res* 17: A34.
- Spencer, M.P. 1976. Decompression limits for compressed air determined by ultrasonically detected blood bubbles. *J. Appl. Physiol.* 40: 229-235.



## QUANTIFICATION OF SYMPTOMS IN DECOMPRESSION ILLNESS

*Richard E. Moon*  
*Claude A. Piantadosi*  
Box 3823

F.G. Hall Hyperbaric Laboratory  
Duke University Medical Center  
Durham, NORTH CAROLINA 27710 U.S.A.

### Introduction

Bubble formation in decompression sickness may be due to one of two mechanisms: 1) *in situ* bubble formation due to supersaturation of inert gas partial pressure during and after decompression and 2) barotrauma of the lungs or paranasal sinuses. Gas bubbles may be clinically important and require recompression therapy if they are in the central nervous system, musculo-skeletal system, lymphatics or pulmonary circulation (if symptomatic). Gas may also occur in the mediastinum, pleurae, subcutaneous tissue, or the subdural space and not require recompression therapy. Commonly used classification schemes usually address only bubble disease which requires treatment.

One type of traditional classification of decompression illness has been on the basis of anatomical location of gas (see table 1).

**Table 1. Anatomical classification of decompression sickness**

- Musculoskeletal
- Lymphatic
- Skin
- Central Nervous System
  - Brain
  - Spinal cord
- Peripheral Nervous System
- Inner ear

Another classification is based upon a combination of anatomical location and pathophysiological mechanism. In this scheme, decompression disorders are divided into types I and II DCS, and arterial gas embolism. This classification has been useful as a guide to therapy and return to diving (table 2).

It is suggested that mild decompression sickness may be treated with a short table (e.g. USN Table 5), more severe decompression sickness by a longer table (e.g. USN Table 6) and arterial gas embolism by USN Table 6A. Subsequent management and return to diving has also traditionally been based upon the particular syndrome (DCS type I, type II, or AGE).

**Table 2. Traditional "Therapeutic" Classification**

<i>Syndrome</i>	<i>Presentation</i>	<i>Treatment</i>	<i>Typical Management</i>
• DCS Type I	Musculoskeletal Skin	USN Table 5	Return to diving 3 days after symptoms resolved
• DCS Type II	Neurological Cardiorespiratory Inner Ear	USN Table 6	Return to diving 1 month after symptoms resolved
• AGE	Neurological Other	USN Table 6A	Individual evaluation

There are several difficulties with these classification schemes. First, decompression illness is often multisystemic. Patients with neurological decompression sickness often have joint pain in addition, and may also present symptoms suggestive of both brain and spinal cord involvement. Second, clinical localization is often inaccurate. For example, patients presenting with vertigo, nausea, and vomiting may have involvement of the inner ear or brainstem, and differentiation between these possibilities cannot usually be made on clinical grounds alone. Third, the assumptions upon which the "therapeutic" classification were based may not be valid. There is animal evidence to suggest that USN table 6 may be as appropriate as table 6A for treatment of AGE (Leitch *et al.*, 1984). The effectiveness of different treatment tables may also depend upon other clinical parameters not traditionally taken into consideration, for instance the degree to which tissues have been preloaded with inert gas. For example, divers experiencing AGE after short, shallow dives, low tissue inert gas load and after long, deep dives (tissues pre-loaded with inert gas) may require different treatment tables. In the former situation, the thirty minute time interval spent at 6 ATA during USN Table 6 may cause prompt reduction of bubble volume according to Boyle's law and an excellent clinical result. In the latter situation, anecdotal clinical observations have suggested that clinical deterioration can occur after decompression from a period of air breathing at 6 ATA, possibly due to additional tissue inert gas bubble formation during the subsequent decompression. Moreover, the clinical differentiation between AGE and DCS can be impossible to make.

Furthermore, other parameters which have not traditionally been incorporated in diagnostic classifications may provide therapeutic and prognostic information. For example, preliminary analysis of recreational diving accidents from the DAN database suggests that rate of onset of symptoms may be a useful prognostic indicator. Independent of severity, individuals who experience symptom onset within a few minutes of surfacing are more likely to have residual signs and symptoms than individuals who have delayed onset. Another look at the clinical presentation of diving-related illness may be warranted.

#### **Proposed Classification**

The classification below represents the conclusions of a workshop held at the Institute of Naval Medicine, Alverstoke, UK in October of 1990, the proceedings of which have now been published (Francis and Smith, 1991). The outline is shown in table 3.

**Table 3. Preferred Classification of Decompression Illness**  
**[reproduced from Francis and Smith, 1991]**

**1. Evolution**

- Spontaneous recovery
- Static
- Relapsing (initial improvement with relapse or development of new symptoms)
- Progressive

**2. Organ System(s)**

- Neurological
- Cardiopulmonary
- Limb pain
- Skin
- Lymphatic
- Vestibular
- Pulmonary barotrauma without evidence of neurological involvement
- "Nonspecific" (e.g. headache, fatigue, malaise, anorexia, nausea, vomiting)

**3. Time of Onset**

- Minutes after reaching the surface. (There may be occasions when the exact timing of onset is not possible. When possible an estimate should be made).

**4. Gas Burden**

- There are a number of possible ways in which the residual gas burden in the diver could be estimated. These include the repetitive dive group from any of a number of tables; a simple listing of the dive depths, times, and surface intervals; or the Weathersby pDCS (Weathersby *et al.*, 1984, 1986), based on the maximum likelihood analysis of a select USN diving accident database or a crude scale based upon depth, time and surface interval. For descriptive purposes, it may be possible to use a crude index of low, medium or high. Alternatively, an exact pDCS could be used.

**5. Evidence of Barotrauma (Yes, No)**

- Pulmonary. (Acceptable evidence for pulmonary barotrauma would be hard physical signs, such as pneumothorax, surgical emphysema, or radiological evidence of extrapulmonary gas.
- Ear
- Sinus
- Other

The proposed wording of the terminology used to describe compressed gas illness would be as follows. The terms decompression sickness and arterial gas embolism should be discarded in favor of the term decompression illness, to be modified as necessary:

**Acute [Evolution term], [Manifestation term(s)], Decompression Illness**

Evolution term refers to the pattern of resolution or progression as noted in Table 3 (Evolution section). Manifestation terms are symptoms noted in Table 3 (Organ Systems). A more detailed description of the terms can be found in the workshop report (Francis and Smith, 1991) .

Incorporation of more complete descriptive features of the divers' symptomatology while collecting data may provide new insights into patterns of disease. Important prognostic information might be derived from simple clinical data and could be used as a guide to treatment.

#### References

- Francis, T.G.R. and D.J. Smith (Eds.). 1991. Describing Decompression Illness. Undersea and Hyperbaric Medical Society Publication # 79 [DECO 5/15/91], Bethesda, MD.
- Leitch, D.R., L.J. Greenbaum Jr. and J.M. Hallenbeck. 1984. Cerebral arterial gas embolism I: Is there any benefit in beginning HBO treatment at 6 bar? *Undersea Biomed Res* 11: 221-235.
- Weathersby, P.K., L.D. Homer and E.T. Flynn. 1984. On the likelihood of decompression sickness. *J Appl Physiol.* 57: 815-825.
- Weathersby, P.K., S.S. Survanshi, J.R. Hays and M.E. MacCallum. 1986. Statistically based decompression tables III: Comparative risk using US Navy, British and Canadian standard air schedules. NMRI Report 86-50. Bethesda: Naval Medical Research Institute.

**Physiology, Medicine & Environment Session Discussion**

Richard D. Vann, Moderator

- J. Lewis: Could you explain the 8 to 10 fsw bubble threshold?
- R. Eckenhoff: We were looking at the incidence of grade one or higher bubbles. The threshold which was determined by statistical methods indicated that half the people would have bubbles after a decompression from saturation at 8 to 10 feet.
- C. Fife: I monitored five Turkish divers who made two dives per day for six days per week for a month. The project was Doppler Purgatory because it lasted so long. We did not see any significant change in bubble grades for a month. But, there was a fairly reproducible trend for the bubble grade on the second dive of the day to be lower than the first dive of the day. We saw this again when we repeated the dives in the dry chamber run too. Why should the second dive produce a statistically significant lower grade?
- R. Eckenhoff: I looked at only 24 hour intervals, one per day, so I cannot really comment on it. The tunnel data which has given us our basis for the concept of adaptation was one per day, but they were eight hour exposures and so the surface interval was, in fact, 16 hours. I cannot really comment because I do not have data with that short an interval. It is certainly possible that a shorter interval could produce that observation.
- R. Vann: It is possible that more oxygen breathing after the second dive led to fewer bubbles.
- P. Bennett: Chris Wachholz and others have been taking Doppler on recreational divers on liveboards. They found bubbles early in the week. By the end of the week, there seemed to be fewer bubbles. This was recreational bounce diving rather than saturation diving which can be quite different.
- R. Eckenhoff: Your point is well taken, but I believe the incidence of your bubbling was sufficiently low that you could not be statistically confident of the decrease.
- P. Bennett: Yes, it was surprisingly low. We expected it to be very high considering that DCS is associated with repetitive diving.
- R. Eckenhoff: We deliberately chose exposures that would produce bubbles. 85 or 90 % of our subjects had bubbles, to give us a base for comparison
- R. Hamilton: An agreement with Caroline Fife's observations, we saw fewer bubbles during afternoon repetitive excursion dives from saturation in the REPEX project. DCIEM made similar observations for repetitive diving at sea level, and NASA found fewer bubbles during afternoon EVA's.
- C. Lehner: Perhaps the second dive being clear of bubbles provides evidence for the loss of micro-nuclei or micro-bubbles.
- R. Hamilton: We did our calculations on the basis of gas load. We reasoned that more or fewer bubbles might occur by provoking or eliminating gas nuclei. But, we knew it would cause a gas loading effect so we used gas loading to calculate the repetitive excursion, and with a little testing, it seems to have worked out.
- P. Tikuisis: It seems there is some controversy about adaptation here. We see no change in the bubble occurrence over multi-day diving and yet there is a decreasing occurrence in the incidence of decompression sickness. I would like the panel to consider the hypothesis put forward by Charles Ward on complement activation, which I think fits. It is consistent with both observations. Through the animal studies, he has shown that bubble activity will decomplement one's complement system and that is in line with the decreasing decompression sickness.
- R. Vann: Yes, I agree. That is certainly as good a hypothesis as others that we have considered, but I do not think we have enough evidence concerning any one of them to really nail it down at present.
- C. Lehner: I would add our observations of elevating marrow pressure in the long bones of sheep whereby we sustained, presumably, ischemia for about 12 hours duration with an elevated intermedullary pressure. Following that, we sacrificed the animal and two weeks later looked at the extent to which the marrow itself was vascularized. It was highly vascularized so there might be some vascularization that is occurring at some of the sites of tissue injury that would alter

- symptoms. This is one possible explanation for a decrease in limb bends symptoms with successive hyperbaric exposures, referred to as adaptation.
- R. Eckenhoff: I think the complement story is a good one. It is one of the first steps to start dissecting out individual variability. However, I think it is a bit simple at this point. There is a whole cascade of things ranging from vasoactive mediators, homeostatic factors and so forth that are activated by platelets, the endothelium, the vasculature itself, and it is a hugely complex system. Depending on a single factor like complement I think is too simplistic, although it is an attractive start. I do not think Dr. Ward has made the connection between adaptation and complement yet. At least the studies that I have seen have not answered the definitive question "Does adaptation deplete complement and do depleted animals produced by adaptation, in fact, decrease bends?" He depleted the animals chemically, as I recall, not through adaptation by repetitive diving.
- P. Tikuisis: Dr. Ward has done some experiments with repetitive diving but they are not published yet. You will hear about it next year.
- G. Beyerstein: Anytime I get a bend, I track the last 72 hour history, looking at multi-day and repetitive dives. I have noticed over the years that my bends tend to fall into two categories, if I eliminate table compromise where there are actual errors in the table or other factors. The nature of commercial diving is repetitive and multi-day, in many cases at the same depth on the same dive profile with the same crew for weeks at a time. These people will dive continuously for a long period of time and not get hit and then, all of a sudden, somebody gets zapped. We talked about acclimation, but nobody has mentioned anything about the reverse phenomenon of sensitization. I would like you to comment on that. Another question concerns bone necrosis. If it is a factor in diving, why are we not seeing it on our x-rays?
- R. Moon: There are probably two factors involved in multi-day diving. At the end of a long week of diving, you may be more predisposed to bends because slow tissues have gas which has gradually built up. At the same time, you may be less likely to develop bends because bubble nuclei have been depleted.
- G. Beyerstein: If you see a long dive pattern over a period of weeks with the same crew, they would have reached a steady-state, I would think. So, it may be some sort of an individual phenomenon where one guy gets it and the other does not.
- R. Moon: Well, I would not disagree with biological variability.
- R. Eckenhoff: I would just blame it all on individual variability. I think that decompression sickness is a random event and I think it shows that there is no acclimatization. You are right on the edge.
- R. Vann: This randomness may reflect a greater DCS probability late in a dive series, but as Peter Bennett frequently asks, why does DCS occur rather than adaptation during multi-day repetitive diving? These phenomena are not necessarily mutually contradictory. We could be faced with two different mechanisms. With caisson workers who make long exposures with a single bubble-forming decompression at the end of the day, there may be a reduction in gas nuclei or depleting. With multi-day repetitive no-stop diving by recreational divers, however, there are more opportunities for bubbles to form and grow, and bubbles are eliminated more slowly than an equivalent quantity of dissolved gas. Thus, adaptation in caisson workers may not be mutually exclusive from late DCS in recreational divers.
- M. Powell: We had a hint that Doppler bubbles were profile dependent in the four dives per day for six days. It seemed that dives after the deeper dives had fewer bubbles than the long shallow dives.
- C. Lehner: Perhaps a simple explanation for the absence of bone necrosis in the commercial population is that individuals with minimal symptoms are routinely treated by recompression. The mechanism of limb bends pain may be associated with elevated intermedullary pressure or distortion of the periosteal sheath around bones. Treatment may alleviate the development of bone necrosis in the diver. Treatment may be reducing the incidence of dysbaric osteonecrosis in the commercial diving population. You are simply treating "niggles", or something that is somewhat

more severe than niggles. Yet, if our bone compartment syndrome is correct, untreated limb bends could lead to the development of bone necrosis in the diver.

- G. Egstrom: Paul Anderson observed long ago, "I have never encountered a problem however complicated which, when viewed in the proper perspective, did not become more complicated!" What we are seeing is that the more we know, the more we realize what we do not know. We have been dealing with specifics rather than the whole problem. In studies of adaptation, you get a very high degree of adaptation early on and less thereafter. This may be a function of a number of different variables that we may never completely understand. I am fascinated that the Haldane two-to-one ratio was just stepped on again. If you are finding bubbling at four to six pounds of differential pressure, that puts a whole additional light on this problem of multi-day, multi-level, diving.
- J.P. Imbert: There is a lot of cold diving going on in the Mediterranean close to Corsica, Sardinia. The divers very often come to COMEX for a visit and whenever I can, I talk with them and try to question them on the tables. It appears they do two dives per day for six months to 80 to 100 meters with 25 minutes at the bottom and have one single stop according to how they feel. The only thing which is significant is that they all use extra deep stops. For a dive to 80 meters, they would spend five minutes at around 40-45 meters waiting for the umbilical to be sent down to them. What would be your explanation for this? How would you like to put a model on that?
- R. Vann: If you look back at Haldane's original schedules, you find that decompression stops are much deeper than in current tables. Evidence is accumulating that reducing ascent rate and adding deeper stops may be clearing out that first burst of intravascular bubbles.
- T. Fawcett: We heard several times about the screening of commercial divers for dysbaric osteonecrosis with long bone films. Intuitively, it seems to me that plane radiographs would be extremely insensitive for that process and that a bone scan would be much more sensitive?
- C. Lehner: We have just conducted a series of experiments to induce dysbaric osteonecrosis in sheep and saw early radiological evidence of necrosis. We also did bone scans and had approximately 10 hot spots showing up in the long bones of two sheep. Bone scans will detect bone lesions earlier, we think, than a radiological evaluation. But, it is remarkable how quickly, within a month and a half or so, that you are able to observe radiological changes with very high resolution x-ray evaluation.
- R. Eckenhoff: I was really intrigued by your counter-current mechanism for explaining slow tissues where you have gas exchange going between a venule and an arterial. That has been observed using a cryo-photometric oxygen saturation technique where you can see the venule oxygen tension increasing. Oxygen, of course, does more than increase the nitrogen gradient. It is also vasoactive. Has the vasoactivity ever been included in calculations of off-gassing using oxygen? Might it not exacerbate counter-current exchange?
- R. Vann: Current work at NMRI by John Novotny implicates a counter-current mechanism in retarding inert gas exchange. A number of studies have shown oxygen breathing to slow inert gas exchange, but I do not know how this relates to counter-current exchange.
- R. Eckenhoff: We have been looking at the effect of oxygen on venous bubbles. Our preliminary finding is that instead of reducing bubbles, it delays them. We have seen latent periods go from 30 minutes to an hour. The bubble grades are delayed but no changed. The issue of oxygen in decompression is not completely answered.
- R. Vann: There is a reasonable relationship between precordial bubbles and decompression sickness for air decompression, but when you breathe oxygen, that relationship seems to fall apart. Perhaps the bubbles come from several different locations, and by giving oxygen, you may wash out sites associated with decompression sickness while other sites continue to produce bubbles.
- M. Hahn: One would have to keep in mind that the Doppler only detects moving bubbles, but DCS may be caused by resting bubbles. Perhaps oxygen fights the resting bubbles more effectively than the moving ones.

- R. Vann: If you look at altitude exposures as opposed to diving, the correlation between bubbles and bends gets better. I am specifically referring to three-and-a-half hours of oxygen breathing prior to a four hour exposure at 30,000 feet. When decompression sickness occurs, the maximum bubble grade occurs in the affected limb. There is a much more specific relation between precordial bubbles and bends at altitude than in diving and this relationship seems to get worse in diving when breathing oxygen.
- J. Chimiak: Breath hold divers are subject to DCS. Why don't deep diving mammals also have this problem?
- W. Jaap: There is a paper, possibly in Scientific American, about deep diving mammals which reports evidence of osteonecrosis in the bones of whales, seals and walrus, both in fossil and recent. Thus, there is some indication that these animals suffer from being exposed to hyperbaric environments.
- R. Vann: One explanation for why diving mammals don't get DCS is that the lungs collapse so there is less gas to go into solution than in a human. Less nitrogen is available to cause problems.
- M. Walsh: Is it possible for interviewers at treatment facilities to recall the dive profiles of people who are bent diving with computers?
- R. Moon: Not yet, but I hope someday.
- M. Walsh: I would request DAN to assist the manufacturers in providing that information.
- P. Bennett: The animal studies Dr. Lehner has done suggest that depth is more critical than time for likelihood of getting decompression sickness. Is that correct?
- C. Lehner: It is still necessary to have adequate gas loading to get DCS.
- P. Bennett: But a recreational diver, since he is short-term, is only going to load inert gas by going deeper, is that not correct?
- C. Lehner: That is correct, but many recreational divers do repetitive diving, similar to the inert gas loading in a prolonged hyperbaric exposure.
- P. Bennett: Will recreational repetitive divers, therefore, expect to see aseptic necrosis? From Dennis Walder's work, necrosis has not been seen in people that are diving at less than 165 foot. If we go deeper, which is getting more common, will we see more necrosis?
- C. Lehner: There are recreational divers conducting severe prolonged repetitive exposures similar to the dive profile that I presented as an example of one that will potentially produce dysbaric osteonecrosis in Japanese fishermen.
- P. Bennett: Yes, these are important points. Maybe we should start looking at recreational divers for bone necrosis.
- C. Lehner: I think the potential exists for recreational divers involved in severe diving to be at risk.
- K. Huggins: Last year at the Marine Institute, there were shorter exposures in the habitat. Do you have had any information on these?
- R. Eckenhoff: We had done 3, 6, 12 and 48 hour dives and found the incidence of bubbling peaked within 3 to 6 hours, whereas the magnitude of the bubbles continued to increase to 12 hour exposures.
- K. Huggins: At what depths were those dives?
- R. Eckenhoff: Only for 20 feet, but theoretically, the saturation time should be depth independent.
- M. Powell: I have a few comments on oxygen and the appearance of bubbles. We had a Doppler bubble detector on a rat with a nose cone that allowed the animal to breathe oxygen. With the oxygen mask on, bubbles started disappearing in the vena cava. With the mask off, within a few heart beats they were right back again. I am skeptical about the statement that oxygen washes out bubbles because it does not appear to be true. My last comment has to do with recreational divers and osteonecrosis. A lady presented herself with a case of osteonecrosis which she said was confirmed by Dr. Beckman in Hawaii. She said she had worked for 18 years as a dive guide. So, there is a possibility that recreational divers can get that malady.



- H. Greer: Diving fishermen in California, principally, are urchin divers now. They get bent a lot. They are reluctant to be treated and reluctant to be studied. They appear to have a fair incidence of dysbaric necrosis. About the only time one sees them is when they have osteonecrosis adjacent to their joint surfaces and really get sick. Their diving pattern is three, four, five dives per day to 40, 60 or 80 feet, rarely as deep as 100 feet and they dive for an hour, hour and ten minutes at a time.
- C. Lehner: The pattern would seem to be very similar to the Japanese diving population, as well as those in Taiwan.
- H. Greer: Yes, very similar and they also use Hookah.
- C. Fife: DAN has now reported two cases of decompression sickness in divers less than 11 years old. What effect do bubbles have in the circulation around that growing epiphyseal plate? Has anybody looked at that?
- C. Lehner: Not to my knowledge. Our experiments have deliberately involved mature animals.
- R. Eckenhoff: We have found that age correlates best with the propensity to bubbles. There are few bubbles between 14 and 20. After about age 20, bubbles increase dramatically and then again probably at 60 or 70.
- R. Vann: This is also seen in marine crustaceans. Juveniles do not bubble whereas the adults do.
- S. Blair: Dr. Lehner showed a dramatic increase in DCS incidence in caisson workers after a 10 day strike. Over what period does resensitization occur?
- C. Lehner: From Dennis Walder's paper, it would seem there is some loss of adaptation over weekends.
- R. Vann: Yes. and a week to ten days for complete loss of adaptation.

## ASPECTS OF DIVE DATA: PRIMARY AND SECONDARY

**R.W. Hamilton**  
Hamilton Research, Ltd.  
80 Grove Street  
Tarrytown, NEW YORK 10591-4138 U.S.A.

*Other papers in this Workshop review several operational dive settings, including in particular the worlds of recreational, scientific and commercial diving. We are learning about dive computers and dive recorders, and are having a look at some aspects of diving and decompression physiology. In this session we address the nature of dive data and some things that can be done with it.*

### **Decompression Procedures are Based on Experience**

One thing that makes dive data particularly important in this technology area is the dependence of decompression and other diving techniques on prior experience. Decompression "models" or more properly computational algorithms are used for generating decompression tables. While these have been proven to be useful, there are limits to how well they emulate what really happens in the body during a decompression. For all of the models it is necessary to "calibrate" them or provide quantitative parameters for the algorithms in order to get them to produce a reliable output.

For some time the basic method of determining computational parameters applicable to humans has been to conduct laboratory exposures that try to emulate the conditions of the dive or exposure situation. Laboratory dive simulations performed in pressure chambers have worked well in the past, but they are not so useful in today's world. They have always been expensive, but now this approach suffers also from occasionally unreasonable liability and "human use" considerations. The biggest problem, however, is that at the current levels of decompression sickness (DCS) incidence an inordinate number of exposures is required to establish the performance of a table or procedure. Further, a case can be made that the only really meaningful dives are the real ones, performed in the water. There are other relevant decompression requirements, such as extravehicular activity performed from a spacecraft, tunnel and caisson work, and certain medical procedures. This situation begs the question, "Why not draw experience from actual field operations?"

### **Precision not as Important as Truth**

Before discussing options for decompression data, an important point about such data needs to be made. This is the issue of "precision" in measurement. For decompression exposure data it is not so important to measure pressures to the nearest centimeter of water or time to the nearest second as to be absolutely sure what actually happened. Because biological systems show such diversity or "fuzziness" there is a limit to the value of precision in measurement (Weathersby, Hart, *et al*, 1986).

A minimum requirement for decompression data is a valid pressure-gas-time profile. Other essential factors include identification and characterization of the individual and a description of the environmental conditions. It is also, of course, necessary to know the outcome of the exposure with respect to decompression sickness. Thus the important thing is to be sure that the profile recorded is

complete and the right one, that all factors are correctly identified, and that the outcome is properly checked and documented.

### **Primary and Secondary Data**

Data for generating decompression procedures can arbitrarily be divided into two classes, "primary" and "secondary." The word "data" is used here in the collective sense, and like "sheep" may refer to one or many.

#### **Primary data is from the laboratory.**

Primary data as classified here is of good enough quality that it can be used to "calibrate" predictive or analytical decompression computational models or algorithms. Requirements of such data include accurate measurements, but the primary benefit of the lab situation is careful observation and good documentation of the important variables. Significant in the matter of observation is that a trained observer is available to verify the absence of DCS or to note the details of any that may occur.

Another advantage of laboratory data is that the tested procedures can be planned to be most meaningful for the situation. This could include trials on a range of time-depth-gas combinations covering a set of tables, or exposures that test a critical element of a theoretical model.

Deficiencies in lab data include the fact that exposures may be dry or for conditions otherwise different from those of the ultimate application. The subjects may differ in their characteristics and motivations, and the perceived goals may be very different from those in field conditions.

#### **Secondary data is for quality control.**

Secondary data could be defined as the sort that might reveal the DCS incidence of a set of decompression tables in field use. The results might include dives not carried to the full time or depth of the table used (they rarely will be), and would surely involve a variety of subjects and conditions. However, assuming that the operating conditions are known this can lead to a valid assessment at the "quality control" level. Meticulous field data can also be used to assess operational considerations such as logistics, cost-effectiveness, etc.

It is important to note the distinction between laboratory data gathered under field conditions and operational data obtained where the objective is to get a job done, not just to get data.

### **Can Field Data be Useful as Primary Data?**

The question here is whether data obtained from field operations can be used as primary data. This seems possible if the data is of good enough quality.

#### **What information is needed?**

This is as has been listed above, (1) a profile, (2) details on the conditions of the exposure, and (3) the outcome with respect to DCS.

With all the talk about dive recorders, it is important to keep in mind that more data is needed than just the recorded time-pressure profile.

#### **Getting useful field data.**

Each time-pressure-gas profile of a diver followed by a decompression may be regarded as a dive "event." With this go the conditions and environment, and the results. It is important to identify the diver and link the log to the correct time and date. And when the data do get to the computer, an effective data base design needs to be able to handle all the important variables.

Getting enough data is a tradeoff. If the task is too imposing it can lead to nothing at all being done. An easy log tends to be filled out. A factor to be considered is that divers and dive crews tend to be "outdoor people" who may be in this career because they do not like paperwork. The trick here is to get people to care, to want to do it right; normally nobody cares.

Sorely needed and as yet without a good formula is a way of granting impunity for those who record the facts correctly in cases where someone has fouled up. Deviations from procedure may be recorded when there are no consequences, but if someone gets hurt it is a safe bet that the procedures noted in the log will look as if they had been copied directly from the manual. An early survey of some DCS data in the USN Safety Center can be interpreted that people will record deviations, but not if there DCS has occurred (Hunter *et al*).

#### **The pressure-gas-time profile .**

The profile, the basic exposure event, is the heart of the dive record, and it has to be correct to be of much value. Unfortunately, there are motivations to deviate. Among these are depth pay in the commercial world, and the macho image there and elsewhere. It may be easier to copy the table than record the real data. And there is always the tendency to avoid implication.

Dive recorders offer some help here, particularly with the details of the profile. They should store the pressure at about one minute intervals, using some sort of average rather than just the deepest point in the interval, and should also deal with fast changes. A useful recorder would go for a whole month. Recorders will be more welcome in commercial diving if they help both the supervisor and the diver. One type that does this is the on-line recorder that displays the current situation at the control station. Profilers, unfortunately, still do not make people honest.

#### **DCS reporting: A complex issue.**

A topic even more sticky than that of getting a good profile is to get good reporting of DCS. This depends only on the diver, and is highly influenced by motivational factors. Getting good DCS reporting on a "yes or no" level does not require a doctor, but of course a good neurological exam are needed; the details of diagnosis are important for other reasons than dive data. The new rules for diagnosis are welcome. (This paper refers to decompression sickness instead of decompression illness, excluding the embolism component as being not so relevant to dive data analysis.) "Type I" and "Type II" are good for selecting treatment, but do not say much about what has really happened. An important point is to ask tomorrow about yesterday's dive, since symptoms might occur after the log has been completed.

The difficult thing about DCS reporting is the impact it may have on a diver's career. This of course is most important to professional divers, but not even the casual recreational diver wants to be told he should give up diving. For a DCS reporting method to work has to be neutral to diver's career. There should be no incentive to fake it in either direction (e.g., a treatment should not generate a lot of overtime pay!), certainly no penalty for having it. This is not very true today.

One thing that seems to work is to make prompt reporting important. Early treatment benefits the diver, and tends to keep the record straight. Some companies are stressing both prompt and factual reporting, are making it important at all levels of management, and have reduced as much as possible the penalties to the diver for reporting. For example, he does not lose the next day's pay. It seems to be working.

One corollary point is the DCS should not be regarded as an accident. There are reasons for this. First, DCS is going to happen wherever there is diving. Also, DCS is not loss of control. Its occurrence is expected, there are means of dealing with it, and if treated promptly and properly at the end of the day there should be very few problems. Some events such as blowup, embolism, etc., are accidents of course.

### **Workshop on Operational Dive Data.**

Much talk at this Workshop has been about data bases and operational dive data. A little has been said about how this item has been used in the North Sea. To summarize briefly, Dr. Tom Shields analyzed some 25,000 commercial air dive logs, and found that most of the DCS was from dives in the zone of highest stress with respect to time and depth (Shields and Lee, 1988). The study also found that most (virtually all) of the high-stress dives were done using sur-D-O<sub>2</sub>, surface decompression with oxygen. Reacting to this, the Department of Energy tightly restricted effectively banning sur-D-O<sub>2</sub>, and recommended use of other techniques including in-water decompression. Later this was relaxed, then tightened again. The DEN restrictions have been criticized because the method was restricted, without recognition that these were the more stressful dives. There is more to this story, some of it reported in this Workshop, but an additional important point for us here is that it called attention to importance of operational data.

Some of these issues were addressed last August at a workshop on operational dive data held at the 1990 Joint Meeting in Amsterdam of the European Undersea Biomedical Society, the Undersea and Hyperbaric Medical Society, and the International Congress on Hyperbaric Medicine. A number of data bases operating with varying levels of success and their operators were reported. These include:

- Comex data base - Jean-Pierre Imbert (discussed here)
- Netherlands National Diving Center - Wouter Sterk
- UK Department of Energy (Robert Gordon's Institute of Technology - Tom Shields)
- HADES Project at Stolt-Nielsen Seaway Diving - Jan-Erik Jacobsen, Alf Brubakk
- IFEM-Ecosystems International Data System - C.J. Lambertsen
- Canadian Oil and Gas Lands Administration - Jan Merta, R.W. Hamilton
- CANDID/DCIEM (not for commercial, but good) - Ron Nishi
- USN Safety Center (not really for decompression)
- Some recreational diving data bases, mostly oriented toward DCS and accidents - outstanding among these is DAN

The Workshop had examples of and discussed many of the problems and some solutions, much of which is in the material given above. There was also an attempt to cover dive recorders. The most important result of that Workshop was that it started a dialogue on the subject, but it also showed the importance of data, emphasized means of making it valid, and reviewed the problems and approaches to solutions. As mentioned above, important remaining problems are impunity for reporting deviations, neutral career impact reporting of DCS, and how to deal with submaximal exposures in an analysis.

### **A Dive Database at UHMS**

The Undersea and Hyperbaric Medical Society has a 20+ year track record of good success in running an effective literature and abstract service and comprehensive, specialized library. The same mechanism could be an exchange medium for well screened decompression data. This has been advocated most strongly by Dr. R.D. Vann, with considerable interest and support from me and a few others.

Some problems with the concept are evident if it were to appear as a gigantic computer data base that could be all things to all people. No money to set it up has been identified, someone with the right skills and incentives has to run it, and we would need an incentive for depositors; we do not want a "deposit only" data bank.

However, a more modest system might work within the existing resources of the Society. This would, for the moment at least, handle disks of data in much the same manner as reprints are handled now. They would be described and cataloged, and could be distributed at a nominal cost. Data would

have to be complete, well screened and documented, and computer readable. It would not have to be in a uniform format as long as details were made available on what is there and what it means. To be most useful such data would need the pressure-gas-time profile, but dives done and tables used would be helpful in some cases, concentrating on the exposure as the entity. Some guidelines on this are needed.

There is an incentive to send in data. If a project performed on human volunteer subjects, particularly if it is done with public funds, produces useful profiles the investigator is obligated to get the maximum use out of the data, and I would think would be motivated to do so. Send in your data to UHMS.

#### References

- Hunter, W.L., G.B. Pope and D.A. Arsu. 1978. Decompression sickness and deep air diving. *Faceplate* 9(3): 7-9.
- Weathersby, P.K., B.L. Hart, E.T. Flynn and W.F. Walker. 1986. Human decompression trial in nitrogen-oxygen diving. NMRI 86-97. Bethesda, MD: Naval Medical Research Inst.
- Sterk, W. and R.W. Hamilton. 1991. Operational dive data workshop. Delft: Netherlands National Diving Center (in preparation).

## DESIGN OF MULTI-DEPTH DECOMPRESSION TABLES USING A MODEL OF TISSUE GAS BUBBLE DYNAMICS.

Michael L. Gernhardt  
C.J. Lambertsen  
R.G. Miller  
E. Hopkin  
and K. Guveyian  
Oceaneering Space Systems  
16920 Texas Ave C-9  
Webster, TEXAS 77598 U.S.A.

*Multi-depth decompression tables which provide bottom times of greater than 30 minutes at three or more depths from 0 to 180 ft., have been developed using an integrated decompression analysis system incorporating a model based on tissue gas bubble dynamics. The bubble dynamics model was evaluated by comparing the decompression stress predictions of the model to DCS observations in a variety of laboratory decompression trials, using the logistic regression method. The statistical analysis involved analyzing 6457 decompression exposures which resulted in 430 cases of DCS. The results of this analysis showed that the bubble dynamics model provided a statistically significant prediction of the occurrence of DCS ( $p \leq .05$ ) and an adequate fit of the DCS incidence data. The model predicted an increase in decompression stress with repetitive multi-day diving. Decompression schedules were then specifically designed to account for the decompression stresses associated with multi-week repetitive diving. These tables provide greater bottom time/decompression time ratios than conventional single depth diving or the "repet up" techniques.*

### Introduction

A large portion of commercial diving work is related to performing inspection, maintenance, and repair tasks at multiple depth elevations on offshore platforms. Existing U.S. Navy decompression procedures are designed for working at single depths with the total bottom time being applied to the deepest depth of the dive. Use of these procedures restricts diving operations to working at one platform elevation per dive.

A technique for working at multiple depths known as the "repet up" method has been adapted from the U.S. Navy repetitive dive tables by various commercial diving companies. This procedure involves using the repetitive dive group designations to link together a series of equivalent dives, without surface intervals, at progressively shallower depths into one dive. This technique is limiting in that it provides only short bottom times at each depth. Also, the shallowest depth for which an equivalent dive can be calculated is 40 fsw (feet sea water) and 70 fsw, for in-water decompression and surface decompression on oxygen, respectively, since these are the shallowest depth designations within the respective U.S.N. tables. These limitations reduce the decompression advantage that can be gained from working for long times at shallow depths at the end of a deeper multi-depth sequence.

Sport diving decompression computers are not applicable to commercial diving operations. Most of these computers utilize modified Haldane/Workman decompression algorithms which have been

shown to be progressively less effective at controlling decompression stresses from longer and deeper commercial dives (Shields and Lee, 1986). These computers are designed to calculate in water decompression schedules, whereas commercial diving operations primarily utilize surface decompression on oxygen. Another problem with decompression computers is imposing limits that restrict operational exposures to within the tested limits of the decompression model.

Decompression tables allow limits to be defined and then tested to ensure confidence of a low DCS risk. Should unplanned events force exposures outside the tested limits, then conservative emergency decompression procedures can be provided.

Multiple working depth decompression tables for commercial diving were developed in 1980 (Gernhardt) using the Haldane/Workman model and in 1985 using a tissue gas bubble dynamics model (Gernhardt, *et al.*). Some of the issues involved in calculating these tables include:

- Use of an appropriate model of decompression stress.
- Ensuring that there are acceptable levels of decompression stress at the shallowest working depth, based on the worst case combination of deeper depths and bottom times.
- Providing sufficient depth/time combinations to allow continuous operations throughout the air diving range.
- Providing a simple format for selecting the proper decompression schedules.

#### Decompression Stress Model

Commercial diving decompression experience (Solus Ocean Systems) suggested that extrapolating the Haldane/Workman model to long duration multi-depth exposures would not be reliable. For this reason, a decompression model based on tissue bubble dynamics was used in conjunction with the Haldane/Workman model.

#### Conceptual Formulation of the Bubble Dynamics Model

The conceptual formulation of the bubble dynamics model assumes that DCS is not a localized threshold phenomena that always occurs when some critical value of decompression stress is exceeded.

The observations that decompression can result in a spectrum of different symptoms which can occur at different sites in the body with different degrees of severity suggests that DCS is a generalized systemic phenomena of graded degrees (Lambertsen, 1989). Specific symptoms of DCS would be local expressions of generalized DCS. There are also likely to be other forms of asymptomatic DCS that can occur at multiple sites and go unrecognized because the degree of gas phase separation and expansion is not severe enough to elicit detectable symptoms at a particular anatomical site (Lambertsen, 1989).

Since the specific tissue types and sites which result in the spectrum of DCS symptoms are not known with certainty, then the physical, physiological and biochemical parameters of those tissue sites can not be precisely defined (Lambertsen, 1989).

Given these limitations, it is not practical to model decompression stresses at specific anatomical sites. It is also not sensible to assume that there is one worst case theoretical tissue site that would apply to all types of decompression and at all points in a decompression profile (Lambertsen, 1989). Instead, it is more reasonable to model decompression stress as a generalized systemic phenomena resulting from gas phase separation and growth of multiple degrees and at multiple sites.



This is accomplished by modeling the growth of a single theoretical bubble, resulting from an assumed nucleus in each of a spectrum of tissue compartments which collectively provide an adequate description of the whole body inert gas exchange. Prediction of gas phase growth and resolution is accomplished within an integrated system of tissue gas exchange, bubble dynamics and oxygen effect (Lambertsen, *et al.* 1991). The highest level of decompression stress (determined by the largest theoretical bubble) occurring in the spectrum of tissue compartments can then be used as a "worst case" general description of the levels of decompression stress resulting from the much more complicated and interrelated physical, physiological and biochemical phenomena which produce DCS symptoms.

### Assumptions of the Model

The specific assumptions of the bubble dynamics model are as follows:

1. Gas bubbles are the initial cause of DCS symptoms.
2. Gas nuclei are assumed to exist or form normally in tissues during decompression.
3. Gas bubbles grow prior to symptoms of DCS.
4. The inert gas exchange between a well stirred tissue and a free gas bubble is limited by diffusion through a diffusion barrier.
5. The inert gas exchanges between the lungs and the tissues can be described with a multi-compartment exponential inert gas exchange model.
6. The volume of gas in an extravascular bubble is much smaller than the volume of gas dissolved in the tissues and initial pre-DCS bubble growth does not appreciably lower tissue inert gas tensions.
7. There is a worst case tissue for defining maximum decompression stress, but the specific tissue type depends on the dive profile and type of exposure.

The detailed rationale and supporting data for these assumptions and the mathematical derivation of the model are beyond the scope of this paper (Gernhardt, 1991; Lambertsen, 1989).

A graphic illustration of the bubble dynamics model is shown in Figure 1.

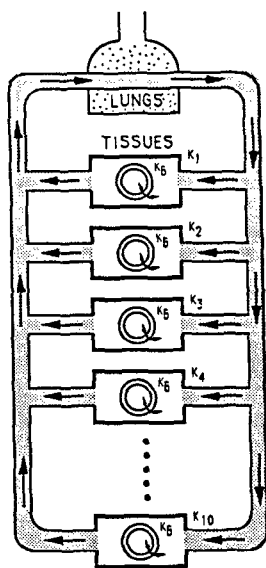

Figure 1. Bubble Dynamics Model. The generalized systemic phenomena of decompression stress and DCS is modeled by predicting the theoretical bubble growth, in each of a spectrum of hypothetical tissue compartments which collectively describe whole body inert gas exchange. The highest level of decompression stress, defined by the maximum bubble growth, is then used to provide a general prediction of the levels of decompression stress resulting from the more complicated interrelated physical, physiological and biochemical phenomena that produce detectable symptoms of DCS.

### Evaluation of the Model

The bubble dynamics model was evaluated by comparing the decompression stress predictions of the model to DCS observations in a variety of laboratory decompression trials (Gernhardt, 1991; Lambertsen, *et al.*, 1991) using the logistic regression method (Lee, 1980). The statistical analysis involved analyzing 6457 decompression exposures which resulted in 430 cases of DCS. The decompression data (provided by the International Diving, Hyperbaric Therapy and Aerospace Data Center) included a wide range of decompression techniques (Table 1).

**Table 1. Summary of laboratory decompression data**

Decompression Procedure	Man Trials	DCS
No Stop Ascent	674	52
Submarine Escape	299	4
Air Decompression In-Water	2,687	133
N <sub>2</sub> - O <sub>2</sub> Decompression	488	33
O <sub>2</sub> Decompression "In-Water"	301	8
Surface Decompression		
With Oxygen	1,733	156
With Air	275	44
<b>Total Numbers</b>	<b>6,457</b>	<b>430</b>

Data sets were combined based on the likelihood ratio test (Lee, 1980). Since some of the data sets were small, or did not have a wide range of decompression stress, the judgement was made to combine data sets even though the likelihood ratio test criterion was not met.

The results of the statistical analysis are shown below in Table 2.

**Table 2. Summary of statistical analysis of nitrogen based decompression data (Lambertsen, Gernhardt, *et al.*).**

Data Set: Combined Decompression Data from Nitrogen Based Diving		Test for Improvement		Test for Goodness of Fit	
Index	Log-Likelihood	$\chi^2$	p-value	$\chi^2$	p-value/df
Null Set	-1506				
Bubble Growth Index	-1412	187.9	0.000	10.4	0.24/8

The DCS incidence data associated with different degrees of theoretical bubble growth were plotted as a histogram. The x-axis denotes the bubble growth index (the maximum bubble radius in any tissue compartment divided by the initial radius) and the y-axis the associated DCS incidence. The number of man dives associated with each interval is shown at the top of each bar. This is one of a series of analytical histograms derived by and with the International Diving, Hyperbaric Therapy and Aerospace Data Center (Lambertsen, 1991).

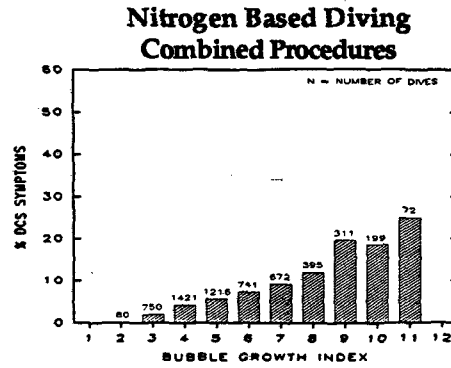

**Figure 2. Bubble Growth Index vs. DCS incidence for combined nitrogen based decompression data (Lambertsen, et al. 1991, Gernhardt 1991).**

The results of the statistical analysis showed that the bubble dynamics model provided a statistically significant prediction of the occurrence of DCS ( $p \leq .05$ ) and an adequate fit of the DCS incidence data ( $p \geq .05$ ).

#### Comparison of Bubble Growth Predictions for Singular Depth and Multi-Depth Diving.

Multiple working depth decompression tables were calculated based on the bubble dynamics model (Gernhardt, 1985). Figure 3 shows the theoretical bubble growth associated with a single depth dive to 160' FSW for 40 minutes using the U.S. Navy SUR-D-O2 Tables.

**Figure 3. Single depth dive. Theoretical bubble growth associated with a single depth dive to 160'/40 min using the U.S.N. Sur-D-O2 decompression tables.**

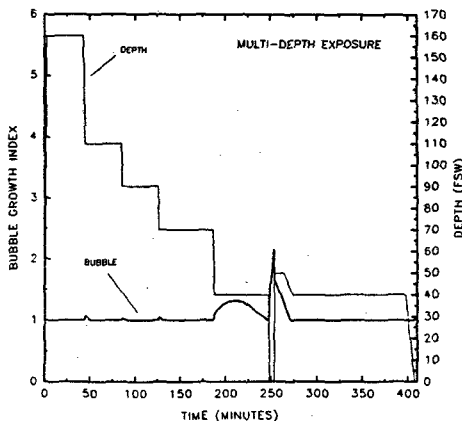
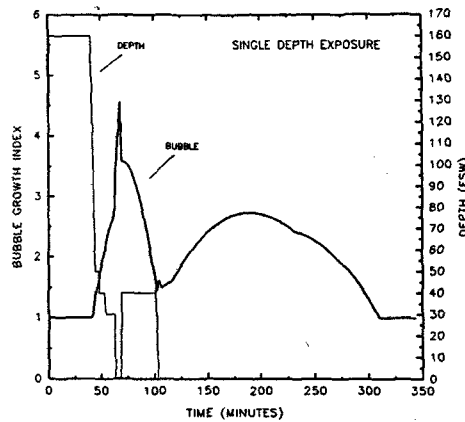

**Figure 4. Multi-depth dive. The theoretical bubble growth associated with a dive to 160'/40 minutes, 110'/40 minutes, 90'/40 minutes, 70'/60 minutes, and 40'/60 minutes followed by surface decompression on oxygen.**

Figure 4 shows the theoretical bubble growth associated with a dive to 160'/40 min., 110'/40 min., 90'/40 min., 70'/60 min., and 40'/60 min. followed by surface decompression using the multi-depth decompression tables.

### Multi-day Diving

The multi-depth tables were designed to control decompression stresses to the levels defined through other tested decompression procedures which were found to produce a low risk of DCS in operational use. Additional analysis of operational diving records suggested that there was an increased DCS risk associated with repetitive multi-day diving.

Figure 5 shows the theoretical bubble growth associated with the same multi-depth dive and decompression performed for five days with a 12 hour surface interval between dives. The bubble dynamics model predicted the same dive performed repetitively would result in increased decompression stress on successive days. For this reason, modifications were made to the decompression procedures to account for the increased decompression stress associated with multi-week diving.

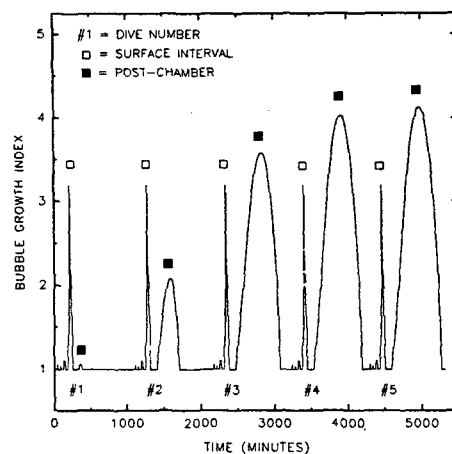

Figure 5. Prediction of increased decompression stress associated with repetitive multi-depth diving using surface decompression on oxygen.

### Operational Efficiency

The efficiency of the multi-depth decompression tables should be much greater than equivalent single depth procedures, or the "repet up" technique. For the example of the 160 FSW dive, the single depth procedure provided 40 minutes of bottom time against a decompression time of 61 minutes. This results in a work efficiency index (bottom time/decompression time) of approximately .64. The multi-depth dive results in a work efficiency index of 1.74 (240 minutes bottom time/138 minutes decompression). The "repet up" technique, depending on the exact profile used, would provide a work efficiency index of approximately .8 to 1.0.

### Design of the Multi-Depth Tables for Practical Operational Use

Multi-depth tables must provide multiple time options at multiple depths across the air diving range. After the deepest working depth, the time spent at shallower depths must be specifically accounted for in the decompression schedule.

The total number of decompression profiles which must be generated to describe all possible combinations of times and depths would be equal to the number of time options raised to the power of the number of depth options.

**Table 3. Series of multiple working depth decompression tables with the associated working depth ranges and bottom time options (Gernhardt, et al., 1985).**

DEPTH SERIES	WORKING DEPTH RANGES (FSW) BOTTOM TIME OPTIONS/LIMITS (MINUTES)				
	<u>180-161 - 1D</u>	<u>120-101 - 1D</u>	<u>100-81 - 1D</u>	<u>80-61 - 1D</u>	<u>60-40 - 1D</u>
180	10 1	0 0	0 0	0 0	0 0
	20 2	10 1	10 1	10 1	10 1
	30 3	20 2	20 2	20 2	20 2
	40 4	40 4	40 4	40 4	30 3
					40 4
				60 6	
160	<u>160-141 - 1D</u>	<u>110-91 - 1D</u>	<u>90-71 - 1D</u>	<u>70-51 - 1D</u>	<u>50-40 - 1D</u>
	10 1	0 0	0 0	0 0	0 0
	20 2	10 1	10 1	10 1	10 1
	30 3	20 2	20 2	20 2	20 2
	40 4	40 4	40 4	40 4	30 3
			60 6	40 4	
				60 6	
140	<u>140-121 - 1D</u>	<u>100-81 - 1D</u>	<u>80-61 - 1D</u>	<u>60-40 - 1D</u>	
	10 0	0 0	0 0	0 0	
	20 2	10 1	10 1	10 1	
	30 3	20 2	20 2	20 2	
	40 4	40 4	40 4	30 3	
	50 5	50 5	40 4		
			60 6		
120	<u>120-101 - 1D</u>	<u>90-71 - 1D</u>	<u>70-51 - 1D</u>	<u>50-30 - 1D</u>	
	10 1	0 0	0 0	0 0	
	20 2	10 1	10 1	10 1	
	30 3	20 2	20 2	20 2	
	40 4	40 4	40 4	30 3	
	50 5	60 6	40 4		
			60 6		
100	<u>100-81 - 1D</u>	<u>70-51 - 1D</u>	<u>50-31 - 1D</u>	<u>30-20 - 1D</u>	
	10 1	0 0	0 0	0 0	
	20 2	10 1	10 1	10 1	
	30 3	20 2	20 2	20 2	
	40 4	40 4	40 4	30 3	
	50 5	60 6	40 4		
			60 6		
80	<u>80-71 - 1D</u>	<u>60-41 - 1D</u>	<u>40-21 - 1D</u>		
	10 0	0 0	0 0		
	20 2	10 1	10 1		
	30 3	20 2	20 2		
	40 4	40 4	30 3		
	60 6	40 4			
		60 6			
70	<u>70-60 - 1D</u>	<u>50-31 - 1D</u>	<u>30-20 - 1D</u>		
	10 0	0 0	0 0		
	20 2	10 1	10 1		
	30 3	20 2	20 2		
	40 4	40 4	30 3		
	60 6	40 4			
	80 8	60 6			
	100 X	80 8			
		100 X			
60	<u>60-41 - 1D</u>	<u>40-21 - 1D</u>	<u>20-10 - 1D</u>		
	10 1	0 0	0 0		
	20 2	10 1	10 1		
	30 3	20 2	20 2		
	40 4	40 4	30 3		
	60 6	40 4			
	80 8	60 6			
	100 X	80 8			
		100 X			
			80 8		
			100 X		

If four time options (i.e. 10, 20, 30, and 40 min.) were provided at ten foot depth intervals from 0 to 180 FSW, then  $6.87 \times 10^{10}$  profiles would have to be generated to cover all possible time/depth combinations. Additionally, a zero time option must be provided for each depth in case no work was planned at that depth, or it became necessary to abort the dive in the middle of the multi-depth sequence.

The total number of decompression schedules was reduced to practical numbers by developing a series of eight different multi-depth tables with the deepest depth of the dive defining the table series. Since divers seldom maintain precise depths, the depth options were defined as 20 FSW depth ranges within which the diver could work. Table 3 shows the eight different tables along with the multiple working depth ranges and bottom time options. This approach provides complete coverage of the 0-180 FSW depth range with approximately 7000 decompression schedules.

### Selecting the Decompression Schedule

The appropriate decompression schedule is selected by combining the I.D. numbers for each depth range and time option into a sequence. For the example of a dive to 160'/40 min., 110'/40 min., 90'/40 min., 70'/60 min., and 40'/60 min. the decompression schedule number would be 44466. The decompression schedules are arranged in increasing numerical order providing a simple means to select the proper schedule.

The individual decompression schedules were all calculated based on the worst case dive profile within the multi-depth/time sequence. Since it is unlikely that a diver would ever work at exactly the worst case profile, the table design has built in safety factors that should lower the DCS risk.

### Conclusions

The multi-depth decompression tables (Gernhardt, *et al.* 1980, 1985) were specifically designed to provide long bottom times at multiple depths for repetitive multi-week diving. The decompression stress model on which these tables were based has demonstrated that it provides a good prediction ( $p \leq .05$ ) and fit of a wide range of DCS incidence data (Lambertsen, 1991; Gernhardt, *et al.* 1991). The table design is operational, practical and introduces safety factors which should further reduce the risk of DCS.

These tables should provide both safer and more efficient decompression procedures than existing tables or commercially available decompression computers, for specific commercial diving operations that require work at multiple elevations on offshore platforms. The integrated decompression stress model and table design techniques can be adapted to dives which involve intermittent exposures between depths. This adaptation might also be useful for specific scientific or military diving operations.

### References

- Conkin, J., B.F. Edwards, J.M. Waligora, and D.J. Horrigan, Jr. 1987. Empirical Models for use in Designing Decompression Procedures for Space Operations. NASA Technical Memorandum 100456. NASA/JSC, Houston, TX.
- Eckenhoff, R.G. and J.W. Parker. 1984. Latency in the onset of decompression sickness on direct ascent from air saturation. *J. Appl Physiol: Respir. Environ Exercise Physiol.*, 56, pp. 1070-1075.
- Gernhardt, M.L. 1980. Multiple depth decompression tables for commercial diving. IFEM - technical report, Institute for Environmental Medicine.
- Gernhardt, M.L. 1982. Design of Decompression Procedures from multi-depth exposures. MS Thesis, University of Pennsylvania.

- Gernhardt, M.L. 1985. Tissue Gas Bubble Dynamics During Hypobaric Exposures. SAE Technical Paper Series. Fifteenth Intersociety Conference on Environmental Systems.
- Gernhardt, M.L. 1988. Mathematical Modelling of Tissue Bubble dynamics During Decompression. *Advances in Underwater Technology, OceanScience and Offshore Engineering, Volume 14: Submersible Technology.* Society for Underwater Technology (Graham and Trotman).
- Gernhardt, M.L., C.J. Lambertsen, R.G. Miller, E. Hopkin. 1990. Evaluation of a decompression model based on tissue bubble dynamics. Joint Meeting on Diving and Hyperbaric Medicine. Sponsored by EUBS and UHMS, Amsterdam.
- Gernhardt, M.L., C.J. Lambertsen, R.G. Miller, E. Hopkin and K. Guveyian 1985. Multi-depth decompression tables. *Oceaneering Int./Ecosystems diving procedures manual.*
- Gernhardt, M.L. 1991. Development and evaluation of a decompression stress index based on tissue bubble dynamics. Ph.D. dissertation. University of Pennsylvania.
- Horrigan, D.J.Jr., J.M. Waligora, J. Gilbert, B. Edwards, J. Conkin, and J. Stanford. 1989. Decompression in Space. *In: The Physiological Basis of Decompression Thirty-Eighth Undersea and Hyperbaric Medical Society Workshop.* pp. 425-437.
- Lambertsen, C.J. 1967. Basic requirements for improving diving depth and decompression tolerance. *In: Proc. 3rd Symp. Underwater Physiology.* Ed. by C.J. Lambertsen. Williams and Wilkins, Baltimore, pp. 223-240.
- Lambertsen, C.J. 1989. Relations of isobaric gas counterdiffusion and decompression gas lesion diseases. *The Physiological Basis of Decompression.* Vann, R.D., Ed. UHMS Publ 75 (Phys) 6/1/89. Bethesda, Undersea and Hyperbaric Medical Society, pp. 87-103.
- Lambertsen, C.J., M.L. Gernhardt, R.G. Miller and E. Hopkin. 1991. Development of decompression procedures - based upon integrated analytic models of tissue gas bubble dynamics and oxygen tolerance. *Ecosystems/Ocean Systems Engineering Summary Report 7/1/91.* International Diving, Hyperbaric Therapy and Aerospace Data Center, Institute for Environmental Medicine, Philadelphia.
- Lambertsen, C.J. 1991. The International Diving, Hyperbaric Therapy and Aerospace Data Center. *In: Operational Dive and Decompression Data:Collection and Analysis.* W. Sterk and R.W. Hamilton. (Eds.) European Undersea Biomedical Society Publication 17-8-90. Foundation for Hyperbaric Medicine, Amsterdam.
- Lee, E.T. 1980. *Statistical Methods for Survival Data Analysis.* Lifetime Learning publications. Belmont Cal. pp. 355-364.
- Shields, T.G., P.M. Duff, and S.E. Wilcock. 1989. Decompression Sickness from Commercial Offshore Air-Diving Operations on the U.K. Continental Shelf During 1982 to 1988. Report produced for Department of Energy under Contract #TA/93/22/249. Aberdeen: Robert Gordon's Institute of Technology.
- Shields, T.G., and W.B. Lee. 1986. The Incidence of Decompression Sickness Arising from Commercial Offshore Air Diving Operations in the UK Sector of the North Sea During 1982/83. Aberdeen: Robert Gordon's Institute of Technology.
- Solus Ocean Systems, Operational Diving Records. 1981-1983. Component data base of International Diving, Hyperbaric Therapy and Aerospace Data Center.

Shreiner, H.R., and P.L. Kelley. 1967. Computation methods for decompression from deep dives. *In: Proc. 3rd Symp. Underwater Physiology.* Ed. by C.J. Lambertsen. Williams and Wilkins, Baltimore, pp. 277-299.

Waligora, J.M., D.J. Horrigan, and J. Conkin. 1987. The effect of extended oxygen prebreathing on altitude decompression sickness and venous gas emboli. *Aviat. Space Environ. Med.*, 58A, pp. 110-112.



## QUASI-PHYSIOLOGICAL DECOMPRESSION SICKNESS INCIDENCE MODELING

Wayne A. Gerth  
Richard D. Vann  
David G. Southerland

Department of Anesthesiology  
F.G. Hall Hypo- Hyperbaric Center  
Duke University Medical Center  
Durham, NORTH CAROLINA 27710 U.S.A.

*The risk of decompression sickness (DCS) in repetitive diving inevitably limits the safely allowable depths and bottom times, or requires prolongation of surface intervals between dives. Bottom time extensions and surface interval decreases that are theoretically afforded by breathing oxygen-enriched air, or nitrox, at depth and 100% oxygen at surface were quantitatively assessed through a modeling effort based on maximum likelihood. The model was founded on the assumption that DCS is caused by tissue gas bubble formation that is governed in turn by the kinetics of gas exchange between tissue and blood and between tissue and bubbles. Diver susceptibility to the bubbles and the corresponding probability of DCS was postulated to increase with bubble volume according to a log-normal statistical distribution. Maximum likelihood techniques were used to optimize model parameter values about actual DCS incidence data for a wide variety of dive profiles. The parameterized model was then used to estimate the bottom time maxima and surface interval minima in hypothetical repetitive dive profiles performed with and without nitrox breathing at depth and 100% oxygen breathing during the surface intervals. Results illustrate that the judicious use of oxygen-enriched breathing media can allow substantially longer bottom times and shorter surface intervals, with no increases in attendant risks of DCS, than those allowable with air breathing alone.*

### Introduction

The risk of decompression sickness (DCS) increases with the dive depths, the dive bottom times and the number of dives in a repetitive dive schedule. This increasing risk inevitably limits the safely allowable depths and bottom times, or requires prolongation of surface intervals between dives. During repetitive dives to given depths, however, the rate of this risk accumulation can be slowed through the judicious use of oxygen to allow safely prolonged bottom times, reduced surface interval times or both. Such outcomes are achieved because the breathing of oxygen-enriched air (nitrox) at pressure reduces nitrogen uptake during a dive (Hamilton, *et al.*, 1989), while breathing 100% oxygen at surface accelerates the elimination of nitrogen from the body after a dive. Each effect reduces the probabilities of bubble formation and DCS after the dives.

While these principles are easily stated, their rendering to actual practice is a substantial challenge. A method is required that integrates the cumulative effects of successive repetitive dives and enables depth/time profiles to be computed precisely according to various levels of acceptable DCS risk. The method must be sufficiently flexible to interpolate and extrapolate into depth/respired gas/time regions that are not covered by present decompression tables; should enable computation of

safe diving profiles on a continuous basis in environments where real-time data are available, and; should provide measures of the statistical confidence that can be taken in its predictions. Finally, the method should be able to provide improved predictions by being able to "learn" from experience as it accumulates.

We outline a method that we have developed at Duke University that incorporates all of these features. Theoretical results provide quantitative indications of how nitrox and surface interval oxygen can increase bottom times and reduce surface interval times in repetitive diving. The protocol and preliminary results of man-dive series that we are presently running to test the method and its predictions are described in a separate report (Fawcett, *et al.*, 1991).

## Methods

### Model Structure

The method is based on the assumption that DCS is a probabilistic phenomenon. This requires that the probability of any given decompression outcome,  $P(\text{outcome})$ , which is defined as the sum of the probabilities of all possible outcomes, be unity:

$$P(\text{outcome}) = \sum_{i=0}^{(m-1)} P(i) = 1 \quad (1)$$

where  $P(i)$  is the probability of each of  $m$  possible outcomes. In order to simplify the analyses, DCS is considered to be a binary event that either occurs or does not occur in any given decompression profile. Equation (1) then becomes:

$$P(\text{outcome}) = P(0) + P(1) = 1 \quad (2)$$

where  $P(1)$  = probability of DCS, and;  $P(0)$  = probability of no DCS =  $1 - P(1)$ .

The probability of DCS after any given decompression is then assumed to be some function,  $f$ , of various environmental and physiological effectors;  $x_1, x_2, x_3, \dots, x_j$ ; that are characteristic of the decompression:

$$P(\text{DCS}) = P(1) = f(x_1, x_2, x_3, \dots, x_j) \quad (3)$$

For example, depth, time at depth and respired gas composition were used in the present analyses, but are only a few of the possible effectors that could be considered.

Exact forms of the function  $f$  were developed by assuming that the probability of DCS in a given dive profile  $P(\text{DCS})$  can be expressed as a logistic equation of the following general form:

$$P(\text{DCS}) = 1 / (1 + e^z) \quad (4)$$

where

$$z = \eta [\ln(\text{ED}_{50}) - \ln(D)] \quad (5)$$

As shown in Eq. (5), the argument of the exponent,  $z$ , is a function of the parameter  $\eta$ , a dose  $D$  which is a measure of the decompression stress that causes DCS, and the  $\text{ED}_{50}$ . The latter is the value of the dose at which 50% of the diving population develops DCS.

After substitution of Eq. (5), Eq. (4) is readily transformed into the perhaps more familiar Hill equation:

$$P(\text{DCS}) = D^\eta / (D^\eta + ED_{50}^\eta) \quad (6)$$

where the  $\eta$ , the  $ED_{50}$  and the parameters  $\beta_k$  in the function  $D = g(x_1, x_2, x_3, \dots, x_i)$  can be adjusted to fit the model to experience.

An essential feature of this formulation is that a given decompression profile is postulated to produce a certain stress or dose  $D$  to which the diving population is sensitive according to a nonuniform or sigmoid distribution. The dose is given by another function,  $g$ , that embodies the dependence of the DCS probability on the hypothesized environmental and physiological effectors. This could be one of any number of different functions that incorporate particular notions of what constitutes decompression stress in a given decompression profile. We chose to proceed from the well-accepted idea that DCS is caused by gas bubble growth that is caused in turn by decompression-induced gas-supersaturation. We further postulated that the probability of DCS at any point in a dive profile is a function of the bubble volume prevailing at that time.

In order to compute bubble volume, a quasi-physiological model of perfusion-limited gas exchange in a number of parallel-perfused tissue compartments was developed as schematized in Figure 1. Arterial gas was assumed always equilibrated with alveolar gas as given by the alveolar gas equation. Gas exchange between tissue and blood in each compartment  $i$  was governed by the gas solubility in blood ( $\alpha_b$ ) and by the compartment-specific gas solubility ( $\alpha_{t,i}$ ), blood flow ( $Q_i$ ) and compartmental volume ( $V_{t,i}$ ). With decompressions sufficient to produce gas-supersaturation in any compartment, a bubble grew in the compartment by diffusion-limited exsolution of gas from its well-stirred surroundings. Subsequent compression caused the bubble to dissolve with the same kinetic constraints.

Through neglect of the effects of volume dependent changes in bubble surface area, bubble surface pressure and bubble interfacial permeability, the equations describing bubble growth and resolution could be solved analytically as functions of depth, inspired oxygen fraction and time at depth to obtain bubble volume at any given time in a profile. Thus, each bubble was modeled essentially as a volume of gas separated from its tissue by two parallel interfacial planes of infinite extent, with the diffusion barrier between bubble and tissue in each compartment characterized by a scalar permeability,  $K_i$ . The  $\alpha_b Q_i$ ,  $(\alpha V)_{t,i}$ , and  $K_i$  constituted the adjustable  $\beta_k$  in the model function for  $D$  in Equations (5) and (6). Because the time of DCS onset is usually missing from available data, the decompression dose was taken as the largest volume attained by any bubble in any of the compartments during the last profile stage at surface. As a result, only a single compartment governed the outcome of any given dive, despite the number of tissue compartments actually parameterized.

Each dive profile to be processed was encoded as a sequence of stages, with each stage characterized by a constant pressure or depth, a respired  $O_2$  fraction and a time at stage. The model was then exercised on the profile by sequentially processing these stages, preserving the model state at the end of each stage as the initial state for the next. With sufficiently high values of the  $K_i$ , the model showed behavior similar to that of the so-called Exponential-Linear model described by Thalmann (1986).

It is important to note that at this point in its description, the model is a theoretical construct that provides only a framework for the processes that underlie development of a decompression dose and its associated DCS probability. Relationships between various parameters are formalized into algebraic and logical expressions, but actual values of the parameters remain unspecified.

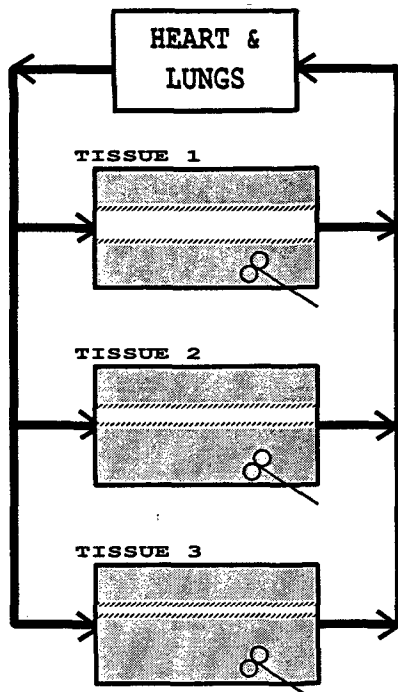

Figure 1. Schematic of the Bubble Dose Model. Bubble volume in each of a number of tissue compartments was governed by modeled kinetics of gas exchange between blood, tissue and bubble. The growth and resolution of each bubble were limited by a diffusion barrier between the bubble and its well-stirred surroundings. By considering the bubble to have no surface curvature, its volume could be computed analytically as a function of the depth, inspired O<sub>2</sub> and time throughout a dive profile. The bubble dose used to compute the probability of DCS for a given dive profile was taken as the largest of the maximum bubble volumes attained by the bubbles in all the compartments during the last stage at surface.

### Model Parameterization

The problem of model parameterization was solved by using the method of maximum likelihood (Weathersby, *et al.*, 1984). This method provides a means to find parameter values for a given model from actual experience. In so doing, it forces theory into best conformance with available data and provides quantitative measures of how well the data are described by the model for comparison of model performance to that of other models.

Similar to the definition of the individual outcome probability, the likelihood,  $l_i$ , of an individual decompression,  $i$ , is defined as the product of the probabilities of possible outcomes. Additionally, however, the contribution of each probability is conditioned by actual experience through the influence of an outcome variable,  $\chi$ . Thus, the definition of the likelihood under the present constraints, where DCS either does or does not occur, is given by:

$$l_i = P_i(1)^\chi * P_i(0)^{(1-\chi)} \quad (7)$$

where  $\chi = 0$  if DCS does not occur in the exposure and  $\chi = 1$  if DCS occurs. In turn, the likelihood,  $L$ , of a series of  $n$  decompressions is the product of the individual likelihoods:

$$L = \prod_{i=1}^n l_i \quad (8)$$

The likelihood for any given model about a data set of  $n$  dives is computed as shown in Equation (9), after the theoretical algorithm giving the probability  $P(1)$  [ $=P(\text{DCS})$ ] is substituted:

$$L = \prod_{i=1}^n l_i = \prod_{i=1}^n (P_i(1)^\chi * [1 - P_i(1)]^{(1-\chi)}) \quad (9)$$

A given set of model parameter values therefore yields a likelihood value that quantitatively embodies information from both theory (the model structure) and experience (the model parameters).

Importantly, as a measure of how well the data set is correlated by the model, the likelihood is largest when the parameterized model best correlates the data. "Best fit" or optimized parameters for a model are consequently found by using an algorithm that systematically adjusts the parameter values until the likelihood is maximized. An iterative nonlinear parameter estimation routine based on Marquardt's algorithm (Marquardt, 1963; Homer and Bailey, 1977) was used for these purposes. In order to ensure that parameters giving the global maximum likelihood were obtained, each of a series of separate optimizations were run from different sets of starting parameter values. The latter were obtained by systematic perturbation of those in the user-specified starting set.

Once found through the fitting procedure, the optimized parameters can be used in the model to compute DCS risk profiles for arbitrary pressure/ respired gas/time profiles, or conversely, to schedule decompressions so that a given user-specified DCS risk is achieved but never exceeded. Algorithms have been developed to: a) calculate bottom time maxima in no-stop single or repetitive dive profiles with given surface interval properties; b) compute the staging required to bring a diver to surface when a no-stop limit has been exceeded, and; c) calculate surface interval minima in repetitive dive profiles with given depth stage properties.

## Results and Discussion

### Model Optimization

The adjustable parameters in a two-compartment bubble model; the Hill exponent  $\eta$ , the  $ED_{50}$  and the  $\beta_L$  were optimized about a data set consisting of 3249 man-exposures in 247 different dive profiles and their corresponding DCS incidences. The sources from which the data set was compiled are listed in Table I.

Table I. Dataset Description

Source	# Profiles	Total # Man-dives	DCS incidence(%)
Thalmann, 1986	49	837	5.85
Nishi, <i>et al.</i> , 1982	25	185	1.08
Nishi, <i>et al.</i> , 1984	22	255	5.10
Lauckner, <i>et al.</i> , 1984a	14	132	0.0
Lauckner, <i>et al.</i> , 1984b	9	109	6.42
Weathersby, 1986	47	477	7.58
Thalmann, 1980	24	445	5.39
Thalmann, 1984	23	228	4.82
Rogers, 1991	27	462	0.0
Fawcett, <i>et al.</i> , 1991	7	119	0.84
Total	247	3249	4.25

The "goodness of fit" of the bubble model was evaluated by comparing its likelihood about the data set to the likelihoods of the null and perfect models. The perfect model likelihood is that given when each exposure in the data set is assigned a probability equal to the observed DCS incidence for that exposure. In contrast, the null model likelihood is that obtained when the probability for each exposure is assigned the same value equal to the mean DCS incidence for the entire data set. The logarithms of these likelihoods for the present data set and model are shown in Table II. While the

likelihood of the bubble model falls well below that of the perfect model, indicating wide latitude for improvement, it is above that of the null model. Using the likelihood ratio test and Chi-squared distribution (Weathersby, *et al.*, 1984), this latter difference was found to be significant at  $p < 0.000001$ . The fitted bubble model consequently reproduces essential behavior embodied in the data set.

**Table II. Log Likelihoods of the Dataset and Fitted Bubble Model.**

Model	Log Likelihood
Perfect	-375.829
Bubble	-543.370
Null	-570.948

**Model Exercise**

"Iso-risk" profiles calculated using the fitted bubble model in the algorithms for bottom time maximization and surface interval minimization illustrate the theoretical advantages of using nitrox breathing at depth and 100% oxygen breathing during the surface intervals in repetitive dive profiles. Consider, for example, a series of model exercises in which bottom times in a schedule of three no-stop repetitive dives to 80 fsw are maximized under constraint of a 2.0% maximum DCS probability, while the surface intervals are kept fixed at 65 min duration. Only the gases breathed by the hypothetical diver are changed from one exercise to another.

Figure 2 shows the schedule, with its corresponding DCS probability time profile, calculated when air is breathed throughout. Each dive is followed by a period at surface during which the probability of DCS rises from zero to attain a maximum of 2.0%. This time-increasing probability occurs because the tissue that emerged to govern the outcome of this decompression has relatively fast gas exchange kinetics (half-time = 109 min), but hosts a bubble whose growth and resolution are limited by a significant barrier to diffusion between bubble and tissue. The sum of the bottom times for the three dives in this schedule is 48 min.

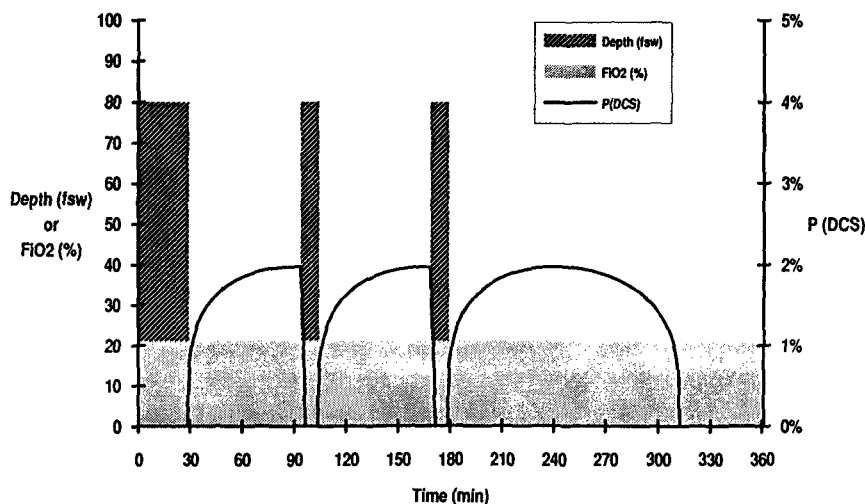

**Figure 2. Computed repetitive dive schedule and corresponding DCS probability profile for three no-stop dives to 80 fsw performed with air breathing throughout. Dive bottom times were adjusted so that each decompression produced a 2.0% probability of DCS. Surface intervals between these "iso-risk" dives were each fixed at 65 min duration.**

The computed 2.0% iso-risk schedule and PDCS profile for the same three dives performed with nitrox (36% O<sub>2</sub>; balance N<sub>2</sub>) as the respired gas during each of the dives is shown in Figure 3. As in the first exercise, air is breathed at surface after each of the dives. Nitrox breathing during the dives increases the sum of bottom times to 69 min; an increase of 44% from the allowable maximum for air breathing.

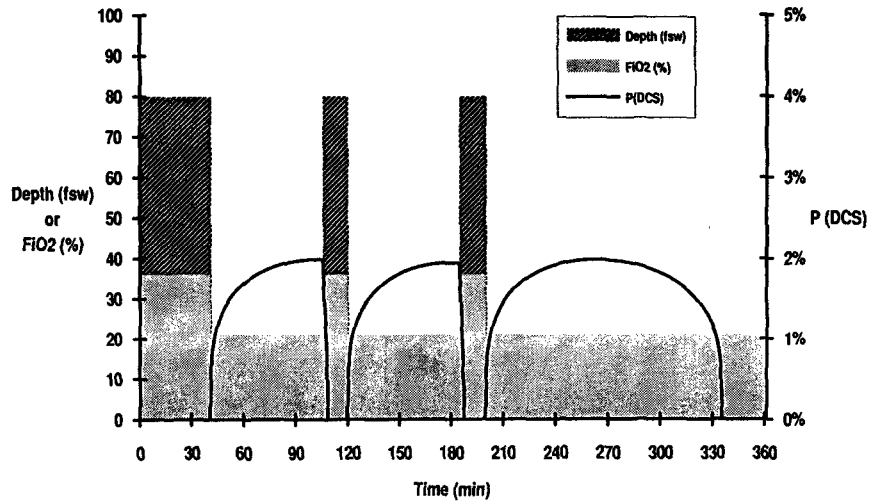

Figure 3. Computed 2.0% iso-risk repetitive dive schedule and corresponding DCS probability profile for three no-stop dives to 80 fsw with nitrox (36% O<sub>2</sub>; balance N<sub>2</sub>) breathing during the dives and air breathing at surface. The duration of each surface interval was fixed at 65 min.

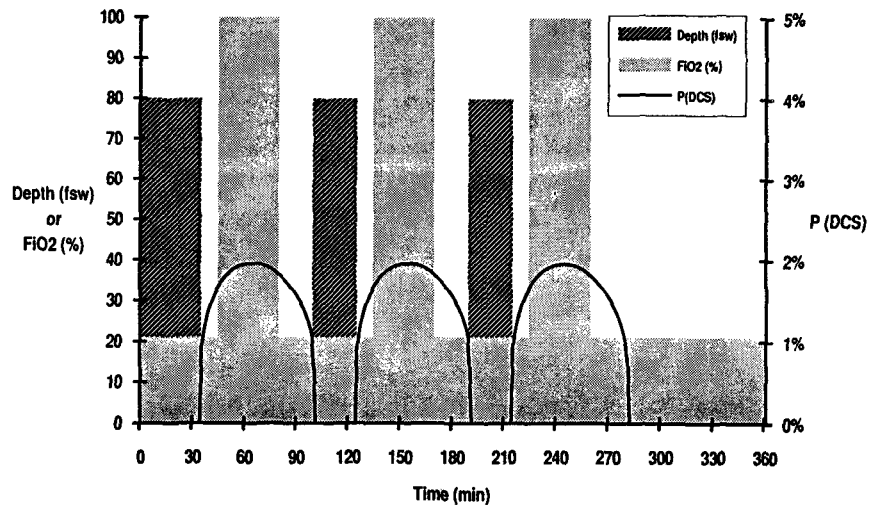

Figure 4. Computed 2.0% iso-risk repetitive dive schedule and corresponding DCS probability profile for three no-stop dives to 80 fsw with air breathing during the dives and 100% oxygen breathing for 35 min at surface after each dive. Each surface interval was fixed at 65 min duration.

Figure 4 shows the profile as calculated when air is breathed during the dives, but 100% oxygen is breathed for 35 min commencing 10 min after surfacing from each dive. This interval of oxygen breathing at surface increases the sum of bottom times to 84 min; a value 75% greater than that

allowable for air breathing only. This increase also exceeds that afforded by nitrox breathing at depth, indicating that surface interval oxygen breathing is a more effective DCS deterrent than nitrox breathing at depth.

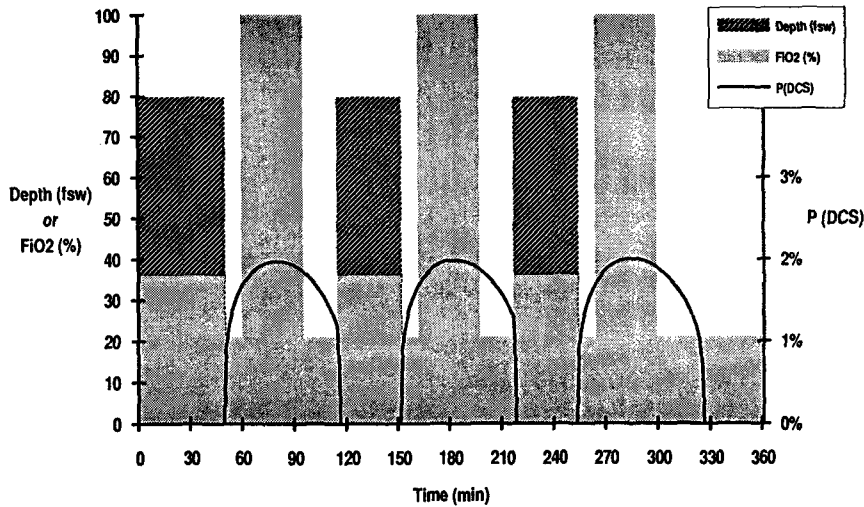

Figure 5. Computed 2.0% iso-risk repetitive dive schedule and corresponding DCS probability profile for three no-stop dives to 80 fsw with nitrox breathing during the dives and 100% oxygen breathing for 35 min at surface after each dive. Each surface interval was fixed at 65 min duration.

Finally, Figure 5 shows the profile for the three dives when nitrox breathing at depth and oxygen breathing at surface are combined. The sum of the bottom times is 123 min, or 156% greater than that allowable when only air is breathed. As summarized in Table III, the use of oxygen-enriched breathing media during all stages of the profile theoretically affords the highest total bottom time.

Table III. Theoretical Effects of Oxygen and Nitrox Breathing on Maximum Bottom Times in No-Stop Repetitive Dives to 80 FSW with 65 min Surface Intervals (2.0% Maximum DCS Probability).

Respired Gas (Depth/Surface)	Air/Air	Bottom Time (min)		
		Nitrox/Air	Air/SI O <sub>2</sub>	Nitrox/SI O <sub>2</sub>
Dive 1	28	40	34	49
Dive 2	10	14	25	37
Dive 3	10	15	25	37
Total	48	69	84	123

These increases in allowable bottom times can be put in another perspective by considering the DCS probability profile that would obtain if the nitrox/SI O<sub>2</sub> repetitive dive schedule in Figure 5 is performed unchanged except with air breathing throughout. As shown in Figure 6, the DCS probability after each of the dives in the series increases to values in excess of the 2.0% limit. Another feature is also evident after the third dive, where the DCS probability is maximal at 7% immediately after surfacing, falls during the ensuing 140 min to about 4%, and thereafter resumes a slight rise followed by a much attenuated decline. This behavior indicates that the decompression outcome is governed over different periods by first one, then the other of the two tissue compartments in the model. The effects of the first governing tissue, which were not evident in the previously illustrated profiles, are typical of a tissue that hosts a bubble with a negligible bubble-tissue diffusion barrier. The emergence of these



effects after only the third dive is a consequence of the relatively slow gas exchange kinetics of this compartment (half-time = 549 min).

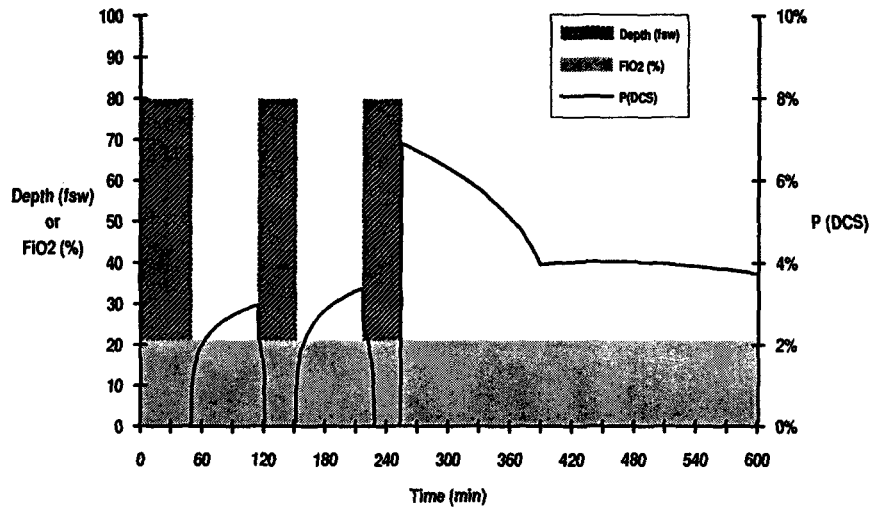

Figure 6. Computed DCS probability profile for the repetitive dive schedule shown in Figure 5, but with air breathing throughout the schedule.

The advantages of using oxygen-enriched air can also be viewed as they influence the surface intervals between dives of fixed duration to specific depths. Again, repetitive dives to 80 fsw can be used as examples, taking the bottom time of 28 min from the first of the air-only dives in Figure 2. With air breathing throughout, a surface interval of 678 min is required before this dive can be repeated with the same 2.0% DCS probability. If 36% nitrox is breathed during the same 28 min dive, this surface interval is theoretically reduced to 124 min.

### Conclusions

Theoretical advantages of using nitrox at depth and surface interval oxygen in repetitive dive series can be quantitatively assessed using available laboratory and field experience through modeling efforts based on maximum likelihood. The models allow computation of iso-risk decompression schedules that incorporate these advantages to achieve longer bottom times and shorter surface intervals than those allowed by present US Navy tables.

### References

- Fawcett, T.A., R.D. Vann and W.A. Gerth. 1992. Surface interval oxygen: Rationale and study design. *In: Lang, M.A. and R.D. Vann (Eds.). Proceedings of AAUS Repetitive Diving Workshop. Duke University, March 1991. AAUS, Costa Mesa, CA. pp. 293-298.*
- Hamilton, R.W., D.J. Crosson and A.W. Hulbert (Eds.). 1989. Workshop on enriched air nitrox diving. NOAA NURP Research Report 89-1.
- Homer, L.D. and R.C. Bailey. 1977. An analogy permitting maximum likelihood estimation by a simple modification of general least squares algorithms. NMRI Technical Report 77-55.
- Lauckner, G.R., R.Y. Nishi and B.C. Eatock BC. 1984a. Evaluation of the DCIEM 1983 decompression model for compressed air diving (Series A-F). DCIEM Report 84-R-72.

- Lauckner, G.R., R.Y. Nishi and B.C. Eatock. 1984b. Evaluation of the DCIEM 1983 decompression model for compressed air diving (Series G-K). DCIEM Report 84-R-73.
- Marquardt, D.W. 1963. An algorithm for least-squares estimation of nonlinear parameters. *J. Soc. Indust. Appl. Math.* 11: 431-441.
- Nishi, R.Y., B.C. Eatock, I.P. Buckingham and B.A. Ridgewell. 1982. Assessment of decompression profiles by ultrasonic monitoring. Phase III: No-decompression dives. DCIEM Report 82-R-38.
- Nishi, R.Y., G.R. Lauckner, B.C. Eatock and J.T. Hewitt. 1984. Oxygen decompression techniques for compressed air diving using the XDC-2 decompression computer programmed with the Kidd-Stubbs 1971 model. DCIEM Report 84-R-19.
- Rogers, R.E. 1992. DSAT dive trials: Testing of the recreational dive planner. *In: Lang, M.A. and R.D. Vann (Eds.). Proceedings of AAUS Repetitive Diving Workshop. Duke University, March 1991. AAUS, Costa Mesa, CA. pp. 299 - 309.*
- Thalmann, E.D. 1980. Testing of decompression algorithms for use in the U.S. Navy Underwater Decompression Computer. NEDU Report No. 11-80.
- Thalmann, E.D. 1984. Phase II testing of decompression algorithms for use in the U.S. Navy Underwater Decompression Computer. NEDU Report No. 1-84.
- Thalmann, E.D. 1986. Air-N<sub>2</sub>O<sub>2</sub> decompression computer algorithm development. NEDU Research Rep. No. 8-85.
- Weathersby, P.K. 1986. Human decompression trial in nitrogen-oxygen diving. NMRI Report 86-97.
- Weathersby, P.K., L.D. Homer and E.T. Flynn. 1984. On the likelihood of decompression sickness. *J. Appl. Physiol.: Respirat. Environ. Exercise Physiol.* 57(3): 815-825.

## APPLICATION OF MAXIMUM LIKELIHOOD ANALYSIS TO REPETITIVE AIR DIVING

*Peter Tikuisis*

*Ronald Y. Nishi*

Defence and Civil Institute of Environmental Medicine

1133 Sheppard Ave W.

P.O. Box 2000

North York, Ontario, M3M 3B9 CANADA

*The present study examines the application of the method of maximum likelihood to repetitive air dives. The method of maximum likelihood optimizes the parameters of a probabilistic model for the prediction of decompression sickness (DCS). The optimization procedure matches as closely as possible the predicted incidence of DCS to the observed incidence from dive data. The model selected for the present study is based on the supersaturation of nitrogen in two parallel compartments having different time constants and risk factors which are the parameters of the model. The data involves 1299 trials (3811 man-dives) including dives on air and nitrox, and some with 100% oxygen during portions of the decompression. Of these trials, 21 were repetitive air dives of varying depths and bottom times. The mean incidence of DCS for the whole data set was 2.52%. After the model parameters were optimized (time constants of 12.3 and 180 min, and risk factors weighted approximately in the ratio of 1:2), the model was then applied to the repetitive dives for a predictive analysis. The results of this analysis are presented in detail and a comparison is made with the predictions obtained when the bottom time of the second dive is shortened in accordance with the DCIEM Sport Diving Tables. The predicted probability of DCS decreased, but insignificantly; values ranged from 1.2 to 3.8% for the original dives and from 1.1 to 3.2% for the sport dives.*

### Introduction

The method of maximum likelihood analysis has been applied to predict the outcome of decompression sickness (Tikuisis *et al.*, 1988; Weathersby *et al.*, 1984) and to generate statistically-based decompression tables (Weathersby *et al.*, 1985). The method is powerful since dives having different depths and bottom times can be combined to arrive at predictions with much "tighter" confidence limits than that obtained by using the more restrictive approach of examining the outcome of only those dives having the same depth and bottom times (Tikuisis *et al.*, 1988; Weathersby *et al.*, 1984). Dives of different gas composition can also be combined using maximum likelihood as demonstrated recently with air and heliox dives (Tikuisis *et al.*, 1991). Following a brief review of the method of maximum likelihood, the data used in the present analysis will be described and predictions for selected repetitive air dives will be detailed.

### Method of Maximum Likelihood

The risk of decompression sickness (DCS) is assumed to increase with an increase in gas supersaturation in the body. However, it is the integrated value of the gas supersaturation that is important. Also, only the inert component of the inspired gas is considered; in the present analysis, the inert component is nitrogen.

The level of gas supersaturation in the body and the impact that this level has on the risk of DCS are predicted by a probabilistic model. Several different types of models have been examined in the past, but all are driven by the common variables of time and depth. The model configuration, selected on the basis of previous success (Tikuisis *et al.*, 1988; 1991), is two compartments in parallel (see Fig. 1) with different time constants for gas uptake and elimination, and different weighting factors for the contribution to the risk of DCS. A small time constant pertains to the "fast" compartment and a large value pertains to the "slow" compartment. These time constants are the kinetic parameters of the model. Whenever a compartment's inert gas pressure exceeds the ambient pressure, it contributes to the risk of DCS. The extent of this contribution is determined by the gain which is the compartment's risk weighting factor. The time constants and gains are the only parameters considered in the present 2-parallel compartment model.

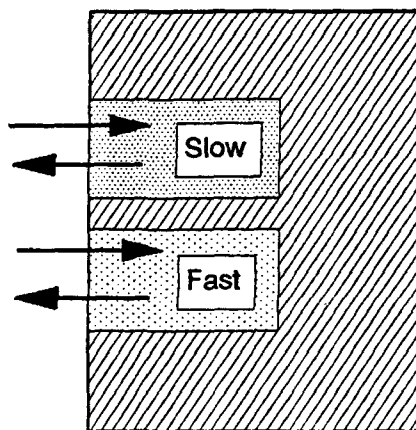

Figure 1. Schematic of the 2-parallel compartment model.

The method of maximum likelihood (Edwards, 1972) optimizes the values of the model parameters through a modified Marquardt algorithm (Marquardt, 1963) that matches as closely as possible the observed and predicted DCS outcomes. First, the probability of DCS is expressed in terms of the risk function (Tikuisis *et al.*, 1988; Weathersby *et al.*, 1984) as

$$pDCS = 1 - \exp(- \int r . dt )$$

where  $r$  is the sum of weighted gas supersaturations (gain x gas supersaturation) of the two compartments. Next, the log-likelihood function is evaluated for each diver of each dive in the data set as

$$LL = y . \ln(pDCS) + (1 - y) . \ln(1 - pDCS)$$

where  $y$  is the actual outcome (0 for no DCS, 0.5 for a marginal hit, and 1 for DCS). The closer in agreement that  $y$  is to the predicted outcome, then the higher the sum of  $LL$  becomes (note that  $LL$  is negative since  $0 < pDCS < 1$ ). Maximum likelihood follows an iterative process that adjusts the model parameters until the smallest absolute value of  $LL$  is attained.

#### Data and Parameter Estimation

The data used in this study are from experimental chamber dives and are summarized in Table 1. The data include both dry and wet divers on air, some nitrox dives, and some dives involving 100%

oxygen during portions of decompression. Of the 1299 trials, 21 were repetitive air dives (surface interval ranging from 30 to 90 min) involving 92 man-dives with no incidence of DCS. The mean incidence of DCS for the whole data set was 2.52%.

**Table 1. Summary of dive data.**

No. trials	1299
No. man-dives	3811
Incidence of DCS	2.52%
Depth (msw) mean and range	53.3 9.0 - 92.4
Bottom Time (min) mean and range	26.1 2.6 - 360.0
Dive Time (min) mean and range	93.8 8.1 - 1095.0

Maximum likelihood with the 2-parallel compartment model was obtained according to the convergence criteria outlined in Tikuisis, *et al.* (1991) with a *LL* value of -411.30; this represents a significant improvement over the value of -448.19 obtained by assuming a fixed probability of DCS for all dives equal to the observed mean value of 2.52%. Upon convergence, the following parameter values ( $\pm$ SE) were obtained: time constants of 12.3 (21.7) and 180 (57) min, and gains of 0.00074/min ( $\pm$ 0.00056) and 0.00147/min ( $\pm$ 0.00034) for the "fast" and "slow" compartments, respectively. The high SE of the estimates for the "fast" compartment indicates a large degree of uncertainty despite the large number of man-dives analyzed (in excess of 3800) and the wide range in depths and bottom times (see Table 1). Nevertheless, when categorized according to low and high risk of DCS, the predictions are in good agreement with the observations. For example, all dives for which the predicted DCS was less than 2.52% had a predicted mean incidence of 1.14% compared to the observed mean of 1.24%, and of those greater than 2.52%, the predicted mean incidence was 4.81% compared to the observed mean of 4.64%.

### Analysis of Repetitive Air Dives

Having obtained the above model parameters, predictions of the probability of DCS can be obtained for any dive profile. Further, the method of maximum likelihood provides the means to calculate the 95% confidence limits of the predictions. Table 2 shows the results of such a propagation of errors applied to the 21 repetitive air dives in the data set. The first and second columns give the dive number and profile description coded as depth : bottom time : surface interval : depth : bottom time where depths and times are rounded off in msw and min, respectively. The bottom times include the excursion time to depth. The third column indicates the number of divers, and the fourth and fifth columns indicate the predicted probability and 95% confidence interval of DCS. The predicted incidence averaged 2.7% and did not exceed 4% for any of the dives; furthermore, the confidence intervals are reasonably narrow. Since there was no observed incidence of DCS for these dives, they may be considered safer than predicted. This small disparity may be due to the relatively small number of repetitive dives used in the data set to establish the model parameters. Dives with a recorded incidence of DCS have a larger impact on the estimation of parameters than dives for which no DCS was observed, as was the case for the 21 repetitive air dives.

Figures 2, 3, and 4 show the time/depth profiles of three distinct dives selected from the 21 repetitive air dives in the data set. These are #2438A, #2426A, and #2443A where the repetitive dive is either at the same depth but of shorter duration than the first, at a greater depth and shorter duration than the first, or at a shallower depth and longer duration than the first, respectively (see Table 2). Also shown in these figures is the predicted probability of DCS over time. The risk of DCS continues to increase for as long as a state of gas supersaturation exists in at least one of the two model

compartments. Hence, *pDCS* is zero until ascent to the surface begins after the first dive, and upon surfacing, *pDCS* begins to increase. During the time at depth of the second dive, *pDCS* decreases negligibly and upon surfacing, *pDCS* is seen to increase and slowly approach its final value attained when there is no longer any gas supersaturation in either of the two model compartments. This occurs at 128.7, 120.0, and 105.4 min after the termination of the second dive for the respective profiles of Figs. 2, 3, and 4.

Table 2. Prediction of DCS for Repetitive Air Dives in data set.

Dive ID	Profile	NY	pred DCS (95% confd)
2408A	18:30:60:18:36	5	2.5 (1.8 - 3.6)
2410A	18:30:60:18:36	4	2.5 (1.8 - 3.6)
2412A	34:12:30:34:8	5	1.5 (0.7 - 3.6)
2414A	34:12:30:34:8	3	1.5 (0.7 - 3.5)
2416A	40:8:60:40:7	3	1.2 (0.3 - 4.9)
2418A	40:8:60:40:7	4	1.2 (0.3 - 4.9)
2420A	37:10:60:18:38	4	2.4 (1.6 - 3.6)
2422A	37:10:60:18:38	4	2.4 (1.6 - 3.7)
2424A	18:50:90:18:33	5	3.8 (2.8 - 5.1)
2426A	15:75:60:27:12	5	3.8 (2.5 - 5.8)
2428A	15:75:60:27:12	3	3.8 (2.5 - 5.8)
2431A	18:30:60:18:36	4	2.5 (1.7 - 3.5)
2433A	18:30:60:18:36	5	2.5 (1.8 - 3.6)
2435A	33:12:30:33:9	5	1.5 (0.7 - 3.5)
2438A	18:50:90:18:33	6	3.7 (2.8 - 5.1)
2441A	40:8:60:40:7	4	1.2 (0.3 - 4.8)
2443A	37:10:60:18:38	6	2.4 (1.5 - 3.7)
2445A	15:75:60:27:12	4	3.8 (2.5 - 5.8)
2447A	15:75:60:27:12	4	3.8 (2.4 - 5.8)
2449A	18:50:90:18:33	5	3.8 (2.8 - 5.1)
2451A	18:50:90:18:33	4	3.8 (2.7 - 5.1)

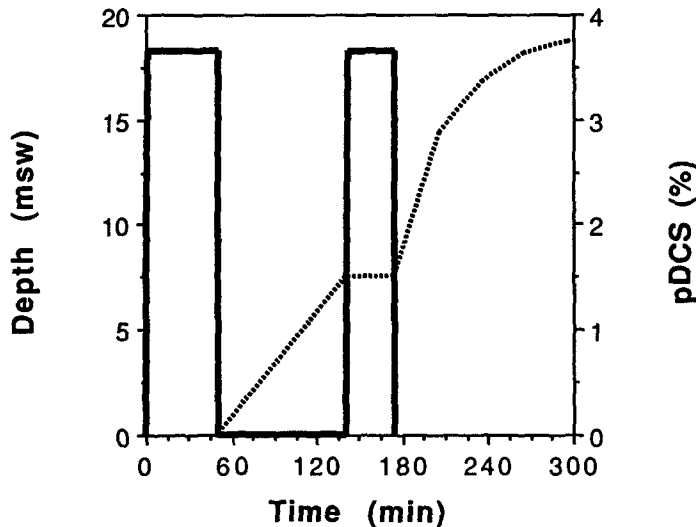

Figure 2. Time/depth profile and predicted probability of DCS for dive #2438A (see Table 2).

An interesting inquiry that can be examined using maximum likelihood is to what extent the risk of DCS is reduced by following the more conservative DCIEM Sport Diving Tables. These tables shorten the bottom time of the second dive compared to those listed in Table 2. There are essentially six different profiles among the 21 repetitive air dives and these are listed in Table 3 where the numeric portion of the dive ID corresponds to those in Table 2. A propagation of errors for these dive profiles leads to predicted outcomes which range from 0.1 to 0.6% less than that obtained with the longer bottom times of Table 2. Although this analysis has not shown any significant differences in *pDCS*

between the two types of profiles according to the confidence intervals, it demonstrates the feasibility of using the method of maximum likelihood for such analysis.

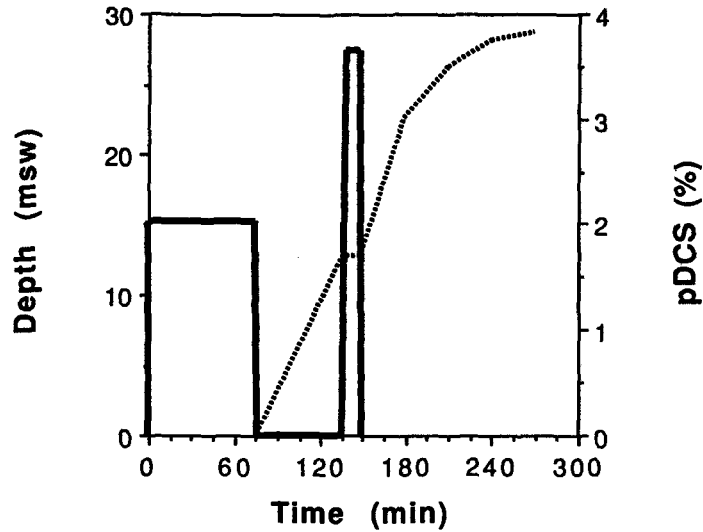

Figure 3. Time/depth profile and predicted probability of DCS for dive #2426A (see Table 2).

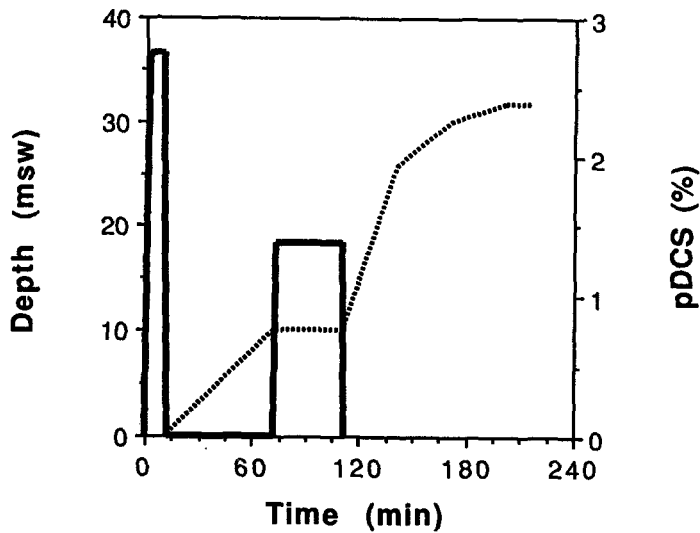

Figure 4. Time/depth profile and predicted probability of DCS for dive #2443A (see Table 2).

Table 3. Prediction of DCS for selected DCIEM Repetitive sport dives.

Dive ID	Profile	pred DCS (95% confd)
2408S	18:30:60:18:29	2.0 (1.3 - 3.0)
2412S	34:12:30:34:7	1.4 (0.6 - 3.4)
2416S	40:8:60:40:6	1.1 (0.2 - 5.0)
2420S	37:10:60:18:30	1.9 (1.1 - 3.2)
2424S	18:50:90:18:26	3.2 (2.3 - 4.5)
2426S	15:75:60:27:9	3.3 (2.1 - 5.3)

### References

- Edwards, A.W.F. 1972. *Likelihood*. Cambridge University Press, Cambridge, England.
- Marquardt, D.W. 1963. An algorithm for least-squares estimation of non-linear parameters. *J. Soc. Ind. Appl. Math.* 11: 431-441.
- Tikuissis, P., P.K. Weathersby and R.Y. Nishi. 1991. Maximum likelihood analysis of air and HeO<sub>2</sub> dives. *Aviat. Space Environ. Med.* (in press).
- Tikuissis, P., R.Y. Nishi, and P.K. Weathersby. 1988. Use of maximum likelihood method in the analysis of chamber air dives. *Undersea Biomed. Res.* 15(4): 301-313.
- Weathersby, P.K., J.R. Hays, S.S. Survanshi, L.D. Homer, B.L. Hart, E.T. Flynn and M.E. Bradley. 1985. Statistically based decompression tables II. Equal risk air diving decompression schedules. NMRI Report 85-17, Naval Medical Research Institute, Bethesda, MD.
- Weathersby, P.K., L.D. Homer and E.T. Flynn. 1984. On the likelihood of decompression sickness. *J. Appl. Physiol.* 57:815-825.



## STATISTICALLY BASED DECOMPRESSION TABLES

Gary W. Albin  
Naval Medical Research Institute  
Bethesda, MARYLAND 20889-5055 U.S.A.

*A discussion is presented of the use of likelihood maximization to fit models to data on diving decompression sickness, with the goal of using those calibrated models to generate diving tables or to form the nucleus of an algorithm for calculating a safe ascent schedule in real time with a diving computer. The process is illustrated by discussing an ongoing project at the Naval Medical Research Institute (NMRI). The reasons for choosing likelihood maximization as the tool in this analysis, the models explored at NMRI, the criteria for a good database, and the way the models have been evaluated for suitability in the two stated applications are the major points of the discussion. The paper might serve as an informal overview for the diving community.*

### Introduction

This paper describes the use of maximum likelihood analysis as a means to rigorously fit models to data on the incidence of decompression sickness, and the use of those calibrated models for generating diving tables or for driving the algorithm that controls a dive computer. To demonstrate likelihood maximization, some statistical studies of decompression sickness performed at the Naval Medical Research Institute (NMRI) will be examined. The technique is illustrated using specific numerical examples taken from this case study.

### Why Use Likelihood Maximization?

Likelihood maximization is a means of rigorously fitting mathematical models to binary, probabilistic data. Binary data are derived from experiments that have only two possible outcomes. For example, if the interest is in decompression sickness (DCS), then "DCS" and "no DCS" can be considered the two possible outcomes of a dive. Binary data are distinct from continuous data, measured for most processes. Probabilistic data determine the outcome of an experiment as a random event. That is, predicting the outcome of the process is no better than assigning probabilities to two or more alternative outcomes. The designation "random" is seen to be the opposite of "deterministic".

Rain is a random event: it cannot be predicted with certainty whether or not it will rain, but the probability of rain can be estimated. Decompression sickness is another example. DCS demonstrates its randomness when two divers on the same dive schedule end up with different outcomes (*i.e.*, one with DCS, one without DCS), or, a diver is bent on the same schedule that he completes successfully at other times. Since there is no ultra-sophisticated model that would explain just why DCS occurred in one case but not in another seemingly identical situation, DCS appears to be random. If sufficient information on the divers and enough understanding of the etiology of DCS were present, then DCS might cease to look random. However, the understanding of the etiology of DCS is not much greater than the weatherperson's understanding of the etiology of rain showers.

### The Transfer Function

The transfer function is the model that converts the dive profile to which a diver is exposed to the probability that the diver will suffer DCS. The transfer function is the model used to convert a dive exposure to a probability of DCS. What should this transfer function look like? Formulation of a reliable deterministic model is extremely difficult, but there are features that might be useful in a probabilistic model. Therefore, plausible models can be proposed, but we cannot *a priori* say which of them is best for predicting the probability of DCS. Instead, the models need to be tested by determining how well they can fit the available diving data.

First, should the transfer function be the same for every diver? Consider that, if the observer has little or no information on the individual divers that is expected to be relevant to their risk of DCS, then it is difficult to differentiate among their risk levels by assigning them different transfer functions. For the studies at NMRI, most of the data were taken from published sources that were not uniform in the sort of diver-specific information that was included. There seems to be no one potentially useful index (e.g. a reliable measure of body fat) that is recorded for all or even most of the divers in the NMRI database. Consequently, all divers are treated as equal for the purpose of assembling data; the same transfer function is postulated for all divers.

Specific mathematical forms for the transfer functions have been proposed by Weathersby *et al.* (1984, 1985) and Thalmann (1984). The definition of an "overpressure function" whose instantaneous value in a certain hypothetical "tissue" is given by a modified relative overpressure is as follows:

$$\Psi(t) = A [ P_{\text{tissue}(t)} - P_{\text{ambient}(t)} - P_{\text{thr}} ] / P_{\text{ambient}(t)} \quad (1)$$

where  $\Psi$  = overpressure function,  $\text{min}^{-1}$ ;

A = gain coefficient,  $\text{min}^{-1}$ ;

$P_{\text{tissue}}$  = partial pressure of dissolved gas in the tissue, atm;

$P_{\text{ambient}}$  = ambient hydrostatic pressure, atm;

$P_{\text{thr}}$  = threshold overpressure, atm.

Removal of the parameters A and  $P_{\text{thr}}$ ,  $\Psi$  becomes simply the relative overpressure that was used as the index of a dive schedule's safety when the current U.S. Navy dive tables were computed. As for the parameters that have been added to the traditional expression, the gain A and the threshold  $P_{\text{thr}}$  generally are treated as adjustable parameters when the models are fit to data; in other words, their values are optimized to improve the fit of the model to the data. The value of  $P_{\text{thr}}$  may be fixed at zero.

To evaluate the overpressure function of a tissue at time t, there must be a value for  $P_{\text{tissue}}$  at that time, requiring a model of gas exchange kinetics. The current U.S. Navy tables were generated using the familiar single, exponential kinetics, not because that model was physiologically correct, but because it made the numbers easy to compute. The single exponential model is also proposed as one possible representation of gas uptake and washout:

$$P_{\text{tissue}} = P_{\text{tissue},0} \exp (-t/\tau) \quad (2)$$

where  $\tau$  = the tissue's time constant, min. A smaller time constant means faster uptake of gas during compression and faster release of the gas during decompression.

Other models of gas exchange kinetics might be tried as well. In experiments at NMRI, xenon gas kinetics in dog muscle are better described by a double exponential function (Novotny, *et al.*, 1990) given appropriate values for the two time constants, so a double exponential kinetic model might be more effective because it seems to be more physiologically correct. Lastly, a more complicated model, called "linear/exponential" might be tried. According to this model, gas is taken up by a tissue at a rate governed by the single exponential model. During offgassing the  $P_{\text{tissue}}$  is a quadratic function of time as

long as the overpressure is greater than a certain crossover value; as soon as the overpressure drops below that point, the offgassing kinetics become single exponential. The value of the overpressure at which the crossover between kinetic models takes place is another one of our adjustable parameters. Under special circumstances the quadratic kinetics simplify into linear kinetics ( $P_{tissue}$  then becomes a linear function of time) and hence the designation "linear/exponential" for this kinetic model.

Figure 1 shows an experimental repeat dive taken from the NMRI database. The solid lines are hydrostatic pressures in atmospheres. The dotted straight lines show the instantaneous partial pressure of inert gas in the inspired gas mix. The dotted curves are the instantaneous tissue partial pressures ( $P_{tissue}$ ). Here, two tissues are postulated, one having a time constant  $\tau$  of 95 min and the other a time constant of 508 min. The gas exchange kinetics are postulated as being single exponential at all times. According to this model, the overpressure function can be positive whenever the  $P_{tissue}$  is greater than  $P_{ambient}$ , as long as the parameter  $P_{thr}$  in equation (1) is zero. In this example, the faster tissue (the 95-minute time constant) can have a positive overpressure until about 600 min after the start of the dive, whereas the slower tissue can have a positive overpressure until about 1100 min after the start.

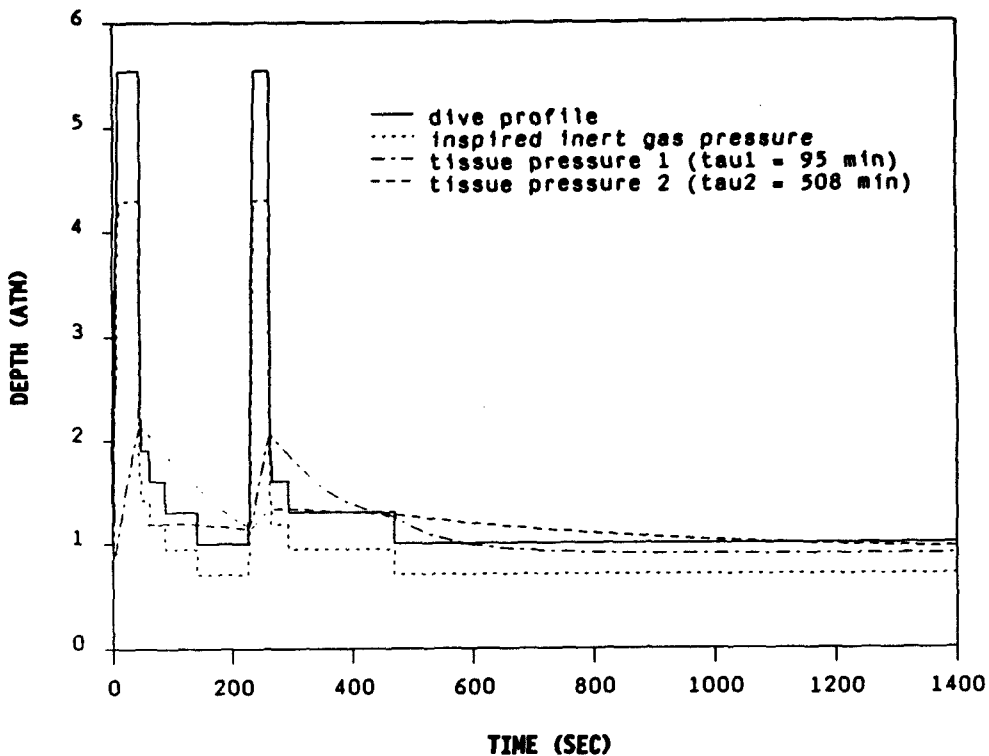

Figure 1. Illustration of single exponential kinetics of gas exchange.

Double exponential kinetic models lead to curves that are subjectively so similar to the curves that arise from single exponential models that, typically, it is almost impossible to distinguish which of the two models generated a given gas washout curve. Nevertheless, mathematically, they are substantially different and they do represent two distinct descriptions of the system.

In figure 2, the same dive and tissue time constants are shown as in Figure 1, but the linear/exponential model is being invoked and linear kinetics apply for a portion of the offgassing period. The point here is that the offgassing kinetics are considerably different than in Figure 1; the overpressure extends for a longer time after surfacing and the shape of the overpressure curve is different. In general, for a given time constant  $\tau$ , the linear/exponential model has the effect of slowing

down the offgassing kinetics and extending the duration of the overpressure. This can be important for the people seeking to develop an algorithm for calculating a "safe" ascent profile for a diver in real time.

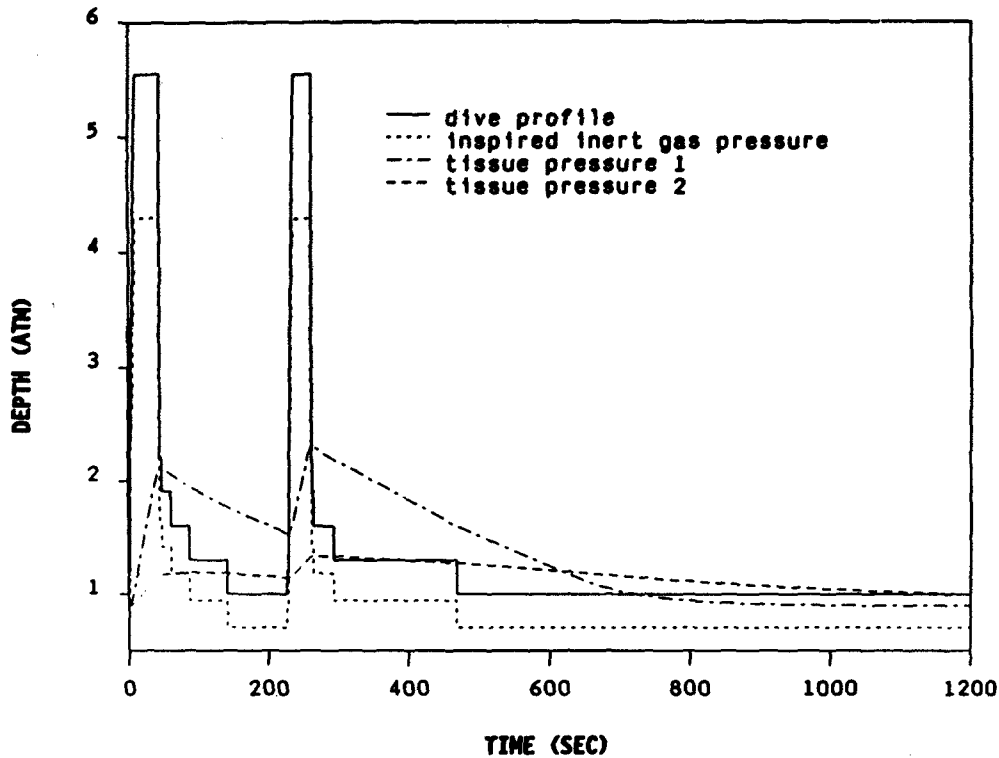

Figure 2. Illustration of linear/exponential kinetics of gas exchange.

Thus, the kinetic models of gas exchange are used for calculating the instantaneous overpressure  $\Psi(t)$  at any time  $t$ . It is commonly believed that DCS is somehow related to gas overpressure in tissue. Therefore,  $P(\text{DCS})$  from a "risk function" can be computed and that risk function might be mathematically related to the overpressure function.

Intuitively, it seems more likely that risk is something that accumulates gradually over the course of the dive rather than something that arises from one or more instantaneous events. One way to represent this mathematically is

$$P(\text{DCS}) = 1 - \exp\left(-\int_0^{\infty} r \, dt\right) \quad (3)$$

where  $r$  = instantaneous risk. According to equation (3)  $P(\text{DCS})$  approaches 1.0 asymptotically as the accumulated risk grows larger, which makes sense.

A further specification is that risk cannot be negative. A negative risk does not make sense intuitively nor mathematically; so, if the calculated risk is less than zero, then assume  $r = 0$ . Also, if there is more than one tissue involved then assume that the total risk is just the sum of the contributions from all of the individual tissues. Mathematically:

$$r_{\text{total}} = \sum r_i \quad (4)$$

One possibility to define a relationship between the risk function  $r$  and the overpressure function  $\Psi$  is simply:

$$r(t) = \Psi(t) \quad (5)$$

A somewhat more complicated expression is

$$r(t) = \left( \int_0^t \right) \Psi dt \quad (6)$$

Equation (6) amounts to integrating the overpressure function twice to arrive at the P(DCS), whereas if equation (5) is used there is only one integration of  $\Psi$ . The double integration extends the risk accumulation over a longer time after decompression starts. Figure 3 is identical to Figure 1 except that the risk is integrated twice instead of just once. In Figure 3, the dotted curves are the function  $r$  according to equation (6) for the two tissues (although it has been multiplied by a scaling factor to make it fit nicely on the graph, its apparent magnitude can be ignored). Where the dotted curves are positive, risk is being accumulated. In Figure 1, the risk accumulates only when there is a tissue overpressure. Examine the risk collected in Figure 3 versus Figure 1.

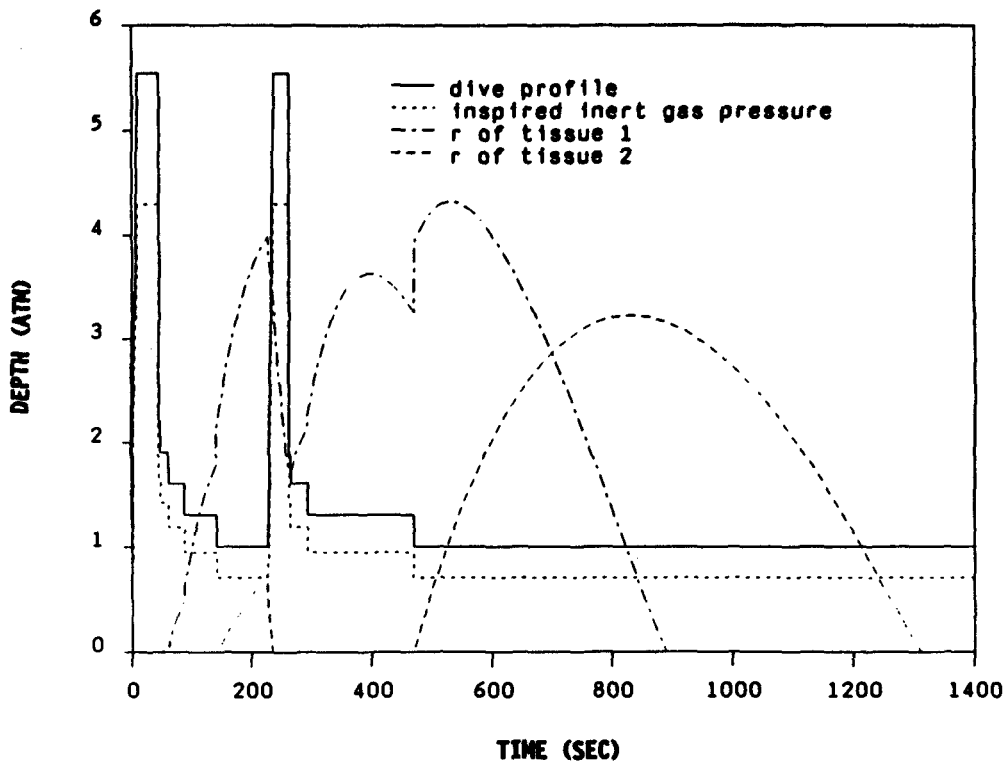

Figure 3. Illustration of double integration of risk (single exponential kinetics).

Figures 1 and 3 also illustrate that the general shape of the risk accumulation curve, as well as its duration, depends on whether single or double integration is used. Notice from Figure 1 that with single integration, the instantaneous risk maximizes at the moment that the diver completes an upward pull, then decreases monotonically. In general, models with single integration indicate that the risk accumulates most rapidly immediately after an ascent, implying that symptoms should occur most often soon after ascending. In Figure 3 (double integration) the maximum instantaneous risk is delayed for

some time after each pull. The double integration models therefore predict that symptom onset is most likely to be delayed following an ascent.

The chosen models are consistent with the perception that risk increases with the time at depth (which results in more uptake of gas in the models) and the perception that a slower decompression diminishes risk (because more time is allowed for offgassing, which decreases the overpressure at a given time).

It must be clarified that the "tissues" mentioned here are not real tissues; they are just mathematical constructs without definite physiological counterparts. The single exponential and double exponential models contain little to indicate what sort of physiological event is responsible for DCS. The linear/exponential model was in fact derived with a certain physiological process in mind – the onset of quadratic kinetics is conceptually linked with separation of a gas phase, and the return to exponential kinetics is supposedly associated with the disappearance of the gas phase. But none of the models should be taken seriously as descriptors of a real process. They are strictly empirical in nature. This is acceptable, though, because the transfer function does not have to be a good descriptor of actual physiological processes. It can be anything at all as long as it proves to fit the data well. This model that predicts the probability of DCS is needed even if it does not have the underlying processes quite right.

#### How to Tell Which Model is Best - Fitting to Data

There are three kinetic models for calculating a  $P_{\text{tissue}}$  from which in turn a risk function can be calculated. There are also two means of converting risk to  $P(\text{DCS})$ , namely, by integrating it once or integrating it twice. There can be any number of tissues with several adjustable parameters per tissue. This results in a potentially infinite number of models, any one of which may be good at predicting  $P(\text{DCS})$ . How can one distinguish among all these models? They are all empirical. There is no particular reason to consider any of them good physiological descriptors. Apparently, there is no good reason to favor any one of them over the others.

The answer is to fit models to a carefully collected database and let them prove themselves. Fitting binary data by likelihood maximization is analogous to fitting continuous data by minimizing the sum-of-squares-of-error ("least squares" fitting). The fitting program improves the agreement between data and model by optimizing the values of the adjustable parameters. In practice, the operator feeds the program a set of initial guesses of the optimal parameter values and the program systematically makes iterative adjustments to these parameter values to maximize the "likelihood" of the data set. That is, the program maximizes the probability that the observed set of outcomes ("DCS" or "no DCS") would occur, given that  $P(\text{DCS})$  is governed by the given model.

The parameter values that indicate the highest likelihood of the observed data are considered the best ones. Likewise, the model whose parameter values can be adjusted are favored so that the likelihood of the data is indicated to be higher than with competing models. Weathersby *et al.* (1984) and Edwards (1972) provide a comprehensive discussion of maximum likelihood analysis.

Typically, the highest peak in the likelihood function (the global maximum) is surrounded by lesser peaks. Since the program may converge on these local maxima rather than on the global maximum, the operator must follow a trial-and-error process of feeding the program many diverse sets of initial parameter guesses and letting the program run its course, finding on each run its best estimate of the best parameter values, before being reasonably secure that the global maximum has been found. The length of this process increases dramatically with the number of adjustable parameters; at NMRI, for example, up to 12 adjustable parameters have been attempted and the data fitting has consumed several man-years.

## The Data

A large, diverse, carefully recorded set of dives is needed against which proposed models can be tested. Anecdotal data do not meet the criterion of "well-recorded". Because of statistical considerations, we cannot get useful parameter estimates by fitting the models to sparse databases consisting of, say, 2 DCS cases out of 10,000 dives or the like. Above all, we should not fit our models to diving tables rather than real data, as others have done!

The NMRI database consists of almost 2400 experimental dives done under the supervision of the U.S., Canadian, and British Navies. They include 76% single dives, 19% repeat dives (in which the diver surfaces in the intervals between two or more deep excursions), and the remainder "multiple depth" dives (which feature ascents to a relatively shallow depth interspersed with two or more deep excursions). They are diverse as far as their time scales; they include both saturation dives and simulated submarine escapes. Most of the dives are on air and the rest are on various  $N_2/O_2$  breathing mixtures. The overall incidence of DCS is about 7%. The protocols under which the dives were performed are detailed by Nishi *et al.* (1980, 1981, 1982, 1984), Lauckner *et al.* (1984, 1985), Thalmann (1980, 1984, 1986) and Weathersby *et al.* (1987).

It is important to get as many man-dives as possible into the data set without compromising the quality of the data (bad data, *e.g.* dives with sloppily recorded depth-time histories or dives with uncertain diagnoses, are worse than none at all). More data means more information, which puts more constraints on the data fitting program and lets it estimate the adjustable parameters more precisely. This ultimately leads to more precise predictions of the P(DCS) of dives. It is also desirable to have plenty of DCS cases as well as uneventful dives in the data set, because the program needs to see examples of both outcomes before it can distinguish between relatively safe and relatively unsafe exposures (this is why there would be a problem with trying to learn much from a sparse data set containing only a few DCS cases).

It is important to note that we counted marginal DCS cases as being equal to 0.1 DCS case. By marginal cases, we mean niggles, skin bends, and fleeting pains. Counting one of these as 0.1 DCS case reflects our perception that a marginal symptom is only about one-tenth as worrisome as a more painful DCS event. Obviously, the choice of "0.1" is arbitrary. Counting the marginal cases as "zeros" would be the same as ignoring them altogether, which seems unreasonable. Likewise, counting them as "ones" would make the dives in our database appear considerably more hazardous, and would have given these marginal cases more influence in the data fitting than we felt was warranted.

### Data-Fitting for the Purpose of Generating Dive Tables

Fitting the models to data for computing P(DCS) prospectively is good for generating dive tables. By "prospective" probability of DCS we mean the probability that the diver will be bent given that he/she chooses some dive profile before descending and follows that profile from beginning to end. Thus, the diver looks at a diving table and chooses a schedule that gives what he/she considers an acceptable level of risk and follows that schedule. To generate the tables that those divers follow, we calibrate the models against data by using the models to calculate the overall risk of the dive, from beginning to end, without much regard for when during the dive the risk is generated. The shape of the risk-versus-time curve does not matter in this situation.

We did this using likelihood maximization. We used the single integration of  $\Psi$  to yield the P(DCS) [see equation (5)]. The following models of gas kinetics were tried: the single exponential with up to three separate "tissues" (up to 7 adjustable parameters were tried) and the double exponential with one or two tissues (up to 8 adjustable parameters). A review of the major observations (Albin and Weathersby, in prep) found that both single and repeat dives on various  $N_2/O_2$  mixes are well described by the same models with the same values of the adjustable parameters. We saw no evidence

that they are from different statistical populations under these models. Therefore, we do not treat repeat dives as a special case separate from single dives. However, multiple depth dives and O<sub>2</sub> decompression dives cannot be "combined" with the other dives in our data set under these models. This means that different parameter values are needed for adequate prediction of the outcomes of those dives than for the rest of the dives. (Whereas the models are empirical, it is not surprising they fail on some of the dives while describing others well.) Our data on both types of oddball dives are sparse: 128 multiple depth dives with just 2 DCS cases and only 45 O<sub>2</sub> decompression dives with 2 DCS cases and 1 marginal DCS case. Therefore, given that there are not enough data on either category of dive to let us fit the models to them alone, and given that these dives do not seem to be well described by the same models that do well for the rest of the data, there is little that we can say now about the hazards of multiple depth dives or O<sub>2</sub> decompression dives.

### Data-Fitting for the Purpose of Writing a Dive Computer Algorithm

It is convenient, for repeat diving especially, if the diver can carry a machine that computes a "safe" ascent schedule in real time. Just what constitutes "safe" is a subjective question beyond the scope of the present discussion. It would be appropriate if the algorithm for computing the ascent schedule had been calibrated against real data. For this application, a conditional probability of DCS is computed, which is quite different from the prospective P(DCS) mentioned in the last section.

A conditional probability is the probability of some event, given that some specified condition holds true. The conditional P(DCS) of interest is the probability of suffering DCS after time T given that no DCS symptoms have appeared before time T. The significance of this definition is that, as a diver proceeds through a dive he/she wants the computer to say how much risk lies ahead, not how much there was in the past. The diver (and the computer) can forget about the risk to which he has been exposed before time T; he already has made it that far without DCS.

Therefore, the computer should continually update the future ascent schedule based on its computation of the conditional P(DCS) as defined above. In our models, that conditional probability would be obtained simply by summing all the risk from time T onward, while ignoring the risk accumulated previous to T. The mathematical expression for this is

$$P(\text{DCS}) = 1 - \exp\left(-\int_T^{\infty} r \, dt\right) \quad (7)$$

Consider that in order for the computer to get the conditional probability right, it needs a model that gets the shape of the risk accumulation curve right. It is not good enough any more to have the correct total risk for the complete dive profile. The risk has to be accumulated at the right time during the dive, because of the danger that DCS will happen during a certain portion of the entire dive.

To properly calibrate the model against data one needs to be able to tell the model when the DCS events occurred, *i.e.*, the database must include the "time of bends" information. That way, the fitting program can optimize the values of the adjustable parameters in the model so that most of the risk occurs when most of the symptoms appear.

Because the probability of any event during a given time interval is non-zero only for a non-zero time interval, the time of bends data must be entered as a pair of times bracketing the DCS event. What should those time brackets be? An obvious choice for the upper boundary, call it T<sub>2</sub>, is the time at which the diver reported symptoms. For the lower boundary, T<sub>1</sub>, some time prior to T<sub>2</sub> when the diver definitely had no symptoms should be recorded. That may often be ambiguous. A set of rules for what T<sub>1</sub> should be for a given value of T<sub>2</sub>, is shown in Table 1. The rationale behind the Table 1 entries is as follows: in well-supervised experimental dives, each diver is asked from time to time whether he notices symptoms that might signal the onset of DCS. If we assume when he says "I'm okay" that he



really is, then a good choice for  $T_1$  would be the time when the diver last declared his good health before succumbing to bends. The selected  $T_1$ 's in Table 1 correspond closely to those times for the data at hand.

Table 1. Bracketing the Time of Bends; Choices of  $T_1$

$T_2$  = time when DCS reported  
 $T_1$  = time when definitely no symptoms

$T_2$	$T_1$
before surfacing	previous stop
< 20 min A.S.	last stop
20 min - 1 hr A.S.	10 min A.S.
1 hr - 3 hr A.S.	30 min A.S.
> 3 hr A.S.	2 hr A.S.

A.S. = after surfacing

Modelling subsequently was restarted from scratch with the inclusion of time of bends. It was found that the single integrated models, which had done well at calculating the prospective  $P(\text{DCS})$ , failed at calculating the conditional  $P(\text{DCS})$  when  $T_2$ , the time at which the diver announced his DCS event, came long after surfacing from a relatively mild exposure. The reason was that, according to these models, the risk ceased to accumulate before  $T_1$  was reached so that no risk was incurred during the  $T_1$ - $T_2$  time interval. In other words, according to the models there was no possibility of DCS within the time interval when DCS was recorded in the data as having occurred. The models were predicting zero probability for observed events, and this represents a complete failure of the models (Weathersby *et al.* in press).

Therefore, to describe the data it was necessary to use models that extended the risk accumulation for a longer time after surfacing. The "Transfer function" described two ways of doing that: conversion of the risk function to  $P(\text{DCS})$  by integrating twice instead of just once, or use of the linear/exponential kinetic model. Further trials showed that either method allowed all of the time of bends data to be fit successfully. The linear/exponential kinetic model with single integration of the overpressure function (or "LE1" model) provided the best overall fit to the data set, with the single exponential kinetic model with double integration of overpressure providing the second-best fit. The linear/exponential kinetic model with double integration of overpressure (or "LE2" model) was distinctly less successful because it prolonged the risk accumulation for too long after surfacing, worsening the shape of the risk accumulation curve relative to what the data called for.

The current best fit to the database is obtained with the LE1 model with three tissues. A total of 12 adjustable parameters are used, four for each tissue. The time constants estimated for the tissues are  $1.3 \pm 0.4$  min,  $54 \pm 16$  min, and  $496 \pm 20$  min (here the standard error, a measure of the uncertainty in the estimated value of a parameter, is shown for each time constant to give an idea of the level of precision achieved by the data fitting). The database is not rich enough in information to statistically justify the use of another tissue in the model.

The parameter values that give the best fit to the data set as a whole may not be regarded as the best parameter values for governing the diving practices of the U.S. Navy fleet. When we use the LE1

model with the "best fit" parameters to generate a table of dives with probabilities of DCS of 3% or 5% per dive, we find that the diver usually would be required to make a 10-foot stop as well as a 20-foot stop. This, we are told, is operationally difficult in the fleet. So, we found that we could get rid of the 10-foot stops by artificially manipulating one of the parameter values (the parameter that sets the tissue overpressure at which the crossover from single exponential gas exchange kinetics to linear kinetics occurs in the slowest tissue). If we fix this parameter at a certain value different from what is optimal for fitting the data set as a whole, and then let the rest of the parameters be adjusted by the data fitting program to get the best possible fit to the data, the model can generate 3% or 5% schedules without including a 10-foot stop as the last (and usually longest) stop. The overall fit of the model to the data, as measured by the calculated "likelihood" of the data set, is worsened a bit. This means that the model is less precise as a predictor of P(DCS) than it might be, although the discrepancy is slight. The compromise is judged as being justified by operational considerations. The tissue time constants in this compromise model are  $1.3 \pm 0.4$  min,  $136 \pm 15$  min, and  $1140 \pm 47$  min.

A real time computer algorithm incorporating the LE1 model with the compromise parameter values is currently being tested against experimental dives at NMRI, with the new dive data being used to augment the database. Testing will continue at the Navy Experimental Diving Unit in Panama City, Florida as we seek to "validate" the model in the U.S.N. sense of that verb. The algorithm using the finalized parameter values will be submitted for approval for use by the U.S. Navy fleet.

### Concluding Remarks

The logic behind using likelihood maximization to analyze the risk of dives and to predict acceptably safe schedules has been presented. What are the implications for the practices followed by AAUS members, particularly with respect to repeat dives?

First, it has been noted that we found no statistical argument to dissuade us from using the same models, with the same parameter values, to describe repeat dives as we do for single dives. In a real time computer algorithm both categories of dives would be treated equally; the diver would be instructed by the same algorithm during either sort of dive. Currently, a diving computer is the only way we have to generate repeat dive procedures. Because of mathematical complications, the models do not lend themselves readily to preparing tables of repeat dives schedules that a diver would plan *a priori*.

In considering the practices of AAUS divers, there is a real problem with applying the NMRI results. The sorts of exposures to which sport divers, divers in archaeological expeditions, oil rig workers, etc. are subjected are far different from the exposures that went into the database upon which the NMRI study is based. Generally, they are substantially shorter and/or shallower, and consequently safer, than the dives against which our models are calibrated. Should we extrapolate the results of the NMRI work to make predictions about this fundamentally different set of exposures? If the models were known to be comprehensively accurate then one should have no qualms about calibrating them against any carefully assembled data set and then extrapolating them to cover any other sort of dive, but, unfortunately, that is not the case.

Rather, we must seek to collect good data on DCS incidence in such relatively safe exposures and then apply models and the likelihood maximization technique to analyze these exposures. The task is daunting since the low incidence of DCS in such relatively safe dives, on the order of 0.1% or less on the evidence of talks presented at the latest AAUS workshop, means that huge numbers of dives must be meticulously recorded in order to gather a quantity of information that would permit meaningful statistical analysis. When that is accomplished then we can perform the work that will put the formulation of low-risk diving procedures on a good scientific footing and dispense with the guesswork and reliance on religious faith that characterizes current practice.

### Acknowledgements

The use of maximum likelihood analysis of decompression sickness was initiated at NMRI by Paul Weathersby, Shalini Survanshi, and Lou Homer. Much of the results in this paper are due to Randy Hays, Jennifer Parsons, and Erich Parker.

### References

- Albin, G.W. and P.K. Weathersby. In prep. Statistically based decompression tables VI. Repeat dives on oxygen/nitrogen mixes. Naval Medical Research Institute Technical Report, Naval Medical Research Institute, Bethesda, Maryland.
- Edwards, A.W.F. 1972. Likelihood (An account of the statistical concept of likelihood and its application to scientific inference). Cambridge, U.K.: Cambridge University Press.
- Lauckner, G.R., R.Y. Nishi and B.C. Eatock. 1984. Evaluation of the DCIEM 1983 decompression model for compressed air diving (Series A-F) DCIEM Report 84-R-72.
- Lauckner, G.R., R.Y. Nishi and B.C. Eatock. 1985. Evaluation of the DCIEM 1983 decompression model for compressed air diving (Series L-Q) DCIEM Report 85-R-18.
- Nishi, R.Y., B.C. Eatock, I.C. Buckingham and G. Masurel. 1981. XDC-2 digital decompression computer: assessment of decompression profiles by ultrasonic monitoring, Phase II:30-75 msw. DCIEM Report 81-R-02.
- Nishi, R.Y., B.C. Eatock, I.P. Buckingham and B.A. Ridgewell. 1982. Assessment of decompression profiles by ultrasonic monitoring. Phase III: No-decompression dives. DCIEM Report 82-R-38.
- Nishi, R.Y., G.R. Lauckner, B.C. Eatock and J.T. Hewitt. 1984. Oxygen decompression techniques for compressed air diving using the XDC-2 decompression computer programmed with the Kidd-Stubbs 1971 model. DCIEM Report 84-R-19.
- Nishi, R.Y., K.E. Kisman, I.P. Buckingham, B.C. Eatock and G. Masurel. 1980. XDC-2 digital decompression computer: assessment of decompression profiles by ultrasonic monitoring, Phase I: 36-54 msw. DCIEM Report 80-R-32.
- Novotny, J.A., D.L. Mayers, Y.F. Parsons, S.S. Survanshi, P.K. Weathersby and L.D. Homer. 1990. Xenon kinetics in muscle are not explained by a model of parallel perfusion-limited compartments. *J. Appl. Physiol.* 68: 876-890.
- Thalmann, E.D. 1984. Phase II testing of decompression algorithms for use in the U.S. Navy underwater decompression computer. Navy Experimental Diving Unit Report No. 1-84, Navy Experimental Diving Unit, Panama City, Florida.
- Thalmann, E.D. 1986. Air-N<sub>2</sub>O<sub>2</sub> decompression computer algorithm development. NEDU Report 8-85.
- Thalmann, E.D., I.P. Buckingham and W.H. Spaur. 1980. Testing of decompression algorithms for use in the U.S. Navy underwater decompression computer. Phase I. NEDU Report 11-80.
- Weathersby, P.K., B.L. Hart, E.T. Flynn and W.F. Walker. 1987. The role of oxygen in the production of human decompression sickness. *J. Appl. Physiol.* 63: 2380-2387.

Weathersby, P.K., L.D. Homer and E.T. Flynn. 1984. On the likelihood of decompression sickness. *J. Appl. Physiol.: Respirat. Environ. Exercise Physiol.* 57: 815-825.

Weathersby, P.K., S.S. Survanshi, L.D. Homer, B.L. Hart, R.Y. Nishi, E.T. Flynn and M.E. Bradley. 1985. Statistically based decompression tables I. Analysis of standard air dives: 1950-1970. Naval Medical Research Institute Technical Report No. 85-16, Naval Medical Research Institute, Bethesda, Maryland.

Weathersby, P.K., S.S. Survanshi, L.D. Homer, E. Parker and E.D. Thalmann. In press. Predicting the time of occurrence of decompression sickness. *J. Appl Physiol.*

**Data Analysis & Procedure Calculation Session Discussion**

R.W. Hamilton, Moderator

- J.P. Imbert: Has anything been used to separate between Type I and Type II DCS and what were the results?
- M. Gernhardt: Well, I can tell you what we are doing at the moment. We are not making any distinction between the severity or type of bend. It is admittedly very crude on our part, but the best we do is to say that a person at some point after a profile has had DCS or he has not, that is all.
- G. Albin: We are only recognizing three possible outcomes, 0, 0.1 or 1, so we are not modeling using a difference between Type I and Type II bends.
- J.P. Imbert: But, considering the fact that you already made differences in the type of decompression - you mentioned that oxygen breathing was poorly fitting the data - it could be useful perhaps.
- G. Albin: We have only a very small data set that includes oxygen decompression; it is not that they fit poorly, it is just that they need a different set of parameter values than the rest of the dives in our data set. Physiologically, we cannot make any sort of conclusion.
- J.P. Imbert: Using the risk prediction model, is it possible to find the limits to diving, especially to surface decompression diving, assuming that the recompression in a chamber is limited to 12 meters? Does it support the memo from the DEN in the North Sea?
- M. Gernhardt: We have analyzed all of the tables that are presently in use in the North Sea and find that the predicted decompression stresses do increase with increase in exposure index. We have also shown that with different decompression procedures, it is possible to attain the same level of decompression stress associated with PrT values of 25 by doing much longer bottom time exposures, but with a better quality of decompression. So, the answer is that with existing procedures, it looks like limiting time and depth would reduce DCS incidence, but that it is possible, we think, to develop new procedures that can allow longer bottom times with the same level of decompression stress.
- J.P. Imbert: When you said quality of the decompression, do you mean the length of the decompression or the depth of the chamber recompression?
- M. Gernhardt: Several things. One, as I alluded to, increased water stop time can actually be counterproductive. It can result in greater decompression stresses during the surface interval. By improving the way that you decompress to the surface, prior to recompressing in the chamber, you can reduce stresses there, and then by oxygen treatment in the chamber you can further reduce those stresses.
- K. Huggins: On the deep to shallow and shallow to deep repetitive dives that you did, I wonder if you would compare what the risks were? Which one came up with the calculated higher risk? In your test dives, did you find higher bubble grades in one of the series over the other?
- P. Tikuisis: In terms of which dive gave the highest risk, I can show that later. It would take me a few minutes to identify the actual dive that you are talking about. What I can tell you is that within the confidence interval there is no statistical difference. For the recommended repet air dives, although there was a reduced predicted risk, those were not significantly different from the tested dives.
- K. Huggins: With the different statistical models that you have - the two compartments, three compartments and various ways you are looking at it - is there any difference? Has anybody compared the different models together to see whether the general shape and duration are different between the models?
- P. Tikuisis: In some of the earlier work, in fact, this is what we did to tease out which model is the best predictor. One goes through various configurations and various parameters and thresholds. In fact, I even played with solubility factors when considering helium versus nitrogen, so there is no limit to what kind of model one does. The ultimate test, of course, is to maximize the value. The model that gives you the best value is the one you then use for predictive purposes; they do give different predictions. I have seen this in some earlier work where we went with several compartments in parallel versus two compartments in series. You will find differences.

- R. Nishi: I just wanted to amplify on Karl Huggins' questions. All those 92 man dives that were done on that reference that Peter showed were monitored with Doppler and, in general, there were not that many bubbles. But, the ones that had the most bubbles were the ones with the deep dive second. There were two dives that were 60 feet for 50 min followed by 50 feet for 75 min, which are on our no-D limits, and they produced grade three bubbles in several subjects.
- G. Albin: In general, in doing the parameter estimation, you start with the simplest model and eventually or gradually work your way along, adding more and more parameters. You ask yourself at each point as you go to a more complex model with more adjustable parameters, do you get a statistically significant improvement in the fit to the data?
- W. Gerth: There is another issue that complicates things. Any model that you try to fit to data has a certain number of parameters in it. The model that is able to handle a wider variety of conditions is going to have a wider scope; it is going to require more adjustable parameters. The problem in determining the values of those parameters and fitting the number of parameters you can handle in a fit routine for which you can actually come up with a number depends a lot on the number of DCS cases in the data set. We get very large data sets with a large number of man-dives in them, but the bends rate is only 5 percent. That allows us to put hard numbers on it. Dave Southerland has a rule of thumb: You need a minimum of five times the number of decompression hits in a data set as the number of parameters you are trying to fit. So, if you have five parameters, you have got to have at least 25 hits in that data set. The more the better. If you have a huge data set with no hits in it, it does not do you any good. We are working with data sets that may be very large, but the incidence rates are really rather low and that limits the scope of the models. That is why we end up having models that are sort of customized for the particular application by the way they are tuned to the data sets we use.
- R. Eckenhoff: With regards to the treatment of the marginal cases it makes good sense to include those somehow. Initially, Paul Weathersby was including them as 0.5. I am wondering why the minimization to 0.1?
- G. Albin: We were getting a much higher prediction of the risk of a 20 foot saturation dive than we thought we should. It was being predicted as having 10 percent risk. I mentioned that our model was predicting that you could not finish most dives with a 20 foot saturation or with a 20 foot stop and not a 10 foot stop and still retain acceptable risk for that dive. That is related to the high risk that was being predicted for the 20 foot sat dives. We know from the data that the 20 foot sat dives have a much lower risk than 10 or 15 percent. The model is not going to fit an entire data set equally well. In fixing that, we saw that many of the DCS cases listed in our saturation dive data set were marginal DCS cases. Instead of counting those as 0.5, we counted those as 0.1, then the model would think those were more reliable and might bring down the predicted risk of all the saturation dives, including the 20 foot saturation dive. As far as I know, nobody knew or could think of any good reason why it should be 0.5 or 0.1, or for that matter most any other number between zero and one.
- M. Emmerman: For clarification, M. Gernhardt stated that the long deco hang could make the surface decompression worse. For those of us in the recreational and scientific communities, we tend to do long hangs at the end of repet groups and burn off air in the shallows. Were you referring to those kinds of dives, or to more extreme exposure dives?
- M. Gernhardt: No, the comment was only directed toward surface decompression where you do some limited amount of decompression in the water and then ascend in a supersaturated state to the surface, followed by recompression. The long burn-off times for in-water decompression associated with sport or scientific diving would be predicted to be more conservative.
- J. Lewis: It sounds like for the first time someone is trying to, in some systemic way, have a feedback loop that gives us a more comprehensive description of what is going on. But, what kind of confidence can I place on trying to extrapolate from 5% to 0.0001%? Somehow it does not seem like that is the order of magnitude that one can feel comfortable with. But, when I try to take it to

- recreational diving where our experience is 1 out of 10,000, and the scientific community 1 out of 100,000, if I said something about the statistics, can I do that with confidence?
- W. Gerth: In any given fit, we can calculate confidence limits using rigorous statistical techniques. Peter showed some of those that he has calculated for his fits, in the terms that you are describing. Those are really rather wide, but when we are able to achieve that numerically, we are pretty happy.
- J. Lewis: No, when I said with confidence, I was not speaking from a "confidence level" of the statistics. What kind of confidence can I have that I can extrapolate what you are doing down to recreational diving, where my objective is one out of 10,000 or better (in terms of the incidence of decompression sickness)?
- G. Albin: We feel that the models are entirely empirical and they can only be trusted in those regions where they have been fitted to actual data. We would not try to extrapolate them to any other type of data. They do not even fit all of the data well that they have been calibrated against. We would have very little confidence in using anything predicted by this means.
- J. Lewis: I listened with interest to the three time constants and I assume that they have something like half-times, 1.3, 136 and 1140 minute? Are they based on Haldanian uptake or something? I was just curious as to what kind of a no-decompression limit you could get out of those. They look pretty strange relative to what we are accustomed to using. For example, the 1.3 minute cannot do anything other than try to get a no-decompression table out of a single 120 minute compartment, which is a pretty good trick.
- G. Albin: The calculation, though, is altogether different in this case. We are not looking to limit the over-pressure to some maximum during the dive. We are accumulating what we call "risk" throughout the dive, and then we are converting that accumulated risk to some probability of DCS through the dive. For a no-decompression limit, we would say arbitrarily that we do not want the total risk to be higher than 2 or 3 percent. We would choose our depths and times such that we would get 2 or 3 percent.
- J. Lewis: But, if you set 2 percent as a goal, what would be the no-decompression limits?
- G. Albin: We have tabulations for that; I cannot tell you now.
- J. Lewis: It would be a little strange, I would suggest.
- W. Gerth: No, I can rattle a number off. From the model calibrated with the data set we used which incorporated the Des Granges standard air tables, we get 71 minutes at 60 feet of fresh water.
- P. Tikuisis: These time constants are not to be treated in the same way as I think you are suggesting. They are "gain" factors that are attached to each compartment, and while the time constant may be short for one particular compartment, its gain factor is going to play an important part in how it contributes to the risk.
- J. Lewis: So, it is not fair to assume that it would be the typical Haldanian model?
- W. Gerth: That is correct, all compartments are not treated equally. With Gary's three compartments even the first two compartments did not have a threshold value, the third one did. Each compartment, even though they may appear to be similar, has its own characteristics.
- S. Survanshi: I could answer the question about only using three compartments and whether we get bizarre no-D limits. We do not. In fact, that is one of the ways we measure our model, by asking what the no-D limits at various depths would be at the 1%, 2%, 3% and 4% level. For instance, we use 60 fsw for 60 min as the current Navy limit, and find out for 60 for 60 exactly where we put it. Do we put it at two percent or do we put it at a three percent? We find the current Navy tables and even no-D limits are not iso-probabilistic. Shallow dives end up being less risky. The deeper dives, which we already know, are much riskier. Your eventual aim may be to not propose iso-probabilistic tables, but to match them to the diver's expectations for shallow dives or short dives. Where there are more dives happening, we would want to propose "no-risk" tables, whereas the ones that are done less often and where there will be a medical officer present, we might want to propose a little riskier tables and still keep the decompression time to an optimum limit. However, we do check our models against the current limits to see exactly what we propose. If they look bizarre, obviously the model is not doing too well, because our current experience has already given us a certain type of data.

J. Lewis: So, the answer is that the probability which you assign is depth dependent.

S. Survanshi: Our data probably says that. We will always go back to the data. Current Navy tables do not necessarily provide equal risk data.

J. Bozanic: If you are designing tables that are treating this as equal risk, do we want to set forth rules for the scientific and recreational communities that look at dives as non-equal risk? In other words, set some kind of parameter that would say you should not make a dive to a depth that is more than five times the bottom time, *i.e.*, limit the short deep dives that have a higher risk associated with them? The second question I have is for Gary. You had mentioned that the dives that you were doing for both single and repetitive dives using a variety of nitrogen/oxygen mixtures fit your risk data well. Is that normalized using some kind of "equivalent air depth" concept, in fact validating that kind of an EAD concept for use of other nitrogen/oxygen mixtures?

G. Albin: There is no normalization involved here that I can think of. We use the models the way I described, and we attempt to fit the models to our data by adjusting. We have an algorithm that systematically adjusts the adjustable parameters in the model. We have found that you could throw together a group of single dive data and a group of repet dive data into the same data set and fit the model to those, get the parameters adjusted, and get just about as good a fit to the overall data set as you would get to the single dive data set alone, or the repet dive data set alone. In other words, the model is global. The models behave well globally with both single and repet dives. It is just an empirical thing, so we conclude from that that repet dives are not from some different population than single dives with respect to our models and we use the same models for both.

R. Hamilton: Gary, you mentioned that it handled repet dives okay, but you said that it did not handle oxygen and multi-level well. Oxygen can be due to a bunch of unrelated physiological factors, but multi-level dives seem to me like dives with conservative decompression, and I do not understand why it does not handle them.

G. Albin: You can look at the way the models behave with multi-level dives and you can figure out mathematically why you need different parameter values with multi-level dives than you do with the other dives.

R. Hamilton: What is the difference between a multi-level dive and a dive with a strange decompression?

G. Albin: Maybe I should have defined this earlier. By multi-level dive, I mean one where the diver ascends to some depth, not to be zero, one or more times during the dive profile. For example, go down to 100 feet, come up to 20 or 30 feet for a while, then go back down to 100 or 120 feet.

R. Hamilton: That is a different kind of dive; some folks call that a "continuation" dive or a "yo-yo" dive.

G. Albin: Was that confusing? That is what Ed Thalmann told me a multi-dive was.

M. Lang: All right, with that issue resolved, I do want to reiterate the first risk parameter question that Jeff Bozanic posed, and see if we can address that for scientific and recreational diving.

J. Bozanic: The question was, where we have some indication that some particular dive profiles have associated with them a serious decompression incidence, do you want to set forth a rule or look at the generation of a model or table that would take those dives into account, modifying the practices of the sports diving and scientific diving community with regard to those dives?

W. Gerth: If you are going to put forth a table to be used by a certain population, then certainly you have to make a judgment about what risk you choose in developing that table. If you develop a real time schedule on the basis of real time data, it can provide you a whole array of risks for your next safe ascent depth, depending upon how long you have been at the current stage. It can be a fluid thing that you can construct if you or the table builder have enough information to make that decision about acceptable risk. Are you asking us to say what sort of risks we should use here and what sort of risks we should use for another sort of application?

J. Bozanic: Not necessarily. Application perhaps to the type of diver. We have a community of people who do not necessarily look at the risk that is associated with the particular dive profiles. The tables that are currently available do not address that issue. Yet, we have serious DCS with a particular type of dive. Should there be some kind of recommendation for bounce dives as opposed



- to a repetitive dive or a single dive? Some means of quantifying what qualifies as a short deep dive?
- R. Hamilton: Paul Weathersby (1986) has published a study of the U.S. Navy, the Royal Navy, and the DCIEM tables where he gives a risk estimate for each combination of time and depth.
- W. Sutherland: We are really talking about two different issues here. During yesterday's panel on scientific diving, I think it was agreed that we considered zero percent DCS as the only acceptable answer. You are talking about fitting models to a data set that has seven percent risk, correct?
- W. Gerth: We agreed from three to seven percent.
- W. Sutherland: In terms of answering Jeff's question, we really cannot apply any tables developed using these models to a scientific or recreational community because we do not accept the 7 percent risk used in your models.
- W. Gerth: The 7 percent risk is what the data set contains inherently. We have a line that we know at the outset has some lumps in it, and we try to get the shape of that line by setting it on a surface. If that surface by itself is flat (if the data set has a very low bends incidence) then we are going to get a flat line. But that is not what we are after. There have to be as many cases of decompression sickness in the data set as we can get, but that does not mean the model is good only for 7 percent. We can calculate a table with a risk that is very low on the basis of the data set in which we have a certain confidence in the predicted values.
- W. Sutherland: Was that not what John Lewis was asking? If you develop a table based on the data set that has 7 percent DCS hits, can you then take that table and extrapolate to get down to one in 10,000 and use numbers based on that extrapolation and dive those numbers?
- W. Gerth: Well, we feel very confident about things that have very low risk, but I do not know about one in 10,000. The uncertainty of the prediction is going to be within that range. We are able to say for a given profile the probability - on the basis of our model - of a bends hit in that profile. We can say that it is zero, but our confidence in that prediction may be from zero to 2 percent when the predicted value is zero.
- S. Survanshi: Maybe I can clarify the point. The average incidence in the data set is 7 percent, but this is on a wide range of dives. We have some dives that have a rating of 20 percent and there are low risk dives, as low as maybe 0.5 percent. The ideal is to get as wide a data set as possible so you have a complete range of levels within the data set. Then, along with the maximized likelihood number, you also do a second test in which you rearrange all of these dives by completed risk level. Then you take your low risk, medium risk, and high risk dives and observe very closely what they have predicted. That means your model could now be very close to the data in this next higher risk range, so even if the data set's overall incidence is 7 percent, you actually have a figure that is as low as 0.5 or 0.01, or maybe as high as 20 percent. Then you may have extra confidence in extrapolating. When you start extrapolating, then your confidence starts getting wide.
- J. Lewis: Interpolation implies between two points. We are talking about extrapolating, like two out of ten down to five out of a hundred, or down to one out of 10,000 or one out of 100,000. I can tell you the slightest variability between those two points is going to make a dramatic change. We are talking about orders of magnitude, not a few percent.
- S. Survanshi: No, these data are not going to give you good predictions of one out of 1,000 or one out of 2,000. It also could be that we are actually looking at two different data sets here. The laboratory data will be actually very different from what you have observed in real life. Lab data is where the medical officer is present at every single dive. With these deep depths, there has to be a medical officer present to find out if the diver is moving his leg a little funny, or even after he surfaces the medical officer is constantly checking the diver up to 24 hours. If that type of testing were applied in practice in civilian diving, we may find that they are not really the numbers. They may be actually one in 200, I don't know. So, the vigorousness of data is quite different in practice between recreational and commercial diving versus laboratory diving. You can't mix the data.

## DESIGN OF DIVE TRIALS

*Shalini S. Survanshi*

*P.K. Weathersby*

*L.D. Homer*

*E.D. Thalmann*

Naval Medical Research Institute  
Bethesda, MARYLAND 20889-5055

*Design of dive trials is a two part process, both of which can be helped by statistics. First we need to decide what schedules to test and then how to test them. Probability based models can help us select schedules with minimum decompression time at a chosen level of risk, for a given depth and bottom time. Once a schedule is chosen for test, a sequential trial design can minimize trial size and cases of DCS incurred while retaining statistical power of the trial. This paper compares sequential trial designs to conventional fixed rule trial designs and describes how an efficient dive trial could be set up.*

Two questions come to mind when we think of the design of dive trials. What decompression schedules should we test and how should we test them?

Our approach to the first question is to use probability based decompression schedules. Obviously, we are assuming that we already have a probabilistic model that has been fitted to a large data set containing a wide range of dives (Weathersby *et al.* 1984; 1985a). Such a model can then be applied in two different ways:

- 1) We can estimate probability of DCS,  $P(\text{DCS})$ , and a confidence region for any given dive profile; and
- 2) We can find a decompression schedule with minimum decompression time for any given dive (*i.e.* depth and bottom time) at a given level of  $P(\text{DCS})$  (Weathersby *et al.* 1985b).

The latter application is more interesting for us, since it gives minimum decompression time at a specified  $P(\text{DCS})$  level. This also can be applied to a repetitive dive profile. For specified depths, bottom times and surface intervals we can minimize decompression time while keeping  $P(\text{DCS})$  for the entire dive profile is at a given level. The question of which dives (depths, bottom times and surface intervals) to test has other practical implications which will not be discussed here.

Let us proceed to the second question of how to test the schedules. If we were to make a wish list for the testing phase, we would put the following three items on our list:

- 1) We would like to conduct a minimum number of test dives;
- 2) We would like to encounter a minimum number of cases of DCS; and
- 3) We would like to have clear answers at the end our dive trial.

Unfortunately, we get to pick at the most two items out of the three. For instance, if we want to keep the dive trial size and cases of DCS to a minimum, we may not get very clear answers. Or, if we want clear answers and want to keep cases of DCS to a minimum, we may have to conduct a rather large dive trial. With these constraints in mind, is there a good way to design a dive trial?

For any dive trial there exists a characteristic power curve as shown in figure 1 (Wald, 1947; Homer and Weathersby, 1985). The variable along the X-axis is the true probability of DCS for the schedule being tested, and the variable along the Y-axis is the probability that we will accept the schedule

being tested as a result of this dive trial. For instance, if the true probability of DCS for the schedule being tested were  $P_0$  or less as shown in figure 1, we would be reasonably sure that we would accept the schedule as a result of this dive trial. Or, if the true probability of DCS for the schedule being tested were  $P_1$  or greater, we would be reasonably sure that we would reject the schedule being tested as a result of this dive trial. To put it differently, if we conducted this dive trial and ended up accepting the schedule, we would be reasonably sure that the accepted schedule is not riskier than  $P_1$ . Conversely, if we conducted this dive trial and ended up rejecting the schedule, we would be reasonably sure that the rejected schedule is not safer than  $P_0$ . Alpha ( $\alpha$ ) and beta ( $\beta$ ), as shown in figure 1, are type I and type II statistical errors respectively. Again, alpha is the probability that we will reject a safe schedule as a result of this dive trial, and beta is the probability that we will accept an unsafe schedule as a result of this dive trial. The region between  $P_0$  and  $P_1$  is called the region of indifference. Obviously, one would desire a narrow region of indifference. A power curve then represents how clear our answers are going to be at the end of a dive trial. So if we somehow managed to get a power curve for a dive trial we are about to conduct, we would know how clear our answers are going to be ahead of time.

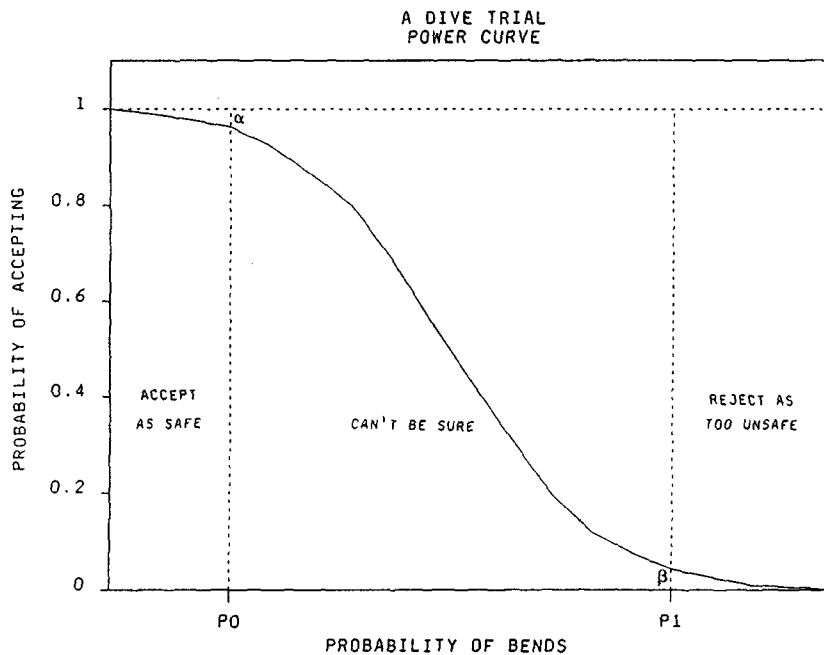

Figure 1.

How do the power curves for real dive trials look? Figure 2 shows power curves for three dive trials with three fixed trial sizes (fixed rule). The solid line (marked 2/40) represents a power curve for a fixed trial size of 40 where a dive schedule being tested is rejected if 2 or more cases of DCS occur at the end of 40 dives. (A "fixed rule" assumes that we are committed to conduct 40 dives regardless of number of cases DCS observed). The other two curves represent similar dive trials where the schedule is rejected if the observed raw DCS incidence exceeds five percent. The power curves get steeper as the trial size increases, *i.e.* the region of indifference gets narrower. These curves can be obtained by adding up binomial probabilities. For instance, the solid line can be obtained by adding up 0/40 and 1/40 binomial probabilities for any true  $P(\text{DCS})$  along the X-axis. These power curves show us how clear our answers are going to be if we conducted these dive trials.

Can we come up with some other alternative designs that will give us very similar power curves, retaining the clarity of our answers, but decreasing the number of dives we have to conduct? The positive answer is provided by a proper sequential trial design. Figure 3 shows an example of how a

sequential trial might be setup. The X-axis is the cumulative number of dives being conducted and the Y-axis is the observed total cases of DCS. We plot our dive trial progress on this graph. For instance, if we have done 10 dives and incurred one case of DCS, we would be in the "continue diving" region. Any time we touch or cross the top line, we stop diving and reject the schedule being tested. Therefore, according to figure 3, any time we get two cases of DCS, we stop and reject the dive schedule. We do not have to conduct all 40 dives. Conversely, on the right hand side is the acceptance line. For instance, for this specific sequential design, if we get zero cases of DCS out of 28 dives, we stop the dive trial and accept the schedule being tested. But if we incur one case of DCS in the first 28 dives, we have to continue diving until we complete 40 dives or get a second case of DCS. Figure 4 compares power curves for the sequential trial (circles) and the 2/40 fixed rule trial (solid line). It is obvious that the two power curves are very similar, which means we have not lost clarity of our answers. The dotted lines in figure 4 represent the expected number of dives we would be required do for each dive trial. Clearly, the sequential design reduces the trial size significantly. We end up stopping the dive trial early if the schedule is very safe (zero cases of DCS in 28 dives) or very risky (2 cases of DCS early on). Obviously, we have managed to reduce the trial size without changing the shape of the power curve.

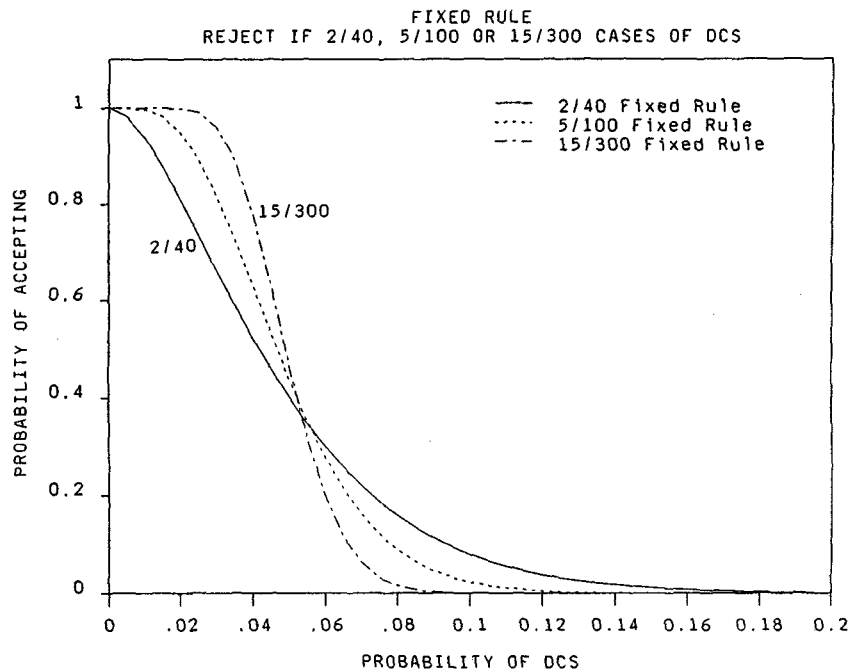

Figure 2.

How did we get the circles in figure 4? It is not as simple as adding the binomial probabilities anymore because there are several combinations of possible outcomes through which we may accept or reject a schedule. Therefore, we have to conduct a Monte Carlo simulation where we actually conduct a pseudo dive trial using a random number generator, and simulate thousands of dives to come up with the simulated curve. But, we can do that prior to starting our dive trial. We can experiment with the sequential design to see whether we can be more efficient in the trial size.

How can we apply this technique in practice? Let us assume that we want to design a dive trial for testing a schedule such that we want to make sure that the schedule is not riskier than 3% and we are not willing to incur more than 3 cases of DCS. The upper graph in figure 5 shows five different sequential designs. The top horizontal line is the rejection criteria (3 cases of DCS), and the vertical lines are the acceptance criteria for different trial sizes. The lower graph in figure 5 shows the five corresponding power curves and the vertical dotted line is our  $P(\text{DCS})$  level of acceptance. If we chose a trial size of 100 dives, the probability of accepting a risky schedule ( $P(\text{DCS}) > 3\%$ ) would be as high as

40% (Beta: type II error). For the trial size of 150 or higher, the beta error is significantly lower. If we decided that a beta < 20% is good enough, we could concentrate on a trial size of 150, and see if we can improve the trial design.

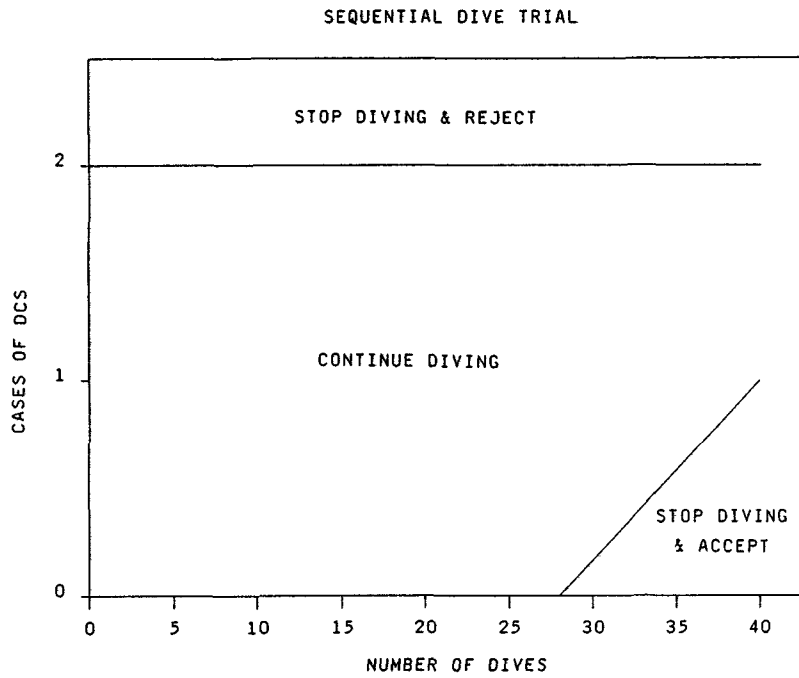

Figure 3.

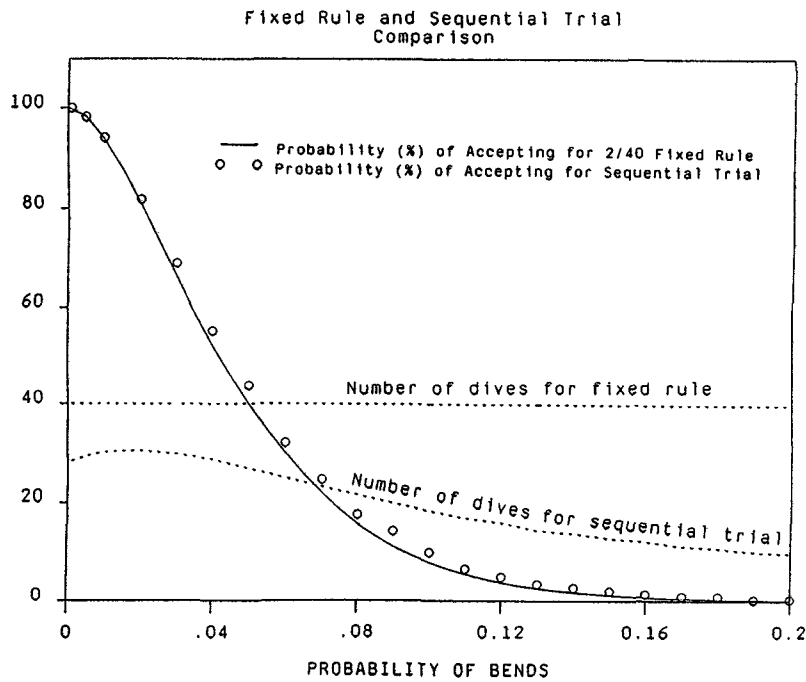

Figure 4.

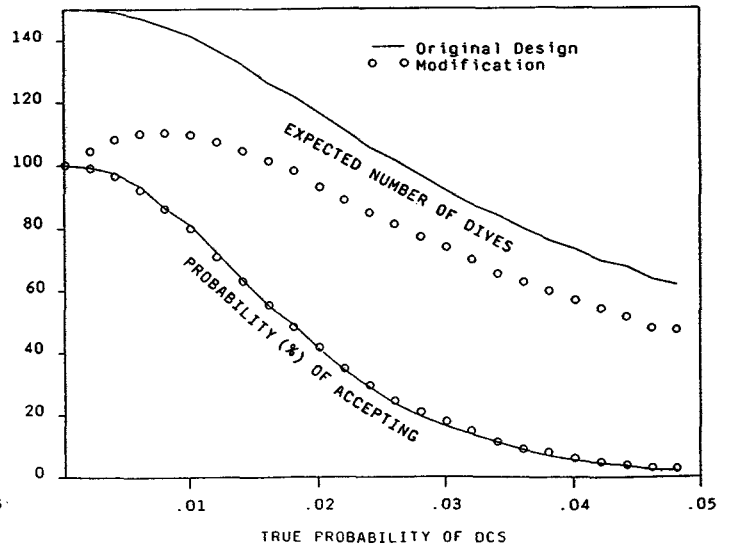
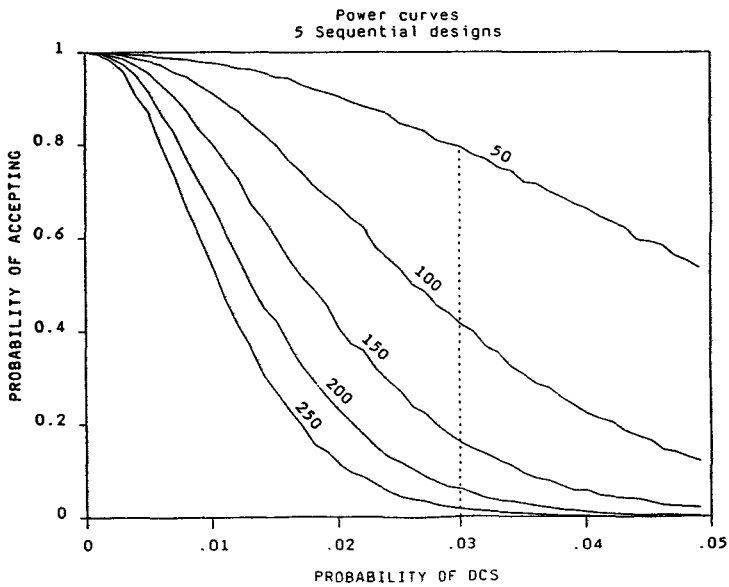
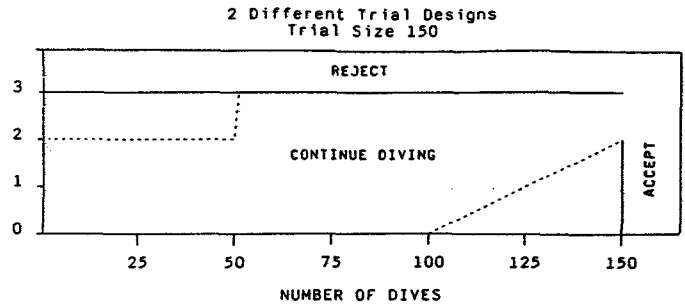
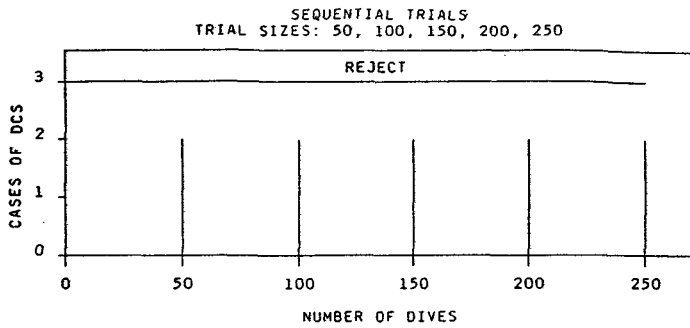

Figure 5.

Figure 6.

The upper graph in figure 6 shows modification to rejection and acceptance criteria in dotted lines while solid lines show the original simple design. According to the modified sequential design, we would stop the trial and reject the schedule early if we incurred 2 cases of DCS in first 50 or less dives (too risky). Similarly, we would stop the trial and accept the schedule if we incurred zero cases of DCS in 100 dives or one case of DCS in 125 dives (safe). The lower graph in figure 6 shows a comparison of power curves and expected number of dives. Again, the power curve shows the percent probability that we would accept the schedule against the true  $P(\text{DCS})$  of that schedule. The solid lines represent the original simple sequential design, while the circles represent the modified sequential design. Clearly, both power curves are similar, but we have managed to considerably reduce the expected number of dives we would have to conduct.

### Conclusion

Carefully chosen sequential designs can optimize trial size and cases of DCS while retaining statistical power of the trial.

### References

- Homer, L.D. and P.K. Weathersby. 1985. Statistical aspect of the design and testing of decompression tables. *Undersea Biomedical Research*, Vol. 12(3): 239-249.
- Wald, A. 1947. *Sequential Analysis*. John Wiley and Sons, New York.
- Weathersby, P.K., S.S. Survanshi, L.D. Homer, B.L. Hart, R.Y. Nishi, E.T. Flynn, M.E. Bradley. 1985a. Statistically based decompression tables. I. Analysis of standard air dives: 1950-1970. Naval Medical Research Institute Technical Report no. 85-16.
- Weathersby, P.K., J.R. Hays, S.S. Survanshi, L.D. Homer, B.L. Hart, E.T. Flynn, M.E. Bradley. 1985b. Statistically based decompression tables. II. Equal risk air diving decompression schedules. Naval Medical Research Institute Technical Report no. 85-17.
- Weathersby, P.K., L.D. Homer, E.T. Flynn. 1984. On likelihood of decompression sickness. *Journal of Applied Physiology: Respirat. Environ. Exercise Physiol.* 57(3): 815-825.

## SURFACE INTERVAL OXYGEN: RATIONALE AND STUDY DESIGN

*Thomas A. Fawcett*

*Richard D. Vann*

*Wayne A. Gerth*

Department of Anesthesiology

Duke University Medical Center

Box 3094

Durham, NORTH CAROLINA 27710 U.S.A.

*The use of oxygen (O<sub>2</sub>) as an aid to decompression has a strong physiological basis. Given the need for longer bottom times and reduced risk of decompression sickness (DCS), particularly with scientific diving, we undertook a study to evaluate the use of surface interval O<sub>2</sub> in repetitive diving. The application of a mathematical model for decompression risk and its use in designing repetitive dive profiles is described. Four test profiles using different depths and surface intervals were selected which maximized no-stop bottom time given a fixed theoretical risk of DCS. These profiles are currently under test in a dry chamber environment. Preliminary results are presented which show promise in the practical application of surface interval O<sub>2</sub> to increase repetitive dive bottom time. Future testing of this model in field trials is planned.*

### Introduction

The use of O<sub>2</sub> as an aid to decompression has its physiological basis in reducing the exposure to inert gas partial pressure and accelerating inert gas elimination. Gas partial pressures in arterial blood directly reflects the composition of the breathing medium. O<sub>2</sub> enriched breathing gas decreases inert gas uptake in tissues during hyperbaric exposure and augments inert gas elimination during decompression. Practical application of these techniques is utilized during O<sub>2</sub> enriched N<sub>2</sub>O<sub>2</sub> (nitrox) diving and the use of surface interval O<sub>2</sub>. The overall benefit of supplemental O<sub>2</sub> is to reduce the inert gas content of tissue.

### Methods

The first task was to determine quantitatively how O<sub>2</sub> affected the elimination of inert gas as it related to decompression sickness. For this purpose, we used a mathematical model of decompression developed at the F.G. Hall Hyperbaric Center as described by Gerth *et al.* (1991). This model employs three parallel perfusion limited tissues with a diffusion limited gas bubble in each tissue compartment (Figure 1). The risk of DCS is assumed to be a function of the largest bubble volume and follows a sigmoid dose response curve (Figure 2). The parameters of the model are optimized to an empirical database of dive trials using the technique of maximum likelihood. Following optimization of the model parameters, input into the mathematical model consists of ambient pressure, breathing medium composition and time. The model output is maximum bubble volume as a function of time which is related to DCS risk using the dose response curve (Figure 3). With this model, bottom times for repetitive dives can be calculated given an upper limit for DCS risk. For the purposes of this study, we



assumed a maximum DCS risk of 0.01% (1 in 10,000). The same model was used to develop the oxygen decompression schedules described by Fife *et al.* (1991).

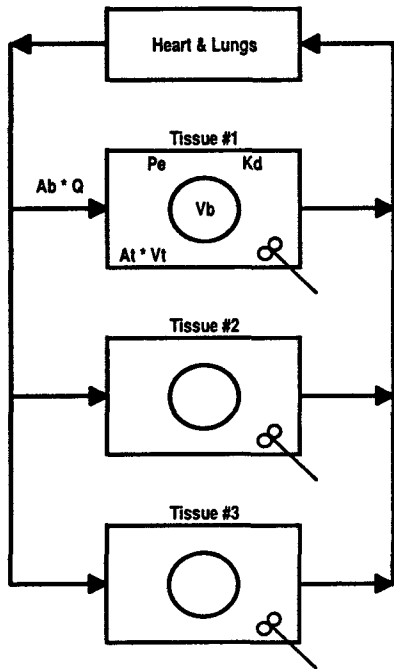

Figure 1. Decompression model.

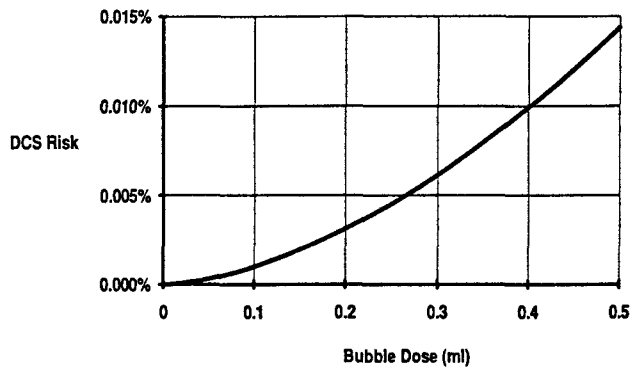
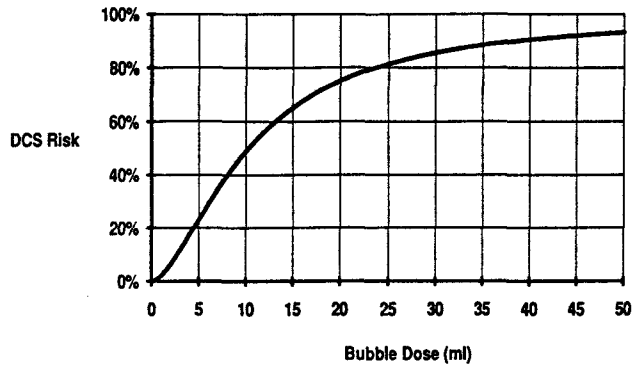

Figure 2. DCS probability as a function of bubble dose

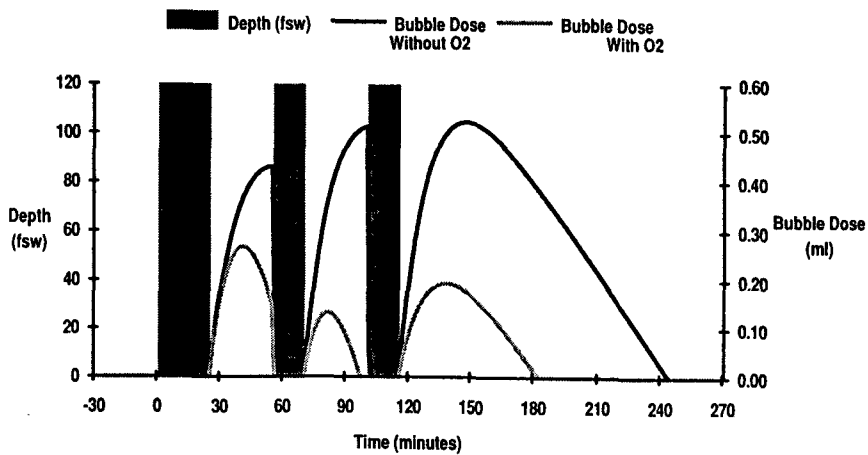

Figure 3. Decompression model predictions.

The dive profiles were designed for scientific diving where multiple repetitive dives to the same depth are common. The hypothesis was that 30 minutes of O<sub>2</sub> breathing during the surface intervals between repetitive dives will permit longer bottom times or earlier repetitive dives.

For scientific diving, common depths, gas mixes and surface intervals are 70 fsw with 36% nitrox, 120 fsw with 32% nitrox and surface intervals of 30 and 120 minutes. During the two hour surface interval, O<sub>2</sub> was administered during the last 30 minutes. The depth, inspired O<sub>2</sub> concentration and surface interval breathing media were input variables of the mathematical model and the maximum bottom times during three repetitive dives were determined for a DCS risk not greater than 0.01%. These calculations resulted in four test profiles as shown in Table 1 and Figure 4.

Table 1. TEST PROFILES

Profile	Depth	F <sub>I</sub> O <sub>2</sub>	Surface	Bottom Times			Number of Trials
			Interval	#1	#2	#3	
A	70	0.36	30	55	40	30	22
B	120	0.32	30	25	15	15	22
C	70	0.36	120	55	45	45	22
D	120	0.32	120	25	20	20	23

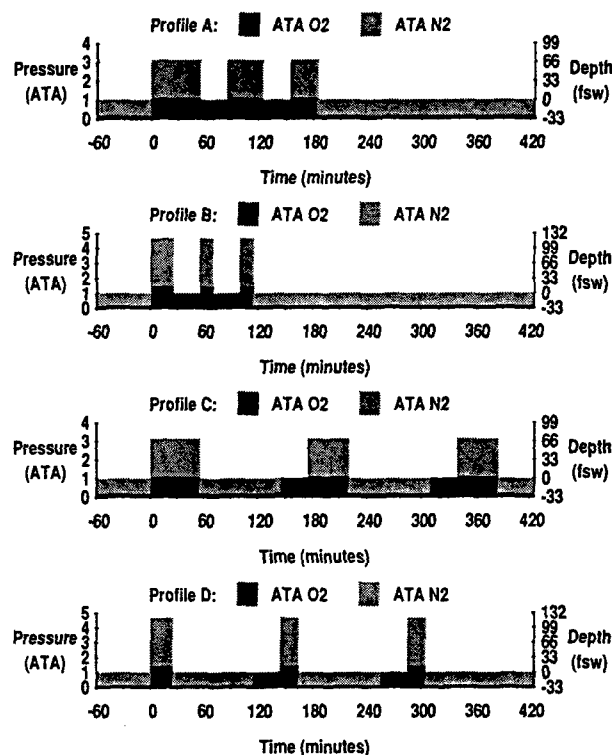

Figure 4. Repetitive dive test profiles.

Testing of these profiles was planned for two phases. Phase I involved trials in a dry hyperbaric chamber with resting divers and Phase II in-water field testing. In Phase I, there were 20-25 man-dives for each profile utilizing healthy, experienced volunteers. Subjects dived only once on each profile.

Given the small anticipated risk of DCS symptoms, decompression stress was also assessed by precordial Doppler bubble monitoring and measurement of blood complement activation (Ward *et al.*, 1990). Ultrasonically detectable venous gas emboli (VGE) reflect tissue inert gas burden and high Doppler grades are associated with increased DCS incidence. Doppler monitoring was performed prior to the dives as a baseline, during each surface interval and up to two hours following completion of the

profile. VGE, as detected by Doppler, was graded 0-4 independently by two individuals experienced in Doppler monitoring.

Activation of blood complement proteins was also measured to help quantitate decompression stress. Blood-gas interfaces activate the alternative pathway of the complement cascade with a resultant increase in plasma concentration of terminal protein fragments. Activation of the complement system may play a role in DCS susceptibility and acclimatization. Circulating levels of C5a appear elevated following decompression stress and pharmacologically decomplemented animals seem to be protected from DCS. Venous blood for complement assay was drawn from each subject prior to the dives as a baseline, upon surfacing from each dive and two hours following completion of the trial.

Possible pulmonary toxicity from O<sub>2</sub> breathing was evaluated by vital capacity measurements taken before diving and two hours following completion of the profile. Skilled hyperbaric personnel served as tender/subjects during each dive and were alert to the possibility of symptoms or signs of central nervous system O<sub>2</sub> toxicity. At least two weeks elapsed between testing of different profiles on the same individual. Subjects did not take chronic medication nor anti-inflammatory drugs during profile testing and female volunteers did not take oral contraceptives during profile testing and underwent routine pregnancy tests prior to each trial.

### Results and Discussion

The results of Phase I testing are encouraging. Profiles A, B and C have completed 22 man-dives and profile D, 23 man-dives. There was one pain-only DCS incident after the first dive of profile D (25 minutes at 98 fsw Equivalent Air Depth) before the use of surface interval oxygen. Only about 15% of the subjects have had detectable venous gas emboli, and these have been Grade 1 or 2 except for the one DCS incident where the bubble grade was 3. Preliminary analysis indicates no systematic change in blood complement activation levels during testing, and central nervous system or pulmonary O<sub>2</sub> toxicity was not evident.

The potential benefit of surface interval O<sub>2</sub> decompression to the scientific community is significant. Figure 5 shows test profile B compared to dives using maximum no-stop repetitive U.S. Navy air tables and standard NOAA nitrox or Equivalent Air Depth (EAD) tables. Neither the US Navy nor EAD tables permit repetitive dives in this time frame. Upon completion of Phase I chamber trials, in-water Phase II evaluation is planned to provide information as to the practical limitations of surface interval O<sub>2</sub> in the field.

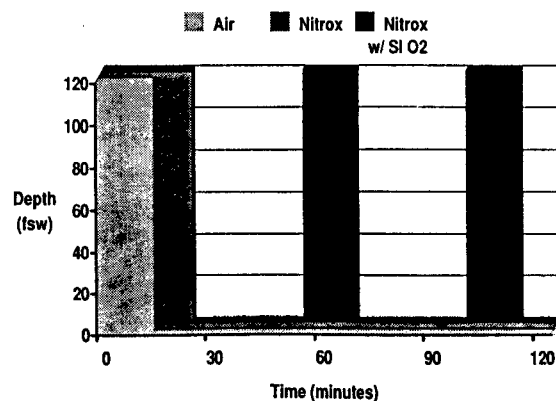

Figure 5. Comparison of surface interval oxygen with standard no-decompression tables.

An additional benefit of this statistical approach to decompression modelling is that changes in dive profiles may be quickly calculated to show decompression risk. For example, Figure 6 shows the estimated DCS risk for profile D compared to a similar profile with O<sub>2</sub> given in the first 30 minutes of the surface interval. O<sub>2</sub> breathing early in the surface interval reduces bubble size and DCS risk for the previous dive whereas O<sub>2</sub> breathing prior to a repetitive dive reduces bubble size and corresponding DCS risk for the repetitive dive. With computational modifications of the mathematical model, real time DCS risk also could be estimated which might be applicable to dive computers.

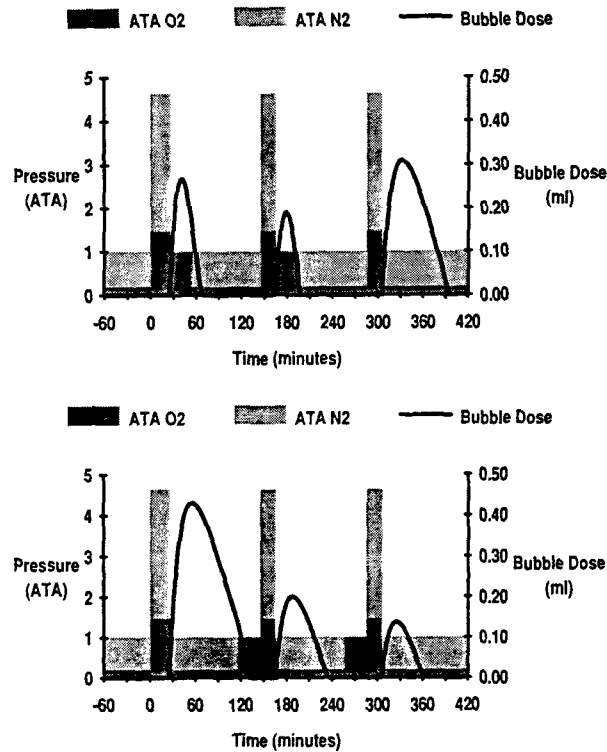

Figure 6. Model predictions for early vs. late surface interval oxygen.

### Conclusion

Surface interval O<sub>2</sub> appears to be an effective method for reducing decompression risk during no-stop repetitive dives. The use of a statistical mathematical model for decompression risk permits the incorporation of the beneficial effects of O<sub>2</sub> breathing into calculating decompression tables. The augmented inert gas elimination during surface interval O<sub>2</sub> breathing permits earlier repetitive dives while maintaining an upper limit on the risk of DCS. If this technique is validated, modifications could be made which would permit real time decompression risk assessment.

### References

Fife, C.E., G.W. Pollard, G.Y. Mebane, A.E. Boso and R.D. Vann. 1992. A database of open water, compressed air, multi-day repetitive dives to depths between 100 and 190 fsw. *In: Lang, M.A. and R.D. Vann (Eds.). Proceedings of AAUS Repetitive Diving Workshop. AAUS, Costa Mesa, CA. pp. 45-54.*

- Gerth, W.A., D.G. Southerland, and R.D. Vann. 1992. Quasi-physiological decompression sickness incidence modeling. *In: Lang, M.A. and R.D. Vann (Eds.). Proceedings of AAUS Repetitive Diving Workshop. AAUS, Costa Mesa, CA. pp. 253 - 262.*
- Ward, C.A., D. McCullough, D. Yee, D. Stanga, and W.D. Fraser. 1990. Complement activation involvement in decompression sickness of rabbits. *Undersea Biomed. Res. 17: 51-66.*

## DSAT DIVE TRIALS TESTING OF THE RECREATIONAL DIVE PLANNER

*Raymond E. Rogers*  
4020 Alvar Drive  
Pensacola, FLORIDA 32504 USA.

### Background

With increasing recreational diving came examination of whether increased dive time and increased safety could be compatible, and in this context, dive computers and new tables appeared. This paper discusses the testing of one of the latter, the Recreational Dive Planner (RDP) developed by Diving Science and Technology (DSAT) and distributed by the Professional Association of Diving Instructors (PADI).

J.S. Haldane devised decompression tables for caisson workers and military divers and he initiated a concept that persists in the collective psyche of the hyperbaric community, namely that those who are exposed to pressure should rely on a single decompression modality. Haldane's work was such a breakthrough that it did not seem to occur to anyone that it might be good to have differing tables for differing situations.

Caisson work involves relatively shallow but quite long exposures. It is non-repetitive by definition, and typically occurs over multiple days. Military diving uses tables designed for relatively deep exposures of short-to-medium length. It involves a limited amount of repetitive diving, usually not over multiple days. Recreational dives lie in between and represent a special case in that its exposures are far less severe than the prior modes. It is characterized by relatively shallow and short exposures with frequent repetitions, and which, increasingly, occur over multiple days.

Despite these differences, U.S. Navy tables became a *de facto* standard for recreational diving, not because of any particular suitability but for lack of a viable alternative and for lack of any perceived need to change. In time, growth of the recreational industry motivated the development of more suitable decompression methods. The proliferation of new systems made it self-evident that the U.S.N. tables were not preferred by recreational divers. The issue is whether any given alternative is adequate. PADI decided that an intensive test program would provide the best answer to this question.

Prior to adopting the RDP, PADI had several reasons to conduct a test program: 1) depth increments are smaller and time increments are not rounded off; decreasing "coarseness" but increasing bottom time, 2) multi-level diving is an integral part of the RDP and it was important to demonstrate its acceptability, and 3) the surface interval credit table is based on a 60 minute tissue compartment, appreciably increasing repetitive dive time relative to the Navy tables. A literature search provided little data to support the theoretical basis for these modifications, and it became obvious that new tables would require new research. Published data dealt with severe exposures, stage decompression, saturation diving, habitat exposures, mixed gas diving and virtually anything except no-stop diving. No detailed studies were found regarding frequent repetitive dives with short surface intervals which simultaneously restrict depth to 130 feet or less and which maximize bottom time without the use of formal decompression stops.

The Defence and Civil Institute of Environmental Medicine and the U.S. Navy Experimental Diving Unit have done a number of well publicized studies, but they were of little help. Every dive

that the NEDU did in the mid-50's was in excess of Wheel limits, and cannot be directly compared. In 1982, DCIEM reported 185 no-stop dives; of these, 123 were deeper than the recreational limit of 130 feet, and comparisons are of dubious value. Of those shallower than 130 feet, only 20 were brief enough to fall within Wheel limits (few bubbles, no DCS). In 1984-85, DCIEM reported a complex series of dives that included 169 air no-stop and repetitive dives; of this total, 104 were deeper than 130 feet. Of those shallower than 130 feet, only 16 were brief enough to fall within Wheel limits (no bubbles, no DCS). NEDU Reports #11-80 and #1-84 describe 673 dives, each beyond RDP limits and beyond direct comparison. NEDU Report #8-85 describes 661 air dives, each beyond RDP limits and beyond direct comparison. Even so, the available data was useful: the reports described dives that produced bends and bubbles, and they were helpful in indicating areas to avoid.

The literature was beneficial in showing the correlation between Doppler bubble grades and DCS. Even though these studies described diving with wide variations in character, there was a common trait: Grades 0, 1, and 2 had low DCS rates, while Grades 3 and 4 had sharply higher DCS rates. If the data of these early reports are combined, a graph shows a dramatic transition after Grade 2, where the DCS rate increases markedly. (Figure 1) In evaluating decompression stress of dive profiles, Doppler technology provides a degree of sensitivity superior to the mere presence or absence of DCS.

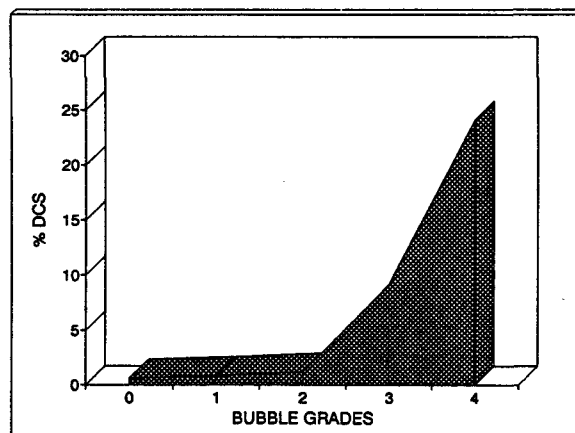

Figure 1. Decompression sickness as a function of bubble grades, composite of data.

### Phase I

DSAT was organized for the purpose of implementing the necessary investigations, and series of conditions were established. Every test would be for a greater amount of time than permitted by the RDP. Emphasis was placed on schedules which had the greatest time differentials compared to the Navy tables. Profiles would span the entire depth/time domain of recreational diving. Doppler monitoring would be an essential element of test evaluation, but the primary criterion of success was that no DCS would occur, and, secondarily, that only minimal bubbling would occur.

The Principal Investigator was M.R. Powell, then of the Institute of Applied Physiology and Medicine in Seattle, who utilized this system of scoring bubble grades (Table 1).

The program now called Phase I has been reported in Doppler Ultrasound Monitoring of Gas Phase Formation Following Decompression in Repetitive Dives, and this is a brief summary of that program.

There were a total of 911 dives made, 518 in chamber and 393 in open water. The test subjects were volunteer recreational divers, 70% male and 30% female. They represented all ages and degrees of physical fitness (Table 2).

Table 1.

Grade 0	No bubbles in at least 10 cardiac cycles
Grade 1	Occasional bubbles in 10 cycles
Grade 2	2 - 4 bubbles in some cycles
Grade 3	Several bubbles in every cycle
Grade 4	Bubbles are heard continuously

Table 2.

Age	32.8 ± 7.8	( 21 - 63 )
Weight (kg)	75.4 ± 28.6	( 47.7 - 113.6 )
% Body fat	23.1 ± 5.3	( 13.0 - 46.7 )

There was a wide variation in dive profiles, which were designed to test repetitive diving, both single level (square) and multi-level. Every dive for at least two depths, and most were for repeated exposures within the same profile. Tables allow less dive time than the models which generate them. The selected profiles "split the difference" and were longer than permitted by the RDP to increase the rigor of the trials (Appendix A).

Table 3.

Grade 0:	92.6%
Grade 1:	6.3%
Grade 2:	0.8%
Grade 3:	0.5%
Grade 4:	0.0%
DCS:	None

Following every compression, each subject was periodically monitored with Doppler probes, after rest and after knee bends. The bubble score was the highest recorded after each compression. Sessions were taped for later confirmation. Table 3 lists the results.

It was concluded that the criteria for success were met. Inasmuch as the U.S. Navy tables require decompression stops for every dive in the series, it was demonstrated that, within the tested parameters, a faster responding surface credit table is acceptable. It was also concluded that the results of multi-level procedure testing were satisfactory.

Although operational rules of the RDP require safety stops and long surface intervals on occasion, they were not used in the test program. Adherence to these rules makes routine use of the RDP more conservative than as tested. They were developed to recognize that tissue compartments slower than 60 minutes can exceed their limits during repeated long, shallow dives, and exhaustive computation determined two simple rules to address this situation. One is if you are planning 3 or more dives in a day beginning with the first dive, if your ending pressure group after any dive is W or X, the minimum surface interval between all subsequent dives is 1 hour, and the second is identical except that the groups are Y or Z with a 3 hour interval. The rules provide time for slower compartments to off-gas before another descent.

When first calculated, they seemed relatively unimportant, but it was well that they were in place. In the several years that passed during development and testing of the RDP, vacation diving gained great popularity and multi-day, repetitive diving is now widespread. The safety record of most resorts and live-aboard boats was generally good, but little was known about a potential accumulation of gas in theoretical compartments with long half-times. There was concern that normally safe dives could become dangerous by sheer repetition. Since there had been no significant studies of multi-day diving, data was scarce. These concerns were essentially speculative in nature, but to be on the safe side, this precaution was printed on the RDP: "Note: Since little is presently known about the physiological effects of multiple dives over multiple days, divers are wise to make fewer dives and limit their exposure toward the end of a multi-day dive series". Plans were made to begin a new phase of research.



### Phase IIa

When the multi-day series was first discussed, it was proposed to DSAT (not by DSAT) that the study should include 6 dives per day. Profiles were prepared and test protocols were drawn. In this process, a clause appeared in the protocols that was obscure and unnoticed by the principals. The provision said: "The test series for all subjects will end when any one subject displays evidence of decompression sickness". Unfortunately, one subject did experience DCS, in a knee which had been severely injured in a motorcycle accident several years previously. He was treated successfully, and the tests proceeded until someone remembered the protocol. The other three subjects were doing well, even though higher bubble grades were shown, and they desired to go on, but there was no latitude for judgement or decision. The series was thus ended abruptly and inconclusively, and it was necessary to determine how to begin anew. The co-sponsoring national safety organization said 6 dives per day could be reduced, reasoning that 4 rigorous dives per day were surely sufficient. The overly rigid protocol was modified to permit reasoned medical judgement, and testing resumed.

### Phase IIb

The format simulated the sort of diving that might be performed at a resort: two dives in the morning, one in the afternoon, and one at night. All the safety precautions imprinted on the Wheel were incorporated in test profiles, which were selected to provide a wide range of depths, and combinations of depths. As before, both single-level and multi-level dives were performed, and were arranged randomly to mimic real situations. Since the primary concern was how nitrogen might accumulate over time, emphasis was placed on dives that cause these gradual build-ups, namely long and shallow dives. Each day's tests spanned about thirteen hours, with each dive to the limit of the Wheel, except for the final daily dive, which was a shallow "square" dive of about 1.5 hours. (Appendix B)

The test consisted of 4 dives per day for 6 consecutive days using 20 subjects, for a planned total of 480 dives. Incidental ear squeezes reduced this number to 475. The subjects included 12 men and 8 women. The group was somewhat more fit than the Phase I group, but they were still not young athletes. Table 4 lists their characteristics:

The procedures for Doppler monitoring were as in Phase I, with results given in Table 5.

Table 4.

Age	Male	39.08 ± 11.62	( 21 - 61 )
	Female	36.38 ± 7.76	( 24 - 45 )
Weight (kg)	Male	78.30 ± 14.62	(59.1 - 111)
	Female	61.50 ± 7.96	(50.0 - 75.0)
% Body fat	Male	20.54 ± 5.90	(15.5 - 36.0)
	Female	26.74 ± 5.28	(21.6 - 35.3)

Table 5.

Grade 0	90.5%
Grade 1	4.6%
Grade 2	4.4%
Grade 3	0.8%
Grade 4	0.0%
DCS	None

A primary purpose of the multi-day trials was to learn whether repeated recompressions could be hazardous, causing a trend of increasing bubbles to develop through the week. Doppler data suggests that such a trend did not occur (Figure 2). An increase through a day did seem evident, confirming intuitive expectations (Figure 3). Overall, the total of bubble counts was low, and accumulations seemed to be at tolerable levels.

A relationship exists between the results of this study and those which were noted earlier: the sharp break in the DCS rate curve elicited from the other Doppler research correlates precisely with the end point of bubbling in the DSAT tests (Figure 4). The reasons for this greater success are speculative, but the probabilities are that it was because the DSAT exposures were far less severe than

in other trials, and because routine safety stops and long surface intervals were made whenever operational rules required.

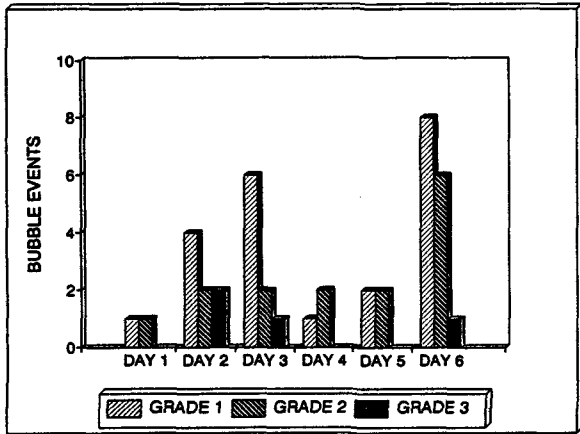

Fig. 2. Distribution of bubble events by days.

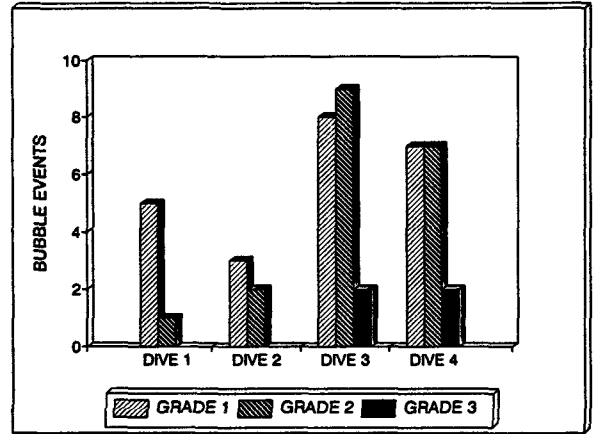

Fig.3. Distribution of bubble events by dives.

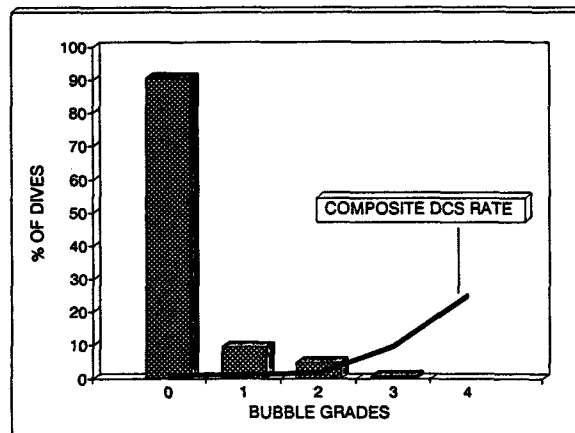

Fig. 4. Comparison of Phase IIb bubble grades and curve from composite of earlier data.

### Phase III

Suggestions have been made that multi-day water trials be conducted, and proposals are currently being discussed. As before, divers will be evaluated by Doppler ultrasound. Unlike before, the tests will be performed in fresh water. One of the largest problems with planning open-water trials that would last for days is the chance that bad weather could force an early end to a series. This dilemma may be solved by conducting the trials in water that has constant conditions (making suitable corrections for reduced density). Tests would be conducted in the 70 degrees F water of Wakulla Springs south of Tallahassee, Florida, which is deep enough to accommodate the recreational limit of 130'. The shore of the springs is very near to deep water, simplifying logistics. Redundancy is planned throughout with respect to personnel, equipment and safety procedures. A series of contingency plans should avoid the confusion related to the termination of Phase IIa.

As intuition suggests, the highest bubbles grades have been associated with the highest pressure groups. Efforts will be made to evaluate profiles across a range of surfacing pressure groups, but emphasis will be placed on dives which finish in very high groups. Bubble incidence and estimated risk as determined statistically by maximum likelihood methods will be evaluated for each repetitive dive group tested to assess the degree to which multi-diving should be tolerated or limited. The concept of adaptation to decompression stress has been widely accepted but as resort diving grew, concern grew that "sensitization" is a more likely outcome than adaptation. Even though Phase IIb data suggests that a week-long gas accumulation is not as great as feared, the issue is still debatable, and water trials might help to resolve it.

The bottom time provided by recreational tanks is frequently less than the no-stop limits at shallow depths. Air supply is unlimited in chamber trials, but can be the determinant of dive duration in open-water testing. A departure from earlier phases would be limitation of bottom time to the air consumption data in Table 5-3, U.S. Navy Diving Manual. Assuming divers use air @ 18 lpm swimming @ 0.5 knots, twin-72's @ 2250 psi allow dives of 35/75, 40/70, 50/60 and 60/55. Greater depths would be limited by the RDP.

Two separate areas of interest are being considered. The first is a series similar to the Phase IIb tests, with eight subjects making four dives per day for six days and with a new group beginning in each of four weeks. The second would compare four square and four multi-level profiles on a single day basis, also involving eight divers per day and four weeks of trials. Each profile would be tested 32 times, for a total of 1,536 dives. A different approach to profile selection would be employed in the first of these studies. A semi-factorial design was used to generate all possible four dive combinations of three depths (130, 70 and 35) in conjunction with three surface intervals (20, 90 and 180). All profiles which involved deep repetitive diving and shallow-to-deep diving were deleted. There were 243 profiles, and this number was reduced by various methods to about 50, from which maximum likelihood procedures will select those most suitable for testing.

A goal of Phase I was to determine if multi-level diving is acceptable for recreational diving. Single day results could not be extrapolated to many days and multi-level profiles were a significant part of Phase IIb. Random selection led to the distribution of Table 6.

Table 6.

Days 1 & 4:	3 multilevel dives	1 single level dive
Days 2 & 5:	2 multilevel dives	2 single level dives
Days 3 & 6:	1 multilevel dive	3 single level dives

There was no design to the order of individual days, it just worked out that way, but it led to a surprising result. The data made it seem that, if anything, multi-level diving is desirable. Earlier graphs showed an irregular pattern of bubble grades throughout the week, and the pattern matched the distribution of multi-level profiles. If bubble grade data are combined and represented in a bar graph, the correlation between low bubble grades and multi-level profiles is arresting. While it is not conclusive that multi-level profiles are safer than square, the results suggest a more thorough study of the question (Figure 5).

Certain paired profiles create novel opportunities to compare square and multi-level dives. The goal was choosing a series of profiles consisting of four square dives that would be functionally equivalent to four multi-level dives. All corresponding pairs would have the same surfacing/descending pressure groups, the same total dive time, the same air use, and would all conform to U.S.N. criteria for air consumption. The opportunities are limited for profiles such as this, but the potential results are intriguing. Eleven pairs were selected to meet the listed criteria, and the maximum likelihood method determined that the greatest degree of statistically determined risk exists with the three pairs in Table 7.

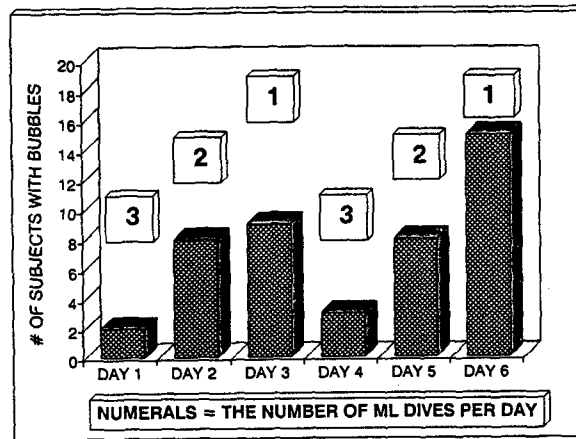

Fig. 5. Comparison of Phase Iib bubble events and number of multi-level dives/year.

Table 7.

7a	SQUARE			MULTI-LEVEL			SPG	SI	BGP
	DIVE	D/T	TT	D1/T1	D2/T2	TT			
# 1	60/54	55	130/09	50/45	56	V	50	J	
# 2	50/37	38	80/11	45/26	38	V	50	J	
# 3	45/45	46	70/16	35/29	46	V	45	K	
# 4	40/70	71	75/13	35/57	71	X			

7b	SQUARE			MULTI-LEVEL			SPG	SI	BGP
	DIVE	D/T	TT	D1/T1	D2/T2	TT			
# 1	45/65	66	120/13	35/51	66	S	64	F	
# 2	45/65	66	100/09	40/55	66	X	80	F	
# 3	45/65	66	100/09	40/55	66	X	60	I	
# 4	45/65	66	85/10	40/55	66	Z			

7c	SQUARE			MULTI-LEVEL			SPG	SI	BGP
	DIVE	D/T	TT	D1/T1	D2/T2	TT			
# 1	40/70	71	130/07	35/62	71	Q	50	G	
# 2	40/70	71	100/08	35/60	70	V	50	J	
# 3	40/70	71	90/09	35/62	71	X	60	I	
# 4	40/70	71	70/12	35/58	71	W			

TT: Total Time, surface-to-surface      D1/T1: Depth and Time, Level 1  
 D2/T2: Depth and Time, Level 2      SPG: Surfacing Pressure Group  
 SI: Surface Interval                      BPG: Beginning Pressure Group

Divers will rotate through these pairs on an alternating basis, with each diver performing both halves of two pairs without any repetition, providing control over any individual susceptibility to bubbling. Current plans propose that the water trials begin late this year.

### Summary

- Phase I consisted of 911 compressions, both dry chamber and open water.
- Phase Iib consisted of 475 dry chamber compressions.

- This equals 1,386 compressions with no cases of DCS, and with only limited bubbling.
- Each of these compressions exceeded the U.S.N. limits, some by a great amount.
- Phase IIa had 51 dry chamber compressions.
- One case of Type I DCS occurred. Bubble grades were higher than in the other phases.
- The total of all phases is 1,437 compressions, with one case of DCS.

Plans are being discussed to evaluate multi-day diving in a controlled water environment and which would not only evaluate rigorous square profiles but provide a comprehensive comparison to multi-level profiles as well. If this program is accomplished, the aggregate of all dives in the trials would total nearly 3,000.

Whether multi-day limitations would be eased on completion of successful field trials is difficult to assess at this time. For now, PADI limits its recommendations to the scope of Phase I tests, namely, three dives per day, and DSAT continues to print precautionary notices on the RDP. It is possible that these recommendations will remain in their present form. If problems occur in the water trials, restrictions on multi-day repetitive diving may be expanded. If future testing and continued field experiences are as successful as before, there may be grounds to consider easing the limitations. It will become appropriate to ask these questions only after more information has become available.

#### Related Literature

- Boycott, A.E., G.C.C. Damant, and J.S. Haldane. 1908. Prevention of compressed air illness. *J. Hyg.*, 8: 342-443.
- DesGranges, M. 1956. Standard air decompression table. U.S. Navy Experimental Diving Unit, Research Report #5-57.
- DesGranges. 1957. Repetitive diving decompression tables. U.S. Navy Experimental Diving Unit, Research Report #6-57.
- Eatock, B.C. 1984. The correspondence between intravascular bubbles and symptoms of decompression sickness. Decompression Group Symposium, Undersea Medical Society Annual Scientific Meeting.
- Lauckner, G.R., R.Y. Nishi and B.C. Eatock. 1984. Evaluation of the DCIEM 1983 decompression model for compressed air diving (series A-F). Defence and Civil Institute of Environmental Medicine, Research Report No. 84-R-72.
- Lauckner, G.R., R.Y. Nishi and B.C. Eatock. 1984. Evaluation of the DCIEM 1983 decompression model for compressed air diving (series G-K). Defence and Civil Institute of Environmental Medicine, Research Report No. 84-R-73.
- Lauckner, G.R., R.Y. Nishi and B.C. Eatock. 1985. Evaluation of the DCIEM 1983 decompression model for compressed air diving (series L-Q). Defence and Civil Institute of Environmental Medicine, Research Report No. 85-R-18.
- Miller, J.W. and I.G. Koblick. 1984. *Living and Working in the Sea*. Van Nostrand Reinhold, New York, Ch.1: 6-13.
- Nishi, R.Y., B.C. Eatock, I.P. Buckingham and B.A. Ridgewell. 1982. Assessment of decompression profiles by ultrasonic monitoring, Phase III: No decompression dives. Defence and Civil Institute of Environmental Medicine, Research Report No. 82-R-38.

- Powell, M.R. and M.P. Johansen. 1978. Ultrasound monitoring and decompression sickness. Sixth Symposium in Underwater Physiology.
- Powell, M.R., M.P. Spencer and O. Von Ramm. 1982. Ultrasonic surveillance of decompression. *The Physiology and Medicine of Diving*, 3rd Edition, Bennett, P.B. and D.H. Elliott, (Eds.). Ch 16: 404-434.
- Powell, M.R., M.P. Spencer, and R.E. Rogers. 1988. Doppler ultrasound monitoring of gas phase formation following decompression in repetitive dives. *Diving Science and Technology*, Inc. publication, Santa Ana, CA.
- Powell, M.R. and R.E. Rogers. 1988. Doppler Ultrasound Monitoring of gas phase formation in divers performing multi-level and repetitive dives. *Undersea Biomed. Res.* 15 (Suppl): 84.
- Powell, M.R. 1989. Diving: a chaotic system? Unpublished report.
- Powell, M.R. and R.E. Rogers. 1989. Doppler ultrasound monitoring of gas phase formation and resolution in repetitive diving. *Undersea Biomed. Res.* 16 (Suppl); 8.
- Powell, M.R. 1990. Doppler monitoring of repetitive and repetitive, multi-day diving in human subjects. 61st Annual Scientific Meeting, Aerospace Medical Association
- Rogers, R.E. and M.R. Powell. 1988. Development of multi-level and repetitive tables for recreational divers. *Undersea. Biomed. Res.* 15 (Suppl): 84.
- Rogers, R.E. and M.R. Powell. 1989. Controlled, hyperbaric chamber tests of multi-day, repetitive dives. *Undersea Biomed. Res.* 16 (Suppl): 8.
- Spencer, M.P. and D.C. Johansen. 1974. Investigation of new principles for human decompression schedules using the Doppler ultrasonic blood bubble detector. Technical report for Office of Naval Research.
- Spencer, M. P. 1976. Decompression limits for compressed air determined by ultrasonically detected blood bubbles. *J. App. Physiol.*, 40:2, 229-235.
- Thalmann, E.D., I.P. Buckingham and W.H. Spaur. 1980. Testing of decompression algorithms for use in the U.S. Navy underwater decompression computer. U.S. Navy Experimental Diving Unit, Research Report #11-80.
- Thalmann, E.D. and F.K. Butler. 1983. A procedure for doing multiple level dives on air using repetitive groups. U.S. Navy Experimental Diving Unit, Research Report #13-83.
- Thalmann, E.D. 1984. Phase II testing of decompression algorithms for use in the U. S. Navy underwater decompression computer. U.S. Navy Experimental Diving Unit, Research Report # 1-84.
- Thalmann, E.D. 1985. Development of a decompression algorithm for constant 0.7 ATA oxygen partial pressure in helium diving. U.S. Navy Experimental Diving Unit, Research Report #1-85.
- Thalmann, E.D. 1985. Repetitive/multi-level dive procedures and tables for constant 0.7 ATA oxygen partial pressure in nitrogen diving. U.S. Navy Experimental Diving Unit, Research Report #9-85.
- Thalmann, E.D. 1986. Air-N<sub>2</sub>O<sub>2</sub> decompression computer algorithm development. U.S. Navy Experimental Diving Unit, Research Report #8-85.

U.S. Navy Diving Manual, NAVSEA 0994-LP-001-9010, January 1979.

US Naval Flight Surgeon's Manual, ONR N00014-76-C-1010, 1978.

Vann, R.D. 1982. Exercise and decompression. Third Annual Scientific Meeting, Great Lakes Chapter, Undersea Medical Society.

Vann, R.D. 1982. MK XV UBA decompression trials at Duke, a summary report.

Vann, R.D. 1982. Doppler bubble measurements and decompression sickness. Undersea Biomed. Res. 9 (Suppl): 24.

Vann, R.D. 1985. DCS risk and no-stop air diving. Undersea Biomed. Res. 12 (Suppl): 30.

Weathersby, P.K., L.D. Homer and E.T. Flynn. 1984. On the likelihood of decompression sickness. J. Appl. Physiol. 57(3): 815-824.

Workman, R.D. 1957. Calculation of air saturation decompression tables. U.S. Navy Experimental Diving Unit, Research Report #11-57.

Workman, R.D. 1965. Calculation of decompression schedules for nitrogen-oxygen and helium oxygen dives. U.S. Navy Experimental Diving Unit, Research Report #6-65.

Appendix.

DSAT TESTS, PHASE IIB

#	LEVEL 1	LEVEL 2	LEVEL 3	LEVEL 4	SI
1.1	120 / 13	70 / 11	50 / 14	35 / 13	80
1.2	80 / 16	50 / 13	40 / 25		180
1.3	60 / 48	35 / 54			180
1.4	40 / 90				689
2.1	95 / 22	65 / 5	50 / 13	35 / 26	72
2.2	70 / 22	40 / 37			180
2.3	55 / 59				180
2.4	45 / 92				716
3.1	90 / 25	55 / 9	35 / 40		87
3.2	60 / 38				92
3.3	50 / 61				180
3.4	40 / 90				802
4.1	110 / 16	70 / 8	50 / 13	40 / 15	66
4.2	75 / 17	50 / 11	35 / 55		180
4.3	60 / 49	35 / 41			180
4.4	40 / 90				682
5.1	100 / 20	65 / 6	50 / 13	35 / 26	80
5.2	70 / 24	40 / 49			180
5.3	50 / 73				180
5.4	45 / 92				680
6.1	85 / 27	50 / 17	35 / 26		95
6.2	65 / 31				117
6.3	55 / 53				60
6.4	40 / 100				-

Appendix (cont'd.)

DSAT TESTS, PHASE I

#	LEVEL 1	LEVEL 2	LEVEL 3	LEVEL 4	SI
1.1	130/12				43
1.2	45/83				
2.1	55/85				57
2.2	55/37				
3.1	85/27				43
3.2	45/72				
4.1	45/100				76
4.2	85/20				
5	120/14	55/25			
6	100/20	50/29			
7	80/30	45/32			
8	80/55	40/25			
9.1	120/14				40
9.2	55/49				
10.1	75/35				57
10.2	55/47				
11.1	100/20				77
11.2	75/29				
12	130/12	70/13	45/29		
13.1	110/17				37
13.2	85/31				23
13.2	45/51				
14	130/12	80/21	45/23	35/42	
15.1	130/12				43
15.2	90/18				37
15.3	80/32				21
15.4	40/71				
16.1	90/25	45/34			49
16.2	80/26				
17.1	55/85				24
17.2	55/27	40/20			
18.1	130/12	50/41			84
18.2	80/21	45/33			
19.1	110/17	85/10			33
19.2	50/47	35/37			32
19.3	80/17	40/29			
20.1	120/14	80/19	45/22		23
20.2	40/87				
21.1	85/45				37
21.2	85/17	45/28	35/38		
22.1	95/22				39
22.2	55/35	40/34	35/17		
A1	100/18				33
A2	85/28				30
A3	50/38				
B1	80/21				30
B2	80/33				30
B3	55/28				
C1	85/36				28
C2	55/32				25
C3	50/33				



## DESIGN OF DECOMPRESSION TRIALS - DCIEM EXPERIENCE

*Ronald Y. Nishi*

Defence and Civil Institute of Environmental Medicine  
1133 Sheppard Ave. W.  
P.O. Box 2000  
North York, Ontario M3M 3B9 CANADA

*Although statistical significance is desirable in testing the safety of decompression models or tables, it is impossible to conduct enough dives to reach this goal. Decompression model/tables testing is governed more by practical considerations such as the number of dive subjects available, the time available for testing, the facilities available or required, and most importantly, the funding available. Within these constraints, one must design the model, generate the decompression tables from this model, select the profiles to be tested, and conduct the tests. The Defence and Civil Institute of Environmental Medicine has been involved in an active program of table testing and dive profile validation since 1979. Projects have included the evaluation of the Kidd-Stubbs dive computer model (1979), a study of no-decompression dive limits (1980), adapting a dive computer model for oxygen decompression (1982), development and testing of the DCIEM air tables (1983-1986), and development and testing of new mixed gas (84/16 HeO<sub>2</sub> tables) (1986-1991).*

### Introduction

The Defence and Civil Institute of Environmental Medicine (DCIEM) has been involved in an active program of decompression modelling, dive table generation, and dive profile/table testing and validation. Since the start of the diving research program in 1962, DCIEM has produced a successful dive computer model (1967), a new set of air decompression tables (1985), and a new set of mixed gas tables using 84%/16% HeO<sub>2</sub>. This has involved a number of major decompression studies requiring a large number of well-controlled chamber dives and thousands of man-dives including repetitive dives as well as single dives.

The testing of decompression tables or profiles requires considerable resources in terms of manpower, facilities, funding and time for planning and executing the dives. Traditionally, the absence of clinical symptoms of decompression sickness (DCS) has been taken to be the ultimate indicator of decompression safety. The acceptance or rejection of a given profile has depended on an "acceptable" incidence of DCS in some set number of dives, or on achieving a set number of dives without incurring DCS. There are no standard criteria for determining what these numbers should be. From a statistical point of view, using the binary outcome of DCS or no DCS would require many more dives than are normally feasible (Weathersby, 1990). Decompression testing is governed more by practical considerations such as the number of dive subjects available, the facilities available, the time available to conduct the dives, and most importantly, the funding available.

In recent years, the use of the Doppler ultrasonic bubble detector (Nishi, 1990) has proven valuable in providing an alternative or supplement to the traditional DCS vs. no DCS approach. With Doppler, it is possible to obtain far more information in terms of the decompression stress associated with a particular profile and it is not necessary to "bend" divers to determine whether or not that profile is safe.

In designing decompression trials, whether for testing existing decompression tables or developing new decompression models and tables, the aims of the tests and who the ultimate users of the tables must be kept in mind. The sometimes conflicting requirements of scientific testing, medical concerns, and operational requirements must be balanced. In addition, the degree of acceptable risk must be considered. For example, for military diving, a larger risk of DCS, say 5%, may be acceptable, whereas for recreational or scientific diving, this risk would not be tolerable; thus this would influence how the validation trials are carried out.

### Early Decompression Research at DCIEM

The impetus for decompression research at DCIEM was the development of a dive computer by Kidd and Stubbs (Kidd and Stubbs, 1969; Nishi, 1989a) to allow random depth dives, repetitive dives and dives with different gas mixtures. Such dives were difficult if not impossible to do with traditional diving tables with fixed depths and bottom times. A successful dive computer model was completed in 1967 with over 5000 man-dives tested. A minor modification was made in 1971 to improve the safety for deep dives. The profiles used for developing the dive computer consisted of standard square dives, random depth dives and a variety of repetitive dives. The computer was used extensively in the 1970's in hyperbaric chambers for experimental diving, training dives, equipment tests, and operational dives in the ocean. However, extensive use of the computer had shown that there were some limitations in the model.

The dive computers developed by Kidd and Stubbs were pneumatic mechanical analogue computers. In the 1970's, it became possible to design digital dive computers using microprocessors (Nishi, 1989a). Several versions incorporating the Kidd-Stubbs model were built. Thus, in 1979, a critical study of the Kidd-Stubbs model was undertaken to determine the operational limits of the model (Nishi *et al.*, 1981). A microprocessor-controlled dive computer was used to follow the model predictions for the safe ascent depth exactly as calculated. Three bottom times at 36 meters of seawater (msw), 45 msw and 54 msw were selected for testing. The first dive tested was 36 msw for 50 min, the middle profile for that depth. Unfortunately, this dive resulted in decompression sickness (DCS) in 3 of the 6 subjects in the dive (two Type 1 DCS, 1 Type 2 DCS). This necessitated a rethinking of the original aims of the tests and a "backing off" of the profiles being tested, in that the longest bottom time profiles at each depth were deleted and other profiles with shorter bottom times were introduced.

This particular case underscores an important consideration in decompression table testing. Should there be an abort criteria for terminating a dive series, or should one carry on and continue with testing? For example, if an abort criterion such as terminating the trials after one serious case of DCS or three non-serious cases of DCS had been in place, the trials would have been over after the first dive. It is important to review the situation and determine whether there were any extenuating circumstances or predisposing factors before making any decisions. In this case, the trials were continued by "backing off" from the original maximum limits. These trials were important because it was necessary to determine the operational limits of the Kidd-Stubbs model.

All dives were conducted with a dive computer, using continuous decompression by following the safe ascent depth exactly until 3 msw, and then holding at 3 msw until surfacing was possible. The Doppler ultrasonic bubble detector, using the Kisman-Masurel grading method for bubbles (Nishi, 1990), was used for evaluating the decompression stress of these dives. Monitoring was conducted at approximately 20 to 30 minute intervals for at least 2 hours after surfacing. Locations monitored were the precordial region and the right and left subclavian veins. Measurements were obtained at each location for both the "at rest" and "after movement" conditions. However, any cases of DCS were determined only by the diagnosis of classical symptoms of DCS and not by bubble scores.

In total, 172 man-dives were conducted with 7 cases of DCS. The results (Figure 1) showed that the Kidd-Stubbs model could be divided into three zones - mild (bubble grades 0 and 1 in the precordial region at rest), moderate (bubble grade 2) and severe decomposition stress (bubble grades 3 and 4). Only the fittest and well-acclimatized divers could dive at the severe stress limit. The results also showed that the model was overly conservative for short bottom times.

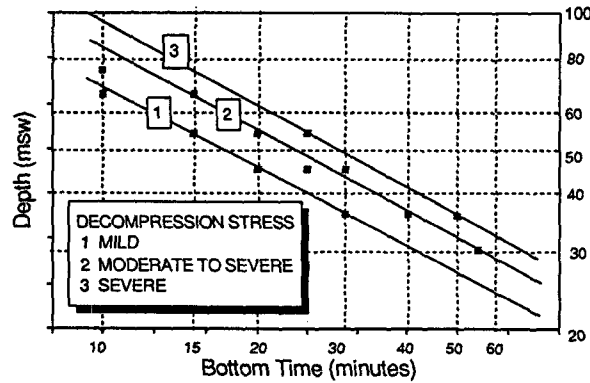

Figure 1. Evaluation of Kidd-Stubbs model showing profiles tested and decompression stress.

No-decompression limits as defined by the Kidd-Stubbs model were considerably shorter than other published limits. Thus, in 1980, a critical study of no-decompression limits was carried out (Nishi *et al.*, 1982). A review showed that there were considerable variations in existing no-decompression limits. A number of depths and bottom times were selected for testing and 185 man-dives were conducted with two cases of DCS. As in the study of the Kidd-Stubbs model, it was possible to define zones for mild, moderate and severe decompression stress (Figure 2) using the Doppler ultrasonic bubble detector. The results showed that existing limits for deep dives appeared to be more conservative than necessary and for shallow depths, the existing limits were not conservative enough. Similar findings were reported earlier by Spencer (1976).

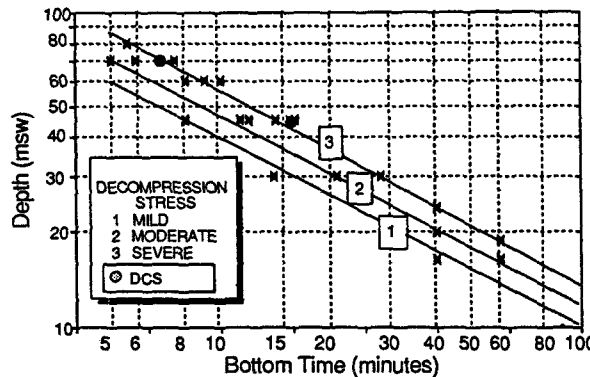

Figure 2. Evaluation of no-decompression limits showing profiles tested.

In 1982, it was decided to investigate whether the Kidd-Stubbs dive computer model could be adapted for oxygen decompression to extend the safe diving limit into the severe decompression stress

range (Nishi, 1984). Both in-water oxygen decompression and surface decompression with oxygen procedures were tested (64 man-dives, 3 cases of DCS) to show that oxygen decompression dives were feasible and could be done safely with a dive computer.

### Development of New Air Decompression Tables

In 1983, DCIEM set out to develop a new set of air decompression tables for the Canadian Forces with options for standard air decompression, in-water oxygen decompression, and surface decompression with oxygen (Nishi, 1987). Because of the vast amount of dive data that existed on diving with the Kidd-Stubbs model, it was decided to adapt this model by reducing decompression times in the regions where the model was known to be overly conservative and to extend the decompression times in moderate to severe and severe decompression stress zones. Considerable computer simulations were conducted by varying the model parameters and comparisons were made with other existing tables before a suitable model was determined.

Operational limits (Hobson, 1989) were defined for the new tables, comprising a normal dive limit (maximum of 54 msw/30 min) and exceptional exposure limit (maximum of 72 msw/40 min). Tables were generated using the three decompression options and selected profiles were chosen for testing. Repetitive diving rules were devised. With the exception of the no-decompression dives, all dives were decompressed using stops at 3 msw intervals by following the safe depth predicted by an on-line dive computer programmed with the new model. Any variations in depth were automatically taken into account and the decompression profile followed was the optimum profile for that dive. Decompression stops were terminated as soon as the computer indicated that it was possible to move to the next shallower stop. Thus, the decompression profile was always the "worst case" profile, *i.e.*, the mathematical model was always being tested and not a printed set of tables.

In testing repetitive dive profiles, the decompression for the second dive also followed the computer-predicted value and in most cases, the resulting decompression profile was shorter than that which would have been calculated from a printed set of tables using repetitive diving rules (Figure 3). In general, following a set of rules for repetitive diving would result in a more conservative decompression.

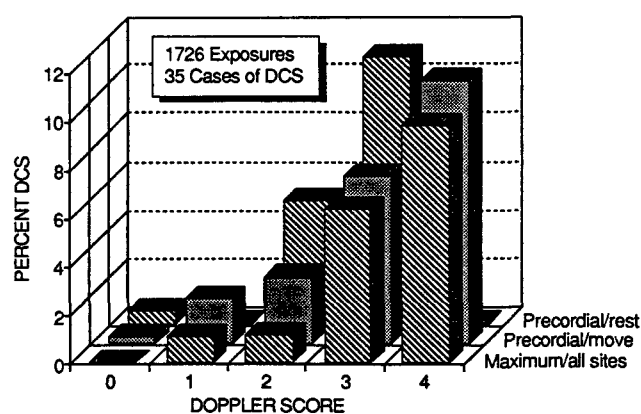

Figure 3. Correspondence between decompression sickness and Doppler bubble scores for air dives.

For testing surface decompression profiles, a 7 minute surface interval from the time of leaving the last in-water stop to reaching 12 msw in the recompression chamber was used. The surface interval of 7

minutes was selected to give greater flexibility and to avoid the problem of "omitted decompression" which could occur if shorter surface intervals were specified and delays occurred for some reason. The full 7 minutes was always used for the test dives to test the worst case situation. In actual operational dives, it would be expected that the surface interval be kept as short as possible, typically 4 to 5 minutes.

Dive subjects consisted of both wet-working divers in 5-10 °C water, swimming against a swim bar or on a bicycle ergometer and dry-resting subjects. Almost all of the subjects were monitored for bubbles after the dive with a Doppler ultrasonic bubble detector as described earlier. In determining a criterion for decompression stress, profiles in which the majority of subjects had "at rest" bubble grades of 0 or 1 in the precordial region were considered to be acceptable. Figure 4 shows the correspondence between DCS and Bubble Grades for air dives.

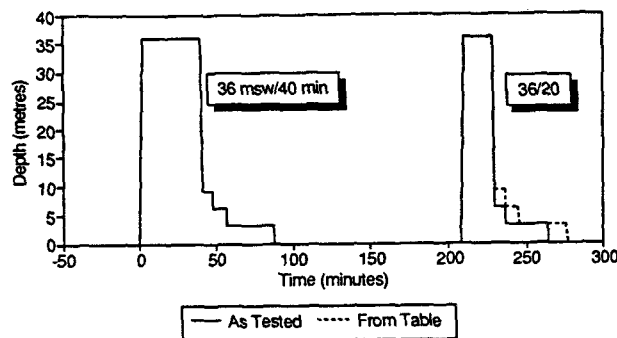

Figure 4. Example of repetitive dive conducted by dive computer compared to profile generated by repetitive diving rules.

Figure 5 shows the profiles actually dived (repetitive dive profiles are not shown). For standard air profiles, these were profiles in which the decompression times were shorter than in the original Kidd-Stubbs model, profiles in the moderate exposure range, profiles at the normal exposure limit, and profiles at the no-decompression limit. In-water oxygen decompression profiles were mainly at the normal air diving limit only, and surface decompression with oxygen dives were at the normal diving limit, in the exceptional exposure range, and at the exceptional exposure limit. Repetitive dives tested included standard air followed by standard air, in-water oxygen dives followed by in-water oxygen dives, surface decompression followed by surface decompression, and surface decompression followed by standard air dives. No-decompression repetitive dives were also conducted. In all, over a period of approximately three years, 701 single man-dives and 221 repetitive dive pairs for a total of 1143 man-dives were conducted, resulting in 26 cases of DCS. (For dives from the no-decompression limits to moderate exposure bottom time dives, the incidence of DCS was 0.5%; for dives near the normal diving limit to the exceptional exposure limit, the incidence was approximately 3%). Investigation of some of these cases of DCS showed that there may have been other causative factors which contributed to the DCS.

In selecting profiles for testing, several assumptions had to be made. Since all profiles were calculated from a continuous mathematical model, it was assumed that all dives with similar decompression profiles and times would have similar decompression stress. Thus in trying to achieve some statistical confidence in the results, the results of different dive profiles could be combined. In addition, the model was a modification of an existing well-tested model with a large database of safe and unsafe dives; hence, it was possible to test a few specific profiles rather than test every possible combination of depths and bottom times, an impossible task. For repetitive dives, only a few specific

profiles were tested since the original Kidd-Stubbs model had been developed with repetitive diving as one of its goals.

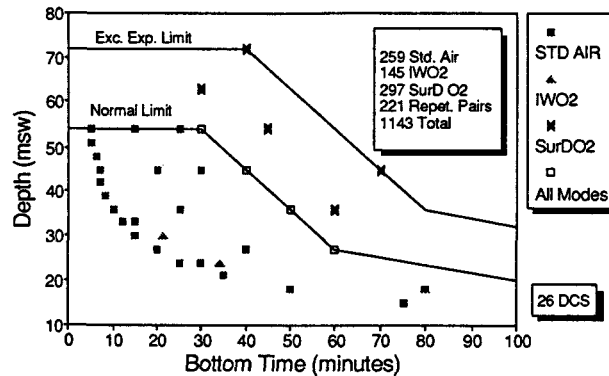

Figure 5. Profiles tested during the development of the DCIEM air decompression tables (repetitive dives not shown).

Table 1. Comparison of no-decompression repetitive dives tested with recommended dives calculated from DCIEM and U.S. Navy repetitive dive rules.

NO-DECOMPRESSION REPETITIVE DIVES				
First Dive (fsw/min)	SI (hr)	Second Dives		
		Tested	Recommended	US Navy
60/30	1.0	60/36	60/29	60/30
110/12	0.5	110/8.5	110/7	110/4
130/8	1.0	130/6.5	130/6	N.A.
120/10	1.0	60/38.4	60/30	60/36
60/50	1.5	60/33.4	60/26	60/24
50/75	1.0	90/11.9	90/9	N.A.

N.A. - not allowed

For no-decompression repetitive dives (Table 1), the second dive profiles tested were more liberal than those calculated from the repetitive dive rules devised for the DCIEM air tables (Nishi, 1986). The no-decompression limits calculated from the mathematical model are still extremely conservative. As a result, for single or first dives, the no-decompression limits were adjusted to be more in keeping with known safe no-decompression limits. However, for repetitive dives, it was decided to use the more conservative limits derived from the model and devise repetitive dive rules based on these limits for increased safety. Thus, the aim of the no-decompression repetitive dive trials was to determine if repetitive dives based on the no-decompression limits for single or first dives could be done safely.

Another consideration in conducting these tests was the problem of acclimatization from repeated diving. Although acclimatization may occur in compressed air workers who are exposed to many hours of pressure each day (Walder, 1987), the evidence is not clear for divers (Eckenhoff, 1987) who may be diving every day on air. Ideally, one would wish to have a fresh diver for every dive; however, as this would be impossible because of a limited pool of subjects and a limited time period for diving, compromises must be made. In these dives, a minimum of about 44 hours between the start of successive dives was observed for any given subject.

### Development of New Helium-Oxygen Tables

Following the successful development of the DCIEM/CF air diving tables in 1986, attention was devoted to developing a new set of mixed gas tables for the Canadian Forces to replace the US Navy Partial Pressure Tables for HeO<sub>2</sub> diving (Nishi, 1989b). It was decided to retain the mathematical model used for developing the air tables and to modify this model to take into account both helium and nitrogen absorption and elimination. The decompression profiles were designed for an 84% He, 16% O<sub>2</sub> mixture, using a switch to air at the first decompression stop, followed by the option of using in-water oxygen decompression at 9 msw, or surface decompression with oxygen, leaving the water after the 9 msw stop and completing the decompression at 12 msw in a recompression chamber. The aim of this development was to simplify the procedures for using HeO<sub>2</sub> and to make the procedures similar to and compatible with those for air diving. (This project subsequently became a joint program with the US Navy and Royal Navy).

A Normal Exposure Limit and Exceptional Exposure Limit were defined: The depth limit for Normal Exposures was chosen to be 90 msw based on the US Navy limit partial pressure of oxygen of 1.6 ATA. The total time in water at the Normal Limit was set to be approximately 3.5 h for the in-water oxygen decompression table. The depth limit for Exceptional Exposures was selected as 100 msw with the total time in water of approximately 4.5 h. Profiles selected for testing covered the entire range from short bottom times to the Exceptional Exposure Limit (Figure 6).

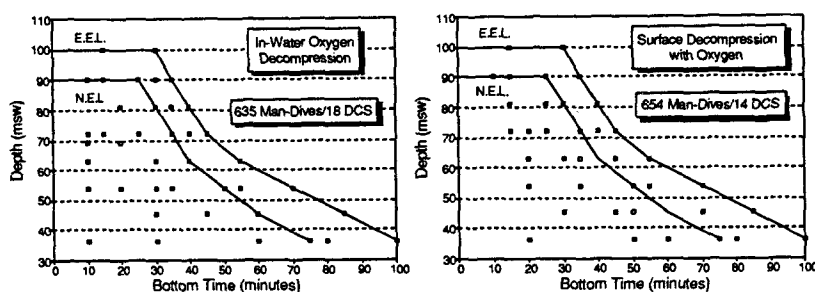
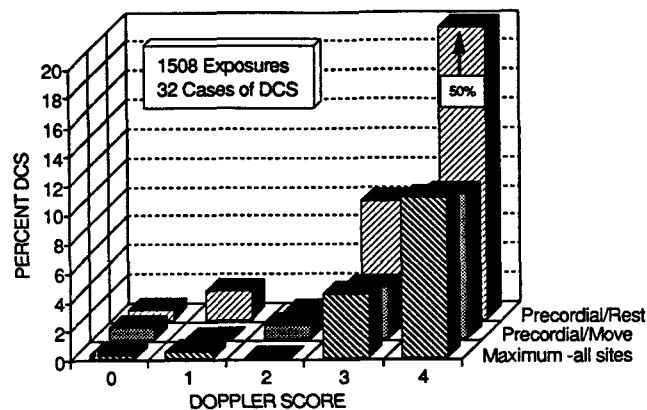

Figure 6. Decompression profiles tested for DCIEM helium-oxygen tables.

In selecting dive profiles, the decision had to be made as to which profiles to test first. The tendency is to start with the shallower depth and shorter bottom time profiles and work downward and outward toward the limits of the model. This procedure is generally favored by Human Ethics Committees and others who must approve such tests and, initially, was the approach taken. However, during discussions with the U.S. Navy, it was pointed out that testing should be done starting from the outer limits since if the model were to fail, it would most likely fail in this region. This would necessitate making some changes to the model to try to improve the safety, and could possibly alter profiles which had already been dived safely but which would then have to be retested. This turned out to be sound advice since it was found that surface decompression could not be carried out safely at the deeper depths. Thus several changes were made to the model to make it more conservative for deeper and longer dives. These included slowing down the initial ascent after the first decompression stop and increasing the in-water decompression time at 9 msw before commencing the surface interval.

Another important factor during this testing was to validate the model using in-water oxygen decompression first. It is difficult to validate the model using surface decompression because the surface interval represents a gross violation of the decompression model. Improving the safety of the surface decompression tables, if necessary, could be done by making procedural changes rather than further model changes. (The surface interval for test dives was maintained at 7 minutes as was done during the development of the air decompression tables).



**Figure 7. Correspondence between decompression sickness and Doppler bubble scores for helium dives.**

All diving was done following the predictions from a dive computer and not from the printed tables. Thus, the mathematical model was always being tested. Printed tables were always available for backup in case of computer failure.

Each dive consisted, in general, of at least 6 subjects, two wet-working divers wearing hot-water suits on bicycle ergometers in water of 10 °C and the rest dry subjects, either resting or lightly working. Subjects were divided into two or three teams depending on the number of subjects available. For helium dives, there appears to be more evidence for acclimatization after repeated diving. To avoid acclimatization effects, dive subjects had at least 72 hours between the start of successive dives. This was a compromise period since any longer period would have made the logistics of carrying out the planned dive program very difficult considering the number of subjects and the limited time period available (three weeks for each dive series) for conducting the dives.

Doppler ultrasonic monitoring for bubbles was conducted on all dive subjects. However, the criterion used for determining if a dive profile was stressful was different from that for air, with dives producing bubble scores greater than the Grade 2 level in the majority of subjects being considered too stressful. Figure 7, showing the relationship between DCS and Bubble Grades for helium dives, shows that the risk of DCS is greatest for Bubble Grades 3 and 4.

Over the 5-year period of the development, 1469 man-dives were tested, with 36 cases of DCS (all but two were Type 1 pain only DCS). Figure 6 shows the number of in-water oxygen and surface decompression man-dives conducted. The other 180 man-dives tested were emergency profiles. For the final tables developed, the incidence of DCS was approximately 2% for both the in-water oxygen decompression and the surface decompression with oxygen table. The HeO<sub>2</sub> development program has now been completed and the tables are being released for operational use. There are no plans at present for developing repetitive dive procedures for HeO<sub>2</sub> dives since there appears to be no demonstrated need for such procedures.

### Summary

The DCIEM approach to decompression table development and testing can be summarized by the following steps. First, the aims of the development/tests must be clearly defined. A model must be devised and profiles generated and compared with known safe and unsafe profiles (if available). Operational limits must be defined and profiles to be tested must be selected which would allow a fair



test of the model over the entire range of operation. The degree of risk acceptable during the operational use of the tables must be identified. Abort criteria, if specified, cannot be blindly followed, and each DCS incident must be reviewed. A contingency plan must be established to allow decompression testing to continue in the event of too many cases of DCS. Testing should only be terminated if it can be demonstrated that the model is definitely inadequate. Tests should, whenever possible, start at the outer limits of the model since any failure in the model would most likely occur at the limits. In designing the test schedules and dive teams, dive subjects must be selected to avoid possible acclimatization effects.

Second, if the tables are derived from a mathematical model of decompression, testing of profiles should be done with a real-time, on-line dive computer to test the underlying model and not from the printed tables derived from the model. Thus, the tests should be conducted for the "worst case" situation. Printed tables must be available for backup in case of computer failure. Accurate records of the depth-time profiles should be kept in sufficient detail for use by others in developing probabilistic models of decompression based on the method of maximum likelihood (Weathersby *et al.*, 1984).

Third, all dive subjects must be monitored with the Doppler ultrasonic bubble detector to determine the decompression stress of the dives. However, any diagnosis of decompression sickness should be from classical symptoms of DCS. Doppler results, however, can be used to assist in the diagnosis of DCS and to aid in the decision to accept or reject a dive profile in the absence of DCS. All subjects must be informed of the risks associated with experimental dives and be aware of the ground rules of behavior to minimize the effect of external factors on decompression safety.

#### Literature Cited

- Eckenhoff, R.G. 1987. Adaptation and latency. *In: Nashimoto, I. and E.H. Lanphier (Eds.) Proceedings of the Thirty-sixth UMHS Workshop, Decompression in Surface-Based Diving.* UHMS Publication, No. 73, Undersea and Hyperbaric Medical Society. Bethesda, MD. pp: 51-54.
- Hobson, B.A. 1989. Development and validation considerations in decompression table development. *In: Schreiner, H.R., and R.W. Hamilton (Eds.) The 37th Undersea and Hyperbaric Medical Society Workshop, Validation of Decompression Tables.* UHMS Publication 74, Undersea and Hyperbaric Medical Society. Bethesda, MD. pp: 25-29.
- Kidd, D.J. and R.A. Stubbs. 1969. The use of the pneumatic analog computer for divers. *In: Bennett, P.B. and D.H. Elliott (Eds.). The Physiology and Medicine of Diving and Compressed Air Work, 1st ed.* Bailliere, Tindall and Cassell. London. pp: 386-413.
- Nishi, R.Y., K.E. Kisman, B.C. Eatock, I.P. Buckingham and G. Masurel. 1981. Assessment of decompression profiles and divers by Doppler ultrasonic monitoring. *In: Bachrach, A.J. and M.M. Matzen (Eds.). Underwater Physiology VII: Proceedings of the Seventh Symposium on Underwater Physiology.* Undersea Medical Society. Bethesda, MD. pp: 717-727.
- Nishi, R.Y., B.C. Eatock, I.P. Buckingham, and B.A. Ridgewell. 1982. Safe decompression limits for no-decompression dives using the Doppler ultrasonic bubble detector. *Undersea Biomed. Res.* 9(S1): 27-28.
- Nishi, R.Y. 1984. Evaluation of compressed air dives with oxygen decompression using Doppler ultrasonic monitoring. *Undersea Biomed. Res.* 22(S1): 10.
- Nishi, R.Y. 1986. New Canadian Air Decompression Tables. *Canadian Diving Journal, Summer*, pp: 22-27.

- Nishi, R.Y. 1987. The DCIEM decompression tables and procedures for air diving. *In: Nashimoto, I. and E.H. Lanphier (Eds.) Proceedings of the Thirty-sixth UMHS Workshop, Decompression in Surface-Based Diving.* UHMS Publication, No. 73, Undersea and Hyperbaric Medical Society. Bethesda, MD. pp: 80-83.
- Nishi, R.Y. 1989a. Decompression computer experience in Canada. *In: Lang, M.A., and R.W. Hamilton, (Eds.) Proceedings of Dive Computer Workshop, American Academy of Underwater Sciences, Sept. 26-28, 1988.* University of Southern California Sea Grant Publication, USCSG-TR-01-89. pp. 69-79.
- Nishi, R.Y. 1989b. Development of new Helium-Oxygen decompression tables for depths to 100 msw. *Undersea Biomed. Res.* 16, Supplement: 26-27.
- Nishi, R.Y. 1990. Doppler evaluation of decompression tables. *In: Lin, Y.C., and K.K. Shida, (Eds.) Man in the Sea, Volume I.* San Pedro, CA: The Best Publishing Co. pp: 297-316.
- Spencer, M.P. 1976. Decompression limits for compressed air determined by ultrasonically detected blood bubbles. *J. Appl. Physiol.* 40: 229-235.
- Walder, D.N. 1987. Lessons from U.K. caisson/tunnel tables. *In: Nashimoto, I. and E.H. Lanphier (Eds.) Proceedings of the Thirty-sixth UMHS Workshop, Decompression in Surface-Based Diving.* UHMS Publication, No. 73, Undersea and Hyperbaric Medical Society. Bethesda, MD. pp: 7-10.
- Weathersby, P.K., L.D. Homer, and E.T. Flynn. 1984. On the likelihood of decompression sickness. *J. Appl. Physiol.* 57: 815-825.
- Weathersby, P.K. 1990. Confidence in Decompression Safety. *In: Lin, Y.C., and K.K. Shida (Eds.) Man in the Sea, Volume I.* San Pedro, CA: The Best Publishing Co. pp: 217-230.

### Decompression Trials Session Discussion

Ronald Y. Nishi, Moderator

- R. Vann: Shalini, did you have any particular target DCS incidence in establishing the USN dive trials?
- S. Survanshi: What I have proposed is a general tool for designing dive trials. If you have a target pDCS in mind, you will also have to select a couple of other criteria such as acceptable beta level and total number of DCS cases that you are willing to incur. Then you can come up with a dive trial design by simulation techniques.
- R. Vann: Is it correct that in the design of the sequential dive trial, the four schedules that are under test right now, the assumption was made that they were all iso-probability schedules?
- S. Survanshi: We are on shaky ground here, statistically speaking.
- R. Vann: That is not unreasonable, I do understand that.
- S. Survanshi: That is why the probabilistic approach will at least give us some basis for using different schedules.
- R. Vann: You have covered the testing of a single schedule. Now, if we assume the schedules are iso-probabilistic, we can lump them all together. If that assumption is correct, let us look at a couple of alternative methods. Assume we have enough time and money to do one thousand tests. What are the pros and cons under the assumption of testing 10 schedules 100 times each, 1,000 schedules one time each. This allows you to sample a greater range of profiles, particularly in repetitive diving where you have many different combinations?
- S. Survanshi: I would go for testing multiple schedules, but a low number of them so that you get overall safety of the entire range because we are not after just a single dive here.
- R. Vann: You are suggesting an intermediate approach?
- S. Survanshi: You may want to be a little less stringent on acceptance criteria of your pDCS level, but then you get answers on multiple different schedules rather than getting a good clear answer on one schedule and then what?
- R. Vann: Well, at least based on the single profile, you have come down around two hits in 28 trials.
- S. Survanshi: You could design something where you decide ahead of time what your willingness is to accept your pDCS level. What is the maximum number of cases of DCS you are willing to accept? Then you start designing your sequential design.
- R. Vann: Right, but the number of schedules to test is the key question is it not?
- S. Survanshi: That is where you could, if you have confidence in your original probabilistic model, then combine different schedules, but that gets a little shaky statistically.
- R. Vann: If you do not necessarily have confidence that the profiles you are testing are all iso-probabilistic, then you would want to test more of each given schedule? It is a statistical shell game, is it not?
- S. Survanshi: That is correct.
- R. Eckenhoff: Is the bubble volume calculated from the model?
- T. Fawcett: Yes.
- R. Eckenhoff: Is that normalized to anything? Is that per body?
- T. Fawcett: It is an absolute value. The reason that it does not correspond to the sigmoid dose response curve that I showed was because the sigmoid dose response curve is actually optimized to a previous model and I did not have the time to make another one.
- R. Eckenhoff: For a given person?
- T. Fawcett: It is optimized to a given data set, so it assumes the divers are the same.
- R. Eckenhoff: I have a question about the sequential model. You have accepted, *a priori*, that 2 out of 40 is your acceptance rate and you then have also accepted a confidence interval around that 2 out of 40. You stop early at 28 because you have not gotten any DCS based on your model, have you not reduced the power? What do you report to the world then? You really did zero of 28 and have you not reduced the power of that observation because you have got a new confidence level now instead of what you originally accepted for 2 out of 40?

- S. Survanshi: No, because we are not doing a strict fixed rule trial anymore. That is why you cannot just look at the binomial confidence anymore and just say it is zero out of 28 because you had already decided ahead of time what your schedule design was going to be. The power curve is where you will then know where your P(safe) is and where your P(unsafe) is and that is a statistically valid judgment afterwards.
- R. Eckenhoff: So, basically, because zero out of 28 and two out of 40 aren't different?
- S. Survanshi: Zero out of 28 could have come from lots of different pDCS values and I do not know exactly how to answer that question.
- R. Eckenhoff: I do not know how to ask it, either.
- T. Fawcett: Let me add one more thing to your question about the bubble dose. I would have been more correct to represent the probability, the risk of DCS, which is a function of bubble size. I thought that bubble size was intuitively obvious, but it is an internal number to the model and does not mean anything until you actually go back to the sigmoid dose response curve. For the model presented, the risk of DCS is on the order of less than one in 10,000.
- H. Vidars: The demographics seem to indicate that our current sport diving population is comprised of 20 to 30 percent female divers. Those numbers would not be as high for commercial and scientific divers, but there are increasing numbers of women in these endeavors as well. I am more than a little disconcerted that almost all of the information upon which the dive tables and the computers are based were all done on male divers. To what degree of certainty can you say that this compendium of information is indeed valid for female divers? Second, do the people who are doing the studies on tables and dive computers have plans in the future to include a substantial amount of females in their studies? Third, is it feasible to take the current data and to somehow add addenda to make it address itself to the female population?
- M. Lang: Can we maybe specify a response towards the repetitive diving aspect of this more general question?
- T. Fawcett: As far as the mathematical model I presented for repetitive surface interval oxygen, we did not exclude women from our study. The basic problem lies in the fact that with any mathematical modeling of decompression risk you have to use a database representing some known dives with known incidences of decompression sickness and unfortunately the only databases that are available for evaluation right now are primarily males. We do not know. We presume that the physiology is going to be comparable, but you are absolutely correct that our mathematical model, because of the data set that it represents, would constitute more male physiology. For future databases, you need a lot of hits to know where to draw the line.
- R. Eckenhoff: This is one area where there seems to be a dichotomy between altitude and diving data. Recent altitude data seems to confirm Bassett's work that women were more prone to altitude bends than men with a four times greater risk. The only two studies I am aware of in divers (one was Keith Zwingelberg's study) were unable to show a difference although the numbers were small. A study in our habitat in Florida looked at 30 women versus 30 men and the propensity to bubble and found no difference whatsoever. So, unless there is some physiological response to the bubbles that is different, which is not certainly impossible, then I would have to say that there is no difference.
- R. Vann: You are looking at two different factors and can ask the question in two ways. You can have a statistical significant difference and you can have a practically significant difference. The Air Force study had such very small incidences of decompression sickness that they may not be practically important. So, right now all the studies either indicate no difference or a very small difference between the sexes and I do not think there is any practical reason to be worried about it.
- H. Vidars: Then we can assume that all of this is equally valid for males and females?
- R. Vann: Well, I do not know we can assume that, but we do not have any evidence that indicates an important difference even from the Air Force study which showed the greatest difference.
- R. Rogers: As I understood your point, you suggested that women were not involved in these studies and in the DSAT Phase I study there were 30 percent women, and in the Phase II-B there were 40 percent women.

- K. Huggins: Was your comparison of dive time for the air versus nitrox versus nitrox with oxygen breathing at the surface based on tables or your model?
- T. Fawcett: That comparison was between standard Navy repetitive dive tables and the mathematical model. It would have been informative to plug the nitrox into the model as well. I do not think it would make too much difference because the first dives are very similar.
- J. Bozanic: You explained to us why you administered oxygen during the last 30 minutes of the surface interval prior to the dive. Then you went on to explain that was better because on the last dive the person had a lower decompression stress as evidenced by your bubble volume. Would the stress after the first dive be higher than the stress after the last dive if you had administered oxygen during the first 30 minutes instead of the last?
- T. Fawcett: Yes. The reason for choosing oxygen the last 30 minutes was convenience. I showed the last slide to demonstrate that by switching the oxygen from the beginning to the end, you can adjust the risk. I did not want to make any point about which one was better.
- J. Bozanic: Going on to look at the risk, it would appear that operationally, if one were to actually contemplate using oxygen for surface interval, it should be administered soon?
- T. Fawcett: The best thing would be to administer oxygen as soon as you surface after every dive.

**SESSION SUMMARIES**  
**AAUS Repetitive Diving Workshop**

Although diving is a relatively safe activity, all persons who dive must be aware that there is an inherent risk to this activity. Currently, the risk of decompression illness in the United States is estimated at 1-2 incidents per 1,000-2,000 dives for the commercial diving sector, 2 incidents per 10,000 dives for recreational diving activities and 1 incident in 100,000 dives for the scientific diving community.

**Recreational Diving**  
Peter B. Bennett, Moderator

1. Scientific diving programs provide continuous training, recertification and dive site supervision, which helps maintain established safe diving protocols. Recreational divers, who may lack such direct supervision, need to be aware of their need to stay within established protocols, especially when making repetitive dives over multiple days, in which the risk of DCS may be higher.
2. It is recommended that attention of divers be directed with emphasis on the ancillary factors to decompression risk such as fitness to dive, adequate rest, hydration, body weight, age and especially rate of ascent which should not be more than 60 feet per minute.
3. Divers are encouraged to learn and remember the signs and symptoms of decompression illness and report them promptly so as to receive effective treatment as rapidly as possible to prevent residual injury.
4. The use of oxygen breathing on the surface, whenever possible via a demand regulator mask system, to insure the highest percentage of oxygen to the patient, is recommended while awaiting treatment if decompression illness is thought to be present. The use of 100% oxygen in the water while awaiting treatment is not recommended for recreational diving.
5. There is a strong need for more controlled data on the relationship of decompression illness to multi-level, multi-day diving, especially with the provision of baseline data. Such a study could be made from information gathered from closed groups such as certain island areas and liveboard fleets where heavy recreational diving activities occur.
6. To help obtain information, dive computer manufacturers are encouraged to provide data loggers to computers so that a permanent record is available of dive depth, dive time, rate of ascent, etc. as close as every minute. This should be coupled with detailed accident reporting forms (e.g. DAN form) in the case of an accident.

**Scientific Diving**  
Glen H. Egstrom, Moderator

1. The position of recommending slower ascent rates seems to have gained support.
2. Increasing knowledge regarding the incidence of DCS indicates that our ability to predict the onset of DCS on multi-level, multi-day diving is even less sensitive than our ability to predict DCS on single square dives.
3. Although there is little evidence supporting either a pro or con position on multi-level, multi-day dives and a higher probability of DCS, there is sufficient evidence to encourage additional research on the problem.
4. There appears to be good evidence that there are many variables which can affect the probability of the occurrence of DCS symptoms. The ability to mitigate these variables through education, good supervision and training appears to be possible in such variables as hydration, fitness, rate of ascent, fatigue *et al.* and should continue to be promoted. Divers are subject to a host of specific conditions which may increase risk if precautions are not taken.

5. There appears to be support for the use of enriched air nitrox and surface oxygen breathing in scientific diving where higher gas loadings are anticipated in multi-level, multi-day dives. Adequate technical support is fundamental.
6. Since there seems to be little likelihood that we can avoid all decompression illness in multi-level, multi-day diving, we should focus educational objectives on:
  - a. the development of an appreciation for the realities of risk for DCS;
  - b. encouraging maximal prevention strategies; and
  - c. define, as clearly as possible, the conditions under which problems are known to occur.
7. There are techniques used in commercial diving applications which may be appropriate for some scientific diving applications which require unusual exposures.
8. The incidence of DCS in scientific diving appears to be about 1:100,000, in recreational diving at about 2:10,000 and in commercial diving at about 1:1,000-2,000. These levels are not unreasonable.

### Commercial Diving

Gary L. Beyerstein, Moderator

The following comments represent a consensus of the ADC members represented at this workshop.

1. Repetitive diving, multi-level and multi-day diving modes are considered normal, routine and essential practices in the commercial diving industry. They are performed safely and efficiently.
2. The use of surface decompression using oxygen is also essential to the safe and efficient conduct of commercial diving operations. Alternate methods to date have shown increased risk to the diver and have not reduced the incidence of DCS.
3. The quality of decompression (*i.e.* the effectiveness of the decompression table in controlling decompression stress) is much more important than the mode used when considering DCS risk.
4. A zero bends incidence rate is desirable but not thought to be achievable in all types of commercial diving. Given the commercial situation, with the ability to treat immediately and effectively, an incidence rate of 1 type I case of DCS per 1,000 to 2,000 dives is considered currently tolerable.
5. Current commercial practices and tables were developed from need and have been modified for safety. We feel they are currently tolerable. We look forward to a new generation of safer tables that will also increase our operational efficiency. Such tables will have longer bottom times at deeper depths without higher levels of risk. Such tables will need field validation. This will be greatly assisted by advanced dive profilers, field Doppler units, and an industry data base. We look forward to industry standard tables and therapy procedures.

### Dive Computers

John E. Lewis, Moderator

1. No data were presented that warrant revision of the recommendations of the 1988 AAUS Dive Computer Workshop.
2. Data presented indicate that limiting dives to the no-stop (No-D) range, plus training and experience adds up to a one hundred fold decrease in the incidence of DCS.
3. Multi-level diving is a commonly accepted practice, and it appears to be less stressful than square wave profile diving.
4. Repetitive NoD (no-stop) diving with dive computers within the tested envelope is a valid practice. Deep repetitive dives with short surface intervals should be given special consideration.
5. No data were presented that indicate multi-day diving requires any special rules.
6. To assist in the analysis of decompression illness, dive computer manufacturers should consider working with the Divers Alert Network to provide an indication of inert gas loading by profile recovery, group letter, or other simple technique.

### **Dive Recorders**

Karl E. Huggins, Moderator

1. Because of limited analysis of the existing profile database, no conclusions have been reached regarding repetitive diving limits.
2. Paper databases are too cumbersome, it is considered essential that future profile recorders have the ability to download dive profile information directly to personal computer (through standard I/O ports).
3. The following desirable dive recorder features were identified:
  - a. ascent/descent rate record;
  - b. long storage capacity (commercial diver suggested one month);
  - c. for data points collected in large time intervals (*i.e.* 2.5-3 minutes), the average depth during the interval as well as the maximum depth attained during the interval should be recorded;
  - d. depth resolution should be at least .3 msw (1 fsw);
  - e. "low" tech recorder (inexpensive, requiring daily dumps);
  - f. date/time stamps on each dive; and
  - g. diver/recorder identification.
4. Possible dive recorder enhancements:
  - a. two-way communication with personal computer (*i.e.* allows adjustment in sampling rate, initialization of program variables, setting of recorders' internal clock, etc.); and
  - b. data compression techniques (*i.e.* store rate of depth change instead of depth) for both the recorder and final computer storage.
5. A standardization of information and file formats would be advantageous, with PENNDEC or CANDID databases as possible starting points.
6. There is a need to obtain a list, from end users, of the minimal "header" information required. Suggested were:
  - a. DAN incident form information; and
  - b. time of incident to time of resolution.

### **Physiology, Medicine and Environment**

Richard D. Vann, Moderator

1. Investigate the arterialization of gas emboli (VGE) as a potential mechanism for spinal and cerebral DCS.
2. Investigate the ability of reduced ascent rate and short decompression stops to reduce the incidence of VGE.
3. Dose-response curves for direct decompression are of fundamental importance to the development of decompression procedures.
4. Classification of decompression illness should be by specific signs/symptoms to guide therapy and prognosis and provide improved data for analysis.
5. There is a potential risk of bone necrosis for long shallow dives followed by inadequate decompression.
6. Multiple decompressions per day for multiple days can be potentially hazardous. The number of dives per day and the number of consecutive days during which diving can be conducted with reasonable safety is uncertain at present and depends upon the decompression procedures that are used.

### **Data Analysis and Procedure Calculation**

R.W. Hamilton, Moderator

1. Maximum likelihood and other statistical techniques are useful for evaluation and assessment of new procedures based on past experience.



2. Predictive models are sensitive to the data set used to determine the parameter estimates of the model.
3. Field data can be useful and data exchange should be encouraged.

### **Decompression Trials**

Ronald Y. Nishi, Moderator

1. After all these years, we still do not know much about DCS. None of the table or dive computer developers really have decompression "models". What they actually have are decompression calculation methods as stated by Brian Hills in his book "Decompression Sickness".
2. There are two primary methods for developing decompression tables and designing decompression trials. The first is the traditional approach, where tables are developed from some model and selected profiles are dived to test whether or not DCS occurs. A variation on this approach is to include risk analysis. Dives are tested, either by following printed tables or by following dive computers. It is necessary to use other tools such as Doppler and complement analysis to determine decompression stress.
3. The second approach to designing trials is the probabilistic method. In this case, a large amount of carefully documented (well-calibrated) dive data is required to estimate the risk of DCS, compute optimum profiles and test with appropriate criteria for rejecting or accepting profiles. With the proper design of sequential tests, the total decompression time can be minimized and the number of trials and cases of DCS can also be minimized. The probabilistic method appears to be the way of the future but still needs further development. To make it work, accurate dive data and DCS information are required, which the military, scientific, commercial and recreational diving communities must supply.
4. What does this all mean for the scientific, recreational and commercial diving communities? Although designers and testers of decompression trials may talk about incidences or risks of DCS which are much higher than the different communities are willing to accept, the eventual tables will probably be more effective than those commonly in use now. It must be kept in mind that DCS is a probabilistic event.

**AMERICAN ACADEMY OF UNDERWATER SCIENCES**  
Repetitive Diving Workshop  
March 18-19, 1991  
Duke University Medical Center

Gary W. Albin, Ph.D.  
NMRI  
Bethesda, MD 20889-5055 U.S.A.  
(301) 295-5867, fax 295-0782

Peter B. Bennett, PhD  
F.G. Hall Laboratory  
Duke University Medical Center  
Box 3823  
Durham, NC 27710 U.S.A.  
(919) 684-5514, fax 684-8666

Gary L. Beyerstein  
SubSea International, Inc.  
1600 Canal Street  
PO Box 61780  
New Orleans, LA 70161  
(504) 523-3617, fax 596-6160

Stephen M. Blair  
Metro-Dade Env. Res. Mgmt.  
111 NW 1st Street Suite 1310  
Miami, FL 32128-1971  
(305) 375-3376, fax 375-3360

Lawrence Blumberg, MD  
12 Old Lyme Road  
Lutherville, MD 21093-3718  
fax (301) 366-1260

Jeffrey E. Bozanic  
Next Generation Services, Inc.  
PO Box 3448  
Huntington Beach, CA 92605-3448  
(714) 846-5220, fax 846-6299

Frank C. Chapman  
UNCW  
7205 Wrightsville Ave.  
Wilmington, NC 28403-3297  
(919) 256-3721, fax 256-8856

James M. Chimiak, MD  
N.E.D.U. Diving Medicine  
Panama City, FL 32407 U.S.A.  
(904) 234-4351 x 436, fax 234-4238

Ron Coley  
Tekna  
7992 Miramar Road  
San Diego, CA 92126 U.S.A.  
(619) 695-9130, fax 695-9402

David A. Dinsmore  
NOAA Undersea Research Program  
UNCW  
7205 Wrightsville Ave.  
Wilmington, NC 28403 U.S.A.  
(919) 256-5133, fax 256-8856

Joel Dovenbarger  
Divers Alert Network  
Box 3823  
Duke University Medical Center  
Durham, NC 27710 U.S.A.  
(919) 684-2948

David B. Duane, Ph.D.  
NOAA  
National Undersea Research Program  
1335 East West Highway  
Silver Spring, MD 20910  
(301) 427-2427, fax 427-2799

Roderic G. Eckenhoff, MD  
Institute for Environmental Medicine  
University of Pennsylvania  
1 John Morgan Building  
Philadelphia, PA 19104-6068  
(215) 898-9100

Glen H. Egstrom, Ph.D.  
UCLA  
3440 Centinela  
Los Angeles, CA 90066-1813 U.S.A.  
(213) 825-2060, 391-8933 (h)

Michael N. Emmerman  
Suite 900  
522 Fifth Ave.  
New York, NY 10036-7673  
(212) 790-9591, fax 302-4932

Thomas A. Fawcett, MD  
Box 3823  
Duke University Medical Center  
Durham, NC 27710 U.S.A.  
(919) 684-2948

Caroline E. Fife, MD  
UTHSC  
6431 Fannin 5.020 MSMB  
Houston, TX 77030  
(713) 797-4268, fax 794-4157

Andre Galerne  
International Underwater Contractors  
222 Fordham Place  
City Island, NY 10464  
(212) 885-0600, fax 885-2389

Michael L. Gernhardt  
Ocean Systems Engineering, Inc.  
1441 Park Ten Blvd.  
Houston, TX 77084  
(713) 492-2800, fax 492-8958

Wayne A. Gerth, PhD  
Box 3823  
Duke University Medical Center  
Durham, NC 27710

Brett C. Gilliam  
Ocean Tech  
3098 Mere Point Road  
Brunswick, ME 04011  
(207) 442-0998, fax 442-9042

Yoshiyuki Gotoh, MD  
Saitama Medical School  
38 Morohongo, Moroyama, Iruma-Gun,  
Saitama 350-04 JAPAN  
0492-95-1111 x2103

Hugh D. Greer, MD  
Santa Barbara Medical Clinic  
PO Box 1200  
Santa Barbara, CA 93102  
(805) 964-6211

Max H. Hahn, Ph.D.  
Abt. f. Immunobiologie  
Med. Einr. d. Uni. Duesseldorf  
Moorenstrasse 5  
D-4000 Duesseldorf 1 WEST GERMANY  
49-211-311-2533, fax 49-211-34-2229

R.W. (Bill) Hamilton, Ph.D.  
Hamilton Research, Ltd.  
80 Grove Street  
Tarrytown, NY 10591 U.S.A.  
(914) 631-9194, fax 631-6134

Donald E. Harper, Ph.D.  
Texas A&M Marine Lab  
4702 Ave. Q  
Galveston, TX 77551 U.S.A.  
(409) 740-4540, fax 744-4103

John Hazelbaker  
Commercial Diving Service, Inc.  
PO Box 360568  
Columbus, OH 43236  
(614) 258-2000, fax 258-2047

Paul A. Heinmiller  
ORCA Industries  
10 Airport Way  
Toughkenamon, PA 19374 U.S.A.  
(215) 268-3164, fax 268-2267

John Henderson, Ph.D.  
Room S111 Sherman Hall  
South Campus  
State University of New York  
Buffalo, NY 14214 U.S.A.  
(716) 831-2275, fax 831-2344

Karl E. Huggins  
Dept. of Atm. & Oceanic Sciences  
1220 Space Research Bldg.  
University of Michigan  
Ann Arbor, MI 48109 U.S.A.  
(313) 936-0522 (w), 995-4674 (h)

Alan W. Hulbert, Ph.D.  
NOAA Undersea Research Program  
UNCW  
7205 Wrightsville Ave.  
Wilmington, NC 28403 U.S.A.  
(919) 256-5133, fax 256-8856

Jean-Pierre Imbert  
COMEX Services  
36 Bd des Oceans  
13275 Marseille Cedex 9, FRANCE  
33-91-235047, fax 33-91-401280

Walter C. Jaap  
FDNR  
Marine Research Lab  
100 8th Ave SE  
St. Petersburg, FL 33701-5095 U.S.A.  
(813) 896-8626, fax 823-0166

Steven Jewett  
Institute of Marine Science  
University of Alaska  
Fairbanks, AK 99709  
(907) 474-7841, fax 474-7204

Doug Kesling  
NOAA Undersea Research Program  
UNCW  
7205 Wrightsville Ave.  
Wilmington, NC 28403 U.S.A.  
(919) 256-5133, fax 256-8856

Michael A. Lang  
Smithsonian Institution  
OAS/Research-Scientific Diving Officer  
A & I Bldg. Suite 2201  
Washington DC 20560 U.S.A.  
(202) 786-2815, fax 786-2819

William M. Langley  
NCSC-NEDU  
Panama City, FL 32407 U.S.A.  
(904) 234-4351, fax 234-4238

Charles E. Lehner, Ph.D.  
2115 Observatory Drive  
Dept. of Preventive Medicine  
University of Wisconsin  
Madison, WI 53706  
(608) 262-4900, fax 262-7871

John E. Lewis Ph.D.  
4524 Palos Verdes Drive E.  
Rancho Palos Verdes, CA 90274 U.S.A.  
(714) 896-2368, fax 896-1313 x2368

G. Yancey Mebane, M.D.  
Divers Alert Network  
Box 3823  
Duke University Medical Center  
Durham, NC 27710 U.S.A.  
(919) 684-2948

Robert Merriman  
Global Divers & Contractors, Inc.  
PO Box 10840  
New Iberia, LA 70562  
(318) 234-3483

H.G. (Bud) Mills  
American Oilfield Divers, Inc.  
PO Box 507  
6219 Highway 90 East  
Broussard, LA 70518 U.S.A.  
(318) 234-4590, fax 367-8843

Richard E. Moon, MD  
Dept. of Anesthesiology - Box 3094  
Duke University Medical Center  
Durham, NC 27710

David Nagle  
Diving Officer  
University of California  
Santa Cruz, CA 95064 U.S.A.  
(408) 459-4286, fax 429-4882

Jack Nichols  
University of Miami-RSMAS  
4600 Rickenbacker Cswy.  
Miami, FL 33149  
(305) 361-4107

Ari Nikkola  
SUUNTO  
Juvan teollisuuskatu 8  
SF-02920 Espoo, FINLAND  
358-0-847033, fax 358-0-843810

Ronald Y. Nishi  
D.C.I.E.M.  
1133 Sheppard Avenue West  
Box 2000  
North York, Ontario M3M3B9 CANADA  
(416) 635-2140, fax 635-2104

Bill Oliver  
SeaQuest, Inc.  
2151 Las Palmas Drive  
Carlsbad, CA 92009 U.S.A.  
(619) 438-1101, fax 438-3142

Dan Orr  
Divers Alert Network  
Box 3823  
Duke University Medical Center  
Durham, NC 27710 U.S.A.  
(919) 684-2948

Terry Overland  
Oceaneering International, Inc.  
PO Drawer H  
Morgan City, LA 70381 U.S.A.  
(504) 395-5247, fax 395-5443

Russell E. Peterson, Ph.D.  
Peterson Technical Service  
1104 St. Anne's  
West Chester, PA 19382 U.S.A.  
(215) 793-1895, fax 793-1896

Claude A. Piantadosi, MD  
F.G. Hall Hyperbaric Laboratory  
Box 3315  
Duke University Medical Center  
Durham, NC 27710

Michael Powell, PhD  
SD-5  
NASA/JSC  
Houston, TX 77058  
fax (713) 483-6227

John Reed  
Harbor Branch Oceanographic Institution  
5600 Old Dixie Hwy.  
Ft. Pierce, FL 34946  
(407) 465-2400, fax 465-2446

Jack Reedy  
CalDive International  
PO Box 1016  
Morgan City, LA 70381 U.S.A.  
(504) 631-0315, fax 631-9708

Drew Richardson  
P.A.D.I.  
1251 E. Dyer Road Suite 100  
Santa Ana, CA 92705-5605 U.S.A.  
(714) 540-7234 x269, fax 540-2609

Terrence Rioux  
Diving Officer  
Iselin 151  
Woods Hole Oceanographic Institution  
Woods Hole, MA 02543 U.S.A.  
(617) 548-1400 x2239, fax 540-8675

Raymond E. Rogers  
Diving Science and Technology Corp.  
4020 Alvar Drive  
Pensacola, FL 32504 U.S.A.  
(904) 432-2494, fax 433-0548

Ray Scharf  
Diving Safety Office  
East Carolina University  
Minges Coliseum  
Greenville, NC 27858  
(919) 757-4632

Steve Sellers  
Diving Safety Office  
East Carolina University  
Minges Coliseum  
Greenville, NC 27858  
(919) 757-4632

Phillip Sharkey  
Diving Officer  
URI/GSO  
Narragansett, RI 02882 U.S.A.  
(401) 792-6900

Karl W. Shreeves  
PADI  
1251 E. Dyer Road #100  
Santa Ana, CA 92705-5605 U.S.A.  
(714) 540-7234 x305, fax 540-2609

David G. Southerland  
Box 3823  
Duke University Medical Center  
Durham, NC 27710 U.S.A.  
(919) 684-2948

Gregg R. Stanton  
Academic Diving Program  
Florida State University  
Room 10 Montgomery Bldg.  
Tallahassee, FL 32306 U.S.A.  
(904) 644-3450, fax 644-8297

James R. Stewart  
Scripps Institution of Oceanography  
Diving Program A-010  
La Jolla, CA 92093 U.S.A.  
(619) 534-4445, fax 534-5306

Shalini Survanshi  
N.M.R.I.  
Mail Stop 38  
Bethesda, MD 20889-5055 U.S.A.  
(202) 295-5898

Woody Sutherland  
Duke Marine Lab  
Beaufort, NC 28516 U.S.A.  
(919) 728-2111

Peter Tikuisis, Ph.D.  
DCIEM  
1133 Sheppard Ave. West  
PO Box 2000  
North York, Ontario M3M 3B9 CANADA  
(416) 635-2099, fax 635-2104

Richard D. Vann, Ph.D.  
F.G. Hall Laboratory  
Duke University Medical Center  
Box 3823  
Durham, NC 27710 U.S.A.  
(919) 684-3305, fax 684-6002

Hilary Vidars  
159 Buckingham Road  
Tenafly, NJ 07670  
(201) 569-1605

Chris Wachholz  
Divers Alert Network  
Box 3823  
Duke University Medical Center  
Durham, NC 27710 U.S.A.  
(919) 684-2948

Mark Walsh  
DACOR Corporation  
161 Northfield Road  
Northfield, IL 60093 U.S.A.  
(708) 446-9555 fax 446-7547

AMERICAN ACADEMY OF UNDERWATER SCIENCES  
**REPETITIVE DIVING  
WORKSHOP**



**PROGRAM**

Sponsored by

AAUS  
DAN  
DEMA  
NOAA

F.G. Hall Hyperbaric Laboratory  
ADC

**March 18 - 19, 1991**

Searle Conference Center  
Duke University Medical Center  
Durham, NC

Workshop Co-Chairs:

**Michael A. Lang, Smithsonian Institution**

**Richard D. Vann, Duke University**

**SUNDAY, MARCH 17, 1991**

20:00-21:30: Repetitive Diving Workshop Reception  
Brownstone MedCenter Inn

**MONDAY, MARCH 18, 1991**

07:15: Registration and Continental Breakfast  
Searle Center, Duke University Medical Center

07:45: *Welcoming Address.*

Michael A. Lang, Smithsonian Institution  
Richard D. Vann, Duke University

**I. Recreational Diving**

08:00: *Introduction.*

Peter B. Bennett, DAN

08:05: *1991 Recreational Diving Survey.*  
Drew Richardson, PADI

08:25: *European Experience.*

Max H. Hahn, University of Dusseldorf

08:45: *Ocean Quest Experience.*

Brett Gilliam, Ocean Tech

08:55: *Panel Discussion.*

Peter B. Bennett, Moderator  
D. Richardson, M. Hahn, B. Gilliam, J. Bozanic

**II. Andrea Doria Dives**

09:25: *Andrea Doria Dives.*

Larry Blumberg, MIEMSS

09:35: Break

**III. Scientific Diving**

09:50: *Introduction.*

Glen H. Egstrom, UCLA

09:55: *Scientific Diving Program Overview.*  
Woody Sutherland, Duke Oceanographic

10:15: *Institute of Nautical Archaeology.*  
Caroline Fife, University of Texas

10:30: *Panel Discussion.*

Glen H. Egstrom, Moderator  
M. Lang, W. Sutherland, C. Fife, D. Kesling, D. Harper, J. Stewart

11:00: Break



**IV. Commercial Diving**

11:15: *Introduction.*

Andre Galerne, IUC

11:20: *Europe and North Sea Operations.*

Jean Pierre Imbert, COMEX

*ADC Member Presentations*

11:40: Subsea International - Gary Beyerstein

11:50: Global Divers and Contractors - Bob Merriman

12:00: Cal Dive - Jack Reedy

12:10: American Oilfield Divers - Bob Suggs

12:20: Oceaneering International - Terry Overland

12:30: Commercial Diving Services - John Hazelbaker

12:40: *Panel Discussion.*

Andre Galerne, Moderator

J.P. Imbert, G. Beyerstein, B. Merriman, J. Reedy, B. Suggs, T. Overland, J. Hazelbaker

13:10: Lunch

**V. Dive Computers**

14:25: *Overview.*

John E. Lewis, Oceanic

14:45: *European Activity.*

Max H. Hahn

*Manufacturer Presentations*

15:05: Orca Industries - Paul Heinmiller

15:15: Suunto - Bill Oliver/Ari Nikkola

15:25: Dacor - Mark Walsh

15:35: Tekna - Ron Coley

15:45: *Panel Discussion.*

John E. Lewis, Moderator.

M. Hahn, P. Heinmiller, B. Oliver, A. Nikkola, M. Walsh, R. Coley.

16:15: Break.

**VI. Dive Recorders**

16:40: *Introduction.*

Karl Huggins, University of Michigan

16:45: *Review and Norwegian Profile Recorder*

Russ Peterson

17:05: *Japanese Profile Recorder and Experience.*

Yoshiyuki Gotoh, Saitama Medical School

17:20: *SUNY Profile Recorder.*

John Henderson

17:30: *Suunto Units Overview.*  
Bill Oliver

17:40: *Delphi Overview.*  
Paul Heinmiller

17:55: *DAN Accident Reports.*  
Joel Dovenbarger

18:00: *Panel Discussion.*  
Karl Huggins, Moderator.  
R. Peterson, Y. Gotoh, J. Henderson, B. Oliver, A. Nikkola, P. Heinmiller, J. Dovenbarger

18:30: Announcement.

19:30-22:00: Reception and Banquet  
PAPAGAYO RESTAURANT

**TUESDAY, MARCH 19, 1991**

07:30: Continental Breakfast

**VII. Physiology, Medicine and Environment**

08:00: *Decompression Physiology.*  
Richard D. Vann, Duke University

08:30: Discussion

08:45: *Dive Profiles and Adaptation.*  
Charles E. Lehner, University of Wisconsin

09:15: Discussion

09:30: *Decompression Thresholds.*  
Roderic G. Eckenhoff, University of Pennsylvania

09:50: Discussion

10:00: *Quantifying Decompression Sickness.*  
Richard E. Moon, Duke University

10:15: Discussion

10:25: Break

**VIII. Data Analysis and Procedure Calculation**

10:40: *Primary and Secondary Data.*  
R.W. Hamilton, Hamilton Research Ltd.

10:55: Discussion.

11:05: *Ocean Systems Engineering/Penn*  
Michael Gernhardt

11:30: Discussion

11:40: *Duke University.*  
Wayne Gerth

12:00: Discussion

12:10: *DCIEM.*  
Peter Tikuisis

12:30: Discussion

12:40: *U.S. Navy.*  
Gary Albin

13:00: Discussion.

13:10: Lunch.

**IX. Decompression Trials**

14:30: *Design of Trials.*  
Shalini Survanshi, U.S. Navy

14:50: Discussion.

15:00: *Surface Interval Oxygen.*  
Tom Fawcett, Duke University.

15:20: Discussion.

15:30: *DSAT Dive Trials.*  
Raymond E. Rogers, PADI

15:50: Discussion.

16:00: *DCIEM Trials.*  
Ronald Y. Nishi, DCIEM.

16:20: Discussion.

16:30: *Conclusion and Recommendations.*  
Michael A. Lang, Smithsonian Institution  
Richard D. Vann, Duke University

17:15: Closing of Workshop.