

THE EFFECTIVENESS OF DIVE COMPUTERS IN REPETITIVE DIVING

Edited by

R.W. Hamilton



1995

Undersea and Hyperbaric Medical Society, Inc.
10531 Metropolitan Avenue
Kensington, MD 20895
U.S.A.

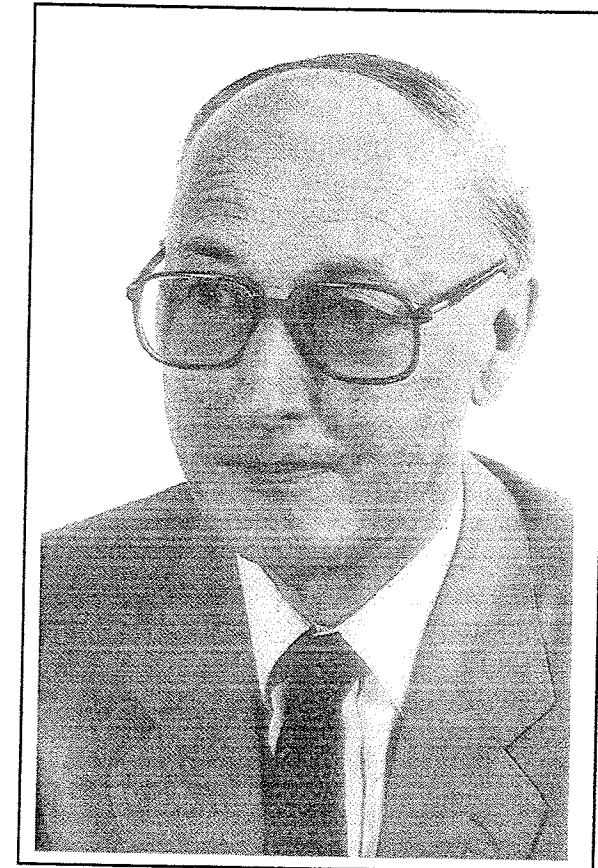

This workshop is dedicated to the memory of

Albert A. Bühlmann

1923 - 1994

PREFACE

This Workshop grew out of a continuing effort by UHMS to provide information to recreational divers and to involve them in its annual meetings. The idea has been to get the scientists, researchers, and authors to interact with recreational divers on topics of special interest to that community. One significant sequence of programs, the "Myths of Diving" panel which was originated by Bill Lawrence and has long been a feature of the Great Lakes Chapter meeting, has grown into an effective ongoing recreational divers' program at the annual UHMS meetings.

Clearly dive computers are a big part of contemporary recreational diving, and a big issue in the use of dive computers is their function in repetitive diving. A program dedicated to recreational divers on that topic seemed like a good idea for the Halifax meeting. This idea was conceived by the Program Committee after the program for the annual meeting was more or less in place, and the best we could do was to "shoehorn" the Workshop into the meeting timetable. But despite its being scheduled over the lunch hour and in competition with a poster session, the Workshop was well attended—enough so that Dr. Caroline Fife was herself borrowing chairs from an adjacent room as more attendees crowded into the room.

Although this attests to the timeliness of the topic, production of this report has been anything but timely. Our excuses are feeble, the main one being a matter of internal approval of some of the material in a structure that did not give getting out workshop reports a high priority. Because of the detailed contributions of the participants, we feel the product was worth waiting for.

Our thanks to the 1993 Program Committee for setting this rolling (particularly Caroline Fife and Richard Moon), to the participants, and to Lee Greenbaum and Jane Dunne and colleagues for their support at the home office. In addition to grateful appreciation of those participants who came at their own expense, we thank their sponsors for assisting some of them with travel expenses, since this Workshop had no budget for travel. We acknowledge the tedious work by Eileen Whitney in doing the typing and formatting which bridged a major software upgrade and relearning period, and especially for her struggles with not-very-compatible graphics formats (this 71 page report includes 62 graphics).

Perhaps my happiest moment in this process (prior to that of dropping the camera-ready copy in the express mail box) came on the morning of the Workshop, when at a breakfast meeting I spotted Prof. Bühlmann slip into the back of the room. To that point I did not know for sure that he would make it, and it was with great relief that I noted his unpretentious arrival. Not only for his participation in this Workshop, a trivial speck among his awesome contributions to the field of decompression science, but for all his work and for being a good friend, we dedicate this workshop report to him.

R.W. Bill Hamilton
Tarrytown, NY
1995 May 18

List of participants

Dr. Albert A. Bühlmann (deceased 1994)
Laubholzstrasse 78
CH 8703 Erlenbach
SWITZERLAND

Dr. Guy de Lisle Dear
F.G. Hall Environmental Laboratory and
Divers Alert Network (DAN)
Duke University Medical Center
Box 3823
Durham, NC 27710

Dr. Carl Edmonds
Diving Medical Centre
66 Pacific Highway
St. Leonards 2065
AUSTRALIA

Mr. Bret C. Gilliam
Ocean Tech
HC33, 7 Stone Tree Road
Arrowsic Island
Bath, ME 04530-9401

Dr. Max Hahn
Humboldtstrasse 10
D-4044 Kaarst 1
GERMANY

Dr. R.W. Hamilton
Hamilton Research, Ltd.
80 Grove Street
Tarrytown, NY 10591

Mr. John Hardy
Argo Diving Services
PO Box 1201
Avalon, CA 90704

Dr. Russell E. Peterson
Peterson Technical Service
1104 St. Anne's
West Chester, PA 19382

CAPT Edward D. Thalmann, MC, USN
Diving Medicine Department
Naval Medical Research Institute
Bethesda, MD 20814-5055
[Currently: Department of Occupational
Medicine
Duke University Medical Center
Durham, NC 27710]

Dr. Richard D. Vann
F.G. Hall Environmental Laboratory
Duke University Medical Center
Box 3823
Durham, NC 27710

Table of contents

Dedication	i
Preface	iii
List of participants	v
Table of contents	vii
Introduction	1
Misuse of model based decompression computers: The need for validation.	C Edmonds. 3
Behavior of dive computer algorithms in repetitive dives: Experience and needed modifications.	AA Bühlmann. 11
Workman-Bühlmann algorithm for dive computers: A critical analysis.	MH Hahn. 19
Manifestation of decompression illness in divers using dive computers.	GdL Dear, PJ Denoble, RD Vann. 27
Review of current dive computers with critique and recommendations.	J Hardy. 33
Practical use of dive computers in sport diving.	BC Gilliam. 41
Validation with data supplementing or in lieu of chamber testing.	RE Peterson. 49
The NMRI probabilistic decompression model: Performance on repetitive and multi-day dives.	ED Thalmann, EC Parker, SS Survanshi, PK Weathersby, and PC Kelleher. 55

INTRODUCTION

R.W. Bill Hamilton, Chairman

Hamilton Research, Ltd., Tarrytown, NY 19591-4138

The background for this workshop is based on the fact that there are now quite a number of dive computers, and they have been around for about 10 years or so now. They seem to be working. These devices were formerly called "decompression meters," but the term that has been agreed upon and is now used is "dive computers," sometimes abbreviated "DCs."

They seem to be working, but there also seem to be some problems. When the presence and use of dive computers by recreational divers became too obvious to ignore, the American Academy of Underwater Sciences could see that they were going to find their way into the scientific diving world. AAUS held a workshop in 1988, at Catalina Island, to look at dive computers and find out whether they should be endorsed for use by scientific diving programs, and, if so, under what conditions (Lang and Hamilton, 1989). What should the restrictions be, if any, and what are the techniques for using dive computers safely and effectively? That Workshop laid out some guidelines, and the present one builds on that basis.

One of the areas where uncertainty was indicated was multiple deep repetitive dives. Basically the AAUS Workshop just sort of "punted" at that point. That is to say, the assembled experts really did not come up with a definitive solution on how to do multiple deep repetitive dives; they only warned that this was a problem area and recommended it not be done.

There subsequently has been another workshop sponsored by the AAUS on repetitive diving (Lang and Vann, 1992). That is a comprehensive document that basically says—again—that we really do not have very much data on repetitive diving. We basically do not really know how to do it.

There are several algorithms for repetitive diving, but there is some uncertainty as to whether they work or not. This issue has been taken to court, and some dive computer companies are being sued, and some have lost. I will let Carl Edmonds tell you more about that.

The point is, doing repetitive dives with a dive computer is a sticky area. It is an area of great uncertainty. It is an area of great importance economically, and there is some potential for people to be hurt.

So, a lot is needed. This short, somewhat informal workshop brought together a diversified group of knowledgeable people with different perspectives to address this problem.

One of the major antagonists of the quality of dive computers is Carl Edmonds from Australia. He talks here about some of the problems with their use and their promotion, particularly their lack of validation. Then we have a discussion of how some of these problems may be dealt with in a dive computer that adapts to the diver and the dive, by (the late) Professor Albert Bühlmann from Zürich; more dive computers use Professor Bühlmann's algorithm probably than all others combined. Max Hahn, a physicist who works with the German Sports Diver Federation and who has been giving Prof. Bühlmann a rather hard time, gives his perspective of these problems, and suggests adaptations for dive computer algorithms.

We next have an approach to what the "box score" actually is, in results from DAN comparing DC divers with those that rely on tables, by Dr. Guy Dear and colleagues at Duke who also work with DAN. Then Jon Hardy, who operates a recreational and professional dive shop, is a consultant to dive computer companies, and

who has tested and written about dive computers, gives us an overview of what is out there in terms of capabilities, what they do and how they work, and his recommendations for future DCs.

We next hear from an experienced diver, Bret Gilliam, at the time of the Workshop a board member of the National Association of Underwater Instructors (NAUI) but now its chairman, with some practical thoughts about how to use dive computers.

Russ Peterson, who lives in Pennsylvania and has worked for years at NUTEC in Norway offers some possibilities on how to deal with the validation question, how to ensure that the "product" or output of a dive computer is validated. Then Ed Thalmann, with colleagues from the Naval Medical Research Institute, describes the basis of the new USN air decompression tables, and discusses their approach to repetitive diving and how it might affect the development of dive computers. Because this approach is statistical it is a bit different from the normal tactic that has been used in DCs so far.

One thing more should be mentioned. A workshop on dive computers in general was held with the meeting of the European Underwater and Baromedical Society (EUBS) at Basel in 1992. The proceedings of this workshop were not available at the time ours

was held, but are set for release in mid-1995 (Wendling and Schmutz, 1995).

References

Lang MA, Hamilton RW, eds. 1989 Jan. Proceedings of the American Academy of Underwater Sciences Dive Computer Workshop. USCSG-TR-01-89. Costa Mesa, CA: American Academy of Underwater Sciences. (For AAUS publications contact Don Harper, Publications Chairman of AAUS, 5007 Avenue U, Galveston, TX 77551, (409)740-4540; fax (409)740-5002; price for this workshop is \$15 plus shipping; he will invoice you or you may send a check with order, but shipping charges may not be known until the order is sent).

Lang MA, Vann RD, eds. 1992. Proceedings of Repetitive Diving Workshop. AAUSDSP-RDW-02-92. Costa Mesa, CA: American Academy of Underwater Sciences. [Available from Don Harper also; see previous reference].

Wendling J, Schmutz J, eds. 1995. Safety limits of dive computers: Decompression computers in scuba diving. Basel, Switzerland: Foundation for Hyperbaric Medicine. (Proceedings of a workshop held 92Sep18 at Basel during the Joint Meeting 3rd Swiss Symposium on Hyperbaric Medicine and XVIIIth Annual Meeting of the European Underwater and Biomedical Society. Copies available from publisher: Foundation for Hyperbaric Medicine, Kleinhüningwerstrasse 177, CH 4057, Basel, Switzerland. ISBN 3-0-8229-06-5.)

MISUSE OF MODEL BASED DECOMPRESSION COMPUTERS: THE NEED FOR VALIDATION

Carl Edmonds

Diving Medical Centre, NSW, Australia.

Edmonds C. 1995. Misuse of algorithms in dive computers: The need for validation. In: Hamilton RW, ed. *The effectiveness of dive computers in repetitive diving*. UHMS Workshop 81(DC)6-1-94. Kensington, MD: Undersea and Hyperbaric Medical Soc.

Dive computer (DC) manufacturers have diverted resources from validity testing into advertising. From 1986 many DCs have used algorithms that allow for excessive diving without adequate decompression. We investigated these because of decompression sickness that occurred. Many DC manuals are inaccurate and untruthful, and are used as advertising brochures instead of factual documents to educate the divers in the use, misuse, and maintenance of the equipment. Despite the ease of performing computer simulated dives to test the ranges of diving permitted, this procedure has been omitted by some manufacturers. It has been left to others, without such resources, to demonstrate the dangers of the equipment. A series of dive profiles from some present-day DCs demonstrate the radical nature of some of the square-wave, repetitive, and multilevel dives permitted. Since the 1988 AAUS report on DCs, many of the devices have become smaller, but not safer. The future safety of divers could be enhanced by ensuring:

- (1) Testing of DCs—not just their algorithms—to confirm a reliability at least equal to the US Navy tables.
- (2) Testing of the DC specifically toward the extremes of recommended depths, dive durations, surface intervals, dive numbers, etc.
- (3) Only after a DC is demonstrated to be relatively safe for square-wave and repetitive dives should there be an attempt to extrapolate to multilevel dives.
- (4) A series of written recommendations, identifying the safe use of the DC, should be ultimately incorporated into the computer function, i.e., one should not rely on the understanding, memory, and reliability of the diver.
- (5) The DC should be demonstrated to be valid physiologically and mechanically, and be electronically reliable. The promotion of a DC to the diving community should be subjected to the same validation procedures as a new diving table.

Introduction: The Australian experience

The main purpose of this current presentation is to summarize the mistakes of the 1980's and hopefully to help avoid them in the 1990's.

The only interest that my part-time employer, the Royal Australian Navy, has in decompression computers (DCs), is when they produce so many cases of decompression

sickness (DCS) in civilians that they require treatment which ties up Navy facilities.

In 1972 the RAN School of Underwater Medicine tested the SOS decompression meter, for this reason. A study (Quick, 1974) of that meter showed that it needed shorter decompression times than required by US Navy tables, when diving in excess of 60 feet, and for most repetitive dives. Similar observations were recorded independently by Howard (1976), in the USA, soon after this.

Attempts were also made to assess the safety of the Decobrain (LeSur, 1985) and Farallon (West and Edmonds, 1976) for similar reasons; however the units themselves were so unreliable that it was not warranted to continue the testing.

Again, for the same reason, in 1986 the first of the new generation dive computers—the Orca Edge—was subjected to similar trials to determine whether it was, as it claimed to be, safer than the US Navy tables (Edmonds and Anderson, 1987). These cases of DCS developed mainly after square wave (fixed depth) repetitive dives, usually on wrecks.

Square wave dives, i.e., dives at fixed depths, are frequently employed in recreational diving (diving on deep reefs, wreck diving, most open ocean diving, and sink holes) and also during professional diving (shell diving, especially pearl and sometimes abalone, underwater construction and maintenance, oil rig, and during searches, such as with police diving).

After performing some 73 separate chamber dive exposures with 3 DCs, at the RAN SUM, it was determined that the Orca Edge, appeared to be at least as conservative (safe) as the US Navy tables for single fixed level dives to a maximum depth of 120 feet.

This DC was recommended only for this type of diving and not for deeper diving, repetitive, or multilevel, unless specific restrictions were applied. Of the 50 repetitive dives performed, all of them were less conservative than the US Navy tables (and far less than the RNPL/BSAC tables) and the DCs permitted the omission of substantial decompression requirements.

Even when dive depths, durations and surface intervals were carefully selected in order to favor the DC, it still failed to reach the safety level of the US Navy tables—the DC allowing decompression dives (according to the US Navy tables) to be performed without decompression stops. The USN tables are not exactly God's gift to recreational divers, but they are recognized and serve as a standard.

Since this testing, and some subsequent work done on similar DCs (different brands but with similar algorithms), showed similar results, distributors of other DCs have not been prepared to submit their meters for further testing.

Nevertheless, occasional models have been made available and work on these, both by us and others (Lippmann, 1991) would suggest that such models as the Skinny Dipper, Delphi, Suunto SME-ML, and Suunto Solution have similar limitations.

There were many implications and hypotheses drawn from the results of the Australian experiments, which could have been easily derived and tested by the dive computer manufacturers before their equipment was marketed.

This work was re-presented at the AAUS DC workshop (Lang and Hamilton, 1989). Most of the audience focused on the **deep repetitive dives** that we performed, hourly, to depths between 100 foot and 140 foot, and our observation that these dives could have been done continuously all day without ever requiring decompression stops—according to the DC. This observation has subsequently been confirmed. The DC may be able to perform these dives, but most normal humans would not. This certainly highlighted one of the problems with the algorithms.

What was not appreciated, but which could have been deduced by inspecting the various dives performed, was that the longer the **surface interval**, the safer. If one considers purely square wave dives in the conventional recreational diving ranges, it looked as if a surface interval somewhere between 2 and 4 hours was required before the computer would approximate the US Navy Table.

It would be very easy to test this hypothesis, and to define more accurately the relationship between different depths and the surface interval, to bring the tables and the DC together. The 2-4 hour proposal is merely my guess-timate, based on the dives permitted by this particular computer algorithm. For other DC algorithms, it could be quite different.

As you are aware there is some interest in **litigation** at the moment, when the computers have permitted dives which would be totally unacceptable according to the US Navy Tables, without decompression. One typical example recently, which has now been concluded and therefore presumably no longer *sub judice*, was in a shell diver who performed 4 dives on one day, 3 on the next, and developed neurological DCS with very significant permanent damage. As expected these were square wave dives, moderately deep, but less than 100 fsw, and with short (1-2 hr) surface intervals. The type of computer being worn had a similar algorithm to the ones we had previously investigated and to DCs still available today, and the results were predictable.

Please do not assume because I have pointed out one way in which the DCs can be made a little safer—i.e., requiring a surface interval in excess of 2-4 hours—that this is the only problem with DCs. In our original Australian paper we pointed out that the algorithm used by the computers permitted **repetitive dives to increasing depths**. Despite longer surface intervals, they still permitted these obviously dangerous dives—according to most decompression theories—with omitted decompression. Many of the manufacturers have now included advice in their manuals advising against this practice, but there is no reason why this requirement could not be built into the computer and not left to the small print in the manual, which is either not read or is forgotten many months down the track.

The computer algorithm also permitted **multi-level diving** with a progressive increase in depth during the dive, a profile which would concern most diving physiologists. The algorithm did not distinguish greatly between some multilevel dives which increase in depth from others which decrease in depth—even though the latter are quite obviously more conservative. I note now that most of the manufacturers have included a recommendation in their manuals suggesting that there should be a progressive ascent on deep multilevel diving. It is important to appreciate that the statements I have made refer to one model-based computer, but there are

almost certainly limitations to other DCs, if they are designed to be attractive to the recreational diver. Thus it is up to each manufacturer to determine the limitations of their own equipment.

Industry responses

The lesson that I have learnt is that many of the manufacturers with whom I have dealt have not been particularly truthful in their advertising and in their manuals. They have very successfully employed a number of unprofessional techniques.

Testimonials

When we pulled the rug out from under the Orca DCs in 1987 with our reports, pressure was brought to bear to change our views. This was initially in the form of telephone calls from prominent personalities in the diving industry, and I classify these as “testimonial calls” or “manufacturers mouthpieces.”

Similar methods were used to promote various dive computers in the popular dive magazines (Murphy, 1985; Undercurrent, 1986), utilizing prominent personalities as role models, as opposed to supplying factual data on the DCs.

By the time the 1988 Workshop (Lang and Hamilton, 1989) on DCs was held, there were a few other workers who expressed doubts similar to ours i.e., that the computers available at the time seemed to be much less safe than the US Navy diving tables in many situations. The DCIEM group from Canada had always maintained a very professional and objective approach toward the dive computer development, as had the US Navy—quite unlike their private enterprise colleagues.

Despite the discussions at the AAUS meeting, the safety of the algorithms was not really addressed. New packaging covered similar algorithms, but with qualifications and safety recommendations buried in the manuals, to reduce the damage and alert the diver. Orca produced a booklet which it sold for \$1, separate from the DC, describing some of the AAUS recommendations.

Misuse of statistics

Some of the early manuals claimed no or few cases of DCS, but referred to the years when the DC was first introduced and not much used. In subsequent years the accident statistics had to be addressed because of the increased numbers of DCS cases using DCs.

During the 1988 Workshop the manufacturer of the most popular DC at the time quoted very favorable statistics demonstrating extensive diving activity while using his DC. Then he actually admitted that these statistics were purely theoretical and based on a number of hypotheses, assumptions and projected calculations based on their sales questionnaire—not on actual diving data at all.

The next descent down the statistics ladder was used by a dive boat operator, and very widely reported. It claimed 44,277 dives, with only 1 case of DCS—in a diver who allegedly misused his computer (Gilliam, 1991). In this Dive Boat Series there is no factual documentation on how the computers were used and therefore presumably many, if not almost all, of the diving would have been well within or below the computer limits.

Using the same naive form of logic, one could review the Royal Australian Navy diving exposures. In excess of 150,000 air dives were performed during my 9 year posting as the Officer in Charge of the Royal Australian Navy School of Underwater Medicine and there was not one case of DCS amongst the compressed air divers using the RAN tables. That is even better than the Dive Boat group. Unfortunately, the majority of our divers would not have approached the no-decompression limits of the tables. In fact, most of them dived quite shallow, less than 30 foot, inspecting the hulls of ships. It was not our tables that were that good, it was our diving practices.

Because in neither my series (which I quote with ridicule) and Gilliam's series (in which he was apparently serious) there is no indication of the number of divers that reached the no-decompression limits, as stipulated by the tables or the DCs. Thus both figures are meaningless,

and it would be improper to draw conclusions from them. It would be analogous to claim that the motor vehicle is safe to drive at 100 miles an hour when you have only tested it to 20.

Dr. Bruce Bassett (Lang and Hamilton, 1989) also claimed safety in his divers who used DCs, but at least Dr. Bassett pointed out that his DCs were not being used as stipulated by their algorithm or the manual, and that multiple safety factors were added.

If one is properly to assess the DCS incidence of any decompression procedure, whether it be tables or computers, it is imperative that the dives be performed at the limits permissible with such a table or computer. For recreational divers this means the no-decompression limit for repetitive diving.

Theoretical arguments

So many of the DC manuals quote established and reputable persons and tables, to imply support of their own device—without necessarily following the findings propounded by these experts or employed in their tables. An example is the continued reference to the US Navy table. In fact, the basis of many of the DCs is the Haldanian concept, modified, on which the US Navy tables were based. However, the manufacturer draws considerable promotional value from inferring that the DC is an application of the US Navy tables, modified to include more conservative bottom times and applied to multilevel diving.

Nothing could be further from the truth. The US Navy tables certainly were developed from the Haldane concepts but are not the direct application of them. Indeed they include modifications and safety factors built in. [*The USN tables are indeed a direct application of the Haldane concept, but this says nothing about the ascent constraints which were used and which are a necessary part of the definition of any "Haldane" algorithm—Ed.*]

I am not aware of any established decompression table that reflects solely a decompression theory or mathematical model. To my knowledge all practical decompression tables have

been modified by experience and logic. This has been well described by Hamilton (Hamilton, 1992) who stated in 1990, "researchers still have not been able to pinpoint either the mechanism of DCS or the true physiology and biophysics of decompression . . . for the present and the near future, the decompression table developer must rely on experience."

Ignoring the "rounding up" safety factors in the tables

Using the principles on which the US Navy tables are based, one could determine that it would be "safe" to spend 10 + x minutes at 130 fsw. The DC based on this theory, therefore, would also allow you to spend 10 + x minutes at 130 fsw. The US Navy table would not. It would only allow 10 minutes or jump to the next level.

In calculating the US Navy tables from their basic principles, the figures are always "rounded up" conservatively, so that if, for example, the calculations may permit 52 minutes at a certain depth; this is then rounded up to 60. The DCs do not do this. Thus they are not in a position to state that they are "following the US Navy tables"; they are not. The table would have been tested at that depth for 60 minutes—not 52.

The same rounding up effect applies to depths as it does to duration. The table is then rounded up. The DC is not.

However, many of the meters are not only less conservative, according to the US Navy tables, when the depths and durations are rounded up—they are also less conservative when rounded down! Thus often, if one compares some DCs to the US Navy table, rounding the DC depths and durations down to less than the actual dives, DCs may still omit decompression requirements on repetitive dives.

Misleading presentation of data

This is often not presented truthfully. Many of the tables in the DC manuals show the no-decompression limits, and compare these to the tables. The "bottom times" in the tables refer to the descent time plus the time spent at depth. The times given for the DC usually

refer only to the time to be spent at depth, i.e., no consideration is given to the descent time. This is not particularly significant in the shallow dives, but in the deeper dives (in excess of 120 feet) the few minutes extra taken to descend can be very significant, and the no-decompression times given for the DCs need to have this extra time, or a modification of it, added to their alleged "bottom time." Otherwise, the DC is made to appear safer than it really is.

Thus for tables, a "10 minute no-decompression dive," may require 2 minutes of descent time, during which there is less nitrogen uptake than in the remaining 8 minutes on the bottom. For the DC, "10 minutes" does not include the descent time, and therefore the correct "bottom time" for a dive to that depth is in excess of 10 minutes.

This is why many of the DCs quote "allowable no-decompression limits" but then exceed them when the meter is tested in the chamber, during deeper diving.

Fudge factors and making the DC safer

The fact that computer manufacturers have now (post 1988) had to include so many "safety factors" for the DC use and non-liability clauses in their manuals is a good indication of the problems the computers have caused. Any safety factors should be incorporated into the algorithm if they are required for safe diving, and not hidden in the manual to be resurrected during litigation proceedings.

The moment that you add safety factors into your experimental dive protocol, be it for tables or computers, you are no longer testing those tables or computers. What you are really testing is the values of the safety factors applied to those tables or DCs. If they are to be used, then they should be incorporated into the tables or computers.

Proposals for discussion

Multilevel and decompression diving

The discussions regarding the value of the DCs for multilevel diving is, in my opinion, totally

irrelevant. If the foundations of any structure are not stable then the edifices built on these foundations are also unlikely to be stable. Unless the DCs can first be demonstrated to be safe for square wave diving i.e., to a fixed depth, or demonstrated to be more conservative than the US Navy tables, then extrapolation to multilevel diving is premature.

The same can be said for decompression diving. If a DC is not safe for no-decompression diving then it does not warrant applying these devices to decompression diving.

Often valid research is quoted as support for multilevel diving or the DC, or claimed to be the basis on which the DC is based. Powell's interesting experiments (Powell et al, 1988; Hamilton et al, 1994) on bubble detection in divers at rest or performing mild exercise (1.2 litres oxygen per minute) for 40-50% of the dive, in a dry compression chamber, is often quoted as support in diving situations where the exercise load is often much greater. Both of these situations (water exposure and greater exercise) are far more likely to produce DCS.

Validation of decompression procedures (Schreiner and Hamilton, 1989)

Testing the limits of the DCs should be performed to **validate** them and to ensure safety.

This should be required for all newly introduced tables and model-based DCs (other than those which only allow for diving within the table limits). The limits include not only depths and durations but also surface intervals.

With DCs which are used on models, or computer algorithms, it would be very easy for the manufacturer to determine what the limits are of their square wave "non-decompression diving envelope," and compare these to the established tables.

This seems not to have been done in many cases, and it has been left to other workers—such as ourselves—who do not have access to the basic computer model, and who have to perform the real time dives in chambers, using the

DCs. This is a very time consuming occupation and we cannot adequately cover the full diving range. Also, it is evident that, once the first few reports were released from our facility, DCs were no longer made available for testing by us. The manufacturers not only have the DCs available to test, they have their own mathematical model already on computer. What took us months to work out could be achieved by the DC manufacturers within the day. Why are such computer models not made available to the scientific diving community for assessment?

Expert review and criticism

A Workshop specifically designed to advise on the validation of new decompression procedures was held in 1987 (Schreiner and Hamilton, 1989). This Workshop comprised the international experts in this field and the conclusions were very explicit, documenting what is required to validate new tables, or decompression procedures outside the range of the established tables.

When reviewing the procedures they recommend, it is evident to me that most of the commercial DC manufacturers have jumped from a mathematical model, directly to the use of the equipment in the field, without any adequate intervening experimental trials or operational evaluations. It also seems as if they have tended to miss out the continuing requirement of accurate dive data collection, analytical review, and interpolative improvements. Most improvements that had been incorporated have been those forced upon them by the adverse findings of others (Edmonds and Anderson, 1987; Lippmann, 1991; Lang and Hamilton, 1989).

Let me add one more thought about what the future may hold. That is the possibility of dysbaric osteonecroses (bone necrosis) in people who have been inadequately decompressed. We'll see about this in a few years.

References

Edmonds C, Anderson T. 1987. Assessment of the Orca Edge Dive Computer. SPUMS J 17(3):119-127.

Gilliam BC. 1991. Computers vs. table usage. Sources 3(1):39-41.

Hamilton RW. 1992. The basics of preparing decompression procedures. In: Pilmanis AA, ed. Proceedings 1990 Hypobaric Decompression Sickness Workshop. AL-SR-1992-0005. Brooks Air Force Base, TX: Air Force Systems Command.

Hamilton RW, Rogers RE, Powell MR, Vann RD. 1994. Development and validation of no-stop decompression procedures for recreational diving: The DSAT Recreational Dive Planner. Santa Ana, CA: Diving Science and Technology.

Howard RS, Bradner H, Schmitt K. 1976 Sep. Theory and evaluation of the single pneumatic resistor decompression computer. Med & Biom Engineering 14:570-579.

Lang MA, Hamilton RW, eds. 1989 Jan. Proceedings of the Dive Computer Workshop. USCSG-TR-01-89. Costa Mesa, CA: American Academy of Underwater Sciences.

LeSur G. 1985. Personal communication on investigations carried out at the Royal Australian Navy School of Underwater Medicine.

Lippmann J. 1991. Reviewing the safety of dive computers. SPUMS Journal 21(4):204-207.

Murphy G. 1985. Orca Edge update. Skin Diver 34:11.

Powell MR, Spencer MP, Rogers RE. 1988 May. Doppler ultrasound monitoring of gas phase formation following decompression in repetitive dives. Santa Ana, CA: Diving Science and Technology Corp.

Quick D. 1974. Evaluation of the automatic decompression meter. RANSUM Report 2/74. HMS Penguin, Balmoral, NSW: Royal Australian Navy School of Underwater Medicine.

Schreiner HR, Hamilton RW, eds. 1989. Validation of decompression tables. UHMS 74(VAL)1-1-88. Bethesda, MD: Undersea and Hyperbaric Med Soc., pp 163-167.

Undercurrent. 1986. A review of two decompression computers. Part 1, Oct; Part 2 Nov/Dec.

West D, Edmonds C. 1976. Evaluation of the Farallon Decompression Meter. RANSUM Report. HMS Penguin, Balmoral, NSW: Royal Australian Navy School of Underwater Medicine.

Dr. Carl Edmonds practices diving medicine near Sydney, Australia. He spent 9 years as the Officer in Charge of the Royal Australian Navy School of Underwater Medicine, and is the first author of one of the leading books on diving medicine.

Discussion after Dr. Edmonds

Dr. Peter B. Bennett (DAN, Durham, NC): In terms of what we've seen so far, I think Carl Edmonds is very straightforward. He always shoots very straight, and he is very logical and speaks common sense, if with a rather sharp tongue. Nevertheless, what he said made a lot of common sense.

The computers are brought in on the basis of making safer diving. If the computers let dives become very long, I would predict that we have a major problem in their use. They just will not do the job that is required; there is the impasse which the manufacturers face. The computers really are only as good as the physiology on which they are based, and we do not yet know what we are doing.

Mr. Bret C. Gilliam: At this point, because Carl Edmonds does have a sharp tongue, if this were Saturday Night Live, this would be where I would get up and insult him, but that's not really the case here. I think you may be unfamiliar with my report, which you referenced here as a "dive boat operator" (Gilliam, 1991); possibly you are not aware of another more recent one (Gilliam, 1992).

In fact, the first report was not done as a dive boat operator, it was as a diving ship operator, and our report was done primarily as a corporate management risk tool. It had nothing to do with trying to evaluate computers. All we were interested in was how many people do we put in the water, and what number or percentage of those people might suffer some various injury, whether it was a marine life injury or DCS incident.

We found after we analyzed the real dive statistics, that we had put almost 80,000 people in the water, and we produced an overall [DCS] incidence rate of approximately 0.2%. What was interesting to us, and why we reported it so widely, was the fact that all the computer users ended up absolutely accident-free, completely asymptomatic, and with no problems (Gilliam, 1992).

Now, that was done on the P-3 Bühlmann algorithm in a no-decompression model of the Dacor Microbrain; we felt that that was significant. We also looked at a lot of other data that included habits of dive planning, hydration, etc.

So, Dr. Edmonds is misrepresenting my report to a certain degree, and I just want to clarify that we were not out there to try to be a mouthpiece for computers, we were doing a risk management study.

Dr. Edmonds: I don't think I misrepresented your paper. I think everyone in this field is quoting that blasted paper as evidence of how safe computers are, and in fact, if you read that paper—and I suggest you read it again—you will realize that you have actually included an enormous safety factor. So, you are nowhere near testing the limits of the computers. You

even made your divers stay down at 4.5 meters until they ran out of air. So, that's a hell of a safety factor.

Mr. Gilliam: We did not attempt to validate computers.

Dr. Edmonds: In that case we should not be using the paper as evidence for the reliability of dive computers.

References for the discussion

- Gilliam BC. 1991. Computers vs. table usage. *Sources* 3(1):39-41.
- Gilliam BC. 1992. Evaluation of decompression sickness incidence in multi-day repetitive diving for 77,680 sport dives. In: Lang MA, Vann RD, eds. *Proceedings of Repetitive Diving Workshop. AAUSDSP-RDW-02-92*. Costa Mesa, CA: American Academy of Underwater Sciences.

BEHAVIOR OF DIVE COMPUTER ALGORITHMS IN REPETITIVE DIVES: EXPERIENCE AND NEEDED MODIFICATIONS

Albert A. Bühlmann

CH 8703 Erlenbach, Switzerland [deceased 1994]

Bühlmann AA. 1995. Behavior of dive computer algorithms in repetitive dives: Experience and needed modifications. In: Hamilton RW, ed. The effectiveness of dive computers in repetitive diving. UHMS Workshop 81(DC)6-1-94. Kensington, MD: Undersea and Hyperbaric Medical Soc.

Experimental dives and statistics (DAN, British Sub-Aqua Club) confirm a higher risk of decompression sickness for repetitive dives. Microbubbles in the venous blood obstructing a part of the lung capillaries produce ventilation-perfusion trouble, a right-left shunt well known in lung physiology. The arterial nitrogen pressure is for a few hours distinctly higher than the nitrogen pressure in the inspired air. Therefore the nitrogen elimination by respiration is retarded. Today it is possible to introduce algorithms in the basic model for this slowed-down desaturation. In the future, we should be able to simulate the effects of micro-bubble production during ascent even better. There are differences related to the profile of the previous dive, differences between a normal ascent and a fast ascent, and yo-yo dives. Diving in very cold water and diving with heavy work on bottom needs a longer decompression time than diving in warm water and performing light work. The new generation of dive computers for scuba divers is on the way.

Concept of the algorithms developed in Zürich

The incidence of decompression sickness (DCS) of the skin and/or the muscles after repetitive dives is higher than after the first dive. Microbubbles in the venous blood, obstructing a part of the lung capillaries, produce a ventilation-perfusion disturbance. The result is a right-to-left shunt, well known in lung-physiology. The arterial nitrogen pressure in relation to the profile of the preceded dive is for a few hours distinctly higher than the nitrogen pressure in the inspired air. The nitrogen elimination by respiration and the desaturation of the tissue is therefore retarded.

The risk of microbubble production increases with a high ascent speed and if the decompression rules are neglected. Microbubbles in a tissue reduce the perfusion of the affected tissue, resulting on a delayed nitrogen elimination.

The perfusion rates of the kidney, the liver and the central nervous system (CNS) are normally stable. On the other hand, there are substantial variations of the blood flow in skin and muscles. The physical activity during the dive is normally higher than during the interval at surface. The cooling of the skin and hypodermis depends on water temperature and diving time. These physiological facts are valid for all divers. Today it is possible to introduce algorithms in the basic model in regard to a right-to-left shunt and varying perfusion rates. Another point of view would be the individualization according to factors like gender, age, body weight, and hypersensitivity.

Our basic model to calculate saturation and desaturation is a multi-tissue model according to Haldane. With the help of IBM Switzerland, we realized in 1960 our first computer program to calculate saturation and desaturation with nitrogen and also with helium. The utility of the fundamental principles has been confirmed

by a successful dive to 250 meters, carried out in the same year by Hannes Keller.

The basic model (ZH-L16) uses 16 compartments with 16 half-value times (half times) for nitrogen, beginning with 4 or 5 min and going up to 635 min. That ensures a narrow network. (Details in Figure 1 and Figure 2.)

Figure 1 illustrates the multi-tissue model, related to the perfusion rates. Since 1960, we have calculated the decompression using a linear relationship between the absolute ambient pressure and the tolerated overpressure of the inert gas in the tissue. The leading idea is that a high perfusion rate goes along with a short half time and a high tolerance. The model is mathematically simple and transparent. A quick adaptation to new research data and altered diving practices is possible.

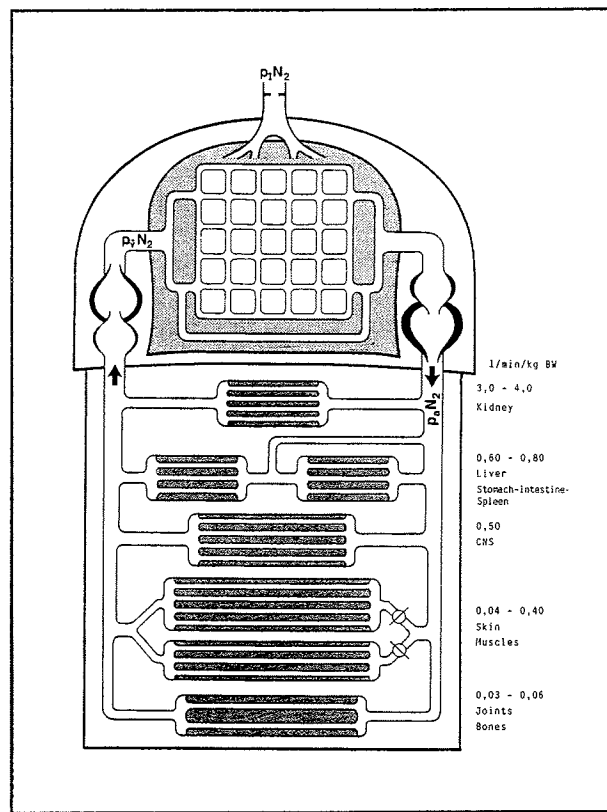

Figure 1. Schematic description of the multi-tissue model with lung, circulation, and 6 compartments, with different, partly varying perfusion rates. The perfusion rates correlate with compartment half times; these are on the right in liters/min/kg body weight.

All dive computers utilize the absolute ambient pressure and the time. In addition it is possible to take account of the water temperature and the air pressure in the tank. The skin temp-

Table I. Self-adapting dive computer.

Self-adapting to:	
☉	Micro-bubbles in the lung capillaries after normal ascent (right-to-left shunt)
☉	Micro-bubbles in arterial blood or tissues (fast ascent speed, neglected decompression stops)
☉	Skin perfusion (cold water, time)
☉	Muscle perfusion (work load, time)

erature can be estimated by water temperature and time. The air consumption is related to the work load. Modifications and supplements have made it possible for us to design the Self-Adapting Dive Computer without changing the principles of the basic model ZH-16.

The preliminary aim is to be self-adapting to four variable conditions, described in Table I.

Ernst Völlm and Markus Mock are the parents of the dive computer Aladin, and now they have developed the software for the new dive computer. My part in this process is to test the output of different model variations with well-documented dives, with and without symptoms of DCS. The output should be in concordance with the basic model and the physiological and medical experience, using lung and respiration, heart and circulation, and tissues with different and variable perfusion rates represented by different half times.

Comparison of total ascent times

Figures 2 to 4 demonstrate the total ascent times using the Aladin Pro (ZH-L6 2.1) and using a prototype of a Self-Adapting Dive Computer (ZH-8 ADT). The comparisons

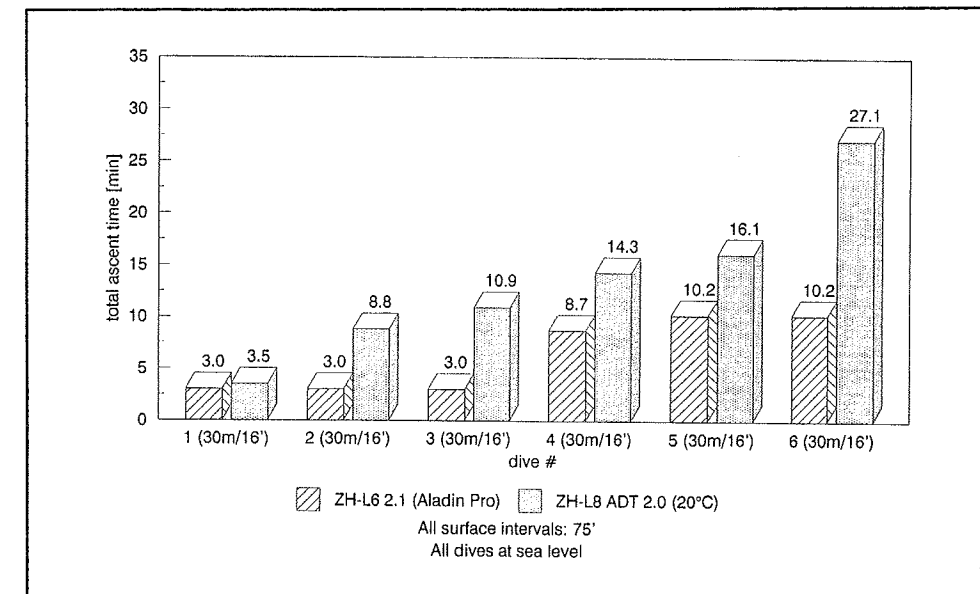

Figure 2. Comparison of ZH-L6 and ZH-L8 ADT: Extensive repetitive diving. Six dives to 30 msw, each with 16 min at 30 msw including 1 min descent time, with 75 min surface intervals. Comparison shows the total ascent time using the Aladin Pro (ZH-L6 2.1) and the Self-Adapting-Dive-Computer (ZH-L8 ADT).

show the ascent times for the same set of repetitive dive profiles.

Figure 2 illustrates repetitive dives at 30 meters; 16 minutes at 30 meters is an example of a no-stop or no-decompression dive. After a surface interval of 75 minutes, the Aladin Pro for the

Progressive obstruction of the lung capillaries has the risk that microbubbles can pass through the lungs and can thus be carried by the arterial blood to the tissues, causing a delayed desaturation. The algorithm ZH-L8 ADT takes into consideration this risk in extreme repetitive dives like those in Figure 2.

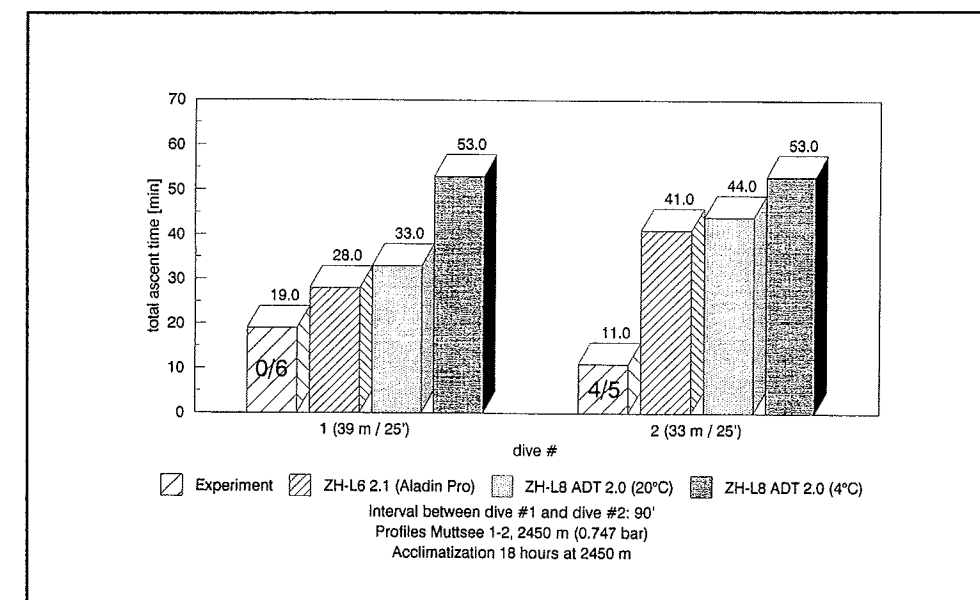

Figure 3. Two decompression dives at altitude in cold water. This is a comparison between the dives actually performed and the indications of the ZH-L6 2.1 and the ZH-L8 ADT. No symptoms of DCS were seen after the first dive; 4 of 5 divers had mild symptoms of DCS after the second dive.

first three dives calls for the same ascent time of 3 min. ZH-L8 ADT indicates for the first dive a total ascent time of 3.5 minutes, but following this a steady increase of the ascent times. Already the second dive needs a stop at 3 metres. The delayed nitrogen elimination as a result of microbubbles in the lung causing a right-to-left shunt is taken into consideration more strongly using the algorithm ZH-L8 ADT than using the Aladin Pro.

Diving in mountain lakes is popular in Switzerland, and is routine work for our Army and Police divers. In 1988, after an acclimatization for approximately 18 hours at 2450 meters above sea level, we performed 28 repetitive dives over two days. Decompressions for the first and the second dives were executed according to the basic model ZH-L16A (Bühlmann, 1993) without regarding the delay-

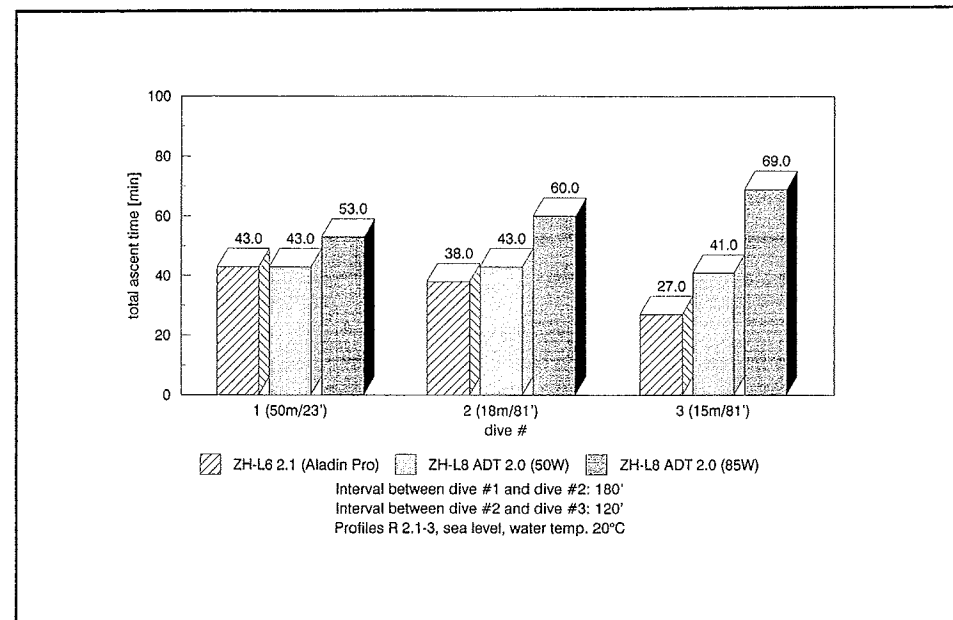

Figure 4. Three dives in warm water. Effect of a high work load on the total ascent time (see also Table 2).

ed nitrogen elimination expected to result from a right-to-left shunt. Using surface interval times of 180 up to 280 minutes no symptoms of DCS occurred in 23 divers, included 11 women. But after a surface interval of between 90 and 103 minutes, 4 of 5 divers had skin symptoms (red spots, itching) and mild pain in the shoulder (Bühlmann, 1989).

Figure 3 shows total ascent times. The real ascent time of the first dive (39 m/25 min) was 19 minutes. The Aladin Pro indicates a requirement of 28 minutes. The ZH-L8 ADT calls for 33 minutes, but 53 minutes if the real water temperature of 4°C is considered. Using a real total ascent time of 11 minutes for the second dive (33 m/25 min), we observed in 4 of 5 divers the mentioned mild symptoms of DCS. The Aladin Pro indicates 41 minutes, ZH-L8 ADT 44 minutes in warm water, but 53 minutes in very cold water.

The considerable difference between warm and cold water in the first dive and the smaller difference in the second dive should be explained. At the beginning of the first dive, temperature and the perfusion of the skin and therefore saturation with nitrogen are normal.

The rise is the result of the cumulative saturation of the working muscles. Compared are work loads of 50 watts (light) and 85 watts (hard) at bottom.

Such dives can be performed by professional divers. Table II compares the dive computer indications for the three dives with the rules of three standard air decompression tables.

The Canadian DCIEM Table is very conservative. If we take a bottom time of 20 minutes in place of 25 minutes at 51 meters, the DCIEM Table indicates 41 minutes ascent time for the first dive, and 43 minutes for the second dive. ZH-L8 ADT indicates for the second dive and light work practically the same total ascent time as the DCIEM Table. The Aladin Pro and the ZH-86 Table are adapted for light work.

All systems indicate longer total ascent times than the US Navy Table, revised 1958. The USN tables had predominant importance for us at the start of our activity in this field in 1960. In those days, we also consulted the old French "GERS" Tables. The tendency of the new tables and the two compared dive computers is clear: Longer total ascent times for all air dives than demanded by the US Navy tables.

The cooling and the delaying of the nitrogen elimination begins during the dive. Ninety minutes at surface are too short for a complete warm up. Therefore the nitrogen absorption in the skin is retarded during the second dive.

Figure 4 demonstrates the calculated effect of hard physical work during three dives in warm water. The increase of the total ascent time is significant for the second and third dive.

Table II. Total ascent times for different decompression tables and dive computers. Tables assumed dives of 51 msw/25 min.

	1st Dive	SI	2nd Dive	SI	3rd Dive
msw	50	0	18	0	15
min	23	180	81	120	81
Table					
US Navy (1958)	34		27		22
ZH-86 (1986)	45		29		28
DCIEM (1983)	59		49		*
Dive Computer					
ZH-L8 2.1 (1988)	43		38		27
ZH-L8 ADT (1993)					
Light work	43		43		41
Hard work	53		60		69

* No repetitive group available.

Dive recording

The knowledge of the real dive profile is useful for the evaluation of dive computers and also in case of an incident. The Self-Adapting Dive Computer (ZH-L8 ADT) stores the profiles up to 200 minutes of dive time. Using the data link and a PC, the dive profiles can be printed.

Figure 5 represents an example of rescue training in cold water. The ascent speed of 1.5 minutes from 27 meters to surface is too high and makes formation of microbubbles in the arterial blood possible. The dive instructor had no symptoms of gas embolism or DCS. The factors like cooling and work have only a small influence on the self-adapting system. The repeated fast ascents extend the ascent times of dives that follow.

Figure 6 illustrates the work load during a multilevel dive in warm water. Beginning at 8 meters, there is a high work load, lasting 10 min-

utes in diving down to 28 meters. During ascent there are only short periods of a high work load. There is no fast ascent and no neglected decompression stop. The cooling is mild, beginning after 18 minutes and increasing after 39 minutes (this is not clear on this reproduction). In this dive, the period between 6 minutes and 20 minutes dive time dominates the self-adapting system.

Conclusions

The decompression computer has changed recreational diving to a great extent. There are many more multilevel dives, repetitive dives, yo-yo dives, and prolonged times in the water. The incidence of DCS, mainly of the skin and/or the muscles, is higher after repetitive dives than after the first dive. Here I have compared the indications of a conventional dive computer like Aladin Pro, with the indications of a prototype of a new dive computer. The Self-Adapting Dive Computer (ZH-L8 ADT) is based on absolute pressure and time according to the basic algorithm ZH-L16, and it takes additional consideration of the water temperature and the air pressure in the tank, which are used to effect an adaptation of the ascent time. The comparison with three exemplary repetitive dives illustrates the effects of a high work load, very cold water, high ascent speed or neglected decompression stops, and right-to-left shunt caused by micro bubbles in the lung capillaries after the preceding dive. The algorithm ZH-L8 ADT is not only a needed modification, it is an essential improvement.

In our opinion, the Self-Adapting Dive Computer represents a new generation of dive computers. Improvements are probable, however.

References

- Bühlmann AA. 1993. Tauchmedizin. 3rd edition. Berlin Heidelberg New York: Springer-Verlag.
- Bühlmann AA. 1989 Dec. Flying after diving. In: Sheffield PJ, editor. Flying after diving. 77-(FLYDIV)12/1/89. Bethesda, MD: Undersea Hyperbaric Med Soc. Pp 99-105, 215-222.

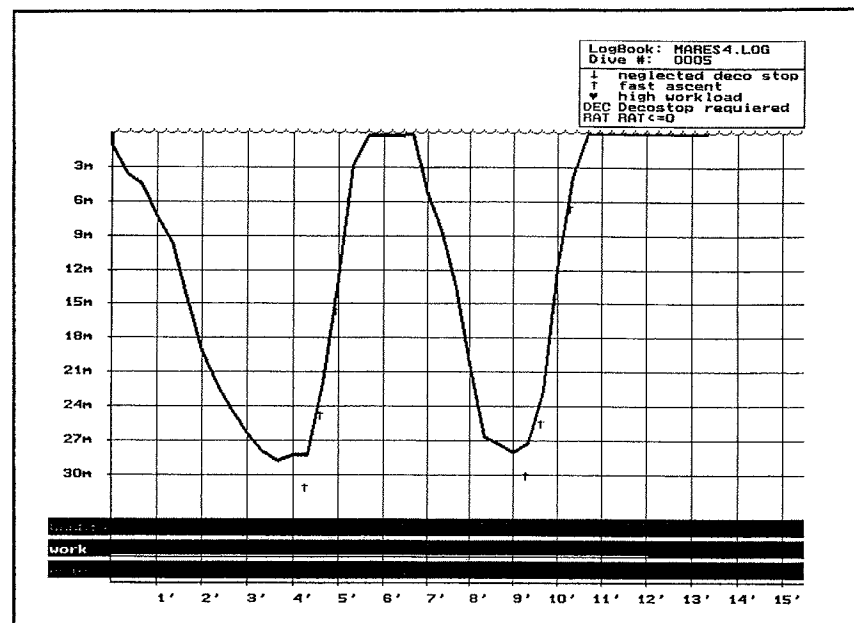

Figure 5. A multilevel dive in warm water with a high work load lasting 10 minutes between 8 and 28 msw.

Hamilton RW, Rogers RE, Powell MR, Vann RD. 1994. Development and validation of no-stop decompression procedures for recreational diving: The DSAT Recreational Dive Planner. Santa Ana, CA: Diving Science and Technology.

The self-adapting dive computer is now available as the Uwatech Air X.

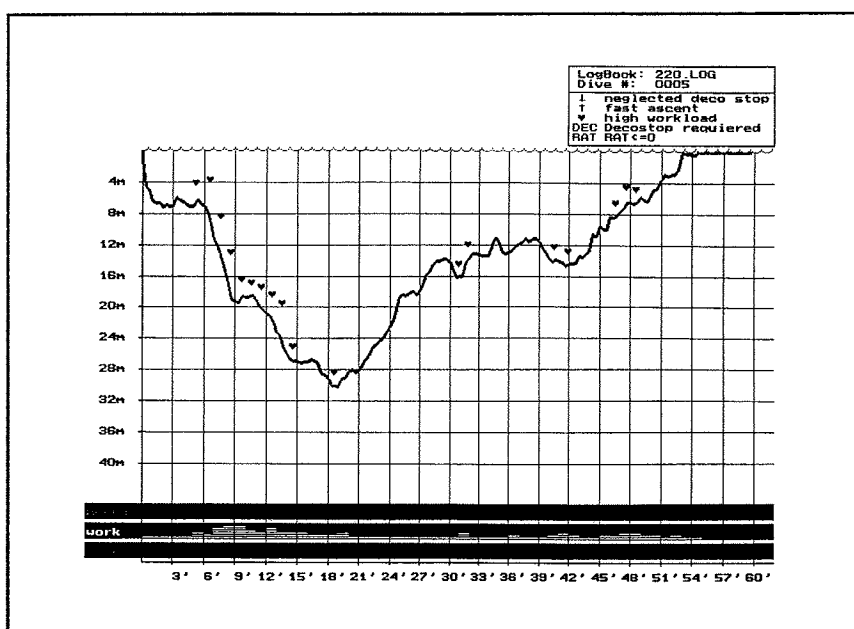

Figure 6. Real dive profiles stored with ZH-L8 ADT. Rescue training in cold water. The repeated fast ascent—1.5 minutes from 27 msw to surface—causes slower ascent times for following dives that follow, as a result of microbubbles in the arterial blood.

Dr. Albert A. Bühlmann died on 1994 March 16. In real life he was a respiratory pathophysiological at the University Hospital in Zürich, but for the last 35 years had become one of the leading workers in the field of decompression. He began working with Hannes Keller in developing early procedures for deep commercial short-duration dives, and later developed state-of-the-art methods for minimizing HPNS and for decompressing from saturation dives. He always had the safety of recreational divers in mind, and in doing tables for diving in mountain lakes he became the leading authority in diving at altitude.

He provided the algorithms for several dive computers, including the Aladin Pro, the Dacor Microbrain, and the Self-Adapting Dive Computer mentioned here. His methods were more practical and empirical than mathematical, and although he disclaimed any expertise in math his algorithms, in part because they have been published, have been adopted for numerous other dive computers and computational programs.

Editors note: Readers are reminded that all Dr. Bühlmann's work with recreational diving is based on fresh water and uses fresh water pressure units, and the dive computers that are based on his work also use fresh water units. We strongly discourage the use of fresh water units such as "mfw" ("metres of fresh water") because we have too many units already, but especially they should not be used without a conversion factor to SI units. A foot of fresh water is generally regarded as 1/34 atmosphere but we do not have the exact SI value.

Discussion after Dr. Bühlmann

Dr. Peter B. Bennett (DAN, Durham, NC): Let me say, first of all, I think it is good to see somebody starting to look at several dives a day, because we know that in recreational diving divers are doing anywhere from three to six dives a day, maybe five or six, for 10 days in a row. We do not believe that the computers are good enough for that at the present time.

I think Professor Bühlmann's paper is very interesting, but it is doing exactly what anybody here who has been in decompression a long time would predict, that if you add more time you are going to get a safer computer.

Dr. Michael R. Powell (NASA, Houston): I have a question for Dr. Bühlmann. You mentioned arterial gas bubbles being present, although you said this is theoretical rather than measured. What evidence do you have that they are there? I ask this because in the 20 years that I have worked both visually and with ultrasound, with rats, rabbits, sheep, and pigs, I have not seen any evidence of arterial gas bubbles until the animals are *in extremis*, basically almost dead.

Dr. Albert A. Bühlmann: The bubbles are not yet measured.

Regarding the self-adapting system we say if the theoretical limit is, let us say, 10 percent or 15 percent over, then we delay the desaturation. That's all. If you go up in one minute from 20 meters it's possible to have some bubbles, but it's not possible to measure them. There must be bubbles. If you come up from a hundred meters to surface, we have such cases. Then you have plenty of bubbles, but they are dead divers.

It is the same with the temperature. We have the dive computer measure the temperature of the water, and we presume that this cools the diver over time. We have measured the skin temperature in experiments and we looked at the time course, how long it took to rewarm during the surface interval. Then we have the algorithm delay the desaturation. That's all.

Dr. Powell: I understand. I have similar concept about the bubbles, although I would not expect that the asymmetry in gas uptake and elimination was caused by arterial bubbles, but rather by bubbles present in the tissue itself. These serve as the source on the next dive for gas, or bubble nuclei, and this progresses. I think here we are discussing the results of some of that, namely you cannot make repetitive dives on and on and on because you will get probably some degree of gas phase formation. When we tried that with the PADI/DSAT test series (Hamilton, et al, 1994), we did encounter some of that, although there were only a few divers in that one particular test.

Dr. Bühlmann: I agree. Gas bubble formation during fast ascent, missed decompression, etc., this is the same.

Dr. Alf O. Brubakk (SINTEF, Trondheim, Norway): Two points to make on that. First of all, you do not need any gas bubbles at all to have asymmetry. An example is a saturation dive. It is quite easy to calculate. In a non-saturation dive the lower compartment tensions as you decompress, in relation to compressing, will give you quite a substantial asymmetry. So, one of the points about this repetitive diving is that if you do not take into account the asymmetry that is caused simply by the gas tensions, then you run into trouble.

My second point is about arterial bubbles. It is certainly not true that you will not see arterial bubbles. My main experience in looking for them is in deep saturation dives. To make it very general, I can say that any ascent from 300 to 500 meters on heliox produced arterial gas bubbles detectable by ultrasound in almost every diver I have looked at.

And as I repeat again, I hope that somebody else will repeat my experiments because I would like to have someone else see this besides me; for some strange reason nobody wants to look. I have also seen arterial bubbles occasionally on shallower dives. I believe the reason that we see them easier on deep dives is simply that we have higher gas tensions, and the gas bubbles live longer. So, we see them more easily. It

might also be a cavitation phenomenon in the arterial system. So, I believe arterial gas bubbles are probably much more common than we used to believe.

Dr. Russell E. Peterson: I have a question for Dr. Bühlmann. Concerning the latest of your models which use inputs of various physiological parameters, specifically with respect to temperature, you indicated that when you had a cold dive, then during the surface interval you said it was too short for the diver to warm up fully, so the uptake on the next dive was at a reduced rate. So I wonder how you are determining the temperature, and how you account for things that the diver might do when she reaches the surface to warm herself up. Having a hot drink, wrapping up in a blanket or something. Is there any way you can deal with the variability of what the diver might do on the surface?

Dr. Bühlmann: I am not a diver. That is a difference between Dr. Hahn and me. I cannot say personally what is the best. We made this measurement in February after a stay in a room before going out—but the stay in the room was not very long. Then we looked at the skin temperature, how it was progressing, and there we saw after 60 or 80 minutes that skin is still not normal.

But I cannot say what is best. We have the problem with dry suits and wet suits. With dry suits we have more decompression troubles with the skin and with shoulder pain than with wet suits. I have no good explanation.

Dr. Peterson: Then, rather than have a model that can reduce uptake based on some temperature parameter, might not it be more conservative to always assume that uptake is not unimpaired or at any sort of reduced rate, but that perhaps elimination can be effected (reduced) by cold temperatures during the dive?

Dr. Bühlmann: We have time limits from the beginning of the dive, in the water. Let us say the water is 4° C, but the effect begins 10 to 20 minutes later, not at the moment the temperature is 4 degrees. There is always a time factor, and a quantification of all these parameters. That is a problem for me and for others working on this.

Reference for the discussion

Hamilton RW, Rogers RE, Powell MR, Vann RD. 1994. Development and validation of no-stop decompression procedures for recreational diving: The DSAT Recreational Dive Planner. Santa Ana, CA: Diving Science and Technology.

WORKMAN-BÜHLMANN ALGORITHM FOR DIVE COMPUTERS: A CRITICAL ANALYSIS

Max H. Hahn

Federation of German Sport Divers, D-41564 Kaarst, Germany

Hahn MH. 1995. Workman-Bühlmann algorithm for dive computers: A critical analysis. In: Hamilton RW, ed. *The effectiveness of dive computers in repetitive diving*. UHMS Workshop 81(DC)6-1-94. Kensington, MD: Undersea and Hyperbaric Medical Soc.

Many dive computers use the Bühlmann algorithm to determine no-decompression limits (NDL's) or decompression schedules. This algorithm assumes the "allowed" gas loadings in "double exponential" compartments (defined by a single halftime each, with symmetrical gas uptake and elimination) to be linear functions of the ambient pressure. It is mathematically identical with the model of Workman. Its deficiencies, already discussed earlier, can be demonstrated quantitatively. For published dive profiles with known outcome, we computed the tolerance levels using recently published coefficients. Comparison includes risk calculations with U.S. Naval Medical Research Institute expressions and confidence limits where applicable. The following conclusions may be drawn:

- Tolerance coefficients allowing rather safe NDL's for 60-80 fsw lead to unacceptably high risks for dives requiring long decompressions.
- Retarded off-gassing due to bubbles after a preceding dive is not properly accounted for.
- Many consecutive shallow dives (e.g., such as in fish farming), although prone to DCS, stay far below the tolerance limits of the algorithm.
- No specific "penalty" for risky "deeper-than-previous" dives can be derived from this algorithm.

Introduction

Due to the simplicity of its theoretical concept as well as the ease of computation, the decompression model published by Workman (Workman, 1965) and—mathematically identical—by Bühlmann (Bühlmann, 1982, 1984) is widely used in today's dive computers. Workman assumed the maximum "allowed" inert gas loadings M in monoexponential, parallel compartments to be linear functions of depth d .

$$M = (m \times d) + M_0$$

The coefficients m (slope) and M_0 (allowed gas loading at surface) are derived empirically from decompression sickness (DCS) symptom statistics and/or bubble measurements for defined pressure/time profiles with human subjects.

Bühlmann defines the minimum tolerated ambient pressure $p_{amb,tol}$ as a linear function of the partial pressure or gas loading g in the compartments.

$$p_{amb,tol} = b \times (g - a)$$

Sets of coefficients a and b , mostly derived from DCS symptoms diagnosed after dry chamber exposures of human subjects, are published (Bühlmann, 1993). Conversion of Workman coefficients to Bühlmann coefficients is given by

$$b = 1/m$$

and

$$a = M_0 - m \times p_{amb,surf}$$

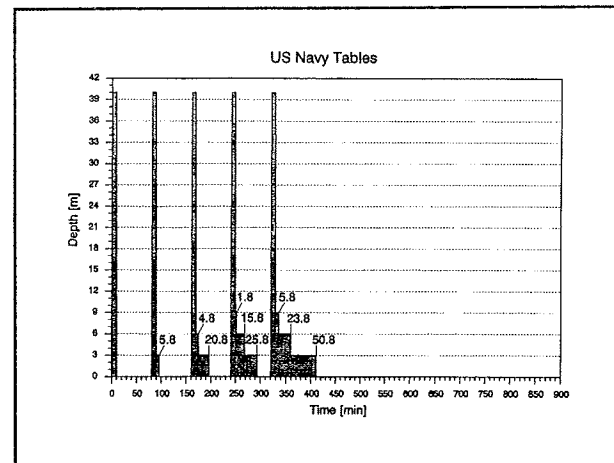

Figure 1. Response of US Navy air decompression tables to yo-yo dives, with descents in one minute to 40 m, holds at 40 m for 7.5 minutes, and ascents at 18 m/min. Descents repeated every 80 minutes.

with $P_{amb,surf}$ the ambient pressure at zero depth.

Deficiencies of the Workman-Bühlmann model

Comparison of chamber dives and their outcome with results of computations with the Bühlmann model and its most recent and most conservative parameter set ZH-L16C (for dive computers), backed up by risk estimations with the most recent NMRI model and parameters (with good significance for "air only" dives) reveals some deficiencies of this model.

The first stems from properties of the underlying differential equation: Monoexponential compartments, describing in- and outflow of dissolved gas only, behave like an electrical low pass filter (resistor + capacitor). That is, yo-yo diving—the equivalent of a high frequency—does not provoke a proper reaction of the slow compartments, whose low tolerances might otherwise stop too many repetitions.

Figures 1, 2, and 3 (Hahn, 1995; Hahn, 1991), first shown as posters in 1989 (Hahn, 1989), demonstrate the differences between the US Navy tables, the DCIEM model (Nishi and Lauckner, 1984), and two dive computers which are still on sale that operate with derivatives of

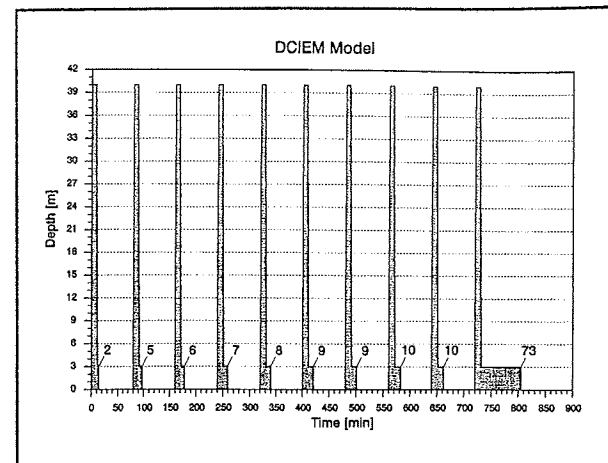

Figure 2. Response of DCIEM model (Nishi and Lauckner, 1984) to yo-yo dives as in Figure 1, but for slower ascents, 10 msw/min.

the Bühlmann model, the Uwatech AladinPro and the Dacor Microbrain.

Another set of comparisons, Figures 4, 5, and 6, shows profiles for which limited dive outcome data are available. Decompression profiles calculated with ZHL-16C are in dotted lines; these all result in shorter decompressions than the actual dives, which had rather high decompression incidences. The binomial confidence limits for the actual sample data are shown; these show the range within which we can be 95% confident that the true incidence of that sample would fall. Probabilities (P_{DCS}) estimated using

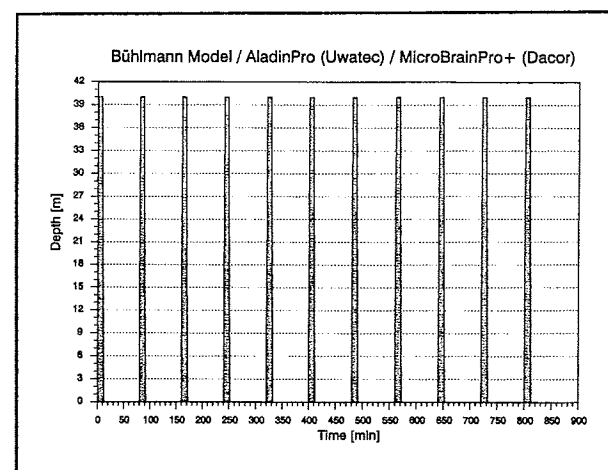

Figure 3. Response of the Bühlmann model (Bühlmann, 1993), and two dive computers to yo-yo dives as in Figure 2.

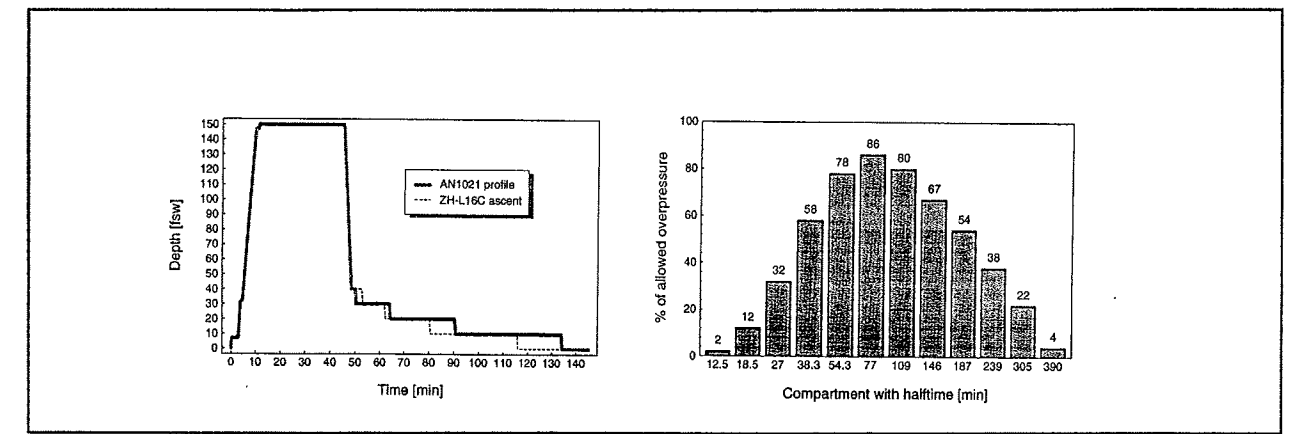

Figure 4. US NEDU wet chamber dive 150 fsw/35.3 min. Left, heavy line shows dive AN1021 (Weathersby et al, 1992) as performed; dashed line is response of model ZH-L16C (Bühlmann, 1993) to same profile, showing a shorter decompression. Outcome, DCS/dives = 1/10 = 10%; 95% confidence limits for 1 of 10 = 0.25–44.5%. DCS risk calculated according to NMRI risk estimation model EE2-2b (Parker et al, 1992): AN1021 profile P_{DCS} = 7.62%; ZH-L16C ascent P_{DCS} = 8.60%. Right, compartment overpressure for AN1021 profile at final surfacing, in % of "allowed" overpressure according to ZH-L16C.

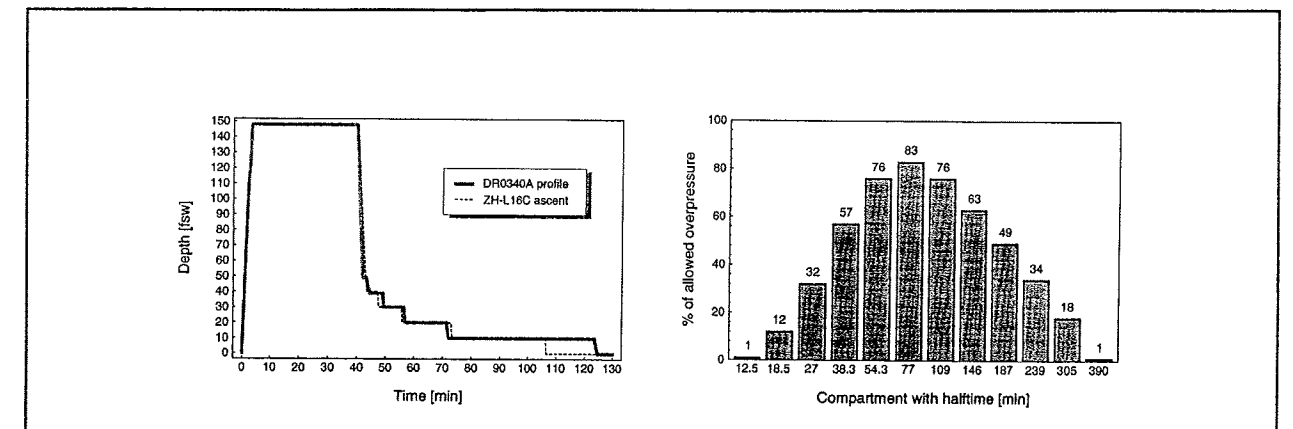

Figure 5. DCIEM dry chamber dive 148 fsw/36.7 min. Left, heavy line is DCIEM dry chamber dive DR0340A (Weathersby et al, 1992), dashed line is response of model ZH-L16C (Bühlmann, 1993) to this profile. DCS/dives = 3/11 = 27.27%; 95% confidence limits 6.02–60.97%. Calculated risk according to NMRI risk estimation model EE2 (2b) (Parker et al, 1992): DR0340A profile P_{DCS} = 7.55%; ZH-L16C ascent P_{DCS} = 8.39%. Right, compartment overpressures for this profile at final surfacing, in % of "allowed" overpressure according to ZH-L16C "Computer" model (Bühlmann, 1993).

the USN procedures (Parker et al, 1992) corroborate the observed incidences, and show the degree that the ZHL-16C decompressions are less conservative than the original dives.

A second problem arises when slower compartments, which are "leading" after dives with total ascents longer than 30 min (see Figures 4, 5, and 6), are given tolerance coefficients to limit residual DCS risks (Parker et al, 1992; Weathersby et al, 1992) of such dives to, say, 2%. Then no-stop or no-decompression limits (NDL) for shallow dives get so short they are

not well accepted by the recreational diving community and thus not by the dive computer manufacturers. Table I and Figure 7 show how residual risks increase for shallow dives with bottom times equal to NDLs of the Bühlmann model, compared to the DCIEM model. Additionally, the outcome of very deep dives (see Figure 8) nourishes some doubts as to whether the linear depth dependence of supersaturation limits ensures depth-independent residual risks. It should be made clear that these dives are high risk dives, both due to

Table I. Residual risks, estimated with model EE2-2b (Parker et al, 1992), for dives with bottom time equal to NDL's (no-stop limits) of ZH-L16C and DCIEM models; descents 48 msw/min (see also Figure 7).

No-stop limits for Bühlmann and DCIEM models														
Depth (m) (fsw)*	12	15	18	21	24	27	30	33	36	39	42	45	48	51
ZH-L16C time (min)	187	93	63	44	33	25	20	17	14	12	10	9	8	7
ZH-L16C Risk (%)	4.4	3.7	3.4	2.8	2.4	2.1	2.0	2.0	2.0	2.0	2.1	2.1	2.1	2.2
DCIEM time (min)	189	67	38	26	20	16	13	11	10	9	8	7	6	6
DCIEM risk (%)	4.4	2.2	1.4	1.2	1.1	1.2	1.3	1.4	1.5	1.6	1.7	1.8	1.8	1.9

* fsw values rounded to integers

decompression and to the narcosis that the given depth range would involve.

Thirdly, the outcome of specific fish-farming dives (Douglas and Milne, 1991) contrasts sharply to predictions based on Workman-Bühlmann algorithms (Figure 9). However, since these kinds of profiles were not contained in the data base for maximum likelihood risk calculations (Weathersby et al, 1992), today's NMRI models cannot be expected to estimate these risks properly.

Finally, repetitive dives with increasing depth are considered risky, for good reasons. Bubbles could be heard in Doppler monitoring after a repetitive descent to 40 msw (Hahn et al, 1985). After holding for 60 min at 18 msw (i.e., near the 63-min NDL of Bühlmann's model) and taking a surface interval of 60 min, the diver is offered a NDL of 13 min at 36 msw by this model, i.e., almost as much as without the preceding dive. In reality, the second dive would plunge just into the maximum bubble outburst of the first one. Even for divers without a pat-

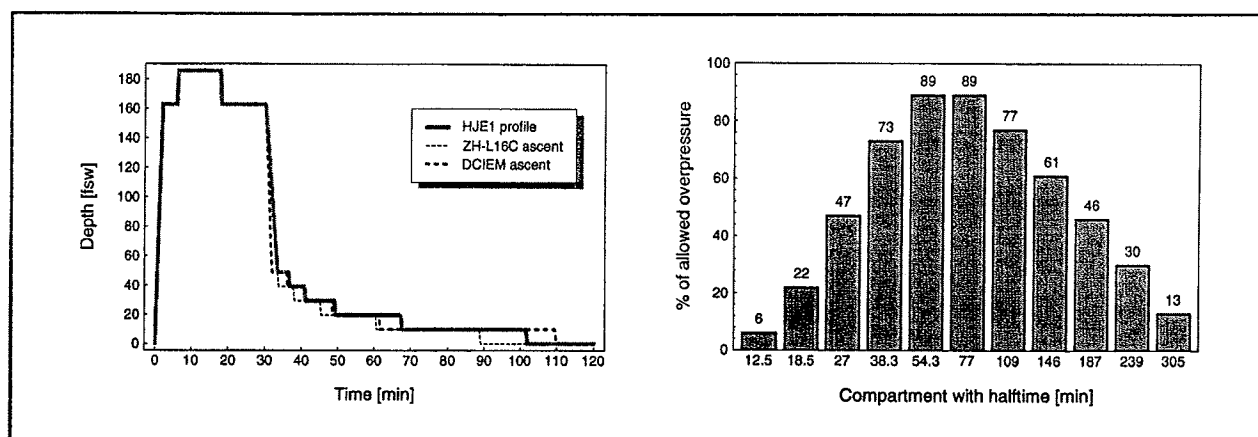

Figure 6. BLFS chamber multilevel dive, 186 fsw. Left, heavy line shows multilevel chamber dive HJE1 of the Bundes-Lehr-und Forschungs-Stätte of DLRG, Berlin (Hahn, 1986); light dashed line is response of model ZH-L16C (Bühlmann, 1993) and heavy dashes show how the DCIEM model would ascend from this exposure (Nishi and Lauckner, 1984). Outcome, DCS / dives = 2/15* = 13.3%; 95% confidence limits = 1.7-40.5%. Calculated risk according to NMRI risk estimation model EE2-2b (Parker et al, 1992): HJE1 profile P_{DCS} = 6.97%; ZH-L16C ascent P_{DCS} = 7.59%; DCIEM ascent P_{DCS} = 6.59%. Right, compartment overpressure for HJE1 profile at final surfacing, in % of 'allowed' overpressure according to ZH-L16C "Computer" model (Bühlmann, 1993). * plus 4 marginal cases (skin rashes).

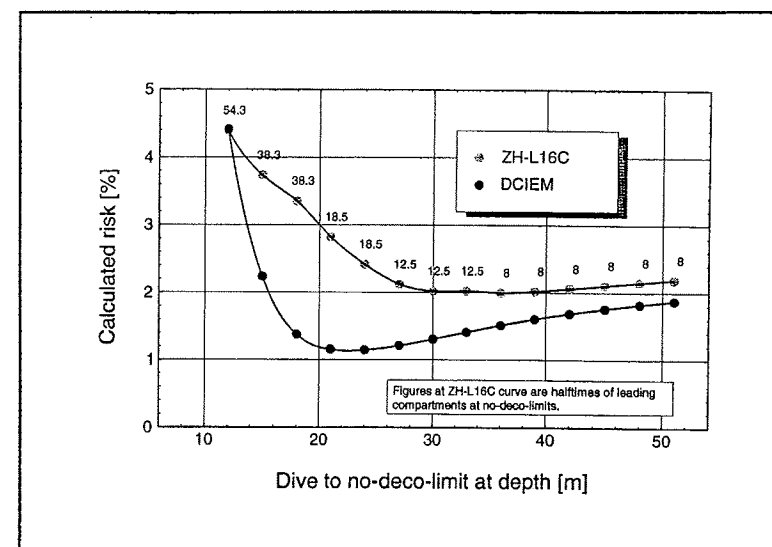

Figure 7. Risk analysis of decompression models. Comparison of residual risks, calculated with model EE2-2b (Parker et al, 1992) of DCIEM and model ZH-L16C (Bühlmann, 1993). Lower curve shows % risk of DCS in DCIEM tables, upper curve shows risk of ZH-L16C; figures are half times of controlling compartments.

ent foramen ovale, this would bear apparent risks.

Conclusions

The now common use of dive computers, mainly utilizing some proprietary variations of the above-explained model, has apparently not

significantly increased the DCS cases per dive (Hahn, 1995). Nevertheless, the absolute number of cases is still growing because recreational scuba diving is expanding by two digit percentage rates per year. This fact also leads to a steadily growing fraction of novices in the diving community, often with both low willingness to read and limited ability to understand exhaustive dive computer manuals. Therefore progress in processor power as well as RAM and ROM capacities in wrist worn dive computers should be utilized predominantly for the implementation of more advanced decompression models than for further elongation of the sales-promoting "feature" list. Most of the "don't," "avoid," and "beware of" rules—which at best

are found in dive computer manuals but not yet in computers, after years of sales—in the divers' press could be integrated into proper computational algorithms. This also would help get rid of the helpless "out-of-range" rules by which some instruments essentially abandon the diver by turning off computation and leaving the diver with nothing more than a depth gauge and a

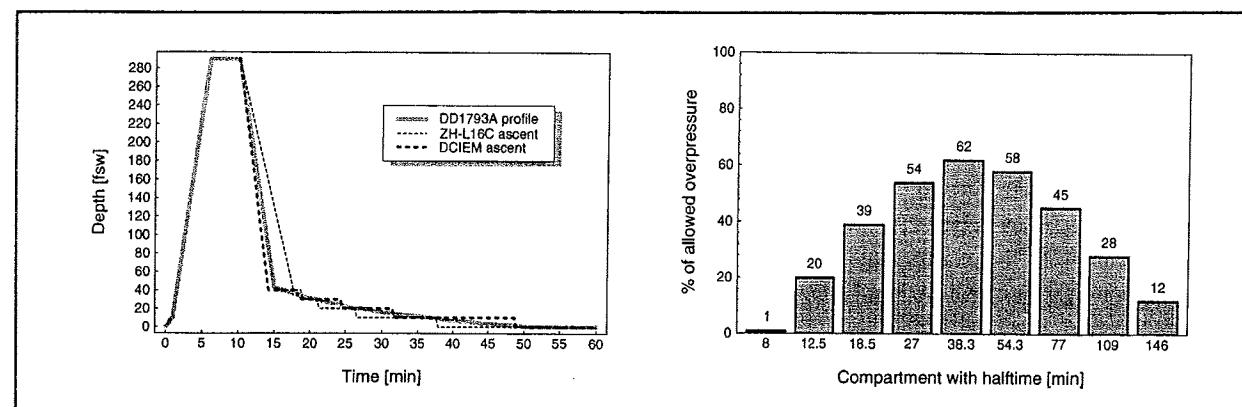

Figure 8. Response of DCIEM and ZH-L16C models to a 290 fsw/4 min dry chamber dive with 2 cases of DCS in 5 exposures (95% confidence limits 5.27-85.34%). Left, heavy line is DCIEM dry chamber dive DD1793A (Weathersby et al, 1992), light dashed line is response of model ZH-L16C (Bühlmann, 1993) to this profile, and heavy dashed line is DCIEM ascent (Nishi and Lauckner, 1984); 95% confidence limits 6.02-60.97%. Calculated risk according to NMRI risk estimation model EE2-2b (Parker et al, 1992): DD1793A profile P_{DCS} = 3.26%; ZH-L16C ascent P_{DCS} = 4.05%; DCIEM ascent P_{DCS} = 3.20%. Lower 95% confidence limit is above risk estimation with model EE2-2b. Right figure shows calculated compartment overpressure for DD1793A in percentage of allowed according to ZH-L16C (Bühlmann, 1993).

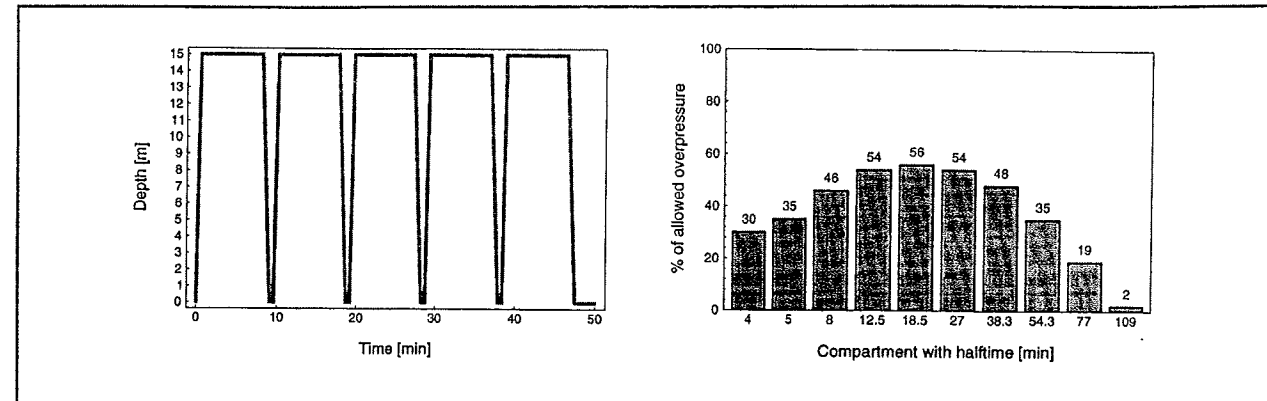

Figure 9. Fish-farming yo-yo profile resulting in DCS (left). Musculoskeletal DCS successfully treated with US Navy Table 6 (Douglas and Milne, 1991). Right, the comparatively low supersaturation by ZH-L16C model (Bühlmann, 1993).

timer when certain limits are exceeded.

I see one of the problems is in the politics, the policy of some of the diving organizations that says never to do "decompression dives." That means the customer has a tendency to buy the computer with the longest no-d limit. This is not so strict in Europe, where decompression dives are not specifically forbidden and are done regularly, but in the United States as far as I know this is one of the problems.

I have developed a model which takes into account every metre of ascent, and limits the diver according to that. This deals directly with yo-yo diving, and also would probably help to avoid the problems which obviously exist if you go rather deep, especially if it is repeated.

Acknowledgements

I gratefully acknowledge the helpful communications with Mr. Erich C. Parker, NMRI, Bethesda, and I am indebted to my son Bernhard M. Hahn for writing a Mathematica program to use Parker's model EE2 (2b) and for designing the figures.

References

- Bühlmann, AA. 1982. Experimentelle Grundlagen der risikoarmen Dekompression. Schweiz Med Wochenschr 112:48-59.
 Bühlmann AA. 1984. Decompression: Decompression sickness. Berlin: Springer Verlag.

- Bühlmann, AA, ed. 1993. Tauchmedizin. 3rd ed. Berlin: Springer-Verlag.
 Douglas JDM, Milne AH. 1991. Decompression sickness in fish farm workers: A new occupational hazard. Brit Med J 302:1244-5.
 Hahn MH. 1986. Dekoforschung: Warum und wie? Der Tauchlehrer (Essen, Germany; VDTL). 4(1):25-27.
 ✓ Hahn MH. 1989. Responses of decompression computers, tables and models to "yo-yo" diving. Undersea Biomed Res 16 (Suppl.):26.
 Hahn MH. 1991. Dekompression und Tauchcomputer. In: Roggenbach HJ, ed. Tauchmedizinische Fortbildung. Stuttgart: Verlag Stephanie Naglschmid.
 ✓ Hahn MH. 1995. Dive computers: Today and tomorrow. In: Wendling J and Schmutz J, eds. Safety limits of dive computers. Basel: Foundation for Hyperbaric Medicine.
 Hahn MH, Hampe P, John S. 1985. Wet chamber dives to test algorithms for electronic decompression meters. In: Örnhausen H, ed. Proceedings XIth Annual Meeting of EUBS. FOA Report C50021-H1. Stockholm: National Defense Research Establishment.
 Nishi RY, Lauckner GR. 1984. Development of the DCIEM 1983 decompression model for compressed air diving. DCIEM No. 84-R-44. Downsview, Canada: Defence and Civil Institute of Environmental Medicine.
 Parker EC, Survanshi SS, Weathersby PK, Thalmann ED. 1992. Statistically based decompression tables VIII: Linear-exponential kinetics. NMRI Report 92-73. Bethesda: Naval Medical Research Institute.
 Weathersby PK, Survanshi SS, Nishi RY, Thalmann ED. 1992. Statistically based decompression tables VII: Selection and treatment of primary air and

N₂O data. NMRI Report 92-85. Bethesda: Naval Medical Research Institute.

Workman RD. 1965. Calculation of decompression schedules for nitrogen-oxygen and helium-oxygen dives. Research Report 6-65. Washington: US Navy Experimental Diving Unit.

Max Hahn is a physicist retired from work as an electron microscopist. He is an avid diver himself and is the scientific advisor for Verband Deutscher Sporttaucher e.V., the German Sport Diver Federation. He has prepared algorithms for dive computers.

MANIFESTATION OF DECOMPRESSION ILLNESS IN DIVERS USING DIVE COMPUTERS

Guy de Lisle Dear, Petar J. Denoble, and Richard D. Vann.

Divers Alert Network (DAN) and F.G. Hall Hyper/Hypobaric Center, Department of Anesthesiology, Duke University Medical Center, Durham, NC

Dear G de L, Denoble P, Vann RD. 1995. Manifestation of decompression illness in divers using dive computers. In: Hamilton RW, ed. The effectiveness of dive computers in repetitive diving. UHMS Workshop 81(DC)6-1-94. Kensington, MD: Undersea and Hyperbaric Medical Soc.

We analyzed the symptoms and other parameters from 1825 decompression illness (DCI) case reports in the Divers Alert Network database, 1987 thru 1991, comparing the manifestations of DCI (Table I). These were subdivided into two groups, those who used dive computers (DC) and those who did not, table divers (TD). The number of reports from divers using DC's has increased over the years to 45.6% in 1991. In the DC group there were more experienced, older, and male divers. The average dive profile of DC users was deeper, of longer duration, and consisted of more repetitive dives. A combination of the most commonly presenting symptoms as well

Table I

	% of DC users	% of TDivers
Pain	68.71	60.53
Numbness	51.99	56.69
Weakness	23.77	26.85
Paralysis	4.45	7.50
Dizziness	19.33	22.68
Visual disturbance	7.98	6.31
Bladder problems	2.30	2.56
DCI Type I	26.69	17.14
DCI Type II	65.80	63.60
AGE	7.52	19.27
Residual Pain	22.70	14.83
Residual Neurological	25.31	28.99

as those which reflected more serious injury were examined. Neurological symptoms predominated in both groups but were more common in TD, while limb pain only was more frequent in DC divers. AGE was diagnosed more often in TD. Onset times for the more serious symptoms were shorter than for pain or numbness. Residual symptoms after treatment were present in 48% of DC users. A prospective study which includes safe dives as well as DCI is required to show the significance of these differences as well as the true incidence of DCI in DC users;

this is underway. The information presented here confirms the ubiquity of neurological symptoms in DCI in recreational divers. It also indicates there are differences in the type of injury, time course, and outcome suffered by divers using dive computers or tables.

Introduction and methods

We analyzed the characteristics of divers in the Divers Alert Network database of diving mishaps to see if we could find differences between

the manifestation of decompression illness in dive computer users (DC) or table divers (TD). We also tried to determine any effect of repetitive diving. The data we report upon were provided from 1987-1991 by 136 recom-

pression facilities in the United States and Caribbean. The patients and medical personnel completing the forms were interviewed by DAN personnel after the initial reports were submitted. About half the submitted reports were rejected as incomplete or ambiguous. There were finally 1825 reports which were accepted for analysis by a combination of descriptive statistics and logistic regression.

Results

The distribution of cases by year and by presumptive classical diagnosis is shown in Figure 1. The diagnosis of arterial gas embolism (AGE) has been fairly constant over the years with 54 cases in 1991. The diagnosis of DCS II (neurological symptoms) was made in a majority of cases reported in each year. The

DAN DCI data base summary					
	1987	1988	1989	1990	1991
AGE	52	46	53	73	54
DCS I	46	60	87	100	79
DCS II	169	160	251	286	302
Total	270	268	391	459	435

Figure 1. Distribution of classical symptoms of DCI over the survey period, 1987-1991. AGE = arterial gas embolism; DCS I = pain and itching only; DCS II = neurological symptoms.

percentage of decompression illness cases in computer divers has generally increased from 1987 to 1991 (Figure 2) and is now at around 45%. This may reflect increased computer use in the diving population.

We examined differences in the diving patterns of table and computer divers. The mean number of dives in a seven day period was 2.9 in TD and 4.4 in DC. The maximum number of dives in that period was 18 in TD and 26 in DC. The mean number of days of diving was approximately the same, TD 1.6 and DC 1.9. These differences were not significant but suggest that, in general, those who used computers made more repetitive, multi-day dives than the table divers.

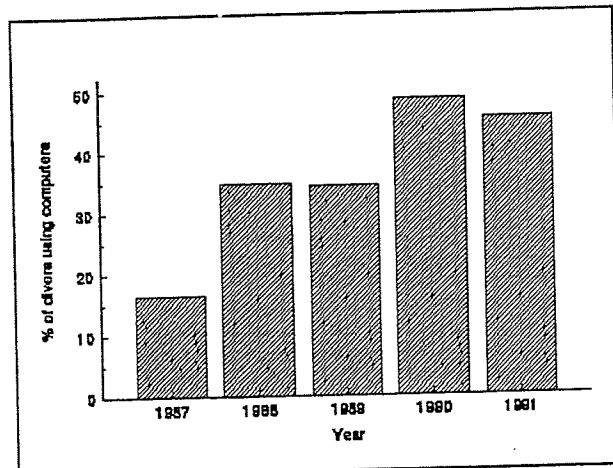

Figure 2. Percentage of DAN cases who were computer users over the survey period.

The trend is for computer divers to dive significantly deeper and longer. Approximately 7% of DC divers with DCI dived to greater than 130 fsw, which is the recommended maximum depth for sport divers on air (Figure 3). Table divers tended to dive considerably shallower. We collect, retrospectively, bottom time, maximum depth, and surface interval, but this does not indicate an accurate measure of dive severity as most dives are multilevel, especially in the DC group. We ask how many dives were made over how many days but can only characterize the dives as single or repetitive, multilevel or square, no-stop or decompression, and single day or multi-day. We hope to improve our dive profile data in an ongoing project that will record pressure-time profiles with computers.

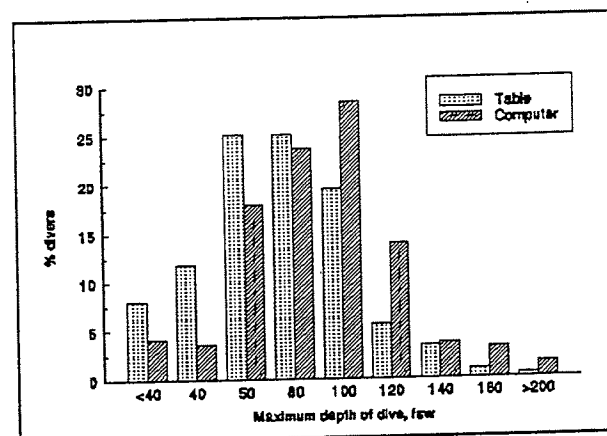

Figure 3. Maximum depth of dives in each survey group. Shows percentage of divers using dive computers and divers using tables.

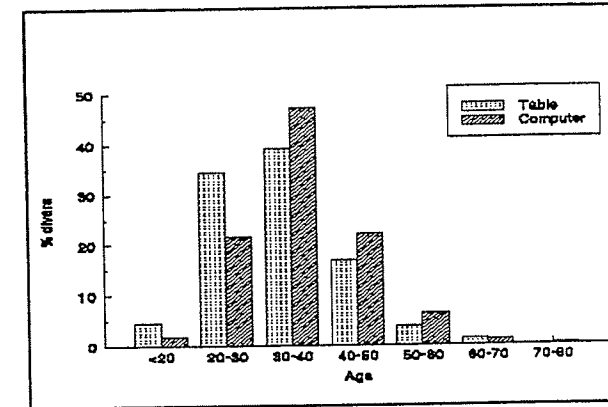

Figure 4. Age range of diver groups, by percentage. Dive computer users are generally older than table users.

We next considered the demographics of table and computer users. There is a clear trend for computer divers to be older, on the average, most greater than 40. DC divers had a mean of 35.9 years (range 11-71) whereas TD had a mean of 32.9 years (range 12-64; Figure 4). There was an indication of a preponderance of males in the sample but the difference in numbers was not statistically significant. Regarding the difference in diving experience between the two groups, computer divers tend to be more experienced, with a mean of 99 months diving (range 0-480) compared with table divers of 70 months (range 0-504). There appears to be a biphasic distribution in table divers with a peak of 25% of those suffering their DCI with under 12 months of diving experience, but there is also a peak at about 108 months (Figure 5).

When we compared the classical diagnosis of decompression illness (DCS I, DCS II, and AGE) in the DAN database, we found significant differences between DC and TD (Figure 6). The proportion of those with an AGE was significantly higher in TD. This does not prove that table divers in the general population are more likely to suffer AGE than computer divers but suggests some interesting hypotheses. Since DC divers tend to be older and more experienced than TD, they may have fewer rapid ascents and low air situations that can lead to AGE. Also, most dive computers have ascent rate indicators, which may help DC users avoid rapid ascents. The proportion of table divers with DCS I was greater than DC users, but this

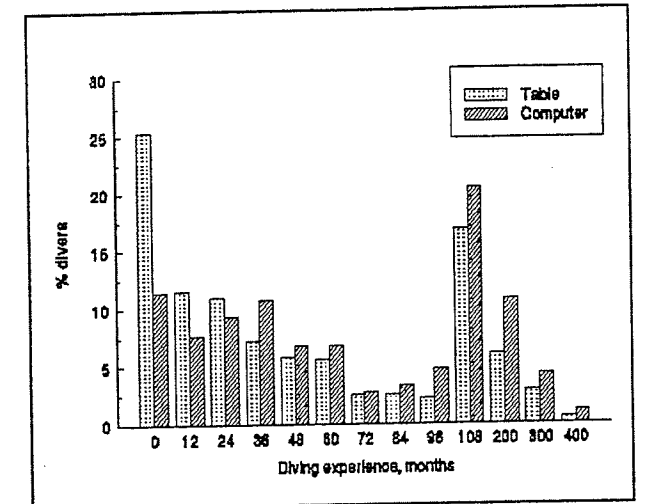

Figure 5. Months of diving experience, by group. Computer divers tend to be older.

was not statistically significant. The proportion of TD with DCS II was also greater than DC but, again, the difference was not significant.

We next looked at the clinical presentation of decompression illness by symptoms. The percentage of divers with pain was significantly higher in computer divers. This was consistent with the greater proportion of DCS I in DC divers. Dizziness seemed more frequent in computer divers but not significantly so. All other neurological symptoms including weakness, paralysis, and bladder dysfunction appeared to

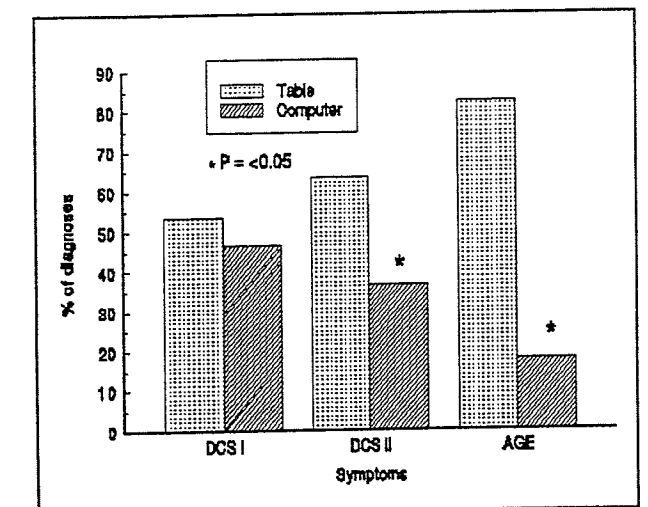

Figure 6. Distribution of classical DCI symptoms, by group. AGE - arterial gas embolism; DCS I = pain and itching only; DCS II = neurological symptoms.

be more common in table divers but the differences were not significant (Figure 7).

When we consider the delay to decompression treatment, the majority of divers in the DAN database received decompression treatments 24 hours or more after their diving incident. This is in contradistinction to the military experience when the delay to recompression is usually well under 6 hours; in commercial diving the treatment usually begins within minutes of the appearance of symptoms. There was, however, an early peak of divers treated at less than 6 hours, about 20-25% in both DC and TD. Computer divers were no more likely to receive early recompression treatment (Figure 8). There was also no difference in the onset times of the first symptom, the majority of which were less than 1 hour (Figure 9).

The response to treatment and the severity of the incident were indicated by the presence or absence of residual neurological symptoms when assessed post therapy by a follow-up telephone call to the divers by DAN staff. Neurological residuals were present in 29% of TD but in only 25.3% of DC. There were significantly more long-term residuals in TD (7.1%) than in DC (3.2%) when the divers were contacted at three months. This most likely reflects the severity of the initial disease.

Conclusions

Recreational scuba divers who use dive computers and suffer decompression illness and are entered in the DAN database are older and more experienced, and dive deeper and make more repetitive dives than divers who use

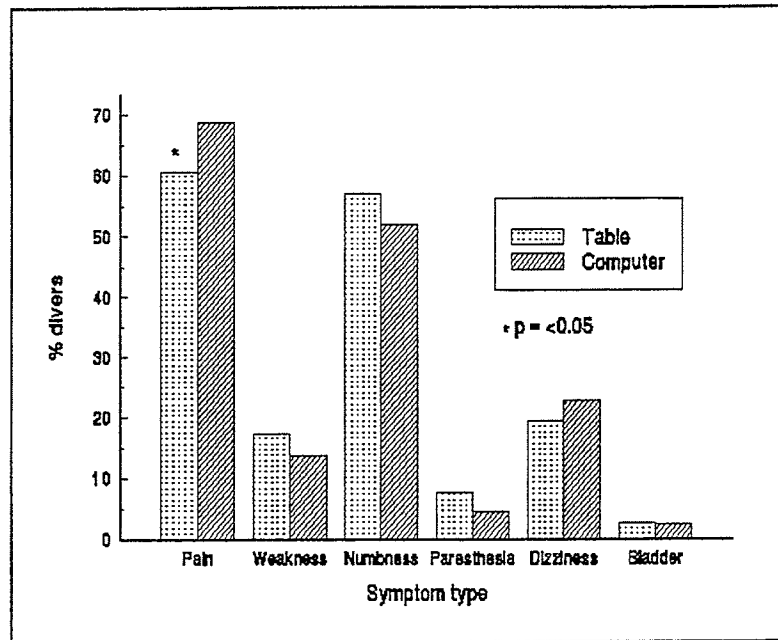

Figure 7. Distribution of some common symptoms by group; from left pain, weakness, numbness, paresthesia, dizziness, bladder. Only the greater occurrence of pain in DC divers is statistically significant. This is consistent with the lower occurrence of neurological symptoms with DCS.

tables. Reported decompression illness in DC users may have fewer serious symptoms, but most differences between DC and TD are not significant. The DAN database does not record

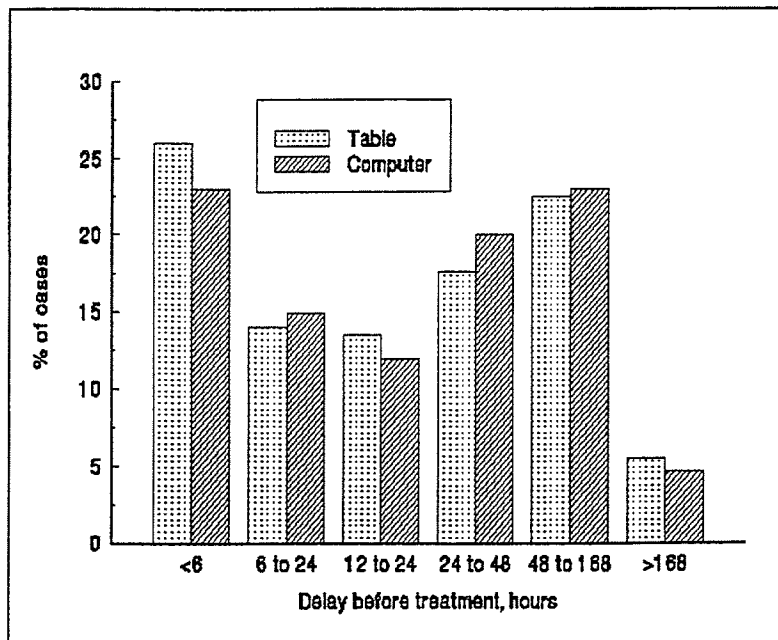

Figure 8. Delay before recompression treatment. There were no differences in the delay pattern between table and DC divers.

sufficient detail to make it possible to address fully the differences in DCI risk between DC and TD in repetitive diving.

An answer to this question will require complete depth time profiles, accurate symptom descriptions and onset times, data about safe dives as well as dives with DCI, and standardized data collection and analysis procedures. DAN is developing such a project with the ultimate goal of collecting data on one million dives. This project will be 1-2 years in preparation before data collection begins and at least 5 years in data gathering. It will use dive computers to record dive profiles on incident-free dives as well as those resulting in decompression illness. Computer software has been developed for the project and is now undergoing field testing.

Dr. Guy Dear is Assistant Professor of Anesthesia at Duke University Medical Center, Assistant Medical Director of the Divers Alert Network, and Chief of the General Pediatric Anesthesia Operating Room Services; he started at Duke in 1991. He graduated from Cambridge University, and did medical training at St. Georges Hospital Medical School. Interest in diving medicine started with the Cambridge University Underwater Exploration Group. His interests in hyperbaric medicine include cardiorespiratory physiology and clinical work at the FG Hall Laboratory. He is involved with development of projects at DAN including Project Dive Safety, diabetes and diving, neuropsychological testing and dive computers.

Discussion after Dr. Dear

Chairman RW Hamilton: Was the population you analyzed here taken only from divers who reported in to DAN for treatment, or was it from a collection that you got some other way?

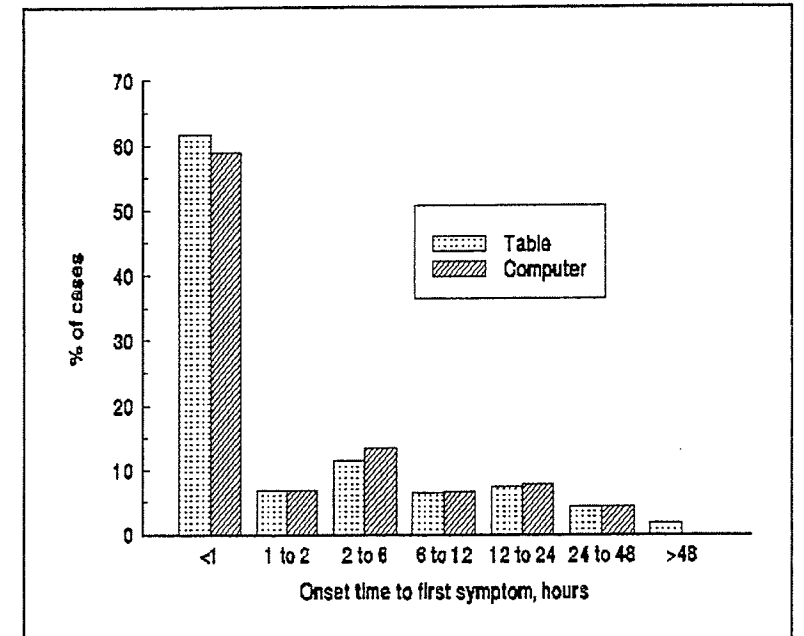

Figure 9. Onset time to first symptom. There were no differences in onset time between table and DC divers.

Dr. Dear: This is from the DAN accident report forms.

Chairman: It seems to me that the decompression sickness aspect of it was about the same for all. But the population showed quite a bit of difference between the computer users and the others.

Dr. Dear: Yes. I can tell you that the symptoms and the type of decompression illness appeared to be very similar, but the population is a little different. Whether that is significant, I am not sure.

Dr. Bill Norfleet: Do you have any information on how well those computers that give you the okay to go flying are doing at that task?

Dr. Dear: We have not done that analysis. We do have the data on which computer was involved with each of these bends cases, but we have not analyzed the computer data. It is certainly true that "symptomatic flying after diving," in other words, somebody who has symptoms who then flies, is likely to result in a serious bend. We have not looked at that particular aspect.

dollars that they spend. Military, scientific, and commercial diving combined are not large enough to create this base and to foster the development of these computers that we are talking about.

Also, I submit that we are not having a great number of terrible bends cases in this industry. Yes, there is a risk in diving, and, yes, we do have cases, but there are not a terrible number of them. It is amazing and extremely valuable that these computers do work, based on theory and procedures that originally were not intended for this use at all.

The development we do in the recreational community is not meaningless, as was suggested this morning. We are creating the base. We are creating the impetus. If there is a desire to have computers, it comes from the recreational community.

What we need are relatively safe limits in a useful tool for multi-level, multi-dives per day, and multi-day diving; that is what it's all about.

Methods

Let us look at some of the information that we were able to acquire. There were 16 DCs (dive computers) available to us in late 1992, on the market at that time. This Workshop review reports the range or scope of the set of computers, but does not attempt to provide a "Consumers Report" of each of them. Computer names are used as examples, but manufacturers, etc., and such details are given in the published review (Hardy and Shuster, 1993). The tests were sponsored by *Rodale's Scuba Diving* and were conducted in the hyperbaric chamber at the Wrigley Marine Science Center on Catalina Island.

We ran 61 controlled dives in the chamber to establish the "conservative versus liberal" position of the set of test computers. Of those 61 dives, we varied some nine seconds in the timing on the dives, and we varied less than a single fsw (foot of sea water) on the control of the depth.

The dive patterns simulated were:

- ☉ A single dive to 60 fsw for the no-stop time.
- ☉ A single dive to 130 fsw for the no-stop time.
- ☉ Three multilevel dives simulating an active day of diving, beginning with a morning dive of 100 fsw and two successively shallower (afternoon and night) dives (Figure 1).

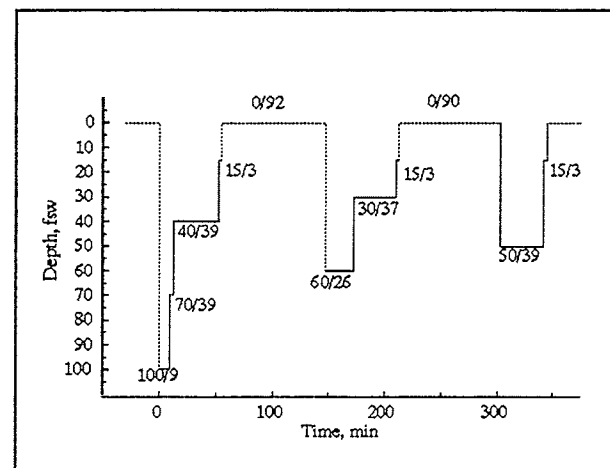

Figure 1. Three multilevel dives in one day. This one is also the first day of a two-day sequence.

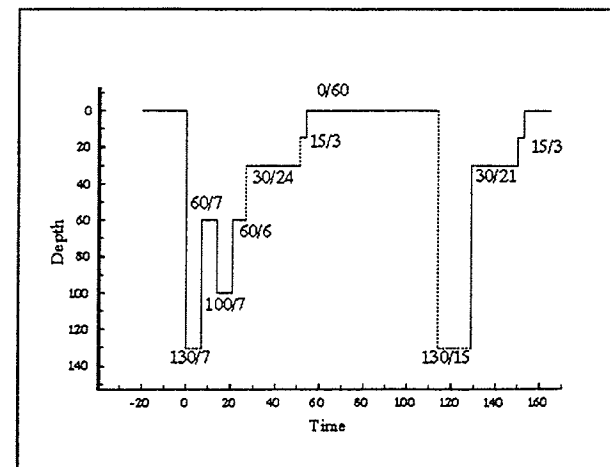

Figure 2. Second day of a 2-day multilevel dive series; first day is shown in Figure 1.

- ☉ Two deep multilevel dives, the first to 130 fsw, as the second day in a 2-day multiday sequence (Figure 2).
- ☉ A single multilevel "sawtooth" dive consisting of bouncing back and forth between 100

fsw/3 min and 60 fsw/6 min 4 times. We kept repeating that pattern over and over again until we stressed the computers into decompression (Figure 3).

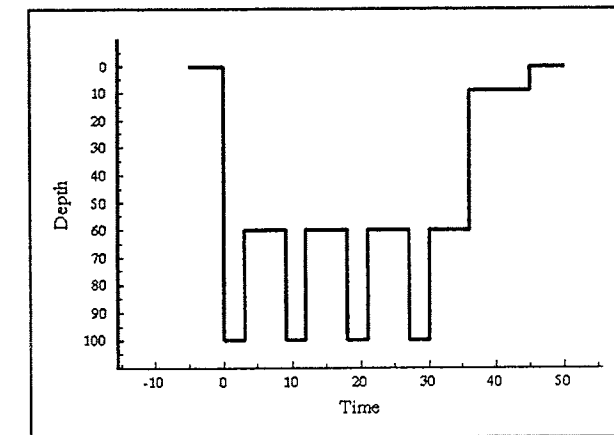

Figure 3. A single sawtooth series. Individual dives are 3 min at 100 fsw separated by 6 min at 60 fsw. A 9-min stop was required at 10 fsw.

- ☉ A yo-yo series of repeated bounce dives to 130 fsw/10 min (Figure 4).

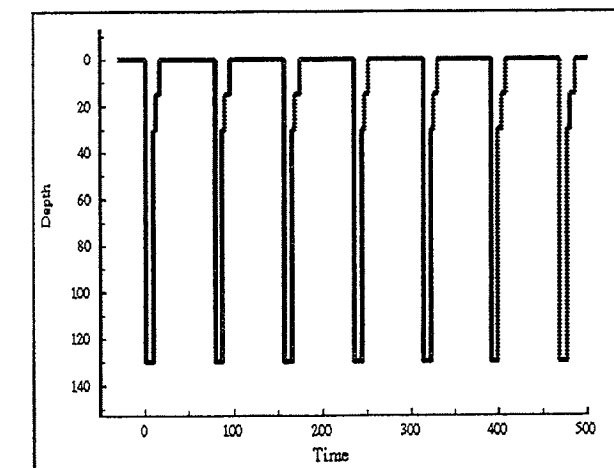

Figure 4. Yo-yo pattern of repetitive bounce dives. These dives are 130 fsw for 10 min with a 5-min stop at 15 fsw and a one-hour surface interval between dives.

The last two sets are patterns of diving that are generally not recommended because they are believed to result in an unacceptably high incidence of DCS; these were done to see how the computers would respond.

Note that the terminology on some of these dive patterns is not too rigid, since there can be a "yo-yo" pattern in a single dive, or multiple, closely-spaced "bounce" dives can form into a yo-yo pattern. A single "bounce" dive is down and back, and usually has a relatively short bottom time.

Other open water tests by divers from neophytes to experts evaluated the durability and ergonomic aspects of the DCs, both in the water and at the surface before and after dives.

Results

Table I shows the results of the tests on a rank basis. As mentioned, the effort in this workshop article is to show the behavior of DCs in general, not to rate individual computers. The stress is believed to get generally more severe toward the right of the table. The groupings show computers that are approximately equal in conservatism for that dive pattern. Note that the allegedly most conservative computer in the dive industry at the time, the Scubapro DC-11, is at the top of the list (most conservative) for the 60 fsw dive. But notice how the DC-11 stays in the very first group until you get to multi-level, then it drops down into a second group, and then on bounce dives it drops still further down, becoming far less conservative.

Consider the street wisdom of the Orca products, the Marathon and the Phoenix. They are allegedly the most liberal products available, but notice that they are not the most liberal on a single 60 fsw dive, and they are in fact even more conservative when that single dive is deeper. For multi-level they become more liberal, and for multi-level over two days, they become even more liberal, and then, on multi-level saw-tooth diving—the so-called yo-yo situation on a single dive—they are liberal, but notice that they then move up to being less liberal on the yo-yo multiple repetitive bounce dives.

The test profiles did not exceed the ascent rate of any computer. We came up at 20 fsw per minute because that was the rate required by the slowest computer in the group. On the

Table I. Computer groupings.

	Single dive to 60 ft	Single dive to 130 ft	One day multilevel	Two days multilevel*	Multilevel sawtooth*	Bounce dives*
More conservative	DC-11 ----- Aladin Pro Aladin Sport Legend Monitor 1 Monitor 2 ----- Computek II Companion Solution ----- Marathon Phoenix	Computek II DC-11 ----- Marathon Phoenix Companion Solution ----- Aladin Pro Aladin Sport Legend Monitor 1 Monitor 2	Aladin Pro Aladin Sport Companion DC-11 Legend Monitor 1 Monitor 2 Solution ----- Omni Computek II Datamax Pro Datamax Sport Marathon Phoenix Source Scan 4	Computek II Datamax Pro Datamax Sport DC-11 Omni Scan 4 Source ----- Aladin Pro Aladin Sport Legend Companion Solution Monitor 1 Monitor 2	Computek II ----- DC-11 ----- Aladin Pro Aladin Sport Legend Monitor 1 Monitor 2 ----- Companion Solution ----- Omni ----- Marathon Phoenix Datamax Pro Source Scan 4	Datamax Pro Datamax Sport Omni Scan 4 Source ----- Computek II ----- Marathon Phoenix DC-11 ----- Companion Solution Aladin Pro Aladin Sport Monitor 1 Monitor 2 Legend
Less conservative	Omni Datamax Pro Datamax Sport Source Scan 4	Omni Datamax Pro Datamax Sport Source Scan 4	Marathon Phoenix Source Scan 4	Marathon Phoenix		

Note: Computers grouped together gave approximately equal results * See dive profiles above

repetitive deep bounce dives, the last column in Table I, we used the current safety practices in the recreational diving field. We did not exceed 130 fsw, the recommended recreational limit, we used a minimum 60 min surface interval, and we also utilized "safety" stops.

For the repetitive bounce dives we also put in a deeper safety stop (30 fsw) in addition to the "regular" one at (15 fsw). Actually, that was a data-gathering point. We were trying to stress these computers to see when they would give up, when they would throw in the towel.

Table II shows results from the multiple 130/10 bounce dives shown in Figure 4. All the computers do fine until Dive Number 3, and then five of the computers go into violation. All these are manufactured by the same manufacturer for these various companies; all have an override in them, something special in their program, to cause them to say, "Whoa, that's it, you've violated me, I can't proceed."

Then we continued on until Dive Number 6, and another computer goes into violation. On Dive Number 7, our allegedly most conservative and most liberal computers all go into violation

Table II. Repetitive deep bounce dive tests.

Dive	Total Decomp Stops		Computer status
	Actual	USN	
1	8	0	All normal function
2	8	4	All normal function
3	8	21	Five computers go into violation: Omni, Data Max Pro, Data Max Sport, Source, and Scan 4
4	8	35	All others normal function
5	8	61	All others normal function
6	8	61	One more goes into violation: Computek II
7	8	61	Three more go into violation: Marathon, Phoenix, and DC-11
8	8	61	Seven computers still in normal function: Aladin Pro, Aladin Sport, Legend, Companion, Solution, Monitor 1, and Monitor 2

Totals: 64 min actual compared with 304 min required by USN equals 240 min of "missed" decompression time.

at the same time, and, finally, on Dive Number 8, we are now into an endless loop, both with the Navy tables and with the computers; some

have not yet gone into violation. The Navy tables tell us we need 61 minutes of decompression every time. It just keeps going over and over and over again, and the remaining computers tell us we can just keep going over and over again.

For the record, these trials were exhausting to the chamber crew. You can imagine the full chamber with 16 computers running simultaneously. These dives were all manned, by the way, but we rotated the crew so no one tender was exposed all the way across, and also the tenders decompressed on oxygen. The computers just did their normal thing. None of the tenders got the bends, and we did man all the dives.

Discussion

The message here is that what is more conservative and what is more liberal all depends on the dive pattern, the profiles the computers have to deal with. There is no one absolute here on any of these computers.

So, not being a doctor and representing the view of the diving industry, my question is, what is correct here and what have we learned? Are the tables correct? Are the computers correct? Are our procedures correct? Or is the medical view of all this correct? These are important questions, and I think this is where we need to take a really serious look at these kinds of things.

But a serious look has to be from the point of view of success, of making these things work better and still do their job.

Recommendations

Table III shows suggested improvements we came up with after these hundreds of exposures we did in testing these 16 computers.

Item Number 3, providing an ascent rate indicator is extremely important because you cannot manage the new slower ascent rates as a recreational diver without something to guide you.

Table III. Suggested dive computer improvements.

1. Have a plastic prompt card.
2. Prepare good instructions and a diver training video.
3. Provide an ascent rate indicator.
4. Use ascent rate of 60 fsw per minute deeper than 60 fsw and 30 fsw per minute in shallower water.
5. Provide a graphic display of nitrogen saturation.
6. Have only one step needed to activate the computer.
7. Retain for logging the last several full time-pressure profiles [preferably with downloading to a PC.]
8. Use long life batteries that can be changed by the user or the dive store.
9. Calculate and provide time to fly.
10. Do not require computer to be dry between dives.
11. Provide both no-stop and air limits on computers with pressure gauges.
12. Provide method for user to put in a conservatism factor, such as a caution zone, altitude change, or graph, to permit backing off.
13. Do not alternate screen use when in the water.
14. Put in a two-dive restriction on deep bounce (square) dives until more is known about this.
15. If a depth or decompression stop violation occurs, warn the diver but do not "shut out" or stop computing decompression! Diver should be allowed to make a correction and continue the decompression, followed by a definitive "penalty" on the next dive. [Do not allow a correction unless it is continuous. Then either use a warning or a short partial lock out.]
16. Make computer displays as easy to read and as self-evident as possible.

Number 5, calls for a graphic display. We need to make what a DC does a little more understandable to the general diving public. To these people who watch television, who don't have college degrees, who don't pay attention to all these scientific things, we need to give them a way to understand what's going on, and a graphic display certainly goes a long way toward doing that.

Number 9, says a DC should calculate and provide time to fly. It is ludicrous for the recreational community—which travels tremendously—to be told that all dives are equal. These computers can do sophisticated computations under water. They should be able to do so on the surface, also, for time to fly. It may need more research, but you can't tell me that a dive to 15 feet for 30 minutes is the same thing as a week of wall diving. There has to be a difference in the time to fly.

Number 12, provide a method for the user to put in a safety or "J" factor, such as a caution zone or the like. This is extremely important as we look at the various factors that influence these things, many of which have been mentioned today, such as the workload, the temperature, and so on.

But we cannot tell how a computer is going to be used. We do have to rely somewhat on people's intelligent use of them and try as best we can to have them used intelligently.

Item 16 deserves extra emphasis also. To make the DC as easy to read and self-evident as possible is important. This means "user friendly" in the computer world, and it also appreciates all of us now in our twilight years who need to be able to see these instruments under water.

[Number 7, logging the last several profiles for possible downloading, is a favorite of the Editor and other physiologists at the Workshop. All dive computers should have profile recorders that can record the time-pressure profile of several hours of diving, and allow the resulting data to be downloaded to a computer. This is an important factor in personal dive planning and management, an extremely beneficial factor in research on diving and decompression, and as an extra bit of diagnostic data that can be valuable in the event a diver needs treatment for decompression sickness.]

I hope that the manufacturers and the medical community will look at all these suggestions, particularly the ones just mentioned.

A list of safety suggestions is given in Table IV.

Table IV. Safety recommendations for use of dive computers.

1. When computers disagree, use the most conservative one.
2. Make deepest dive first.
3. Make deepest part of the dive first.
4. Allow 12 or 24 hours before flying, or follow the computer.
5. Avoid dives that require stage decompression.
6. Avoid dives deeper than 100 fsw, particularly repetitive dives.
7. Avoid sawtooth and yo-yo diving.
8. Wait 24 hours before starting computer diving or after a problem with a computer.
9. Do not share computers.
10. Plan the dive and dive the plan.
11. Make surface intervals as long as possible, at least more than one hour.
12. Do not exceed the computer's rate of ascent.
13. Take safety stops at 10 to 15 feet.
14. Read the computer manual, and get training if in doubt about anything.
15. Avoid diving near the limits of the computer.
16. Have a back-up method for decompression.

Also, I think we need to change our thinking about the concept of "decompression diving." This might be heresy in the recreational community (and I am of course one of the strongest proponents of this community, as you see). That is, let us admit to the fact that we do decompression diving all the time. We decompress during all ascents, and all dives involve **some** decompression. The safety stop that we now all use is a form of decompression, and the computers are giving us decompression information all the time. The concept that recreational divers do not do "decompression diving" is a fallacious idea now past its time. Let's just admit to it and start a new generation of more careful, safe diving, where we make our diving as effective as possible, broaden our horizons, but just admit that we have to decompress and do so properly.

What we need is relative safety, not absolute safety (otherwise we could neither dive nor drive or fly to the dive site), and DCs are useful devices that will make this diving possible.

Reference

Hardy J, Shuster B. 1993 Feb. Computer age. *Rodale's Scuba Diving* 50-57, 102-107.

Jon Hardy is a diving professional specializing for more than 30 years in recreational diving as an instructor and operator, but who periodically operates also in serious commercial diving. He is a former Naval officer, a consultant, an occasional expert witness, and a prolific writer to the recreational diving community.

Discussion after Mr. Hardy

Dr. Fred Bove (Temple University, Philadelphia): Jon, I appreciate your review; we are all looking forward to seeing your next report. So many questions get raised about which computer to use and so on, it now sounds to me like we can in fact match computers to individual preferences for the way they dive, at least to some extent. But your last few statements kind of imply that we ought to make the computer "diver proof" and have it do everything for the diver. I am more or less convinced that we will not ever be able to make something that will deal with all variations of human behavior. We ought to make sure that the training organizations make very, very strong commitments to training in the use of dive computers and/or tables, because we see so much of the community abusing tables or not knowing how to use them or not knowing how to use computers. It seems to me that no matter what we do, we will not make these things diver proof. We have to **train**, and I would make a plea that in addition to trying to make the DCs more user friendly, that we continue to intensify the training about the use of tables and computers, because otherwise we will never begin to solve the problem of getting rid of decompression sickness.

Mr. Jon Hardy: Thank you for bringing that out. I completely agree with what you've said here. I have said for years that what we need is intelligent use. Human beings have to control these devices, but if we make them as effective as possible and as readable as possible, then the human being can make better decisions. I really appreciate that comment on intelligent

use of the device. The human has to control the device, not the device control the human.

Dr. Peter Bennett (DAN, Durham, NC): A very nice presentation, Jon; very logical. I am beginning to feel, as we heard from Bill Hamilton this morning, that computer narcosis is prevailing. Let us not forget that what we are dealing with is an empirical relationship of gas uptake and elimination, going back to poor old Haldane, who has much to answer for.

As we have heard, we now have—whatever it is—12 compartments, or 16. Who cares? I have a great suspicion after 40 years in this business that maybe compartment half times do not have all that much to do with decompression, and that we may be on the wrong game. All we do is keep adding a bit more time, another half time, and we get a longer table, and everybody jumps up and down and says, "gosh, look at that, we've solved decompression." No, you haven't. I can do that without a mathematical computer. I can do it by adding five minutes, 10 minutes, and 20 minutes and so on.

We must not lose sight of the fact that what we really need is a lot more basic research, and understanding about what is going on in decompression and then we will be able to get some correct answers. Until then, let us not forget that it is **empirical**. I would like to see that word stamped on every computer, that this is an empirical method for decompressing you and has no great validity.

Chairman Hamilton: Peter, that is why it does have validity, because it is **empirical**; it is based on **experience**. Empirical is a bad word only to the pure theorist.

Dr. Claude A. Harvey (Navy Diving & Salvage Training Center, Panama City, FL): I would like to add one quick word to what Peter Bennett said. On the matter of flying after diving, it is indeed quite simple to make calculations. It is quite another thing to have a data base, so the calculations will mean something; there is indeed a great deal of work to be done. A lot of our algorithms that seem to work for diving once we crunch the parameters enough are not predicting altitude exposure

very well. Most of the papers I have seen use bubble growth and shrinkage based on perfusion of the tissues (and a lot of other things) and are still having trouble giving adequate altitude projections. Further, airplanes do not all fly at the same altitude. So, that is a very complex problem that is going to take a bit of time to solve. One interim approach is to use some rather conservative overall blanket rules.

Mr. Hardy: Yes. We keep coming back to the data base. Yes, we need it, and that has to come out of the recreational community, because that is the only place where we have enough divers doing enough dives.

Update 1995

Since the time between when this Workshop was held and its publication there has been some progress in the development of recreational dive computers. Jon Hardy and the Editor have provided some information to help bring things up to date.

Since the Workshop in 1993 we have seen developments in dive computers that to a certain extent address the issues raised at the Workshop. Unfortunately there is still no ideal computer, but the available options give the diver many choices that in most cases can be matched to the individual style of diving, and there are computers for a range of different budgets. These advances plus an additional series of tests have been documented in 3 articles (Hardy et al, 1994 Jul; 1994 Aug; 1994 Sep).

Air integration

Probably the biggest innovation is the incorporation of air supply information into the DC's. At least 7 top of the line computers include this feature, and some are "hoseless" in that they use a magnetic or sonar signal to transmit the air pressure information to the display unit. Since air supply is really the big concern for scuba divers, these units should add a great deal of safety to the dive.

Enriched air or "nitrox" computers

Since it is now quite fashionable to use oxygen-enriched air or "nitrox" for many types of recreational diving, some of the computer manufacturers have risen to the occasion with computers designed to be used with these oxygen-nitrogen mixes. Some allow

the use of one or more fixed mixes, and others allow the mixture composition to be set. Since diving with enriched air requires divers to be aware of the buildup of oxygen toxicity, these computers also contain algorithms that monitor oxygen exposure.

Downloading and dive analysis

Some dive computers have the ability to download the dive profile data to a personal computer. Some provide rather detailed analytical capability. For example, the Uwatech Air X, the market version of the adaptive computer described by Prof. Bühlmann, shows not only time and depth but also the status of the diver's work load as the dive progresses. We endorse this innovation.

Display

Several new types of display are being tried. Some DCs use color effectively. For example, one allows the diver to simply stay "in the green" without having to worry about numbers. Some have internal lighting which is a big help in diving in low light conditions. Some use sound to warn the diver when limits are reached, including voice as well as beeps. Others are working on heads-up displays that put an image of the data in the diver's mask.

Gas loading display

We seem to be going full circle. The first recreational DC, the ORCA Edge, had a display of the gas loadings in the various "tissue" compartments used for the computations. The trend now is to go back to some sort of display that reflects the divers gas loading.

Lockout and decompression calculations; time to fly

Many of the newer generation have eliminated the annoying and dangerous aspect of **locking up** when the diver violates a decompression limit. More are also offering calculated (rather than only timed) **flying after diving** information.

References for the Update

- Hardy J, Brumm J, Hodges-Palmer V. 1994 Jul. Chips ahoy. Rodale's Scuba Diving 42-46, 100-101.
 Hardy J, Brumm J, Hodges-Palmer V. 1994 Aug. Number crunchers. Rodale's Scuba Diving 56-60, 91-95.
 Hardy J, Brumm J, Hodges-Palmer V. 1994 Sep. Air time. Rodale's Scuba Diving 86-92, 111.

PRACTICAL USE OF DIVE COMPUTERS IN SPORT DIVING

Bret C. Gilliam
 Ocean Tech, Bath, ME

Gilliam BC. 1995. Practical use of dive computers in sport diving. In: Hamilton RW, ed. The effectiveness of dive computers in repetitive diving. UHMS Workshop 81(DC)6-1-94. Kensington, MD: Undersea and Hyperbaric Medical Soc.

The popularity of diver-carried electronic "dive computers" (DCs) capable of calculating multi-level dive exposures has been growing since the mid-1980's. These units employ widely varying decompression models and algorithms and there is no formal infrastructure of sport diver training (other than isolated specialty programs and manufacturer's manuals) to ensure diver competence and familiarity with the DC. Workshops have recommended guidelines for use, and two texts have been published as sources of instructions for reasonable dive practices. Some DCs provide a retrievable record of the diver's activities, including surface intervals and subsequent repetitive exposures. This could enhance the accuracy of documentation in a sport where divers are notorious for poor attention to such details. Surveys comparing decompression illness incidence between computer divers and "table" divers have shown the efficacy of computers in reducing DCI to around .02% if used properly, including extensive repetitive diving. Both DAN and IUF/NAUI plan more extensive data sampling from specific DC profiles. The computer cannot think for the user so common sense and awareness of safe dive planning practices must be assumed by the diver. DCs make it easier to skip conventional dive planning. Computers will calculate, plan, and "allow" deliberately provocative dive exposures if the user chooses. DCs have achieved anywhere from 20-35% market share, with active experienced divers on liveaboard vessels seeing almost 100% usage. Proper implementation of DCs into sport diving programs involves matching a decompression model to the individual diver, prudent observation of progressively deeper to shallower profiles, adherence to programmed ascent rates, allowance of sufficient surface intervals between dives, reasonable daily repetitive exposures (2-3 dives), and following manufacturers' guidelines for maintenance.

Introduction

Any discussion of dive computers should immediately identify the problems associated with current survey methods. What should be of interest to us as medical and diving professionals is not what we *think* divers should be doing, but rather what they are *actually* doing. That is the reality of sport diving and that is the market that most dive computers are aimed at. Do they meet the demands of providing an acceptable risk for exposures they can control?

Let's talk about that. But first a little background.

One of the greatest obstacles that must be overcome by many divers in their acceptance of diving computers is their initial "comfort level" with the concept of multi-level diving theory. This is a foreign and alien concept for many divers whose dive planning has traditionally followed square profile planning paradigms. In fact, a certain "suspension of disbelief" is necessary to grasp the allowed multilevel exposure that deviates so radically from fixed norms such as "60 fsw for 60 minutes," etc. Like many new

evolutions in equipment, dive computers were initially met with skepticism and outright condemnation by some members of the diving community. In retrospect, much of this hostile reception was undeserved. The most vocal critics tended to be the so-called experts who were never fully cognizant of the theory of multilevel diving that was widely applied as far back as the late sixties.

Historical Perspective: Deco "meters"

For those who were already familiar and comfortable with multilevel diving through the use of various analog devices such as the SOS Decompression Meter, the switch to modern electronic computers was less traumatic. In spite of the obvious flaws in the "computational" method of the SOS device, once the field user was able to sort out a practical SOP (standard operating procedure), the units became virtually indispensable and were used with success by thousands of divers for over twenty years.

The SOS Decompression Meter was introduced in 1959 but did not gain widespread U.S. distribution until Scubapro gained import rights in 1963. Although not a "computer" by any stretch of the imagination, this relatively simple device provided the first basis of practical underwater calculation of multilevel diving and became immensely popular with professional photojournalists, film makers, and divers who were tired of being boxed in to the confines of historical "square profile" table plans. Although many simply dismissed the "decom meter" as unvalidated and branded it the "Bend-O-Matic," thousands of divers used it without incident and only grudgingly parted with their well-worn units to make the switch to electronic computers.

Obviously, the old "meter" users were comfortable with multilevel profiling and the transition to modern computers was a natural progression. Some early computer models failed to live up to expectations or suffered from design failures that led to flooding, power failures, etc. These initial problems were almost completely eliminated, and in 1993 today's diver has over two dozen highly accurate and reliable computers to choose from.

The introduction of electronic computers in the early 1980s was initially met with the same skepticism by critics who loudly trumpeted the perils of any device that could possibly allow a dive exposure of "100 feet for an hour and half." As anyone who has used computers in multilevel applications knows, such an exposure is not only attainable and routine, it is also relatively benign since the dive is typified by the initial deep phase and then followed by progressive ascending stays at shallower depths.

So why use a computer? Quite simply, they are more accurate in measuring depth and time, and virtually every model available incorporates a decompression algorithm *more conservative* than the standard U.S. Navy tables. Most divers use computers to gain more time underwater safely since the units are "active" devices that compute theoretical tissue/compartiment inert gas loading and outgassing based upon actual depths and times. This provides an obvious benefit to "square profiles" where the diver's uptake and release are modeled on assuming that the entire dive was spent at the deepest depth for the total dive time.

Electronic dive computers

But even if you have a problem accepting the theory of multilevel diving, then modern computers will give you a safety edge based upon their highly accurate depth measuring sensors and timing devices. Using them solely in this application can provide a safety buffer for the strict table user. Some models are significantly more conservative than the Navy tables. For instance, we can all remember that the U.S. Navy tables allow 60 minutes at 60 feet with no decompression. By comparison, the Dacor Micro Brain Pro Plus computer allows only 44 minutes for the same depth based on its Bühlmann model and program that presumes diving at slight altitude.

The acceptance of diving computers has literally swept through the industry in the nineties. Just a glance around any liveaboard vessel will confirm this, and more and more entry level divers are purchasing computers during or immediately after training. Although any piece of equipment can fail, modern dive computers are

extraordinarily reliable. Additionally, there is some evidence of the reliability of their decompression models. In a study of 77,680 dives by sport divers, we found zero cases of DCS among computer users, who made up over 50% of the data base (Gilliam, 1992).

Recent workshops and symposia have seen respected experts predict such a dominance by computers that diving tables as a primary dive planning protocol may well become obsolete. Although not willing to go on record officially, the majority of professional underwater photographers, resort guides, etc., have already abandoned tables and use computers exclusively.

Tables versus dive computers

Are dive computers the answer to increased diver safety when considered in comparison to diving tables?

Teaching tables

Fundamentally, it's a question of learning retention by students. Decompression tables are a skill learned primarily to pass a test, and whatever brief proficiency is acquired during training is quickly lost. The facts in this area are fairly indisputable. Dr. Kelly Hill sponsored a volunteer survey on divers attempting to solve elementary decompression table problems that showed a failure rate of better than 50% (Hill and Hill, 1989). Even more alarming is that his survey divers included experience levels from basic open water ratings to instructors! So much for long-term retention. Any resort divemaster can confirm the same problems daily.

Compounding the confusion for the student is the myriad variety of tables in use. Some students begin training in one agency system and progress in another. They are then expected to relearn either new tables, modified versions, or altered configurations. In a 1986 trial during cross-examination of a prominent hyperbaric expert witness (who shall mercifully remain nameless), I gave him a set of PADI

tables to work a simple two dive repetitive scenario. He failed three times in his attempt from the witness stand and totally discredited himself with the jury. And this was one of the country's foremost medical experts on diving treatments who worked with tables every day. He was used to the U. S. Navy tables. But switching the format on him was a curve ball he couldn't hit. Why should we expect basic students to do any better?

Unfortunately, I do not think we can completely eliminate the teaching of tables to students unless they clearly indicate that they are each going to purchase a diving computer. Even so, a background in table use is good and is an ideal introduction to computer theory. Computer training should be given the same level of importance, however. Why? Because it is easier and more efficient for divers of all levels to dive with these instruments. Their automatic functions eliminate most of the record keeping responsibility that divers are so sloppy with and it also takes away any mathematical burden in computations. Also, when considered on direct comparison with Navy tables, virtually all computer algorithms are more conservative on normal square dive profiles.

Profile awareness

I can assure you that if you handcuffed 50 entry level divers together and lowered them on a diving stage to a certain depth for a certain time and then brought them up at the same rate, if you were then to ask for their dive profile you would get about 50 different answers. Computers remove a significant amount of human error from the equation. Yeah, sure all things mechanical can fail . . . but you can also get hit by a bus crossing the street on your way to the dive store to buy a new set of tables. Modern dive computers are incredibly reliable and incorporate timing and depth measuring devices that are far more accurate than most other separate instruments. With the refinement of immersion switches over the last two years, a diver does not even have to be smart enough to turn the unit on. (Those with no sense of humor please note that my tongue is firmly in cheek.)

My perspective has always been to use the available technology to make diving safer and easier. Computers meet that criterion. Recent surveys (Gilliam 1992; Halstead 1992) show that anywhere from 57% to 81% of active divers are using computers. On some liveaboard boats it is a rarity to find a conventional table diver at all. Those who continue to deny their validity are probably still griping about power inflated buoyancy compensators, submersible pressure gauges, octopus second stages, and wet suits that aren't black.

The argument that some computers will "allow" a deliberately provocative dive exposure ignores the fact that dive tables will do exactly the same thing if used improperly. A healthy dose of common sense should be brought to the forefront in dive planning no matter what tools the diver uses to calculate his exposures.

Using dive computers

Some basic operating guidelines should be employed by all divers in using any dive computer. This includes noting and following programmed ascent rates; refraining from reverse profile (deeper after shallow) repetitive dives; selection of a model that is appropriate for the user's age, fitness, and planned diving environment; and adherence to the manufacturer's guidelines for maintenance and battery life. In continuous diving situations, it would be prudent to recommend that repetitive dives be limited to no more than 2 to 4 dives a day separated by appropriate intervals of at least 1.5 to 2 hours. But we also need to recognize the reality that active divers, especially in liveaboard situations, will typically conduct five or more dives per day and their incidence rate of DCS is remarkably low (reported at less than .02% in two large data surveys). I also recommended that within the entry level diver market, say those with less than 75 dives, that computers be utilized exclusively within no-stop limits. This is what we recommend for sport divers anyway.

It is good practice for divers to familiarize themselves with the manufacturer's recommendation for computer failure. Each model applies a different "Murphy's Law" procedure; these

are provided in the computer manual. There is a described protocol for at least one computer (ORCA models) so that the diver may re-enter Navy tables. Michael Emmerman authored this suggested procedure, which is perhaps the only viable return-to-tables scenario. Realistically, his method requires a certain applied discipline and record keeping ethic that may be lacking in most divers.

Computers, like any instrument, can fail, but their track record is extremely good in retrospect. As it has been pointed out *ad nauseam* by some critics, it is theoretically possible for a computer to "allow" a potentially hazardous dive profile. However, even a mild grip on reality will suggest that computers be used conservatively much the same as safety buffers have been added to tables (next greater depth or time) for years by divers seeking a cushion. Don't run your computer to the edge (no pun intended) of its decompression model. Proper maintenance and care including battery changes well before they run out are all part of the diver's responsibility. Please, let us not blame the computer when the batteries crap out because you wanted to squeeze an extra few days out of them.

Risk and the denominator

That pretty much constitutes the generic user guidelines that I feel are necessary to provide reasonable risk. Nothing in life is safe. But, as an active sport, diving is apparently far safer than many others. Indeed our risk has been equated with that of bowling. And when was the last time we read of another tragic bowling injury? Do we really have a problem? Arguably not. What works is what works. Taken as a user group there is no significant additional risk for computer divers as compared to table divers. Indeed, since our reporting systems including that of DAN and the University of Rhode Island are only inputting *accidents* and *incidents*, the entire question of accurate analysis is questionable since we do not know how many *uneventful* dives are conducted. To put it another way, we know the numerator in the fraction but have no idea what the denominator is. (*DAN is taking steps to get a denominator. Ed.*)

Practical use of dive computers

Dive computers have a valid role in diving if used correctly and within their model limitations. Two textbooks have been published that address this issue (Shreeves and Lewis, 1993; Loyst, 1992).

Redundancy

I advocate redundant computers per diver if tables are not used. As divers involved in wreck and cave penetration become involved with more extensive bottom times, the potential of pushing the limits of the decompression model becomes greater and increases the attendant risk. Custom tables should then take precedence, with computers primarily used as digital depth/time instruments and their decompression information used in a back-up role (since they do not deal with these dives adequately, especially if special gas mixes are used).

Planning

Computers have increasingly altered traditional dive planning practices since the diver now has an effective means of calculating deviations from a fixed plan while underwater. Table divers are more regimented with a "plan your dive, dive your plan" discipline, but multilevel divers with computers can realistically "plan" their dive as it happens. It is recommended that divers have a working dive plan scenario prior to water entry, but deviation to take advantage of unexpected marine life appearances or dramatic coral formations discovered at deeper depths is reasonable and will not necessarily compromise decompression safety. The computer (and backup) will allow far more flexibility and yet keep track of no-stop or decompression obligations. The diver must, of course, manage her gas supply accordingly. Use computers as the valuable tool they can be, but don't expect any device to think for you.

Reliability of using dive computers

The examples given earlier of extremes of theoretical computer dives that will predictably produce DCS are not necessarily realistic in

practical use. I would like to see a survey of a broad-based diving user group employing computers of exactly the same model and with the ability to download the profile for examination across the entire profile. This will require sampling in a thirty second time interval (rather than the 2.5 or 3 min used by some DCs) to provide for a true depiction of the dive profile. We need appropriate and realistic field surveys with control subjects and continuity of dive computer equipment. Lab tests alone will not be sufficient. If you are going fishing, go where the fish are.

Some critics have suggested that substantially more testing or acquisition of a controlled data base of use is required before unleashing dive computers on an unsuspecting public. The bottom line is simple. Are diving computers performing to a reasonable degree of safety? Yes, for the typical sport diving application. There is a decade of track record with existing units that suggest an incident rate of DCS equal to or less than that of table dives. The technology is here now. Let's use it and effect the modifications necessary as we identify them.

Likewise, let us not hold the manufacturers to an unreasonable standard of testing and/or built-in "safety factors." As Paul Heinmiller, Vice President of ORCA, has noted, "We gave up trying to make our products foolproof. The fools are simply too ingenious."

References

- Divers Alert Network. DAN 1992 report on diving accidents and fatalities. Durham, NC: Divers Alert Network. (See also prior reports)
- Gilliam BC. 1992. Evaluation of decompression sickness incidence in multiday repetitive diving for 77,680 sport dives. In: Lang MA, Vann RD, eds. Proceedings of the American Academy of Underwater Sciences Repetitive Diving Workshop. AAUSDSP-RDW-02-92. Costa Mesa, CA: American Academy of Underwater Sciences.
- Gilliam BC, Von Maier R. 1992. Deep diving: An advanced guide to physiology, procedures and systems. La Mesa, CA: Watersport Publishing.
- Halstead B. 1992 Sep/Oct. How do divers dive? A survey and opinion in Sources 4(5):. Montclair, CA: National Association of Underwater Instructors.

Hill RK, Hill MA. 1989 Sep. How well do they do it: A survey of sport divers' ability to work decompression problems. Bitterman N, Lincoln R, eds. Proceedings XVth Meeting of the European Undersea Biomedical Society. Haifa, Israel: Israeli Naval Hyperbaric Institute.

Lang MA, Hamilton RW, eds. 1989. Proceedings of the American Academy of Underwater Sciences Dive Computer Workshop. USCSG-TR-01-89. Costa Mesa, CA: American Academy of Underwater Sciences.

Loyst K. 1992. Dive computers: A consumer's guide to history, theory & performance. La Mesa, CA: Watersport Publishing.

Shreeves KW, Lewis JE. 1993. The recreational divers guide to decompression theory, dive tables and dive computers. 2nd ed. Santa Ana, CA: International PADI, Inc.

Bret Gilliam is the President of Ocean Tech, a diving and marine industry consulting firm. He is a licensed USCG Merchant Marine Master and a submersible and aircraft pilot. He has run chamber training programs and treatments since the 1970's and his company was the first to install chamber facilities on dive ships to treat sport divers in the Caribbean, especially the Ocean Quest, the ship mentioned in the article which did an impressive lot of diving. He is the author of several books on deep diving, mixed gas diving, and accident management. He has served on the Board of Directors of National Association of Underwater Instructors, and has served with and organized training organizations for diving with special gas mixtures.

Discussion after Mr. Gilliam

Dr. Peter B. Bennett (DAN, Durham, NC): I have been interested for a long time in why the liveboards don't seem to have problems with decompression illness, at anything like the level of offshore divers or the boats coming out of various resorts. We looked at some of the profiles and began to understand what was going on. They were all doing pretty well; they dive five or six dives a day. They were doing their deep dives first, and then they become shallower and shallower. By the evening or certainly late in the day they were running into very shallow dives, very long dives. I mean in a sense they are doing a "throughout-the-day" decompression. They just don't get into the

problem, compared with the people on a day boat that are doing two or three dives; they work on a computer with the dives relatively closely packed because the boat wants to get back in. So, they have an interval at surface of one hour or less; if the guide really wants to get back faster she cuts it to 40 minutes. So, they get into some problems.

But I think it is very important for us to understand that it is the pure mechanics of it that makes it better, and the computers are not really being tested, as Carl Edmonds would say under these circumstances.

Mr. Gilliam: In some liveboard situations that is true. In fact, in the ship situation we had, as my full report denotes, we had extremely aggressive profiles going on; in many cases we had reverse diving profiles, that we did not condone but in fact they were done. In my opinion, based upon that population we had out there—across a range of seven to 72 years old and with everything under the sun in the way of experience from entry-level divers to very experienced divers—there were some amazingly aggressive profiles demonstrated.

In fact, it was of great surprise to us that we did not see more people get bent in that 80,000 dive population. In fact, we only had seven identifiable and treatable cases of DCS, although we did have some spontaneous relief on other divers with oxygen treatment.

But your comments are certainly very telling, and they do apply within that particular segment. But there are extremes of application out there that seem to be working within the models of these computers. They are not largely reported because people don't want to admit to something that would be outside the peer approval; that is part of the problem, too. We have to remove the denial so we can get to the heart and the truth of what's really going on.

Dr. E. Cuauhtemoc Sanchez (MIEMSS, Baltimore). It seems to me that in sport diving we are training less and relying more on technical instruments. Many of the diving accidents and DCS cases are related to poor dive planning or poor diving training. We cannot rely entirely on

instruments for our training, we have to reinforce the training. It is not that the tables are not working well, it is that our training in tables is not good. We cannot relax in our training and rely on instruments.

Diving is like car driving. Before we had seat belts we had a lot of casualties in car accidents, and we started to use seat belts, and soon we realized that seat belts were not enough, because if you go faster than 40 mph you will still hit the dashboard; so now we have airbags. Now we see that decompression tables and computers are not enough to avoid all the casualties, so we need to get to airbags now in this diving industry.

Dr. Max Weinmann (Harper Hospital, Detroit, MI): In an Australian study we conducted, of our first 100 fortunate recipients of decompression sickness, 35% were within tables and had no identifiable etiology for DCS (Weinmann et al, 1991). The divers who got DCS used both tables and dive computers. Those that used dive computers were fairly dogmatic and utilized the devices as if they had been handed down from Mt. Sinai and, and that with fervent zeal.

After reviewing our cases of DCS we made recommendations that divers not enter into "saturation" diving practices, such as performed on the liveboards and as are recommended by half the diving magazines in the United States and around the world, who are touting unlimited diving.

The magazine *Undercurrent* heralded the lifting of the Queensland limit of three dives per day virtually with the fervor of getting rid of a Fascist rule. Now, in the setting of that, concerning the finding that 35% of divers with DCS did not have an identifiable etiology, it is of profound concern that instruments are being introduced which are creating computer literate but table illiterate divers, who, when the devices fail (and they do fail) are totally incapable of making appropriate adjustments. They are diving four, five, six times a day, and they feel that they have a license, since the computer tells them it is okay, to embark upon much more aggressive dive profiles and thus put themselves at risk.

Now, your comment that we do not see decompression sickness, is meaningless, to be quite blunt, because the majority of divers attribute muscle aches and pains to over-aggressive exertion. The most disconcerting finding on examination is subtle neurocognitive deficits that are often missed. So I think we are under-diagnosing decompression sickness. Divers are presenting late, if at all, and it is a profound worry that the computers are being used so freely.

Mr. Gilliam: Let me comment briefly. You obviously have not read my report, because in fact we had such an extensive orientation to symptom reporting that I was over-burdened with evaluating muscular arthralgia, if you will. In many cases I was called at 0100 or 0200 because somebody who simply had not exercised in the year prior to their diving vacation had lifted their dive bag, and now all of a sudden their shoulder hurts.

Although I probably ran an average of 10 "tests of pressure" a week, in most cases DCS was quite clearly eliminated because in fact they were not pressure-related injuries, the divers were not bent. We had a very well-trained staff out there, including a staff doctor, three DMTs and myself as the chamber supervisor and the overall program director. We encouraged complete and honest reporting. We also threw a safety net in there for everybody, because not only did we recommend that people get DAN insurance prior to coming on board the ship, we also had an internal insurance program; for \$10 for the week, all medical care was free. We did not put any financial obstacle in anybody's way to stop them from reporting.

Now, all the comments I think you have addressed so far are related to training and to attitudes about it, but they are not related to the device itself.

I'm a ship captain by trade. I did not throw away my sextant when they invented global positioning systems. Okay? The DC is just another tool that makes doing some things easier, and as I said earlier, you have to bring a healthy dose of common sense to the table. We are not ever going to be able to solve that by

making a device smarter or more reliable. I think the reliability of the devices now is very, very good. At one point it was not, but it is now. Certainly, divers are going to dive on tables and stay within the limits, and they are going to get bent. I have treated many of those in my career. How I have yet to treat anyone who was diving within the limits of a properly-used computer and presented themselves for treatment. That is just a fact of life. I have about 200,000 dives of those people that I had a chance to monitor within a completely closed population, cooped up on a ship where they could not get away from me. If they were going to have a problem, believe me, I was going to know about it. So, that is the best answer I can give you, that you're really talking about an attitude that goes back to training. Don't blame the computer. In aviation, you know, we call that pilot error.

Dr. Alfred A. Bove (Temple University, Philadelphia): I have a little bit of uneasiness about the index of identifying decompression prob-

lems as only the immediate problem. I have concerns that these long multiple exposures may relate to long-term effects, particularly osteonecrosis, which we generally have not seen in the sport diving community. I wonder if anybody shares that. When you look at the literature on osteonecrosis, it is clearly related to gas loading on longer and deeper dives. We may not know until 10 years from now that this in fact may be producing "long-term decompression sickness." I just want to raise the question; I do not know the answer. I wonder if anybody else has similar concerns.

Chairman: Dr. Edmonds mentioned that. One of the first symptoms of decompression sickness in recreational divers is denial.

Reference

Weinmann M, Tuxen D, Scheinkestel, Millar I. 1991 Jul/Sep. Decompression illnesses. 18 months experience at the Alfred Hospital Hyperbaric Service. SPUMS J 21(3):135-142.

VALIDATION WITH DATA SUPPLEMENTING OR IN LIEU OF CHAMBER TESTING

Russell E. Peterson

Peterson Technical Service, West Chester, PA

Peterson RE. 1995. Validation with data supplementing or in lieu of chamber testing. In: Hamilton RW, ed. The effectiveness of dive computers in repetitive diving. UHMS Workshop 81(DC)6-1-94. Kensington, MD: Undersea and Hyperbaric Medical Soc.

Criticism of recreational dive computers suggests that some of these devices are being sold without having been submitted to formal testing. Without discussing the validity of this complaint, it is pertinent to describe a relatively new mechanism of ethically meeting some testing requirements with a minimal need to actually expose subjects in a pressure chamber. The Workshop on Validation of Decompression Tables issued by the Undersea and Hyperbaric Medical Society (UHMS 74(VAL)1-1-88, 1989) provides guidelines on, among other things, using past experience and field exposures as part of the validation process. The Workshop's efforts were directed primarily toward commercial and institutional diving, but there are useful lessons that can be applied to dive computers. The Workshop recognized that the developing organization clearly has the responsibility for decisions about the quality of decompression, and suggested a mechanism for making the decisions requiring judgement. This could be through a board or group—within the organization but perhaps including outside expertise—charged with that responsibility and having the competence to do it. This could be called a Decompression Decision Board (DDB). The Workshop felt that "interpolative" past experience could be used for new procedures within the tested limits of the experience, and if its applicability could be documented. Advanced ideas which, extrapolations of available experience, require appropriate formal testing. Whatever the validation process, initial field implementation—a provisional stage of operational evaluation—should be with special care, medical backup, monitoring, documentation, and feedback. The DDB would judge when the procedures or DC are fully operational. While the DDB would not be responsible to any higher authority, if questioned its actions would have to stand the scrutiny of its peers. Ongoing feedback and analysis of routine field use is strongly encouraged.

While it would be desirable to test all aspects of decompression procedures to a high degree of confidence in order to ensure a low probability of decompression sickness (DCS), such testing is generally impractical. Chamber dives are relatively expensive and time consuming, and it takes a large number of dives. For example, to establish a 1% incidence of DCS with 95% confidence, over 300 man dives without a single occurrence of DCS would have to be done. If one case of DCS occurred, a total of 478 man-dives would have to be done to establish the same statistical validity. These are very large

numbers of man-dives, and it is not realistic to expect that any procedure or any set of procedures would be given such extensive testing. Thus, alternative approaches to decompression procedure validation are important. Some aspects of such alternatives are discussed here.

In some circumstances, validation can be based on general decompression principles. If a procedure in practical use is modified in a clearly conservative manner, a strong case can be made for no test dives being required to put the revised procedure into operational use.

An example of this approach was given by Dr. Bill Shane several years ago. An air saturation decompression schedule was in routine use for NOAA seabed habitat operations at depths to 50 fsw on St. Croix, USVI. Eventually, however, several cases of DCS occurred, and Dr. Shane decided to try to improve the schedule. His solution was to add two 20-minute sessions of oxygen breathing early in the decompression.

It is highly unlikely that any decompression expert would argue that the modification made by Dr. Shane was not a conservative change. The oxygen exposure that had been introduced was inconsequential from the standpoint of oxygen toxicity and the only impact on decompression outcome could be a positive one. In actual fact, the simple modification made a dramatic difference. Not only was DCS incidence reduced, but fatigue, which had been a common occurrence in the divers post-decompression, was also eliminated. Prior to the decompression modification, that fatigue had been attributed to the general stress of the missions rather than to decompression stress.

To examine some of the problems related to validating decompression procedures, a workshop was held by the Undersea and Hyperbaric Medical Society in 1987. This was sponsored by NOAA's Undersea Research Program, and the meeting was attended by individuals from the US and abroad with a variety of perspectives on decompression. Some had done basic research; others had computed tables. There were also physicians with expertise in diving medicine and physiology and the treatment of decompression sickness; safety officers and operations managers from commercial diving companies, scientific diving programs and military diving commands; a defense attorney with experience in the litigation of diving-related cases. As The Reverend Edward Lanphier was in attendance, even the clergy was represented.

One question that was very basic to this workshop was what a valid decompression procedure is from a legal standpoint. In the opinion of Mr. James R. Sutterfield, the attorney, a valid procedure is one that is deemed to be acceptable by a group of experts in decompression,

such as the one assembled at that workshop (Peterson, 1989). This is an extremely important point because it forms the basis of authority upon which the recommendation of the workshop stands. It also is a critical and implicit feature of the approach that was recommended by the workshop.

Figure 1 depicts the full scope of the approach to decompression development, testing and improvement, over the course of operational use, as agreed by the Validation Workshop (Hamilton and Schreiner, 1989). It includes the development of procedures based on new technology as well as modifications, either small or large, to already-existing procedures. The basic elements of this approach are as follows.

New procedures can be based on experience (e.g., analysis of a data base) or totally original concepts. After derivation of useful procedures (e.g., decompression tables or an algorithm for a dive computer), testing, usually in a chamber, is required to ensure that use of these new procedures is not going to result in catastrophic or uncontrollable failure.

Once a point of adequate confidence is reached through chamber trials, the use of new procedures can be moved to the field on a provisional basis. This means that those who are dealing with the procedures are aware that they are relatively new and not extensively tested, and that everything is in a proper state of readiness at the dive site to deal with a decompression problem, should it occur. Of course, decompression problems in diving must always be anticipated, but with procedures in a provisional phase, particular alertness is called for.

During a provisional phase of field use, it may be found that the new procedures work less well in practice than they did during the chamber test phase. In such circumstances, improvements will probably be called for. So long as the modifications are clearly interpolative, or of a nature that a group of experts would consider to be conservative (i.e., undoubtedly reducing the risk of DCS), an iterative loop of provisional field use and further modification could be continued without additional chamber testing

until a final form of the procedures had been validated for general use in operational diving.

The problems that occur during initial provisional use, however, may be so great that it is deemed necessary to make major modifications to the algorithm or model used for procedures derivation. In such cases it would be necessary to go through a chamber test phase again.

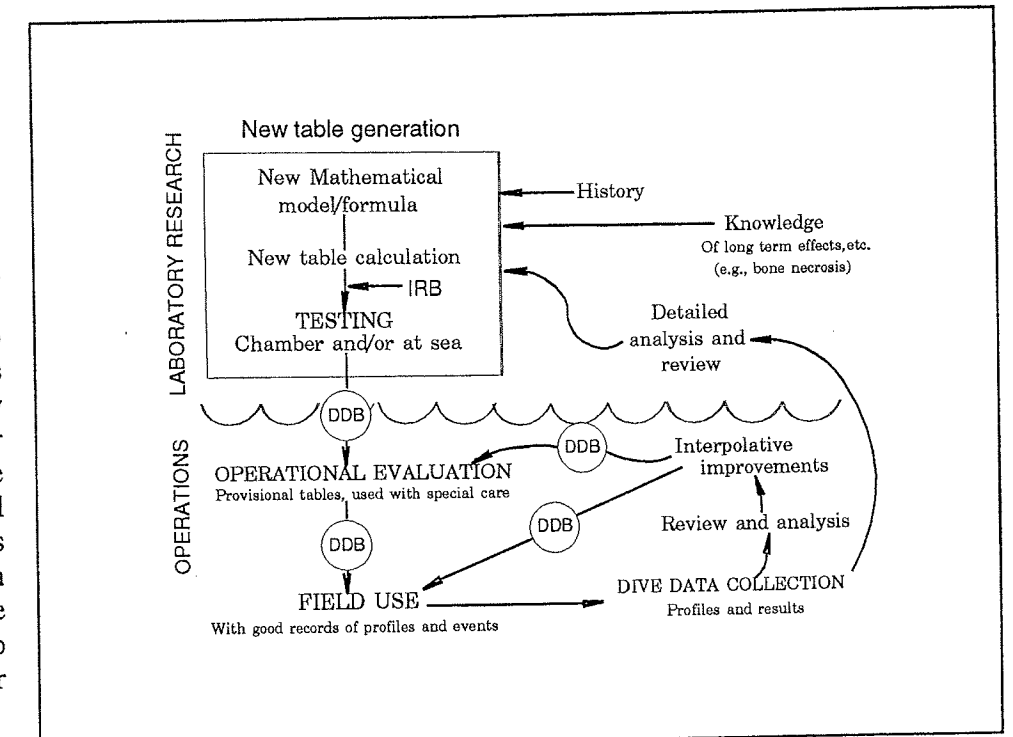

Figure 1. Flow diagram from Validation Workshop.

In Figure 1, the entity shown to be responsible for decisions relating to the testing and validation of decompression procedures is the DDB. (This was originally called the "decompression monitoring board" but is now the "decompression decision board," DDB on the figure). This might be one person or a group of people who are members of the organization conducting the trials or who have been retained by that organization as part of their development team. Presumably it will include at least one expert in decompression technology. It is not an external oversight board, so the name "decompression decision board" is preferred over the earlier one, which has been found to be misleading.

As indicated above, the authority of an internal decompression monitoring board to make decisions is based on the premise that a group of experts would consider what was done to be reasonable and responsible. Practically speaking, this is an equivalent situation to the publication of a scientific paper in a refereed journal. The research is done, the results are documented, and this documentation is submitted for peer review. If other experts consider that the research has been well done and properly presented, it gets published. With

respect to decompression validation, though there is no formal review process of the decisions of the decompression monitoring board, if their actions were questioned, then they would be subject to review by a qualified group of experts.

Thus, an internal decision process regarding decompression validation is not a "license to print money." What is done cannot simply be expedient or cost-effective. If, for instance, the number of trials were grossly inadequate, a group of experts reviewing the development and testing program would not find that it had been properly done.

Therefore, this approach to decompression testing and validation is not a way to "cut corners." It is simply a way of making such activities practical so that decompression technology can be progressed as rapidly as possible in a constructive manner. After all, if improvement of decompression procedures is too difficult, it is the divers using deficient procedures who will be adversely affected. The decompression decision board must keep in mind at all time, however, that if their judgement is challenged

their actions will be judged by other decompression experts, perhaps in a court of law.

Another aspect of this validation process is that if development is not being started from scratch, but is on the basis of substantial experience that can be modified in a conservative way to produce a different set of procedures, then it may be that such procedures could be initially used on a provisional basis in the field. As indicated above, though, decisions of this type would have to be able to stand the scrutiny of other decompression experts. With accurate records of a provisional evaluation phase, preferably including collection of pressure-time-gas profiles, then this approach could provide adequate documentation for the validation of decompression procedures made available for routine field use.

One other point that is important in this scheme is the question of interpolative development or improvement. This means that developments or modifications are made within a domain of relevant experience and are not extrapolations outside the domain of experience. And "domain" does not only refer to the pressure-time limits of the procedures or testing, but also to all the other factors that can affect the decompression outcome. These include the gases used for the dive (e.g., inert composition; oxygen concentration or partial pressure); the repetitive aspects of the dive (e.g., the between-dive interval, the pressure-time relationships from one dive to another, the frequency of dives, their distribution in time, the period over which they are done); the dive conditions (e.g., water temperature, effort levels, swell, current); the diver population (e.g., age, gender, physical condition, diving frequency, recent diving history).

Within a commercial diving sphere or a military diving sphere, there is not a great deal of difficulty because the collective experience usually covers the domain that decompression procedures are going to be applied to. For decompression computers that are being sold over-the-counter to anyone who walks in and buys them,

however, unless their validation covers the whole population of divers and the whole realm of possibilities of dives, then it would be difficult to conclude that the validation has been adequate.

References

- Hamilton RW, Schreiner HR. 1989. Editorial summary: Validation of decompression tables. In: Schreiner HR, Hamilton RW, eds. Validation of decompression tables. UHMS Publication 74-(VAL)1-1-88. Bethesda: Undersea and Hyperbaric Medical Society.
- Peterson RE. 1989. Discussion of research and operational dive classifications. In: Schreiner HR, Hamilton RW, eds. Validation of decompression tables. UHMS Publication 74(VAL)1-1-88. Bethesda: Undersea and Hyperbaric Medical Society.

R.E. Peterson, Ph.D., is a physiologist who works as a consultant in diving and hyperbaric medicine. He trained at the Institute of Environmental Medicine at the University of Pennsylvania under Dr. C.J. Lambertsen. He spent several years in Norway with the Norwegian Underwater Technology Center.

Discussion after Russ Peterson

Dr. Alf O. Brubakk (SINTEF, Trondheim, Norway): There are two points I would like to make. First, when you test these tables it is quite obvious that it is necessary to know what the divers are actually doing. Of course it is a good idea to collect all kinds of profiles, preferably recorded. And by the way, once you have a computer that can record pressure, why not include the capability of continuing to record pressure as you start flying afterwards?

We need a method to describe decompression profiles. It is very difficult if you have a profile that jumps up and down to describe it in meaningful terms related to the problems we are talking about. I doubt that we have that method, but I think it is very necessary to develop.

Secondly, when it comes to testing, we have not—in my opinion—defined properly the end point. The end point now is a set of symptoms being reported or not reported, in many cases not reported, depending on what the divers feel like or whatever. There are many reasons for not reporting, and there are reasons for over-reporting.

So, we need another end point for developing new tables and new procedures for comparing them. Personally I think the only game in town is the possibility of recording the amount of gas produced; that is one way we can compare one procedure to another. That might not be an optimal way, however, since it may be we are not measuring it in the right places; at least that is a starting point. I maintain that it is totally inadequate to test profiles by looking at the clinical symptoms; that is a not a very valid end point.

Dr. Charles E. Lehner (University of Wisconsin, Madison): I note "Knowledge, aspects of bone necrosis," on your slide here. Papers we are presenting at this meeting indicate the association between persistent limb bends and the ultimate outcome of bone necrosis. I think it is incumbent upon those people who model decompression sickness to also take into account the possibility of later outcomes, particularly bone necrosis, which both Carl Edmonds and Fred Bove have mentioned here.

We see the relationship in our sheep experiments between persistent limb bends and the induction of bone necrosis. Transient limb bends, however, tend to be relatively unimportant from the standpoint of ultimate outcome in terms of dysbaric osteonecrosis. However, persistent limb bends are associated with the outcome of sometimes severe bone necrosis, which as you know can lead to permanent disability in the diver.

Dr. Peterson: Implicit in this scheme is that the people making the decisions be aware of current knowledge, so the sorts of things you mentioned are entirely appropriate. If this is the state of the art, then they are required to be aware of it and to account for it in an appropriate way. If they fail to do this, then what they

have done would not be accepted as "reasonable" by experts aware of the state of the art.

Dr. Lehner: We also demonstrated in a short, very limited series of sheep experiments that prompt recompression therapy prevents the development of dysbaric osteonecrosis. Implicit in that is the assumption that one seek clinical recompression therapy if one has so-called "pain only" limb bends. Based on these experiments, perhaps the modifier "pain only" should be dropped from limb bends, especially if it is persistent.

Dr. Carl Edmonds: I think that is the most important thing that has been said today, just that slide (Peterson, Figure 1). It is really very informative.

The real problem with most of the decompression computers is that they have jumped from the mathematical model and the new table calculation—they have skipped these two steps—and gone straight into the field. I think that is where most of the manufacturers have gone wrong. I think this is a wonderful diagram. The only thing I cannot understand is why you did not include animal experiments somewhere, because they will sometimes help you.

Chairman: They come in as "knowledge." Animal experiments are helpful in developing models and new concepts but are of no real value in validating tables for human use.

Dr. Peterson: They would come in over here as part of the basis for developing the model or the theories upon which things are based.

Dr. Edmonds: Right.

Dr. David Elliott (Surrey, UK): Thank you very much, Carl, for your comments about the diagram. I am very pleased because I actually did that diagram, as Bill knows. I in fact wanted to pick up on the last speaker (Gilliam) about bone necrosis. That is obviously absolutely valid within that particular model, but if you look at the reports from the North Sea, in our surveys we have plenty of divers who have had limb bends who do not have bone necrosis, and we have a lot of people with bone

necrosis who have no history of joint pain. So, let us not lose sight of that. I incidentally have just seen one particular collapse in a sports diver that I have been dealing with. The association—and the word was used very quickly, very appropriately—the association is an association.

As far as knowledge on the right was concerned, that was put in because it was decompression table validation, and in fact the

bone necrosis prevalence of the Blackpool tables in compressed air work was meant to enter into the total table generation. So, as far as I'm concerned, therefore, bone necrosis should certainly be considered, but it will take a long, long time to get any answer.

Voice: It says it right there.

Dr. Elliott: I put it there.

THE NMRI PROBABILISTIC DECOMPRESSION MODEL: PERFORMANCE ON REPETITIVE AND MULTI-DAY DIVES

Edward D. Thalmann, Erich C. Parker, Shalini S. Survanshi, Paul K. Weathersby, and P.C. Kelleher*
Naval Medical Research Institute, Bethesda, MD; *Navy Experimental Diving Unit, Panama City, FL

Thalmann ED, Parker EC, Survanshi SS, Weathersby PK, Kelleher PC. 1995. The NMRI Probabilistic Decompression Model: Performance on repetitive and multi-day dives. In: Hamilton RW, ed. The effectiveness of dive computers in repetitive diving. UHMS Workshop 81(DC)6-1-94. Kensington, MD: Undersea and Hyperbaric Medical Soc.

The US Navy has developed a probabilistic decompression model which will form the basis of a new set of air and nitrogen-oxygen breathing mix decompression tables. It is also capable of running in real time, and inclusion of the model in a diver carried decompression computer is being pursued. The model computes decompression profiles to a specified level of risk of decompression sickness (DCS) occurrence and can also be used to compute the risk of DCS for profiles from any source. The model was calibrated to a data base of over 2300 well-documented bounce, repetitive and multi-level dives with both air and nitrogen oxygen breathing mixtures. Time of decompression sickness symptom occurrence information was used to ensure confidence in the time course of risk predictions, allowing computation of profiles based on a specified future risk of DCS, a feature essential for computation of repetitive dive profiles in real time. There were 194 air and 239 nitrogen-oxygen repetitive dives in the data base and the model did a good job of predicting the incidence of decompression sickness on these types of dives (25 observed, 28 predicted). Repetitive dives ranged in depth from 80 fsw to 200 fsw on air, 40 fsw to 150 fsw on nitrogen-oxygen with up to four dives in succession. There were no multi-day scenarios in the data base so predictions of risk for these types of dives are made with less confidence. We feel that the model will give good estimates of DCS risk for any air dive profile (repetitive or multi-level) which can be completed in 24 hrs. The method used to calibrate the model allows future well-documented dives to be included in the data base, allowing new parameter values to be estimated thus improving the predictions in these new areas. The model implements conditional probability in computing decompression schedules. Using conditional probability means that only the future risk of DCS is considered and that at any time the diver is willing to assume the same risk of DCS on future dives as on past dives. Immediately upon surfacing the future risk is maximal and decreases with passing time, eventually reaching zero. If another dive is done before the future risk has reached zero, the remaining risk is carried forward and taken into account in computing the decompression schedule for the second dive. (Supported by NMRDC Work Unit No. 63713N M0099.01C-1011.)

Introduction

The U.S. Navy is in the process of updating its air decompression tables which have been in existence since 1955. These new Navy Air Decompression Tables, which should be available in late 1995, are based on research efforts which have spanned almost 15 years and which were consolidated at the Naval Medical Research Institute (NMRI). The result is a completely new approach to decompression modeling, the NMRI Probabilistic Decompression Model (NMRI Model).

This new approach is based on the assumption that decompression sickness (DCS) following a dive is a random event with a certain probability of occurrence. This means that the number of cases of DCS which may result from a specified number of identical exposures is described by the binomial distribution. Several papers have been published describing the methodology in detail (Weathersby et al, 1984; Weathersby et al, 1985; Weathersby, Survanshi, Homer, 1992; Parker et al, 1992), and I only summarize the important points here before moving on to examine model predictions for multi-day and repetitive dives.

Decompression Model

Full details of the current NMRI Model have been published by Parker et al (Parker et al, 1992) and only a brief outline of the model is presented here. The decompression model we use consists of two parts, gas kinetics and ascent criteria. The gas kinetics portion simply describes gas uptake and elimination during a dive. The decompression model used to compute the current USN Standard Air Decompression Tables (USN Std Air) assumed that gas uptake and elimination could both be described by simple exponential kinetics (Dwyer, 1955; Workman, 1965). These types of kinetics will be called Exponential-Exponential or EE kinetics. We have also explored other types of gas kinetics and have settled on a model which follows exponential kinetics during gas uptake but may switch to linear kinetics during offgassing when a certain threshold level of supersaturation is exceeded, so-called Linear-

Exponential or LE kinetics. Figure 1 illustrates the difference between EE and LE kinetics. The net effect of LE kinetics is to greatly extend the offgassing time compared to exponential decay. The LE kinetics are based on the kinetic portion of a decompression model developed at the Navy Experimental Diving Unit (NEDU) for computation of air or fixed oxygen partial pressure decompression tables for nitrogen or helium inert gases (Thalmann, 1984; 1985a; 1985b).

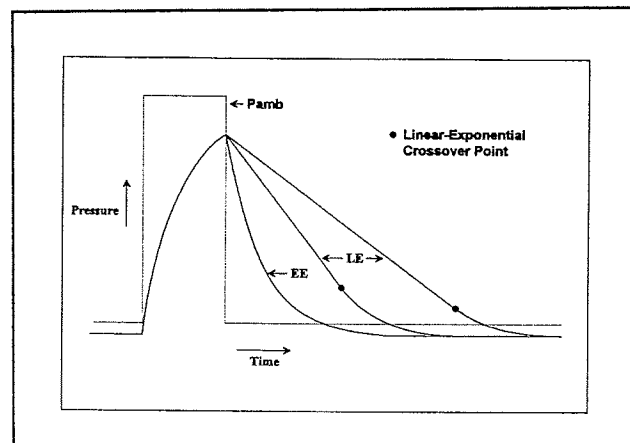

Figure 1. EE and LE kinetics. The pressure profile (P_{amb}) is simple step function. The solid lines are gas tensions in a typical tissue. Gas uptake is exponential in all cases. during offgassing EE kinetics follows an exponential function. LE kinetics are linear until the linear-exponential crossover point is reached at which point an exponential function is followed. The greater the linear-exponential crossover point the steeper the linear slope and the more rapid the offgassing.

The ascent criteria translate the accumulated tissue inert gas tensions into a risk of DCS during or following an ascent. We assume that only nitrogen contributes to the risk of DCS, oxygen is ignored. The original NEDU model on which the LE kinetics was based used deterministic criteria to decide how long decompression should be. Simply put, ascent was allowed until at least one of the tissue inert gas tensions reached a specific depth-dependent maximum value (often called the M-value). At this point a stop was taken of sufficient length to allow all tissue inert gas tensions to decay such that none exceed their particular M-value for the next shallower stop, at which point ascent to that stop was allowed. Decompression tables computed in this way where either "safe" or "un-

safe." If the decompression profile was followed the dive was considered "safe." If the diver ascended too fast and missed some decompression time the dive was unsafe, but there was no way of determining exactly how unsafe. If the diver stayed at a decompression stop longer than necessary he might be considered to be "more safe" but again, there was no way to compute just how much he might have reduced his chance of getting DCS.

The new NMRI approach is a probabilistic one. That is, decompression profiles are either computed to a specified level of risk (i.e. probability that DCS will occur) or a specified dive profile is evaluated by the model to compute the risk for that profile. The basis of our approach lies in defining a risk function, which is the probability that DCS will occur in the next minute or so given that it has not occurred up to now. These types of functions are well known in survival analysis (Kalbfleish and Prentice, 1980; Elandt-Johnson and Johnson, 1980) and their application to decompression models is well described (Weathersby et al, 1984; Weathersby, Survanshi, Homer, 1992; Vann and Thalmann, 1993). In the NMRI Model risk accumulates any time that the tissue inert gas tension exceeds ambient by a specified amount; and its value at any time is related to the supersaturation ratio. Figure 2 shows how risk accumulates for a single tissue as a result of a square dive. During ascent to the first stop risk accumulation begins just before arrival at the first stop at the point where tissue inert gas tension exceeds ambient. With each ascent to a new stop there is a period of supersaturation during which risk accumulates. It is maximum just after ascent then it falls off monotonically. The probability of DCS occurrence during a specific time interval T_1 , T_2 (given that DCS has not occurred before T_1) is found by integrating the risk function r over that period according to the equation:

$$P(DCS) = 1 - e^{-\int_{T_1}^{T_2} r dt} \quad (1)$$

If the integration is carried out from the time risk first begins to accumulate until a very long

time after the dive (say 24 hrs) then the result is the overall expected incidence of DCS for that particular profile. If the integration is carried out over a specified time period, say from surfacing until two hours after surfacing, the result is the probability of DCS occurring during that specific time interval. This latter feature allows us to take the actual time of occurrence of symptoms into account when "calibrating" the model. The time T_2 is the actual time the symptom was diagnosed as DCS and the time T_1 is the last time we are certain

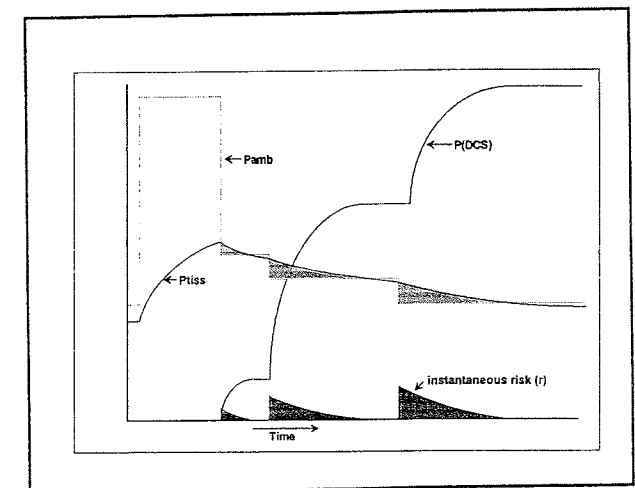

Figure 2. Risk accumulation for a bounce dive. The pressure profile for the dive is shown as P_{amb} and the gas tension in a representative tissue is shown as P_{tiss} . Risk does not accumulate until P_{tiss} exceeds P_{amb} as shown in the cross hatched areas. The instantaneous risk (r) is shown in the lower traces and represents the supersaturation ration at that time (r is constrained to never be less than zero). The time integral of the instantaneous risk is the probability of DCS occurrence and is shown as $P(DCS)$.

that the diver had no symptoms of DCS. T_1 was generally based on T_2 according to a set of rules which are discussed in detail elsewhere (Weathersby, Survanshi, Homer, 1992).

In the current implementation of the NMRI Model a single integration of r is all that is necessary to compute $P(DCS)$, and we call this a Type 1 risk calculation. In another type of risk calculation, r itself is an integral function so two integrations are required to compute $P(DCS)$, we call this a Type 2 risk calculation. The decompression model used for computing the new Navy Air Decompression Tables is one

in which we use LE kinetics combined with a Type 1 risk calculation, resulting in what is referred to as the LE1 decomposition model.

Model selection and "calibration"

The LE1 decomposition model was chosen to compute the new Navy Air Decompression Tables, but one may ask why that particular model? In fact the LE1 model was one of several candidate models, consisting of the possible combinations of the two types of kinetics (EE or LE), combined with either a Type 1 or Type 2 risk calculation with the four possible combinations LE1, EE1, LE2, EE2. The LE1 model was found to be superior based on its ability to predict actual outcomes (DCS or no DCS) of dive profiles contained in a data base (Parker et al, 1992).

The data base consists of USN, Canadian Forces, and Royal Navy dives and is summarized in Table I. The breathing gas was either air or a nitrogen-oxygen mixture. These latter dives were designated as non-air dives and included dives used in developing the MK-15 decomposition tables where the breathing was a constant 0.7 ata PO₂ in N₂ (Thalman, 1984). Single dives were square dives but repetitive dives included multi-level dives as well. For details of the types and sources of the dive profiles in the data base see Weathersby et al (Weathersby, Survanshi, Nishi, 1992).

Most of the dives were done in laboratory hyperbaric chamber complexes as part of man-

Table I. Prediction of DCS occurrence by type of dive (Parker et al, 1992).

Dive Type	Man-Dives	%Total Dives	DCS	Marginal
Single air	876	37%	45	9
Repetitive air	194	8%	14	-
Single non-air	772	32%	29	18
Repetitive non-air	239	10%	11	-
Saturation air	302	13%	32	48
Totals	2383	100%	131	75

ned validation trials of decompression procedures carried out over that last several years, although certain well-documented dives from other sources were also included. All non-saturation dives were immersed, usually in cold water, with divers exercising at depth and resting during decompression. These conditions were assumed to be those where the probability of DCS would be the highest, and it was further assumed that decompression models giving good predictions under those conditions would work for any dive. There were many more profiles considered than those included in the final data base. In order to be included we required that the profile be known to within a 1 fsw accuracy that the breathing gas composition be well known and that other details relevant to decompression stress be reported, such as whether or not subjects were immersed, whether or not exercise was performed, and what the general thermal stress conditions were (i.e., warm or cold water). We also required that experienced medical personnel determine whether or not DCS had occurred after each dive and at what time symptoms occurred. This last point is extremely important, many minor symptoms of DCS will go unreported unless a skillful post dive history is obtained.

There were a number of marginal symptoms which were related to the dive but were of a transient nature and not severe enough to be treated. These types of events are more commonly known as niggles. We wanted to include these in the analysis but did not feel they deserved the same weight as a full-blown case of DCS. After a number of conversations with Navy Diving Medical Officers we decided that 10 cases of niggles would cause about the same concern as a single case of DCS so we counted each niggle as 0.1 DCS. Discussions of the effect of making this assumption have been published (Parker et al, 1992). Our analysis technique used the time of DCS information which was available for all cases of DCS and for 33 of the marginal cases. However, the technique also allowed us to include the 42 marginals where the actual time course was not available (Parker et al, 1992).

In order to choose between candidate decompression models we use the method of maximum likelihood to "fit"¹ the model to the data base. Each candidate model will have several parameters whose values must be determined (tissue half times, thresholds, etc.), and the method of maximum likelihood estimates optimal parameter values which best describe the observed outcomes of DCS in the data base according to that particular model (Weathersby et al, 1984; Weathersby, Survanshi, Homer et al, 1992; Parker et al, 1992). Once the optimal parameter values are obtained for each model then statistical procedures are used to determine which particular optimized model best describes the data. The LE1 model was shown to be superior to the other models based on these considerations. This does not mean that the LE1 model is the absolute best model; there could be another model we did not test (in existence or yet to be formulated) which does a better job, and we are still looking. The LE1 model is just the best one we have tried to date.

How well did the LE1 model do in describing the data? Tables II, III, and IV summarize the fit by comparing the actual number of observed cases of DCS to that predicted by the decompression model. In Table II dives in the data base are broken down by the type of dive showing the number of DCS cases observed and the confidence limits for the number of cases of DCS predicted by the NMRI Model. Confidence limits are not shown in Tables III and IV, only the number of predicted cases. When we look at time of symptom occurrence, Table III, the model did a reasonable job except for an underprediction for very late occurring symptoms. When we look at the dive profiles in which the model is used to categorize them by risk level, Table IV, the number of observed and predicted cases are close with the biggest discrepancy found for dives in the 5—7.5% and 7.5—10% range.

¹ "Fit" in this case means that a set of optimal parameter values was computed such that the model gave the best overall prediction of the observed outcomes in the data base. Absolute measures of fit such as determination of least squares residuals were not used.

Table II. Prediction of DCS occurrence by type of dive (from Parker et al, 1992, with range of predicted cases added).

Dive Type	Observed DCS cases	Predicted DCS cases
Single air	45.9	31-49
Repetitive air	14	10-16
Single non-air	30.8	25-38
Repetitive non-air	11	11-18
Saturation air	36.8	28-52
Totals	138.5	105-173

Each marginal symptom counts as 0.1 case of DCS so the total number of observed cases was 138.5 which was rounded to 139.

In summary, by using the method of maximum likelihood to "fit" the candidate models to a data base of actual dives the LE1 model proved the best of the four models considered. When the LE1 model was used to predict the number of expected cases of DCS, its predictions were reasonably close to the actual number of observed cases.

Table III. Prediction of DCS occurrence by time of symptoms (Parker et al, 1992).

Time category	Observed DCS cases	Predicted DCS cases
Before surfacing	26.5	30.4
Surfacing to +30 min	12.2	15.2
+30 min to +2 hr	26	27.6
+2 hr to +4 hr	23.3	21.8
+4 hr to +24 hr	20.8	12

Prospective Validation

Although the LE1 decomposition model did well in describing the retrospective data in the data base a manned validation trial was neces-

sary in order to test dives where existing data were lacking or insufficient. These trials were conducted at the NMRI and NEDU experimental diving facilities. The NEDU portion of the trial has been presented (Kelleher et al, 1992). Breathing gas was either air, 0.7 atm PO_2 in N_2 or a combination of the two. All decompressions were calculated in real time by

Table IV. Prediction of DCS occurrence by risk level (Parker et al, 1992).

Risk category	# of dives	Observed DCS cases	Predicted DCS cases
0.0-2.5%	535	13.9	9.8
2.5-5.0%	614	21.9	22.9
5.0-7.5%	643	27.6	39.6
7.5-10.0%	298	31.7	25.4
10.0-21.4%	293	43.4	41.4

the calibrated NMRI model. Profiles consisted of single depth, multiple repetitive dives (decompression and no decompression) and long multiple level dives. In some dives a switch from air to the 0.7 atm PO_2 gas was made during decompression to validate the models ability to predict shorter decompression times breathing a high O_2 . Bounce dives were done as deep as 150 fsw and the multiple level dives had several hour periods in the 20-30 fsw range with several intermittent downward excursions.

The combined NMRI/NEDU trial consisted of over 700 man-dives and the overall agreement between the model predictions and the observed incidence of DCS was good, lending support to the model's ability to compute decompression profiles to a specified level of risk. At the completion of the trial the trial data were combined with the calibration data and an updated set of final model parameter values computed.

Decompression profile calculation

The calibration and validation processes described above were used to determine the

optimal parameter values for the NMRI Model. Once this has been done it is a simple matter to use the decompression model to compute the risk of DCS for any candidate profile. One simply performs the necessary risk calculations and integrations from the beginning of the dive until such time after surfacing that the risk has fallen to zero. The result of this calculation is the overall expected incidence of DCS for that particular profile. In this form the decompression model can be used to compare the risks of DCS for any candidate profiles.

Computing a decompression profile to a specified level of risk is another matter. As shown in Figure 2 the risk of DCS ($P(DCS)$) computed using Equation 1 (Weathersby et al, 1984) increases monotonically to some asymptotic value which does not decrease with time and each time another dive is done the risk of DCS will increase further eventually approaching a value close to 1.0. This means that if enough dives are done it becomes more likely that DCS will have occurred at least once. If a set of decompression tables were computed to a specified level of risk, say 2.0%, what advice can you give the diver for a repetitive dive? If we confine him to a maximum risk of 2.0% for all time he can never dive again; impractical advice. We might expect that after some long period of time at the surface, perhaps a day or so, the diver would be absolutely certain that he would not get DCS from his first dive and would be quite willing to perform the same profile again at the same projected level of risk. What this implies is that the diver is not so much concerned with his lifetime risk but the future risk of DCS occurring as a result of a particular dive.

The $P(DCS)$ trace shown in Figure 2 shows the model prediction for increasing probability of DCS occurrence as the dive progresses. Its final asymptotic value represents the interval probability, that is the probability of DCS which would be expected if a large number of divers performed the specified profile. This of course requires that the entire profile be known in advance, including all planned repetitive dives. Simply put, it means that no dives could have been undertaken for several days before and

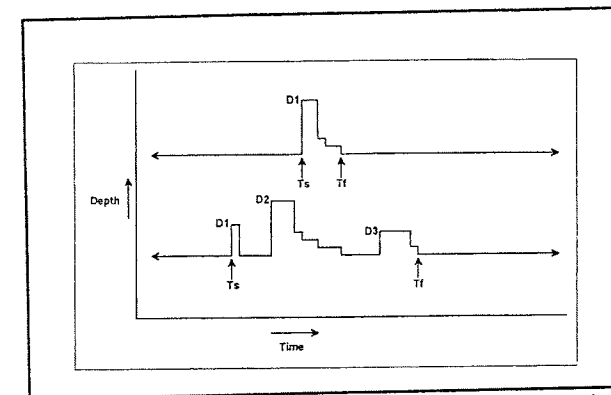

Figure 3. Isolated bounce and repetitive dives. Diver has been at zero depth from time minus infinity to the start of the dive at time T_s . He completes the dive at time T_f and then remains at the surface for an infinitely long time. The only risk of DCS ever incurred at any time is between times T_s and T_f .

after the dive profile under consideration whether it be a single bounce exposure or several repetitive dives; only isolated bounce and repetitive dives could be considered (Figure 3). Since it is unlikely that a diver will know his entire life's dive history and future plans at any given time this method of computing risk is impractical. We initially circumvented the problem by considering that a 24 hr surface interval (36 hrs following saturation dives) is sufficient to consider no risk carryover from a previous decompression where there are long surface intervals between exposures it; is not much help if a diver wants to do another dive with a surface interval of only a few hours.

We were able to get around these problems by including time of DCS information in constructing our model. Including this time of DCS information lets us predict times during a dive when the risk of DCS is particularly high or low (Weathersby, Survanshi, Homer et al, 1992). When only the DCS incidence is used the only portion of the $P(DCS)$ curve we can have confidence in is the asymptote; the way the risk accumulates with time (i.e., the shape of the curve) may not be accurate. By using time of DCS information we now have confidence in both the asymptote and the shape of the $P(DCS)$ curve, allowing us to invoke conditional probability, the probability of DCS occurring at any time in the future given that it has not occurred up to now.

To understand the difference between the interval probability and conditional probability an analogy to a bombing mission is useful. Let us say that before taking off on a particularly dangerous bombing mission a pilot learns that of the last 100 sorties, only 50 planes have returned. Before starting the mission the pilot can only conclude that his chances of being shot down are 50%. This is the interval probability and gives the chance of being shot down at any time during the entire mission. However, the pilot has some additional information as shown in Figure 4. The bottom curve shows where in the mission the planes were shot down and the risk is not uniform. There were three areas in particular where the risk is particularly high, the area of coastal defenses, over the target, and from enemy fighter planes during the return home. During the actual mission the crew gets

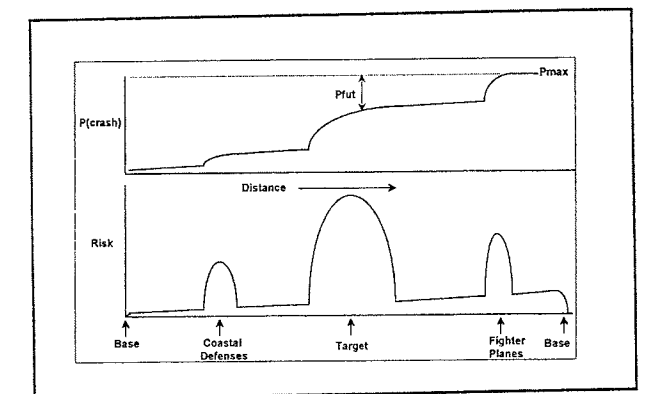

Figure 4. Conditional probability. An example of the risk of crashing during a bombing mission is used. Bottom trace shows the instantaneous risk of crashing during a bombing mission. As soon as the plane takes off from its base the baseline risk increases because of the possibility of a mechanical failure. The risk of crashing increases dramatically as the plane crosses the coastal defenses and falls again as these are passed. The same pattern is repeated twice more, over the target and from an enemy fighter base on the return trip. The cumulative area under the lower trace is shown in the upper trace ($P(\text{crash})$) and represents the probability that a crash had occurred at some time before that point in the mission. It increased from a value of zero before takeoff to a value of P_{max} after landing at the base again. the conditional probability of crashing having survived up to a certain time is the future risk (P_{fut}) and is the difference between P_{max} and the value of ($P(\text{crash})$) at that time. The conditional probability has a value of P_{max} at the start of the mission and decreases to zero at its completion.

through the coastal defenses. The pilot now knows that his chance of returning is now greater than 50% since he has survived after transiting a high risk area. Once he completes his bombing run and begins to return to base he knows his chances of not getting shot down have increased considerably, he now has two thirds of the risk behind him, and when he shakes off the enemy fighters he sees his chance of returning as almost certain, except for a possible mechanical failure as indicated by the slightly upslping baseline.

Like the bomber pilot, as a diver progresses through a decompression and the following surface interval without getting DCS he knows his chances of getting DCS in the future are steadily decreasing. The conditional probability is computed from Equation 1 (Weathersby et al, 1984) with T1 set to now and T2 set to an infinite time after reaching the surface, no previously encountered risk is counted. As time progresses the future risk of DCS gradually approaches. However, if the diver chooses to do another dive before that time some risk from the previous dive is carried over which will be taken into account when computing the next decompression schedule.

Repetitive Dives

While the background information given above is necessary to understand just where the NMRI Model came from, the main purpose of this talk is to see what the NMRI Model predicts in the way of repetitive dives breathing air. To make the comparison we chose to use two methods of determining no-decompression times currently in wide use by the sport diving community for comparison with the NMRI Model. One is the current USN Standard Air Decompression Table repetitive dive procedures (US Navy Diving Manual, 1988) denoted as USN Std Air, and the other the PADI Recreational Dive Planner (Powell et al, 1987). We chose the PADI tables because they are widely used, are familiar to most sports divers, were computed by a slightly different methodology than the current USN air repetitive dive procedures, and have been subjected to some manned validation trials (Rogers, 1988; Powell et al, 1987; Hamilton et al, 1994). At present we have no

Table V. Multiday 60/No-D: 108 min SI x 2 (J>F). Repetitive, multiday No-D dives at 60 fsw. Predictions based on 3 dive/day with 108 min surface intervals, selected to allow Group J to decay to Group F. *Target risk* used for the NMRI first dive was 2.3%.

Repet # ->	No-D Times (min)				P(DCS)
	1	2	3		
NMRI Prob.	Day 1	64	22	21	4.9%
	Day 2	63	21	20	9.7%
	Day 3	63	21	20	14.2%
	Day 4	62	21	20	18.5%
	Day 5	62	21	20	22.5%
USN Std Air	Day 1	60	24	24	5.0%
	Day 2	60	24	24	10.0%
	Day 3	60	24	24	14.8%
	Day 4	60	24	24	19.3%
	Day 5	60	24	24	23.5%
PADI No-D	Day 1	55	41	41	7.0% (6.5%)
	Day 2	55	41	41	14.1% (13.1%)
	Day 3	55	41	41	20.7% (19.3%)
	Day 4	55	41	41	26.7% (25.0%)
	Day 5	55	41	41	32.3% (30.3%)

Values in parenthesis are for dives with 3 min safety stop at 15 fsw

method of comparing the many commercially available decompression computers because without the actual algorithm used by the computer one must run all profiles using a particular computer in real time, an excessively laborious process.

For most of the comparisons we chose 60 fsw repetitive dives as shown in Tables V-XIII. For a 60 min no-decompression time, the diver surfaces from the first 60 fsw dive in USN re-

petitive group J and the new repetitive group at the start of the subsequent dive will depend on the surface interval. The repetitive group at the beginning of the surface interval and the new repetitive group at the end are given in the captions to the tables. Surface intervals were chosen as the shortest which allowed one to be in the specified new repetitive group for the next dive according to the current USN Std Air procedures.

In Table V we look at predictions for a daily series of 3 repetitive dives carried out over a 5 day period. The 108 min surface interval is the shortest allowed according to USN Std Air procedure for just ending up in repetitive group F having surfaced in group J, and was chosen so each day's diving could be completed in a reasonable amount of time, in this case about 6 hours. The no-decompression times computed by the NMRI Model² using a *target risk* of 2.3% are shown in the table as **NMRI Prob.** This *target risk* is the approximate risk level for the USN Std Air no-decompression limits for depths in the 60 fsw to 110 fsw range. For each profile presented here we also note the *total risk* given as the value P(DCS). The *target risk* applies only to each individual exposure, the *total risk* is for all exposures. When computing a no-decompression time the NMRI model ensures that upon reaching the surface the risk of DCS occurring from the time of surfacing to any time in the future, **providing no further diving is done**, does not exceed the *target risk*. The same rule is applied to all subsequent dives. The *total risk* is the combined risk of all the profiles, and the rules of probability state that the risk of DCS for more than one exposure is higher than the individual risk of each single exposure (the more you dive, the more likely you will get DCS at least once). There is no limit to what the *total risk* can be. In Table V the *target risk* for each individual profile is 2.3% but the *total risk* from

²We performed risk calculations using model parameter values current at the time of the presentation. Since data analysis is continuing the final parameter values, when published, may give slightly different results.

Table VI. 60/No-D: 10 min SI x 4. Times allowed for no-stop and repetitive dives at 60 fsw with a 10 min surface interval.

Repet # ->	No-D Times (min)					P(DCS)
	1	2	3	4	5	
NMRI Prob.	64	5	4	4	3	4.4%
USN Std Air	60	0	0	0	0	2.2%
PADI No-D	55	6	6	6	6	4.5%
PADI No-D, with stop 3 min @ 15 fsw.						3.6%

performing 15 such exposures over 5 days is 22.5%.

On day 1, according to the NMRI Model, the first dive has a 64 min bottom time, the second 22 min, and the third 21 min. The surface interval after the third profile of each day is such that the next day's dive begins at almost exactly the same time of day as the previous day's dive. After the first day of diving, no-decompression

Table VII. 60/No-D: 32 min SI x 4. (J>I). Times allowed for 4 repetitive No-D dives with a 32 min surface interval, selected to allow a diver in Group J to decay to Group I.

Repet #	No-D Times (min)					P(DCS)
	1	2	3	4	5	
NMRI Prob.	64	9	8	8	7	5.4%
USN Std Air	60	0	0	0	0	2.2%
PADI No-D	55	20	20	20	20	8.0%
PADI No-D, with stop 3 min @ 15 fsw.						7.1%

times as predicted by the NMRI Model are shortened only a minute or so. The no-decompression times allowed by the USN Std Air procedures have predicted risk levels essentially the same as those for the no-decompression times computed by the NMRI Model. The shortened initial bottom time is combined with

slightly longer times for the repetitive dives but the total bottom times for each day's diving differ by only 5 min at the most.

The PADI Recreational Dive Planner has an initial no-decompression time of 55 min with the diver surfacing in PADI repetitive group W, dropping to group C at the end of the 1 hr 48 min surface interval. According to the PADI procedure each following dive will have a no-decompression time of 41 min. This allows 137 min of total bottom time for each day, some 34—29 min more than allowed by the NMRI Model or current USN Std Air procedure. The PADI procedure recommends a 3 min **safety stop** at 15 fsw any time the diver comes within 3 repetitive groups of a no-decompression limit. In our example the diver begins his repetitive dives in PADI repetitive group C so no safety stop is required but we have nonetheless computed the effect on predicted risk if the safety stop was taken. These risks are shown in parenthesis in Table V. The confidence limits on the predicted risk levels have a relative value 15-20%, making the absolute limits $\pm 5\%$ of the maximum values shown. This means the difference in risk levels resulting from taking the safety stop is not significant according to the NMRI Model. Also, the lower confidence limits for the risk using the PADI procedure slightly overlap the upper limit for the NMRI Model and USN Std Air procedure, indicating that the difference in prediction is statistically significant. But is the difference practically significant?

For an expected incidence of 23% we would expect at least 1 case of DCS but no more than 9 cases of DCS in the first 21 exposures and at least 14 but no more than 32 cases of DCS in the first 100 exposures 95% of the time. At the 32% expected incidence level predicted for the PADI procedure we would expect 3 to 12 cases in the first 21 exposures and 23 to 42 cases in the first 100 exposures 95% of the time. This means that if the NMRI model predictions are accurate, DCS from the type of

Table VIII. 60/No-D: 55 min SI x 4. (J>H). Times allowed for 4 repetitive No-D dives with a 55 min surface interval, during which a diver in repetitive Group J decays to Group H.

Repet # ->	No-D Times (min) [TDT min]					P(DCS)
	1	2	3	4	5	
NMRI Prob.	64	13	12	12	11	6.1%
USN Std Air	60	8	8	8	8	5.1%
PADI No-D	55	28	28	28	28	10.2%
PADI No-D, with stop 3 min @ 15 fsw.						9.3%

multi-day dive shown in Table V should not be uncommon based on the smallest number of expected cases. However, even after 100 man dives the overlap in the expected numbers of cases for risk levels of 23% and 32% is enough that it would be difficult to distinguish between the NMRI and PADI procedure. In this regard both procedures are of similar risk.

Table VI looks at taking the minimum surface intervals for repetitive dives according to USN Std Air procedures. According to these recommendations, with only a 10 min surface interval the next dive has a 0 min no-decompression time. In this case the computed risk for the USN Std Air procedure is the risk from the first 60 min dive only and is 2.2%. The NMRI Model allows a bottom time of 64 min for the

Table IX. 60/No-D: 60 min SI x 4. (J>H). Times allowed for 4 repetitive No-D dives with a 60 min surface interval, during which a diver in repetitive Group J decays to Group H. The increase to 60 min from 55 as in Table VIII has little effect.

Repet # ->	No-D Times (min)					P(DCS)
	1	2	3	4	5	
NMRI Prob. (2.3-5.0%)	64	14	13	13	12	6.3%
USN Std Air	60	8	8	8	8	5.1%
PADI No-D	55	30	30	30	30	10.8%
PADI No-D, with stop 3 min @ 15 fsw.						9.9%

first dive, 5 min on the second dive decreasing to 3 min on the fifth with an accumulated risk comparable to the first day's profile shown in Table V. For the PADI procedure there are two entries. The first No-D, are the no-decompression limits without the 3 min safety stop, and the second is for those same No-D times but with the 3 min safety stop.

Looking back at Table VI, the PADI No-D limits allow only a 55 min no-decompression time for the first dive but the no-decompression times for the following repetitive dives are slightly longer than those computed according to the NMRI Model. The P(DCS), however is only 4.5%, essentially identical to the 4.4% computed if the NMRI Model recommendations are followed. One would expect to see no observable difference in DCS incidence between these two sets of dives. If the PADI **safety stop** is taken during each ascent the P(DCS) drops to 3.6% but this is probably too small a change to have any observable effect.

Table VII shows profiles with a 32 min surface interval, the minimum time to drop from USN repetitive group J to I. The current USN Std Air procedures have a residual nitrogen time of 60 min for the repetitive exposures so only the first dive is no-decompression according to this method. The NMRI Model does allow 9 minutes of no-decompression time decreasing to 7 min on the fifth dive. The maximum no-decompression times allowed by the PADI procedure give generous 20 min bottom times for the second through fifth dives but the P(DCS) increases to 8.0%. Notice that taking the 3 min safety stop reduces the P(DCS) only marginally.

Table VIII shows a 55 min surface interval and the USN Std Air procedure now allows repetitive no-decompression dives. The NMRI model allows longer times with a slight increase in risk. The no-decompression times according to the PADI procedure are now of a high enough risk where the observed DCS incidence may be unacceptable. Again the 3 min safety stop produces only a small decrease in risk.

Table X. 60/No-D: 108 min SI x 4. (J>F). Times allowed for 4 repetitive No-D dives with a 108 min surface interval, during which a diver in repetitive Group J decays to Group F.

Repet # ->	No-D Times (min)					P(DCS)
	1	2	3	4	5	
NMRI Prob.	64	22	21	20	20	7.8%
USN Std Air	60	24	24	24	24	8.5%
PADI No-D	55	41	41	41	41	13.7%
PADI No-D, with stop 3 min @ 15 fsw.						12.9%

The Recreational Dive Planner advises that for 3 or more dives a day where the surfacing PADI repetitive group is W or X that a minimum 60 min surface interval should be taken. Table IX shows that increasing the surface interval from 55 to 60 min has almost no effect on the predicted risk values. The reason for requiring a minimum of 60 min at the surface between dives is presumably due to the assumption that the no-decompression times recommended by the Recreational Dive Planner for shorter surface intervals would lead to a higher incidence of DCS. The NMRI Model predicts the opposite, the risk from following the recommended PADI no-decompression limits for surface intervals shorter than 60 min are of lower risk than remaining at the surface 60 min and then taking the full 30 min no-decompression bottom time on the next dive.

Table XI. 60/No-D: 185 min SI x 4. (J>D). Times allowed for 4 repetitive No-D dives with a 185 min surface interval, during which diver in repetitive Group J decays to Group D.

Repet # ->	No-D Times (min)					P(DCS)
	1	2	3	4	5	
NMRI Prob.	64	33	31	30	30	9.4%
USN Std Air	60	36	36	36	36	10.8%
PADI No-D	55	49	49	49	49	15.0%
PADI No-D, with stop 3 min @ 15 fsw.						14.2%

Dives with the 108 min, and 185 min surface intervals are shown in Tables X and XI. With these surface intervals the USN Std Air procedure has a higher P(DCS) than predicted by the NMRI Model. The PADI No-D times have P(DCS) levels which would be at the lower limit of what we would consider the maximum acceptable risk for even experimental validation dives, 12.0%. Taking the safety stop does not drop them below this level.

The PADI Recreational Dive Planner says that after 351 min a diver who has made a 60 fsw no-decompression dive would be allowed the full 55 min no-decompression limit on each successive dive. This surface interval is shown in Table XII. Comparison of the NMRI Model, USN Std Air procedure and the PADI No-D times shows little difference in computed risk. After 12 hours the USN Std Air procedure would allow a full 60 min no-decompression time for each repetitive dive. Table XIII shows that the reduced 55 min no-decompression time from the PADI Recreational Dive Planner would reduce the DCS risk only by a small amount.

Perspective

The above comparisons may seem laced with caveats and guarded language. There is good reason for this. One is that the predictions made here are just that, predictions. Without observations to back them up there can be little confidence in the absolute risk numbers. We have enough dives in our data base so that we would feel reasonably confident in risk predictions made for two, maybe three exposures during any single 24 hour period but predictions for more than that await verification. To put any stake in predictions made for 5 or 7 dives a day or for multi-day exposures at this time would be premature.

Next we have the uncertainty in the risk predictions themselves. The errors in computing the para-

Table XII. 60/No-D: 351 min SI x 4. (J>B). Times allowed for 4 repetitive No-D dives with a 351 min surface interval, during which a diver in repetitive Group J decays to Group B.

Repet # ->	No-D Times (min)					P(DCS)
	1	2	3	4	5	
NMRI Prob.	64	50	48	48	47	10.7%
USN Std Air	60	49	49	49	49	10.6%
PADI No-D	55	55	55	55	55	12.4%
PADI No-D, with stop 3 min @ 15 fsw.						11.4%

meter values from the available data means that fairly large risk differences are needed before they approach statistical significance. Even if this uncertainty could be decreased the binomial distribution itself tells us that over the course of hundreds of exposures, risk levels would have to differ by almost a factor of two in order to distinguish between two decompression procedures based only on the numbers of observed cases of DCS. From this perspective there is probably no practical difference between any of the three procedures compared in this paper as far as the number of DCS cases which would result over the course of several hundred exposures. Only by making careful observations on several thousand exposures could a distinction be made.

Another point is that the NMRI Model was validated under conditions designed to provoke

Table XIII. 60/No-D: 12 min SI x 4. (J>A). Times allowed for 4 repetitive No-D dives with a 12 min surface interval, during which a diver in repetitive Group J decays to Group A.

Repet # ->	No-D Times (min)					P(DCS)
	1	2	3	4	5	
NMRI Prob. (2.3-5.0%)	64	61	61	61	61	11.0%
USN Std Air	60	60	60	60	60	10.6%
PADI No-D	55	55	55	55	55	9.5%
PADI No-D, with stop 3 min @ 15 fsw.						8.5%

the highest decompression stress likely to be encountered during a dive and that recreational dives would only rarely approach this level of stress. In addition the profiles were followed exactly, to the foot and the minute, which is usually not the case in sport diving. This means that the P(DCS) values computed here can be thought of as upper limits depending on the type of dive performed. This might be one reason that the observed DCS incidence in sport diving might be substantially lower than predicted here. Also, we consider even the mildest pain or discomfort, so long as it persists for more than 15 minutes or so, as DCS. In actual field use many of these very mild symptoms are probably ignored or resolve over the course of a several hour journey to shore, again lowering the reported incidence in actual use.

Given that all three procedures are likely to produce similar numbers of observed cases of DCS the next question is what levels of risk should be avoided. This question has no precise answer at this time, but when designing dive trials we tend to keep the maximum risk computed using the NMRI Model below 12.0% and would not recommend profiles with computed P(DCS) value above 5.0% for routine operational use. That does not mean we would avoid schedules with predicted risks greater than 12.0%. If the Navy mission requirements called for doing the types of multi-day exposures shown in Table V we would test the predictions but take heightened medical precautions (on-scene Medical Officers and recompression facilities) until we had sufficient experience to understand what these predictions mean.

There is one final point to be made in considering the risk predictions made here. There is no distinction made about the severity of symptoms; a mild knee ache has the same weight as a severe CNS. Thus the predicted risk is for any and all symptoms, whether they are just above the threshold of perception or obvious to all. In Navy experimental diving we take great pains to elicit all post dive events, no matter how mild or seemingly inconsequential, so we may record more symptoms than would be found during voluntary reporting following operational or recreational dives.

Conclusion

In summary, the NMRI Probabilistic Decompression Model has been developed and calibrated based on over 2000 past exposures and prospectively validated on over 700 exposures. On these dives the NMRI Model gave a reasonably accurate prediction of risk. For many of the 60 fsw multiple repetitive no-decompression dive profiles considered in Tables V—XIII the predicted risks for no-decompression times as determined by the NMRI Model, USN Std Air repetitive dive procedures and the PADI Recreational Dive Planner are similar. The higher risk predicted for the PADI procedure may not translate into any significant difference in observed cases of DCS compared to the other two procedures because of the large confidence intervals in parameter estimation and the lack of multi-day exposures in the calibration data base.

Given all the caveats mentioned, the real revelation in the new NMRI Model is that its performance can be objectively measured and quantitatively linked to real outcomes on thousands of real dives. Complete with all of the uncertainties we now have a method to evaluate different decompression procedures and to determine what the relative risks of DCS are. As we gain experience and accumulate more data our abilities to predict outcomes will improve and we will be better able to weight the various tradeoffs of decompression time, risk of DCS, and other risks associated with open water diving. Improvements in performance will come as data in areas lacking experience are gathered and as new decompression models are perfected. At every point along the way we will know not only if things are getting better but also how much better.

This work was supported by the Naval Medical Research and Development Command Work Unit 63713N-M0099.01A.1002

The opinions and assertions herein are the private ones of the authors and are not to be construed as official or reflecting the views of the Department of the Navy or the naval service at large.

References

- Dwyer JV. 1955. Calculation of air decompression tables. NEDU Research Report 4-56. Washington: Navy Experimental Diving Unit.
- Elandt-Johnson RC, Johnson NL. 1980. Survival models and data analysis. New York: Wiley.
- Hamilton RW, Rogers RE, Powell MR, Vann RD. 1994. Development and validation of no-stop decompression procedures for recreational diving: The DSAT Recreational Dive Planner. Santa Ana, CA: Diving Science and Technology Corp.
- Kalbfleish JD, Prentice RL. 1980. The statistical analysis of failure time data. New York: Wiley.
- Kelleher PC, Thalmann ED, Survanshi SS, Weathersby PK. 1992 Jun. Verification trial of a probabilistic decompression model. Undersea Biomed Res 19(Suppl):78.
- Parker EC, Survanshi SS, Weathersby PK, Thalmann ED. 1992. Statistically Based Decompression Tables VIII: Linear exponential kinetics. NMRI Technical Report No. 92-73. Bethesda, MD: Naval Medical Research Institute.
- Powell MR, Spencer MP, Rogers RE. 1987. Doppler ultrasound monitoring of gas phase formation following decompression in repetitive dives. In: Richardson D, ed. Recreational dive planning, the next generation: New frontiers in hyperbaric research. Santa Ana, CA: Diving Science and Technology Corp.
- Recreational Dive Planner, Diving Sciences and Technology Corp. Product number 60054. Santa Ana, CA: International PADI, Inc.
- Rogers RE. 1988. Renovating Haldane. Undersea J (3):16-18.
- Thalmann ED. 1984. Phase II testing of decompression algorithms for use in the US Navy Underwater Decompression Computer. NEDU Report 1-84. Panama City, FL: Navy Experimental Diving Unit.
- Thalmann ED. 1985a. Air-N₂O₂ decompression computer algorithm development. NEDU Report 8-85. Panama City, FL: Navy Experimental Diving Unit.
- Thalmann ED. 1985b. Development of a decompression algorithm for constant 0.7 ata oxygen partial pressure in helium diving. NEDU Report 1-85. Panama City, FL: Navy Experimental Diving Unit.
- US Department of the Navy. 1988. US Navy Diving Manual. Volume 1. Air Diving. Revision 2. Washington: Navy Department.
- Vann RD, Thalmann ED. 1993. Decompression physiology and practice. In: Bennett PB, Elliott DH, eds. The physiology and medicine of diving. London: WB Saunders.
- Weathersby PK, Homer LD, Flynn ET. 1984. On the likelihood of decompression sickness. J Appl Physiol 57(3): 815-825.
- Weathersby PK, Survanshi SS, Homer LD, Hart BL, Nishi RY, Flynn ET, Bradley ME. 1985. Statistically Based Decompression Tables I, analysis of standard air dives: 1950-1970. Technical Report No. 85-16. Bethesda, MD: Naval Medical Research Institute.
- Weathersby PK, Survanshi SS, Homer LD, Parker E, Thalmann ED. 1992. Predicting the time of occurrence of decompression sickness. J Appl Physiol 72(4): 1541-1548.
- Weathersby PK, Survanshi SS, Nishi RY, Thalmann ED. 1992. Statistically based decompression tables VII, primary data for testing human N₂O₂ decompression models. Joint Report, NSMRL Report No. 1182 and NMRI Technical Report No. 92-85, Naval Submarine Medical Research Laboratory, Groton, CT; Naval Medical Research Institute, Bethesda, MD.
- Workman RD. 1965. Calculation of decompression schedules for nitrogen-oxygen and helium-oxygen dives. NEDU Research Report 6-65. Washington: Navy Experimental Diving Unit.

Edward D. Thalmann retired from the U.S. Navy Medical Corps as a Captain in January 1995. The studies in this paper were done at the Naval Medical Research Institute where he was assigned from 1987-1995. He also served as the Senior Medical Officer at the Navy Experimental Diving Unit and was on exchange with the Royal Navy Diving Program for two years. He is now an Occupational Medicine Fellow at Duke University Medical Center and is also affiliated with the F.G. Hall Hypo/Hyperbaric Research Laboratory at Duke.

E.C. Parker is an analyst for Automation Counselors Inc. on contract to NMRI. He has a Masters Degree in Geophysics and has been working in decompression Research since 1989.

S.S. Survanshi, the Director of the Scientific Division of Automation Counselors Inc. on contract to NMRI, has a Masters Degree in Biomedical engineering and has been involved in decompression research since 1977.

Captain P.K. Weathersby, MSC, USN is assigned to the Naval Submarine Medical Research Laboratory. He holds a PhD in Chemical

Discussion after Capt. Thalmann.

Engineering and has been working in decompression research since 1977.

LCDR P.C. Kelleher, MC, USN was assigned the Navy Experimental Diving Unit where he was responsible for most of the manned diving done to validate the algorithm. He is currently on exchange with the Royal Navy Diving Program in Alverstoke, England.

Discussion after CAPT Thalmann

Voice: Now that's table development.

Chairman Hamilton: The dive series that you started with as your data base had up to 20% decompression sickness in some of the categories. Were these especially stressful dives? Why was there such a high incidence of DCS?

CAPT. Edward D. Thalmann: A lot of these dives were part of early table developments. Some were used in the development of the initial Kidd-Stubbs model, and some were used in the development of the Mark 15 algorithm. Therefore a lot of them—retrospectively—were in fact very stressful, simply because in a lot of these series nobody knew exactly where to start. The dives did cover a wide spectrum from very safe to very risky dives. When we did our validation dive series, we chose purposely some dives which were allowed by current Navy procedure, but which were risky. In other words, the model before we put the diver in the water said the predicted incidence of bends in this dive is 15%.

However, the table was allowed by current Navy procedure. In fact the model did a pretty good job, because when we did dives that had a predicted incidence of 15%, we ended up with enough decompression sickness that we wanted to go ahead and reduce the risk by increasing decompression time.

Dr. Broom (NMRI, Bethesda): You made a comment that the incremental decompression time had little influence on or small influence on risk, and that the relationship was flat. Why do you think that is or, to put it another way,

does that imply that the factors that contribute to risk at that level are other than time and depth?

Dr. Thalmann: The model that we used only takes into account the depth-time profile and the inert gas tension. It was tested on worst case scenarios. So, it does not include a lot of the other things, but most of the flatness is due to the imprecision in estimating the parameters. The model has to estimate values for 12 parameters, and even with the data base this size, what it reflects is while we are reaching a maximum, it is at the top of a very gently sloping mountain, a very, very shallow mountain. In other words, we do not have enough data to sharpen it up, whether we can ever get enough data to do that, I really cannot say.

The other problem is that, of course, bends is a probabilistic disease. When you have a disease in which on any given day you may get between 0 and 10 hits, say, on the same profile, then you end up with an imprecision. You end up with the kind of imprecision that requires basically tens of thousands of dives before you can compute these parameters to a level that would give you a better relationship between risk and total decompression time.

Mr. Richard Dunford (Virginia Mason Research Center, Seattle): You showed an incremental risk with multi-day diving. I was curious if that was a mathematical projection or did you fit that to actual data?

Dr. Thalmann: I thought I was very clear about that. That's a mathematical projection.

Mr. Paul Heinmiller (ORCA Div. of EIT, Sterling, VA): I have some general comments, not specifically directed to Dr. Thalmann. I see throughout the presentations and the discussion is an interesting trend I would like to work on a little bit. That is the assumption that when recreational divers use dive computers, they are testing the model limits.

Now, when I do recreational diving, that is not my intention. My intention is to see pretty fish,

take pictures, have a good time, spend time under water.

By comparison, those of you who drove here, what percentage of the time that you were driving did you keep your car at the red line? Those of you who came here on the ferry, did you ask the captain to drive the boat at the emergency speed, and those of you who flew, did you ask your airplane pilot to test the edge of the envelope with that airplane on the way up? That was not the purpose of the trip. It was to get here safely, and it is the same thing in the use of dive computers.

Dr. Edmonds and I obviously disagree concerning who is responsible for adding safety factors. When you get through all his noise and smoke, the point he is making is that manufacturers should be responsible for installing safety factors in their computers so that divers cannot possibly do things wrong.

As somebody else said earlier in a few more words, you cannot make things foolproof, the fools are too ingenious.

We believe, for one, that it is not reasonable for us to put in all the safety factors, because we do not know what is going on with the divers. Dr. Bühlmann mentioned that he can measure water temperature, which is true, but then he estimates the body temperature based on the water temperature. He does not know what the diver is wearing for thermal protection. He does not really know what the diver is doing for workload, and he has no concept of what fatigue and dehydration levels are going on during the dive.

So, even if we attempted to cover the other factors, we could not do it. Therefore, the responsibility for that must be on the diver. To that end, we publish a separate book with each computer we sell, so that it is not buried in the manual of operation, which contains a lot of the recommendations that were produced at the AAUS workshop in 1988 (Lang and Hamilton, 1989), a lot of which have been rerecommended by Jon Hardy in his paper.

So, we do think it is the diver's responsibility to add the safety factors.

Chairman Hamilton: Paul, would you tell us in response to one of the computer functions Jon Hardy asked for—the display of the gas loadings—would you explain why Orca has chosen to drop those? They were in the original Edge, but you do not use them any more, do you?

Mr. Heinmiller: That is not quite true. In 1987, the original company, Orca Industries came out with a Skinny-Dipper dive computer, and that did not have any tissue-loading bars on it. Neither did any other dive computer produced in 1987, not the Suunto, not the Micro-brain; nobody had a gas loading bar, other than the Edge, in 1987.

The Marathon (descendant of the Skinny Dipper) is still available today, and it still does not have a tissue bar, but the Phoenix, which is our top-of-the-line computer, (originally designed as a Delphi, 1989), does have a gas-loading bar graded to 100% in 10% increments. We mention in the manual that the effective use of that bar, just as mentioned earlier, is to pick your safety factor. That is, either not to see that bar go beyond the point, or you can review all compartments on the safety stop at 10 feet and use the safety stop to delay ascent until the bar returns to where you wish it to be.

So, we believe in tissue bars. We have in fact a patent on tissue bars because we think it is important, and we intend to put them on all future computers, along with dive profile recorders. I am sure you will not see a new Orca computer without a dive profile recorder inside it.

Chairman Hamilton: Good. I am really glad to hear that.

I would like to ask Dr. Thalmann one more question. What is the accessibility of the algorithm you described? The Navy has made an offer to dive computer manufacturers to include it in their computer, and then come back to the Navy with a dive computer that has it in it. Is this going to be published, or what is going to happen to the algorithm?

Dr. Thalmann: The components of the model will all eventually be published. The actual algorithm, the living, breathing, running algorithm, will be copyrighted, and, therefore if somebody wants access to the actual algorithm, in and of itself for commercial purposes, then they will have to get copyright licenses. The real-time algorithm has been filed for a patent application. So, the same thing would apply there. However, there is sufficient information available that somebody that wanted to spend the time and energy could in fact put one of these things together from scratch. We do not know how long it would take.

The Navy's intent is to make this as widely available as possible. It currently has sent out the software to run the algorithm to eight dive computer manufacturers. We are awaiting their response to see if they are interested in putting this in their computer, and based on that response, the Navy will then decide how it will proceed in order to get a computer constructed to meet its specifications.

Chairman Hamilton: I want to thank the speakers very much. I think we were all extremely pleased with the presentations here today.

Reference

Lang MA, Hamilton RW, eds. 1989 Jan. Proceedings of the American Academy of Underwater Sciences Dive Computer Workshop. USCSG-TR-01-89. Costa Mesa, CA: American Academy of Underwater Sciences.

[Editor's note: This analysis shows only a small benefit from the 3 min safety stop. Lest this be considered an excuse to abandon the safety stop, divers should be aware that this stop has a range of benefits over and above the change in P(DCS). It forces buoyancy control and a more controlled ascent, which among other things helps prevent pulmonary barotrauma, which can lead to arterial gas embolism. The safety stop is still either required or highly recommended.]