

AD-A018 474

PROCEEDINGS OF THE UNDERSEA MEDICAL SOCIETY WORKSHOP (7TH)  
ON MEDICAL ASPECTS OF SMALL SUBMERSIBLE OPERATIONS HELD  
AT SUBMARINE DEVELOPMENT GROUP 1, SAN DIEGO, CALIFORNIA  
ON 19-20 NOVEMBER 1974

D. A. Hall, et al

Undersea Medical Society

Prepared for:

Office of Naval Research

1975

DISTRIBUTED BY:

**NTIS**

National Technical Information Service  
U. S. DEPARTMENT OF COMMERCE

356088

Report Number WS: 7-1-75

ADA018474



**THE SEVENTH UNDERSEA  
MEDICAL SOCIETY WORKSHOP**

***MEDICAL ASPECTS OF  
SMALL SUBMERSIBLE  
OPERATIONS***



**SUBMARINE DEVELOPMENT GROUP ONE**

**19 - 20 NOVEMBER 1974**

**Workshop Chairman: Captain Paul G. Linaweaver MC USN**

**Workshop Coordinator: Lieutenant Commander David A. Hall MSC USN**

**Edited by: D. A. Hall and P. G. Linaweaver**

**UNDERSEA MEDICAL SOCIETY, INC.**

9650 Rockville Pike

Bethesda, Maryland 20014

(301) 530-9225

Reproduced by  
**NATIONAL TECHNICAL  
INFORMATION SERVICE**  
U.S. Department of Commerce  
Springfield, VA. 22151

DDC  
DPC  
A

Medical Aspects of Small Submersible  
Operations

This workshop was supported by the Office of Naval Research  
(Contract N00014-74-C-0319) with funds provided by the Naval Bureau of  
Medicine and Surgery.

Reproduction in whole or in part is permitted for any purpose of the  
U. S. Government.

The opinions, conclusions, and recommendations contained in this  
report are not to be construed as official or necessarily reflecting the  
views of the Navy Department or the Naval Service at large.



# THE SEVENTH UNDERSEA MEDICAL SOCIETY WORKSHOP

## Medical Aspects of Small Submersible

### Operations

#### Table of Contents

Session I	Background Information	
	A. The Future for Submersibles	I- 1
	B. Limitations of Small Submersibles	I-12
	C. Life Support Systems	I-18
	D. Diving Support for Manned Submersibles	I-33
	E. Self Help, Rescue and Recovery	I-36
	F. Proposal for an International Inventory of Undersea Equipment for Use in Response to Undersea Emergencies	I-42
	Summary of Discussion	I-50
	Conclusions and Recommendations	I-55
Session II	Submersible Incidents	
	A. Analysis of U.S. Submersible Accidents	II- 1
	B. The Sinking and Rescue of PISCES III	II-11
	C. JOHNSON-SEA-LINK Incident	II-18
	Summary of Discussion	II-26
	Conclusions and Recommendations	II-27
Session III	Behavioral Considerations	
	A. Personnel Selection, Medical Qualifications and Training Requirements	III- 1
	B. Human Engineering Evaluation of the SDL I	III- 9
	Summary of Discussion	III-16
	Conclusions and Recommendations	III-18
Session IV	Unique Vehicles	
	A. Diversubs: An Overview	IV- 1
	B. Canadian Forces SDL I	IV-10
	C. J.S. Navy Deep Submergence Rescue Vehicle	IV-12
	D. Swedish Rescue Concept	IV-22
	E. One-Atmosphere Diving Suit	IV-26
	F. Why Manned Vehicles	IV-29
	Summary of Discussion	IV-43
	Conclusions and Recommendations	IV-45

**Session V    Non-U. S. Submersible Program Summaries**

A. The Submersible Program in the United Kingdom	V- 1
B. The Submersible Program in Canada	V- 4
C. The Submersible Program in France	V-23
D. The Submersible Program in Japan	V-28
E. The Submersible Program in the USSR	V-35
Summary of Discussion	V-42
Conclusions and Recommendations	V-43

**Bibliography**

**List of Attendees**

## SESSION I: BACKGROUND INFORMATION

### A. THE FUTURE FOR SUBMERSIBLES: CAPT. DON WALSH, USN.

"The Future for Submersibles," is certainly a topic discussed many times before--often, it seems, with a frequency inversely proportional to the amount of deep submergence operations that are being conducted. There was a very quick increase and subsequent reduction in the number of deep submersibles in the 1960's. During this time these vehicles caught the fancy of both professional and amateur ocean-oriented persons (Terry 1966). The almost spontaneous construction of a wide variety of deep submersibles, principally in the United States (ICO 1965), fed the imaginations of the media and the public as well as those in industry who saw this concept as a major path in the advancement of the exploration of innerspace (Shelton 1972). Mission use and support requirements for most of these early submersibles was not carefully worked out and today few of them survive as functional craft. Some of the blame must go to the otherwise rational companies, many of them large aerospace corporations, which failed to analyze exactly what ocean work their creation could do. But, equally, the blame must go to the professionals in the ocean community who encouraged these investments in ocean technology without knowing how submersibles might be used and supported. This, I believe, accounts for why we continue to ask the question about the future of deep submersibles. From the earliest days of the 1950's, with FNRS-3, SOUCOUPE, and TRIESTE to the present, the future has yet to arrive.

This paper focuses on the history of the deep submersible with its implications for the future. A good subtitle might be "Looking Backwards at the Future."

First it is important to define the use in this paper of the terms "deep submergence," "submersibles," and "vehicles." What constitutes "deep" is a relative value judgment. Generally, we can think of deep submergence as a capability to go significantly deeper in the ocean than with more conventional techniques of diving or with naval submarines. Thus, a 300-ft capability in the early 1930's with a bathysphere would be "deep" since neither diving nor military submarines were regularly getting to that depth in those times. Today 300 feet would seem pretty shallow, and hardly "deep submergence." Submersibles can be thought of as undersea craft, or vehicles, which are not autonomous for more than a few hours at a time as compared to submarines which can remain at sea, fully independent, for weeks at a time. Submersibles generally require a mother ship of some sort to service them between diving operations.

#### Invention and the Past

The history of submersibles is rather brief (Terry 1966). The first practical craft were cable-lowered, pressure-proof cabins of wood or iron that were fitted with windows of transparent material for viewing. It is recorded

that Alexander the Great (356-323 BC) had himself lowered into the sea (probably a few feet) in a cask that was sealed with pitch and fitted with a transparent material for viewing outside. Trusted aides pumped air down from the surface to provide life support. Alexander's description of what he saw--a boy eating an apple, a fish that took several minutes to pass by the window, a dog, etc.--might be regarded as one of the first cases of "rapture of the deep." Leonardo de Vinci, of course, included designs for submersibles in his inventive works which covered about every part of the technical spectrum. Around 1716, Sir Edmund Halley, of Halley's Comet fame, devised a working diving bell for support of divers working at depths of about 65 ft for periods up to 4 hr. The history of submersibles, diving, and submarines remained intertwined until the late 19th Century when separate lines of development began to diverge. The submersible's advancement slowed while military submarines and diving moved rapidly ahead. It was not until the 1930's that deep submergence found its resurgence in the work of Dr. William Beebe and his Bathysphere. In a series of 32 dives in 1930, 1932, and 1934 he reached maximum depths of 1428, 2200, and 3028 ft, respectively. Beebe's excellent book, Half Mile Down, is a fascinating chronicle of both the technical and scientific aspects of this pioneering work (Beebe 1951).

The next major advancement came just prior to World War II when the Swiss physicist Professor Auguste Piccard began to adapt his experience in high altitude ballooning to an underwater analog, the bathyscaph (Piccard 1956). He had closely followed Beebe's work and believed that the lowering of the observation cabin by cable from a surface ship had safety problems and practical depth limitations. Piccard's idea was a submersible that was autonomous from surface support while submerged--an underwater free balloon. He secured support from the Fonds National de Recherche Scientifique (FNRS) of Belgium to construct his "underwater balloon" but, due to the war, it was November 1947 before the bathyscaph FNRS-2 was first lowered into the sea. The first dive was in October 1948, to a depth of 84 ft.

The FNRS-2 proved that Piccard's basic design concepts were sound; however, it was not a very seaworthy craft and after it had made an unmanned test dive to 4550 ft it was decided to rebuild much of its structure before initiating manned ocean dives. The FNRS directed that Piccard work with the French Navy at the Naval Arsenal at Toulon to reconstruct the bathyscaph. The new vehicle, now christened FNRS-3, was launched at Toulon in May 1950. It began a series of dives which ultimately led to the establishment in February 1954 of a world's depth record of 13,700 ft in the Atlantic Ocean off Dakar, French West Africa (now Senegal).

Auguste Piccard did not stay with the French Navy's program for the FNRS-3 beyond 1952. Instead he decided to build an entirely new bathyscaph in Italy, which would reflect the lessons learned in construction and operation of FNRS-2 and FNRS-3. Funding was more difficult since the FNRS was only backing the French Navy program. Piccard pieced together a consortium of companies who were willing to donate goods and services towards the construction of the submersible. The main hull was built at Trieste; the cabin at Terni, Italy; with the final assembly at a shipyard in Castillemare di Stabia, near Naples. Thus, in August 1953, the "Bathyscapho TRIESTE" was



first launched to begin a 10-year diving career that would ultimately take it to the deepest known depth in the world oceans. The U.S. Navy bought TRIESTE and it was assigned to the Navy Electronics Laboratory in San Diego, California for support of the laboratory's ocean science programs. In December 1958 the submersible made its first dive as a U. S. Navy asset.

After some modifications at Repair Facility in San Diego, TRIESTE was sent to Guam in the late summer of 1959 where it conducted Projects Nekton I and Nekton II for the next year. In January 1960, its deepest dive was made to 35,800 ft in the Challenger Deep in the Marianas Trench, the deepest known depth in the world oceans (Piccard and Dietz 1960).

During 1960-63 the submersible operated out of San Diego supporting various ocean research projects for the Navy. In April 1963, the U.S.S. THRESHER (SSN-595) was lost at sea off Boston and the TRIESTE was activated to investigate the wreckage which had been photographed by the Navy research ship USNS MIZAK (T-AGOR-11) using a towed underwater camera platform (Keach 1964).

The THRESHER search was the last campaign for TRIESTE and upon her successful completion of this operation she was returned to San Diego in late 1963 for retirement at the age of 10 years. A U.S. built replacement, the TRIESTE II was launched the following year at San Diego to support a continuation of the Navy's deep ocean science and engineering work. In the intervening years the TRIESTE has undergone several major modifications and today's TRIESTE II bears only a family resemblance to the original.

Elsewhere in the world there was also progress in deep submergence. Jacques Cousteau, an early "bathyscapher" with FNRS-2 and FNRS-3 while he was still in the French Navy, built his underwater saucer, SOUCOUBE SOUS-MARIN, in 1958. This craft had a 1000-ft depth capability and was featured in many of his films and National Geographic Magazine articles of the late 1950's and early 1960's (Cousteau 1960). SOUCOUBE is still serviceable and has served as a model for later saucer designs such as the Westinghouse DEEPSTAR 4000 and the French CYANA. The U. S. Navy used the SOUCOUBE at the Navy Electronics Laboratory for an extensive series of dives in the coastal waters of Southern California and Baja California in the mid-1960's (1964-1968).

The French Navy retired the FNRS-3 in 1959 and began construction of a new bathyscaph which would incorporate their experiences in operating and maintaining the earlier submersible. The new craft, the Bathyscaph ARCHIMEDE, was launched at Toulon in 1964 and was placed into operation by a special French Navy group assembled for this purpose. In the past 10 years ARCHIMEDE has operated in major trench systems in the Atlantic and Pacific oceans, as well as the deepest points of the Mediterranean. The greatest depth achieved has been 34,500 ft in the Kurile Trench near Japan.

Credit for the construction of the first U.S. built submersible goes to the American Submarine Company which launched their SPORTSMAN 300 vehicle in 1961. This class of two man craft had a 300-ft depth limit (Terry 1965).

By 1965, over 27 research submersibles were either in service or under construction throughout the world (ICO 1965). Several U.S companies constructed vehicles, often from their own resources. Some of these companies were:

- 1962 - Perry Submarine Company [CUBMARINE series].
- 1964 - General Mills Corporation [ALVIN].
- 1964 - Litton Industries [completed ALVIN].
- 1965 - Reynolds Aluminum Company [ALUMINAUT].
- 1965 - General Dynamics Corporation [STAR I, II, III].
- 1965 - Westinghouse [DEEPSTAR 4000, DEEPSTAR 2000].
- 1967 - Lockheed Aircraft [DEEP QUEST].
- 1968 - North American Aircraft [BEAVER].
- 1968 - Grumman Aircraft [BEN FRANKLIN].
- 1968 - General Motors Corporation [DOWB (deep ocean workboat)].

In addition, both Douglas and Northrup aircraft companies considered getting into the field but never went beyond the conceptual stages. In the late 1960's the General Oceanographics Company entered the field with its successful NEKTON design submersibles (ultimately 3 were built). But most of the programs listed above failed under their original sponsors due to lack of a mission and high overhead costs. Only the ALVIN, built for the Navy, and the Perry submersibles are still active operations, although recently the BEAVER MARK IV was resurrected under the management of International Underwater Contractors, Inc. Also, there were a few other submersibles built on an individual basis by small companies or backyard mechanics. Few survive as active craft and all were in the 200- to 300- ft depth range.

A great deal of imaginative engineering went into all of these vehicles; each was designed, without government specification, to meet a perceived need in deep ocean exploration. Thus, a very broad base of technology for submersibles was developed although the overall level of effort (number of vehicles produced) was quite small.

It is of particular interest that most of these early submersibles were built by aerospace or related companies. Only in the case of General Dynamics were the vehicles built by an old-line, established shipbuilder (in this case, the Electric Boat Division of GD). This phenomenon demonstrated a risk-taking willingness to put forth new concepts in a little-known area. While society does not reward every case of risk-taking by the very definition of "risk," it is regrettable that the United States was unable to somehow preserve this technical capability. In an era where we seem to subsidize everything from agriculture to airline mail contracts, it would not have been too difficult to conceive of a practical work program for this national capability. In this way a great deal of important work could have been done by these vehicles while keeping the operational and technical capabilities intact. This was not done and now much of the talent has been dispersed.

Similar situations existed in other nations, but it was much more critical in the United States largely due to the scale of effort that was initially invested here.

## Submersibles at Work in the Sea

Parallel to the broad-based design and technical development of submersibles was their attendant application to a diversity of jobs in the ocean. At first most of these jobs had a ratio of luck to skill in the order of 80/20, but gradually operators learned how to exploit the full advantage of trained minds and eyes at work sites in the sea. The record has been remarkably good:

1963-64: TRIESTE I and TRIESTE II successfully explored the site of the sunken submarine THRESHER including removal of some selected pieces of debris for analysis.

1965: The submersible SUBMARAY was used to inspect a seafloor power transmission line in Puget Sound over a distance of several miles.

1966: The Canadian PISCES assisted in successfully raising a sunken tug boat from 670 feet in Puget Sound by attaching lifting lines around the hull.

1966: The location and recovery of the lost H bomb at Palomares, Spain, through a combination use of the submersibles ALVIN, ALUMINAUT, and Perry Submarine, and the unmanned vehicle CURV II (Cable Controlled Underwater Recovery Vehicle).

1967-70: The PISCES I submersible was routinely used to recover U. S. Navy experimental torpedoes from test firing ranges in the Puget Sound area.

1968: The STAR II together with DOWB located and recovered a nuclear power source off the California coast that had been part of a payload on an aborted launch of a satellite.

1969: The DEEP QUEST was used to recover the cockpit voice recorders and flight recorders from two commercial jet transports that had crashed in the ocean offshore from Los Angeles International Airport.

1969: TRIESTE II was used to inspect and analyze the wreckage of the lost nuclear submarine SCORPION near the Azores. First location was by the MIZAR.

1969: The Perry PC-9 was purchased by Brown and Root Construction Company and used for routing pipeline inspection in the Persian Gulf area.

1970: MIZAR located the lost French submarine, EURYDICE, and the French Navy's bathyscaph, ARCHIMEDE investigated the wreckage off Toulon.

1970: The DEEP QUEST located and the Navy recovered a World War II Navy Hellcat fighter in 3500 ft of water off San Diego.

This is, of course, only a brief summary. Also this list emphasizes working projects rather than scientific exploration. Scientific projects have had tremendous difficulty getting funded and this will be discussed later. But the decade of the 1960's did bring considerable progress to the techniques and skills of deep submergence . . . the "skill-luck" ratio was beginning to favor skill.

Looking back over the operational history of submersibles one cannot fail to be impressed with the variety of work done and the remarkable record of success. The question then arises why all of this has not become better known in the interest of expanding capability in this area. It is my opinion that we put the emphasis on the wrong part of the deep submersible story. The manufacturers and the people responsible for operating them tended to do a lot of publicity on the front end of the program in the best "brochuremanship" fashion but relatively little of this energy was put into the reporting and selling of results. Thus, in many ways, our failures to publicize and capitalize on the really good professional work that has been done has led to a general feeling of disinterest in submersibles.

There seems to be a generally accepted theory that the submarine THRESHER loss was the initiating point for the rapid growth and development of submersibles throughout the world (Link 1964). I do not subscribe to this position. It is true that the disaster focused attention on the very real limitations of submersible systems in existence and our capability to aid deeper diving nuclear submarines in distress. The Navy's Deep Submergence Systems Review Group (DSSRG) did undertake a careful and extensive review of existing submersible technology from 1963-1964 and this was of considerable help to the Navy in mapping out its deep ocean technology efforts. In addition it also led to the Navy's setting up of the Deep Submergence Systems Project (DSSP) and the design and procurement of the DEEP SUBMERGENCE RESCUE VEHICLE 1 and 2 (DSRVs) which are capable of rescuing submarine crews to depths of 5000 ft. Nevertheless, it was clear before the THRESHER tragedy that both manned and unmanned submersibles would be required to permit more extensive work in the world's oceans. Many were on the drawing boards, in production or in operation prior to April 1963. THRESHER served to accelerate only part of this broad group of activities.

### Current Trends

The recent history of submersibles has demonstrated some interesting trends in the development and use of these craft. First, we see an increasing coordination of the spectrum of manned activity in the sea. At one time many thought that diving systems would gradually phase out with depth due to predictable physiologic, technical, and operational limits. At this magic cutoff point the manned submersibles would take over. It has not been this simple. Improvements in diving techniques and costs have shown that finite limits of diving capability are at best elastic for the predictable future. The second point is the question of where man should be located in the overall

submersible and surface support-ship system. The advent of low-light-level TV's, remote manipulators, force feedback systems, and multi-axis operator control systems has brought the unmanned submersible into real prominence. Many proponents of these vehicles believe that man need not lose his effectiveness by staying on board the surface ship and controlling the vehicles through an umbilical cable. Finally, recent submersible accidents have demonstrated that effective recovery systems for these machines are not yet available and that in most cases of recovery of the crew or part of the crew, the luck factor has been high indeed (MTS 1974). The conclusion is that diving systems, manned submersibles, and unmanned submersibles form a spectrum of capability to do work in the sea. The choice of which system to use depends on the job, the costs, and the unique characteristics of each system.

Meanwhile, those charged with the professional development of these techniques have begun to recognize the high degrees of professional skills and training required to operate them. As potential hazards increase, so do costs of operations. One way to reduce risk costs is to satisfy insuring agencies of the care taken in the design, construction, and operation of these systems. Such groups as the American Bureau of Shipping, The Marine Technology Society, and the Deep Submergence Pilots' Association have taken the lead in the area of manned submersibles. Through standardization, specification, and regulation safety will increase and costs can come down (MTS 1968,1974).

We find today that almost all of the first generation submersibles are out of service. Some were born to be white elephants while others provided vital engineering and operational stepping stones to the capabilities of today. Only the ALVIN, the SOUCOUPE, and perhaps a Perry boat remain operational from this first generation of the early 1960's. Even ALVIN is not quite the original submersible since she received a new titanium hull and plumbing in 1973 that doubled her depth capability to 12,000 ft. Either the Cousteau SOUCOUPE or one of the early Perry submersibles probably ranks the title of "the last operational submersible of the first generation," essentially unmodified since original construction. All the rest are in boxes or cradles on shore somewhere or have been committed to museums.

The submersible designs that have tended to stay in the evolutionary development have been the small boats such as the General Oceanographics and the Perry Submarine Company series. They are small and portable, relatively cheap to operate, and are operated by crews who have extensive experience in the business. The orientation of these companies has been towards the commercial market rather than the government, thus keeping a good competitive basis relative to divers or surface-lowered systems. There are other companies that have followed this same path but these two are certainly the leaders. In the case of Perry, their business of building, leasing, and performing submersible operations took nearly 10 years before any substantial profits were realized (LaCerde 1974).

This is not to say the day of the large submersibles is over. The operational ARCHIMEDE, TRIESTE II and NR-1 (the Navy's nuclear powered deep submersible) all attest to the fact that there is room in the capability spectrum for such craft. It is apparent, though, that few vehicles of this size could

be supported by private agencies on a successful business basis. The U. S. Navy holds title to a submersible fleet of 10 vehicles, only 6 of which are under direct Navy fleet operation (TRIESTE II, DSRV-1, DSRV-2, SEA CLIFF, TURTLE and NR-1). The ALVIN, NEMO, and DEEP VIEW are in the hands of research institutions while the MAKAKAI is operated by a Navy laboratory. Many of these craft are in a "fire house" status where they are kept on-call to meet emergency situations anywhere in the world, at any depth capability required. Naturally the routine support costs of maintaining such a capability are considerable. Not only must the vehicles be maintained and crewed, they must also have extensive and dedicated mother ship support as well as a shoreside support base. It is predictable that such operations will never find their way into the world of commercial ocean operations except on an occasional reimbursable use basis.

Today there are more submersibles in operation throughout the world than ever before. The popular theme that the development of these craft stalled out by the late 1960's is just not correct. Certainly the first generation has largely passed on to obscurity but this was an evolutionary period of design, construction, and operation . . . too many people hoped for the revolution.

That few appreciate the contemporary scope of today's submersible operations can be attributed to two primary factors. The first is current interest in ocean resources development, primarily oil and gas. These industries do not need a lot of ballyhoo about "the magic of deep submergence"; they are only interested in getting the job done effectively and at least cost. If a submersible is competitive it gets used; if not, some other system gets used. The second factor is that capability is not seriously applied to oceanographic work (Ballard and Emery 1970).

In the 1960's, during the rapid expansion of submersible development, most of the demonstration work was actually given over to ocean science applications. To a great extent this part of the submergence business declined considerably with the demise of the first generation of submersibles. What is often forgotten is that there was never any real source of funding support by the ocean science community for the continuing use of submersibles. Almost all of the dives were either free or given at daily rate charges that were well below the profit level for the sponsoring companies. Thus, much of the gloom about the decline in the use of submersibles can be attributed to the oceanographers who sampled but could never get the necessary funding support to institute continuing programs of scientific diving. The efforts to get such funding were considerable and to this day there is a continuous investigation of the situation by various panels and committees representing government, academia, and industry (FCST 1972). Each of these studies shows that there is indeed a need for submersibles in support of science but the problem of how to secure financial support for the purpose has not yet been solved (NAS-NAE 1973).

Lack of support for submersibles mirrors a general malaise in government support of ocean sciences and engineering. When the primary oceanographic platforms, the research vessels, are being laid up for lack of funds, there

is little chance that any reasonable support for submersibles can be found. This is not to say that some regular work is not being done. The ALVIN has supported ocean science programs at the Woods Hole Oceanographic Institution for over 10 years, but those who have followed the program know the maintenance of adequate funding support has been very difficult. Recently, Texas A&M University's Department of Oceanography became the first academic institution to plan, budget, and procure a submersible in support of a university program. It was a Perry PC-14 boat and part of the purchase costs were donated by oil companies. There have been other submersibles donated to academic institutions (STAR III, DEEP JEEP, and DOWB to name a few) but none of them ever got into service with their new owners.

#### Prospects for the Future

The creation of the Manned Undersea Science and Technology Office (MUS&T) in the National Oceanic and Atmospheric Administration (NOAA) within the Commerce Department and the Navy's Submarine Development Group One at San Diego have given administrative and operational focal points to government support of submersibles. In addition, select committees of the National Academy of Sciences and the National Academy of Engineering have focused recently on the problem of manned undersea activities (NAS-NAE 1973). Finally, the University National Oceanographic Laboratory System (UNOLS), administered under the support of the National Science Foundation, the Office of Naval Research and NOAA, has worked out some programming for submersible support for oceanographic research. This has recently come into actual operation with a joint program for ALVIN which will be supported by these three agencies.

Nevertheless, the future is not too bright for submersibles in science due to the overall funding problems. In fact, the future can be indexed to the growth of support for ocean sciences and engineering in the United States. If this support begins to come back and to increase, then--and only then--will a general increase in the use of submersibles be seen in oceanography.

The development of the functional unmanned submersible has been a relatively recent phenomenon. This is not the old cable-lowered camera system that we have used for years but a versatile, multisensor maneuverable vehicle controlled through an umbilical by the operator on a mother ship. The majority of this work has been done by a division of the U.S. Naval Undersea Center (NUC) at San Diego where the CURV was developed and now a whole new family of related vehicles is under development. The past 5 years have brought considerable sophistication to detection systems (sonars, lasers, magnetometers, etc.), cameras, low-light-level television, multifunction manipulators, and complex feedback control systems. Probably no area of deep submergence systems has advanced so far in this period as have the unmanned deep submersibles. The man is still in the loop but he is physically not in situ as with the manned submersible. Depth does not seem to be a practical limit since the MIZAR system has been used in 16,000 feet of water and the Navy's new Remote Underwater Work System (RUWS) now being built by NUC will have a 20,000-ft depth capability. These systems offer

costs reductions by not having to have life support systems and avoiding design penalties inherent in man-rating a vehicle. These cost reductions can also translate to a smaller vehicle for the same capability, thus increasing portability.

I am still convinced that there is a major and expanding future for manned submersibles but I also welcome the increasing use of the unmanned systems in the complimentary spectrum of capability from diver to deep submersible.

The future for submersibles, manned and unmanned, is bright. I am convinced that we will see a dramatic increase in the small, highly transportable boats in support of industrial work in the oceans. The designs and technology will continue to be relatively conservative to hold down R&D and production costs. Within 10 years many of these boats will have a capability for routine work at 10,000-12,000 ft to permit operations across the continental shelves and down to the base of the continental margins; however, the majority of them will have about a 4000-ft capability which will match the offshore oil industry's projection of maximum drilling depth (for producing wells) by 1985. There will continue to be the development of the hybrid submersibles which have diver-lockout capabilities, and which may carry their own unmanned submersibles on board for hazardous situations where a diver or manned vehicle cannot get close to the site of interest.

I do not see any rapid development of the use of submersibles in support of ocean science and engineering at the research institution level until overall national support in these areas increases.

There will be continued governmental development of new ocean-engineering materials, systems, and techniques--mainly by the Navy--to improve capability of operating in the full depth range of the oceans. A great deal of this technology will be transferred to industry when cost savings or operational advantages gained are demonstrated. There will probably be very little industrial research in submersible engineering as such.

The major forcing function in world-wide development of submersible systems will be the energy crisis and the need to explore and develop ocean sources of petroleum as quickly and efficiently as possible. This means that there can be a rather good market developed for the supply of submersible equipment to the world's offshore petroleum industry. At present the United States, primarily through Perry, has a strong lead in this area. A similar marketing venture with the unmanned vehicles may well begin soon and U. S. interests will certainly have a lead here also.



## REFERENCES

- Ballard, R. D. and K. O. Emery. Research submersibles in oceanography. Washington, D. C., Marine Technology Society, 1970.
- Beebe, W. Half mile down. New York, Duell, Sloan and Pearce, 1951.
- Federal Council on Science and Technology (FCST), Interagency Committee on Marine Science and Engineering (ICMSE). Manned undersea activities of the federal agencies and utilization of manned undersea research submersibles and habitats. Washington, D. C., FCST ICMSE, U. S. Department of Commerce, 1972.
- Interagency Committee on Oceanography. Undersea vehicles for oceanography. ICO Pamphlet 18, October 1965. Washington, D. C., FCST, U. S. Department of Commerce, 1972.
- Keach, D. L. Down of THRESHER in bathyscaph. Nat. Geogr., June 1964.
- Link, E. A. Tomorrow on the deep frontier. Nat. Geogr., June 1974.
- LaCerde, J. New day dawns for submersibles. Ocean Ind., May 1974.
- Marine Technology Society. Safety and operational guidelines for undersea vehicles. Washington, D. C., published by the Society, 1968.
- Marine Technology Society. Safety and operational guidelines for undersea vehicles. Washington, D. C., published by the Society, 1974.
- Ocean Affairs Board and Marine Board. Civil manned undersea activity: an assessment. Washington, D. C., National Academy of Science and National Academy of Engineering, 1973.
- Piccard, A. Earth, sea and sky. New York, Oxford University Press, 1956.
- Piccard, J. and R. S. Dietz. Seven miles down: The story of the bathyscaph TRIESTE. New York, G. P. Putnam's Sons, 1961.
- Shenton, E. H. Diving for science: The story of the deep submersible. New York, Norton, 1972.
- Terry, R. D. The deep submersible. Los Angeles, Western Periodicals Co., 1966.

## B. LIMITATIONS OF SMALL SUBMERSIBLES: L. SHUMAKER

### Power Supply

Power requirements in small submersibles seem at this time to be their major limitation. One definition of a submersible is a boat that has a short-duration time and is very dependent on surface support. This is true, and it is also true to a large extent of power technology. For a small boat to submerge and perform the complex tasks needed there just isn't room for a nuclear power plant. For political reasons we probably won't see that for some time.

The primary power source for submersibles is still the lead-acid battery; this has distinct limitations. It has a poor power-weight ratio. We have gone in some cases, such as the DSRV and a few other boats, to the silver-zinc battery but it is turning out to have more problems per lb than the lead-zinc battery ever had. It's hopeful that we will see fuel cells as well as other types of power packages in the near future. One package is a closed-cycle brake turbine device using something in the form of carbon blocks or liquid salt to store heat. This has promise but, unfortunately, money and other problems are slowing down development somewhat.

Submersibles fall into size ranges: the smaller the submarine, the fewer lead-acid batteries it can carry and the shorter its duration potential. A smaller boat, such as NEKTON, is probably in the 2- to 4-hr time range. DSRV's are now running about 5 hr: ALVIN generally runs in the 8-hr range and DEEPQUEST has a 12-hr capability. The only submersible that had long-term staying power was the BEN FRANKLIN.

### Launch and Recovery

Another major area of limitations is the launch and recovery procedure. A cost of acquiring a submarine is only the beginning. A support ship with transporting, launching, and recovery capability is then required. Launching is difficult except under perfect weather conditions. Weather becomes a major limitation. There are many attempts being made to solve this through submerged launch and recovery techniques--for example, the DSRV will be launched utilizing the catamaran ASR. The elevator-type method of launch and recovery used by ALVIN and DEEPQUEST has not proven to have a much greater sea-state capability than previously used methods. It does provide more comfort and reliability with less chance of accidents associated with the heavy crane system. The most common current method of launching a submersible is by crane. One submersible pioneer said after witnessing such a launch during heavy seas, "It is really amazing, the scientific advances we have made: we used to destroy buildings that way, now we launch submarines." One other development which may be used before too long is the semisubmerged ship concept with an elevator to get the submersible under the surface of the ocean.

It looks like a very promising thing, but will carry a high price tag.

### Fatigue

Personnel fatigue is another limitation on small submersibles--although in most cases the battery runs out of energy before the human being does. This is particularly true of the diver who is deeply interested in what he is doing. As a general rule, my observation has been that anywhere between 8 and 12 hours, personnel fatigue begins to show. This is amazing considering that space is cramped, temperatures are either too high or too low, humidity is uncomfortable and so on. Moving around space is the most critical of this group.

### Waste Disposal

Design engineers tend to think of human waste disposal as a limitation. We have never found that to be a problem. Absolutely refraining from liquids for about 12 hr before each dive seemed to be the best solution of the problem. This procedure worked well for an 8-hr dive and was used by most of the boats in the command. Indeed it became a matter of pride to last throughout the whole dive; that is, until we began to make 12-hr dives routinely. After the second 12-hr dive, we utilized the sanitary facilities on board. DEEP-QUEST carried a sort of camper stool and a number of kinds of plastic bags; the system worked but with five people in the submarine it was messy sometimes. Again, the 8- to 12-hr range is not a severe problem. With much longer ranges and much longer times, attention must be given to waste disposal.

### Life Support Systems

Life support systems are not yet a direct limitation in that the amount of power we have limits the endurance of the boats. Present technology can very easily provide the amount of oxygen and the amount of CO<sub>2</sub> scrubbing needed. Indirectly, however, life support systems are limiting because of the safety requirements. These problems will be discussed in another section of this report. Everybody is taking a very hard look at the survivability of the submersible when, in effect, it cannot surface on its own. What sort of response time do the rescue systems have? Recent experiences indicate that it takes a minimum of 48 to 72 hr to get help to divers stranded on the bottom. Because of this, everybody is trying very hard to increase their life support capabilities. We in the ALVIN have increased ours to 216 man-hours, or 72 hours for the submarine. But even that is marginal. If one stops to think of the areas where a submersible might be operating and how long it would take to get assistance to it, 72 hr is very close. Considering storage space on board as related to the present approved state-of-the-art devices for providing oxygen and absorbing CO<sub>2</sub> without over-crowding the boat, it would be difficult to provide much more.

Life support technology is a subject that needs a hard look. There are many possibilities, such as external storage of life support materials. There are some beautiful methods for absorbing CO<sub>2</sub>, but most of them are

as yet too bulky for small submersibles. Lithium hydroxide seems to be the best thing we have right now. There is surely a better or more efficient system and I hope that we will find it soon. I think everybody would be more comfortable if we had at least a week's life support for these boats. I also believe that the medical people should review what sort of increased life support capabilities a diver may get by decreasing metabolic rate, once he knows he's in trouble. It is probably possible down to a certain point and then one crosses over the temperature areas and starts to get cold. At this point it becomes necessary to move around and warm up. We in the operational side of it have a feeling there is potential there. We know we can increase our supplies by slowing down; we also know that once we start to run into the cold problem there are diminishing returns. But we don't really have sufficient information. Possibly a lot of good work could be done and made available to the operating people. These are the sorts of things that it would be sensible to include in operational procedures. Our new pilots coming along should be familiar with steps they could take to conserve their life-endurance supplies.

### Communications

Another limitation area that became especially important to me personally at one time is that of communications. We should divide that into internal and external. Internal communication in the very small submersibles does not seem to be a large problem. They don't have a lot of noise-generating equipment. Usually a diver is so close to his partner that he can talk right into his ear without moving anyway. Some of the more sophisticated boats have a very noisy environment with compressors running, inverters and converters operating; this makes it very difficult to talk. The DSRV is a very good system, but internal communications, external communications, the sonar, and the fathometer feed into the same set of headsets. Any one could be turned off to use another but one day we ran into a problem and had to turn off the external communication system to use the sonar and to talk with one another about what was going on. When the problem had been solved, I forgot to turn the switch back to the normal mode. An hour later we discovered that almost the entire U. S. Navy was up there yelling for our hides because we had not communicated. Perhaps there is no simple solution to that problem but integration of communications systems is important in submarine design.

External communications is somewhat simpler; the limitations there do not seem to be very severe. Since the early days we have managed to converse fairly well with the people on the surface. Perhaps the only serious limitation is that the pilot often prefers not to talk to the people on the surface. People on the surface seem to want to keep up a steady communication. A compromise that has worked generally well for us is that we communicate every 30 minutes. Communications are good and, in general, very reliable. I know of no serious problem incidents. We do have a backup system that allows communication by code or by simple Morse--dot-dash words to express very simple things like, "I'm coming up; get out of the way," or, "I've got a real problem here."

## Fire Safety

Fire problems such as fire in the sphere can create a difficult situation. I'm always surprised that we have had so few incidents. The importance of this is obvious. Everybody new coming into the program is immediately concerned with the possibility of fire. We have been through one or two of the small ones. Mr. Li from Lockheed will remember a "little smoking" in the compartment one day. In fact it is rumored he lapsed into Chinese. The most important action, initially, is to carefully evaluate all of the materials that go into a submarine, not just from a flammability standpoint, but also for toxicity. At what temperature does the safe insulation material suddenly become a generator of some compound of chlorine that can tear your lungs apart. These things are sometimes overlooked in submersible programs. In most of the programs with which I have been associated we have used a great deal of precaution but that is not to say that there is not room for more research. Where there is an absolute need to put a capability into the submarine and a safe piece of equipment is simply not available, it may be necessary to accept a fire risk that would be greater than desirable. Hopefully it will be possible to eliminate as much of the undesirable material as possible. Clothing on the market today including nice colorful shirts and warm jackets may be very dangerous when put into a closed environment. There is always a possibility of fire and if these materials once catch fire, they may burn very quickly. Operators must make sure that people riding in the boats are not wearing this type of clothing.

I have been asked about women divers. At Wood's Hole women scientists dive, some regularly at 6,7, and 8000 ft. Lipstick, or any form of lip aid, are forbidden because those compounds can be very dangerous under certain kinds of conditions. Here again, it is the principle of eliminating the hazards first, and doing the best you can then to provide for the ones you can't eliminate.

I get into many arguments over whether CO<sub>2</sub> or dry powder extinguishers are best. Each of these have good and bad features. CO<sub>2</sub> released into the boat will immediately extinguish a fire, but it could also immediately extinguish the occupants; use of an emergency breathing system is necessary. If you have a closed-cycle system and you use your normal hydroxide system to get rid of the CO<sub>2</sub> it may take too long and of course exhaust the system for further use. The dry powder, on the other hand, does leave quite a mess and it is hard to clean up. So, as with most dangers, the best thing to do is to avoid the fire. Another alternative is to go on the boat's BTB system, or closed-loop system and let the fire burn itself out as the oxygen is used up. I have never put that alternative to the test, however.

There are many kinds of emergency breathing equipment. For a number of years operators simply carried a scuba bottle and went onto an open-circuit emergency system. This is acceptable for a very short duration, but it has always had one drawback--pressure buildup. There are many good, closed-cycle systems on the market today. Scott makes one and there are others. The system should be kept closed-cycle and isolated from the remainder of the environment.

## Escape

Some people look on the scuba emergency breathing equipment as an escape system also. It might be in a shallow situation. I have not piloted shallow boats that spend a large percentage of time in water where escape is a possibility. Most submersibles going to any depths at all will spend such a small percentage of time at shallow depths that to degrade any other system to provide an escape capability is really not desirable. I know I may get into a lot of arguments over this stand. My own feeling is that the submersible should be its own escape system. It should be designed and operated in such a manner that escape is never necessary. Obviously, there are times when this is not possible. But in most submersibles the hatch can't be operated without flooding the submarine. Further, unless you can flood the submarine very rapidly you are going to get into the decompression problem by the time you get out. Then rapid ascent to the surface will put you into pretty bad shape. I would much rather devote my attention to making the whole submarine safe and operable in such a way that I don't get into that unsafe position. Again, I do not wish to degrade any other system.

## General Limitations

There are a few other areas of limitation, rather general and artificial to some extent. Most small submersibles operate under some form of certification or classification. The Navy boats and the boats that are leased to or are operated for the Navy, all fall under the Navy certification program. This puts some very definite limitations on the boat and on its operations. There are numerous requirements under the certification program. The first requirement is thorough testing with documentation of all the systems. The pressure hull has to be sound, which is sort of a basic tenet. Each system is examined for occupant safety. In some cases it is undesirable to make a system certifiable because it imposes restraints that you may not want to have to meet. It may mean a redundancy that otherwise is not necessary. For example, in the case of ALVIN we felt early on that it was undesirable to certify our propulsion system under Navy rules. Certification would have meant that we had to provide almost a totally redundant propulsion system--redundant wiring and redundant power supplies--if it were to be a safety item. It would have made the boat much bigger and heavier, and not as flexible as we wanted it to be. We compromised with the Navy certification people by changing our operational procedures so that we would never operate underneath anything, such as an overhang, wire, or cable. In this way, no matter what might happen to the boat there would be straight-up access to the surface. Therefore no certification requirement was necessary for propulsion. This is just one example, among many others which places some sort of limitation on the submarine.

## Personnel and Training

Personnel and their training can provide a great limitation on the submersible. Without trying to be argumentative with development group personnel, I think the Navy, in their operational submersibles, go through an undesirable program of rotating people. This means that they have much greater training requirements on submersibles than we do with our very steady crew.

Our chief pilot has been there for 10 years. My number two pilot has been there for 5 years and so on. We don't have an ongoing training requirement. We are therefore able to operate with only one pilot all of the time. We have only one or two training or certification dives a year with the experienced pilots we have, and we are therefore always able to carry two observers with us. This adds a great deal to the capability of the submarine and increases efficiency. A very high training requirement constrains you to carry a pilot with the trainee, unless you have a lot of free time or free dives (which in my environment I don't often see). Training is also expensive. Finally, I think training of the other occupants needs discussion. This is not just training in the areas of life support and emergency procedures. We found out last summer on a very successful operation that our efficiency was increased by spending a week in the spring with the scientists, making dives and doing straight-forward training. Using their equipment, and through the use of the submarine, they learned how to observe efficiently out of the window. They remembered to push the right button on their tape recorders to advance the film in their cameras. In short lack of training of participants becomes a severe limitation on the submersible. I think that is a pretty fair catalog of the limitations.

## C. LIFE SUPPORT SYSTEMS: F. PARKER

Although I have been invited to speak on the general subject of submersible life support systems (which embraces a number of areas including atmosphere control, temperature and humidity control, food and water supplies, waste management, clothing, etc.), I wish to limit most of my presentation today to the two major parameters of the atmosphere control system--oxygen partial pressure control and carbon dioxide control. In addition, I will make a few remarks about a possible method of integrating a portion of the atmosphere temperature and humidity control system into the design of the submersible. I emphasize these parameters because the degree of optimization of these subsystems is related directly to the length of time the operators of a submersible will have available in the event of an accidental delay in recovery.

### Oxygen Partial Pressure Control

#### Permissible levels for oxygen partial pressure

Although man can function for an indefinite period at an alveolar oxygen level of 60 mm Hg (equivalent to breathing air at 10,000 ft), there is no advantage in selecting an oxygen level which will provide an alveolar  $PO_2$  below 100 mm Hg (equivalent to breathing air at sea level). For a nonhyperbaric system this requires a cabin  $PO_2$  of 160 mm Hg. To assure that the oxygen partial pressure is at least at this level it is necessary to increase the nominal control level to something higher than 160 mm Hg. This allows for some deviation due to control-system tolerances and nonhomogeneity in the cabin atmosphere. Nonhomogeneity problems can occur under hyperbaric conditions, where atmosphere mixing through gaseous diffusion is much poorer than is generally imagined even by many persons working in the field. Rather arbitrarily, a minimum atmospheric  $PO_2$  in the order of three-tenths of a standard atmosphere ( $PO_2 = 230$  mm Hg) is suggested.

It is sometimes desired to use a higher ambient  $PO_2$  than the minimum, particularly for lock-out submersibles, in order to decrease decompression time. The ever present danger of fire when the oxygen partial pressure is high, and particularly when both the oxygen partial pressure and percentage of oxygen are high, is not a topic for this presentation. However, it is something which must always be considered, not only in selecting a control  $PO_2$  level, but in the design of the submersible itself; it requires the elimination of possible ignition energy sources and careful material selection, etc.

Figure IC-1 shows several estimates of the upper physiological limit for the atmosphere oxygen partial pressure versus time. In selecting a control level, practical consideration must again be given to the fact that some degree of deviation will exist between the selected level and the actual control level. As the common failure mode of most oxygen sensors is in the direction



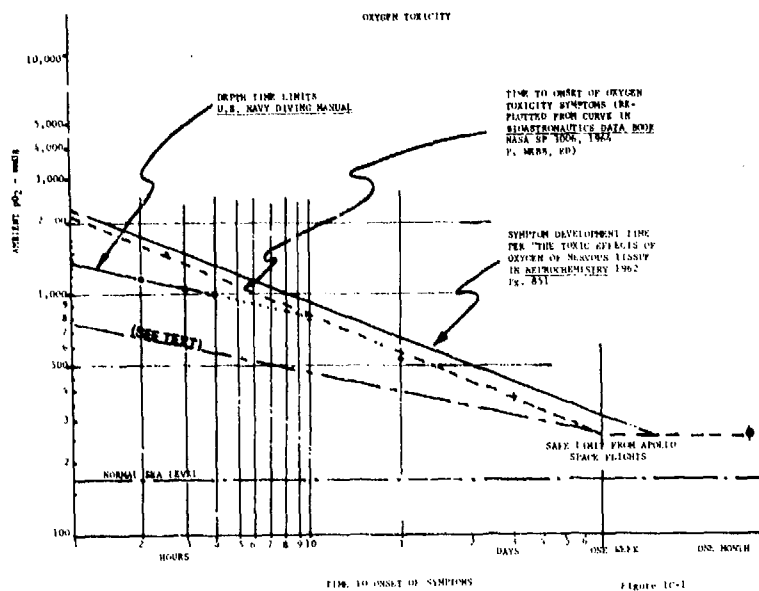

Fig. IC-1. Oxygen toxicity.

of decreasing signal (which causes controlled  $PO_2$  level to increase), it is recommended that the set level be substantially below the maximum levels shown. Unless there are compelling reasons to select a higher level it is suggested that the maximum set level be no more than that defined by the dashed curve drawn on Fig. IC-1, from the 760 mm Hg/1-hr point to the lower suggested level of 230 mm Hg, at 1 week. Again, these levels are quite arbitrary but are suggested assuming the absence of other overriding criteria.

#### Oxygen requirement

The amount of oxygen that a man uses varies with his physical activity level. Table IC-1 shows several examples of his oxygen-consumption rate when seated and engaged in the indicated tasks. An average oxygen-consumption rate over the course of a full day would be close to the very light work level. For design purposes, 24-hr consumption of about 1 kg/man can be assumed.

#### Oxygen control methods

Various ways of controlling the oxygen partial pressure are given in Table IC-2. The first is manual control. Because the oxygen partial pressure level changes quite slowly, it is simple to manually control the oxygen level, particularly if the oxygen-measuring instrument incorporates level alarms. However,  $PO_2$  is also easy to control automatically, which leaves the crew free for other tasks.

Table IC-1. Oxygen requirements

Work Classification	O <sub>2</sub> Consumption (liters/min)	Example
Very light work	below 0.6	Taking lecture notes
Light work	0.6 - 1.1	Light assembly
Moderate work	1.1 - 1.6	Rowing (pleasure)
Heavy work	1.6 - 2.2	Cycling rapidly (own pace)
Very heavy work	2.2 - 2.7	Cycling rapidly (13.2 mph)
Unduly heavy work	over 2.7	Sculling (100 strokes/min)

All activities performed sitting.

Table IC-2. Oxygen control methods

	Total Pressure Control	Semi-closed	PO <sub>2</sub> Control
Manual	-----		
Automatic	Only safe for relatively low total pressures	For relatively low total pressures and relatively fixed operating depths--i.e. TEKTITE- controlled atmosphere equals ambient pressure	Suitable for any depth and cabin pressure
	Only safe if there is no way by which a diluent gas can be added to the atmosphere.		

Total pressure control--Of the automatic control methods, the simplest is by means of total pressure control. As noted this method is only safe for comparatively low total pressures where the oxygen partial pressure forms a substantial percentage of the total pressure. Where the oxygen percentage is low, as in hyperbaric compartments, total pressure control deviation can impose an unacceptably high variation in the PO<sub>2</sub> level. Also this system is not safe if there is any possibility of leakage of inert gas into the cabin atmosphere.

Semi-closed system--For relatively low total pressure hyperbaric atmospheres, operating at a relatively fixed depth, and where the cabin pressure is equal to the surrounding water pressure, a semi-closed system for controlling PO<sub>2</sub> can be used. This system is limited in application because of the physical

constraints mentioned but is included because of its simplicity. In this system a gas (e.g. compressed air) is added to the cabin atmosphere at a rate such that the  $PO_2$  of the compressed air being added, less the desired cabin  $PO_2$ , multiplied by the flow rate, is equal to the average oxygen-consumption rate. Cabin  $PO_2$  will fluctuate somewhat with physical activity of the occupants, but in a relatively large cabin the variation will be modest. The flow rate would be adjusted if  $PO_2$  deviates too far from the desired level.

Automatic system--Perhaps the simplest of all systems is the completely automatic system in which oxygen is added automatically by means of a solenoid valve in response to a signal from an oxygen partial pressure-controlled activator. In such a system it is recommended that three sensors be used, unless it is simple to calibrate the sensors in the event of a disparity in readings; in which case two sensors are adequate.

$PO_2$  sensor--In each of the above systems an essential ingredient is a reliable oxygen partial pressure sensor, either for monitoring only, or for both monitoring and controlling (Fig. IC-2). Oxygen molecules enter the

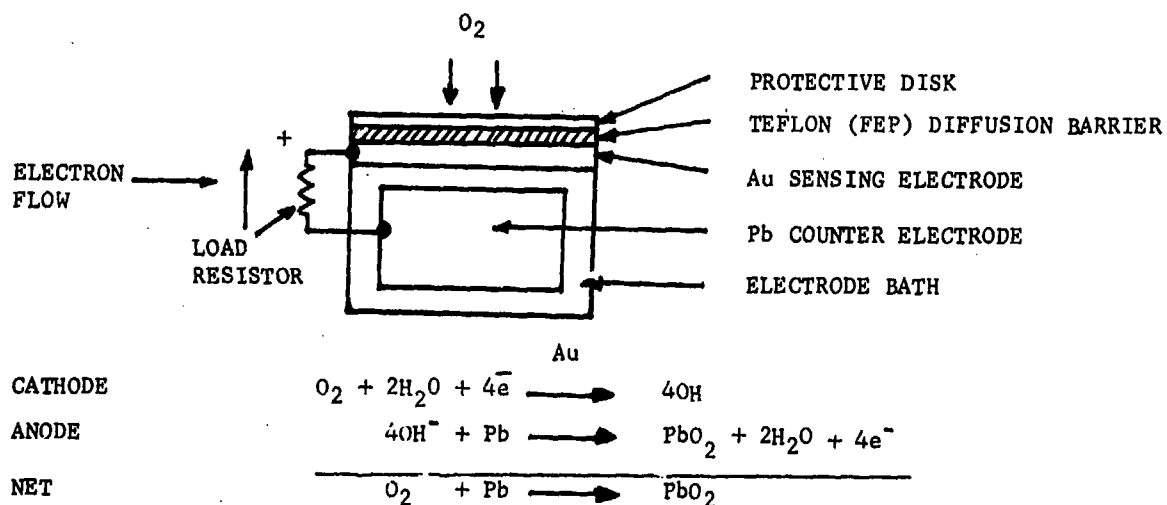

Fig. IC-2. Oxygen sensor.

sensor through a diffusion membrane at a rate proportional to the ambient  $PO_2$ . Within the cell they go into solution in the electrolyte and are reduced on the surface of a gold-sensing electrode, forming hydroxide ions. The electrons required to form the hydroxide ions are provided by the half-cell reaction in which hydroxide ions combine with the lead-counter electrode, forming lead oxide. The electron flow from the counter electrode to the sensing electrode is through an external load resistor, and is directly proportional to the diffusion rate of oxygen into the cell. The cell is temperature compensated (to account for the fact that the permeability of the membrane increases with temperature) by using a thermistor with an appropriate negative temperature coefficient of resistance as the load resistor across which the sensor output is read. The output of such a cell is adequate to drive a meter directly without requiring any additional energy source. Such an instrument, requiring only a sensor, a calibration pot, and the meter display



Fig. IC-3. Oxygen analyzer.



Fig. IC-4. Oxygen monitor with alarms.

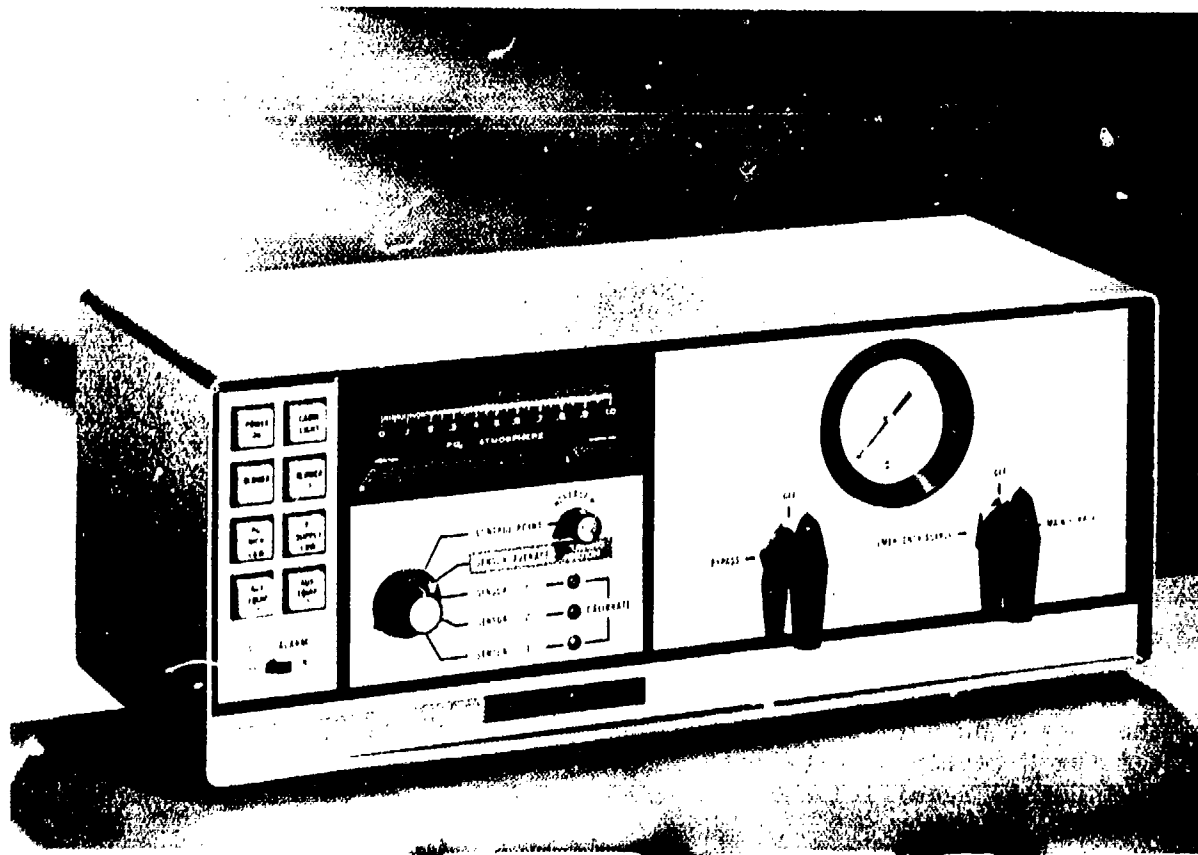
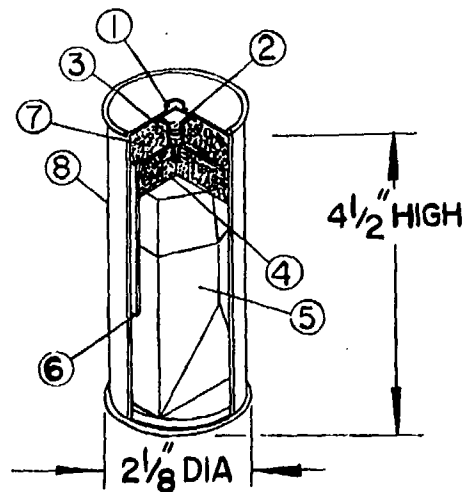

Fig. IC-5. Hyperbaric oxygen monitor controller.

is shown in Fig. IC-3. A more sophisticated instrument (Fig. IC-4) requiring a rechargeable battery, provides several scales to enhance reading accuracy. In addition it has both audio and visual alarms which are activated by individually adjustable high and low alarms. A still more sophisticated instrument (Fig. IC-5) averages the inputs of three sensors, rejecting the input from any sensor which deviates too much from the other two. When the average reading decreases to the control level a built-in solenoid opens, adding oxygen to the atmosphere until the cabin  $PO_2$  is increased slightly above the "add oxygen" level. Both audio and visual high and low  $PO_2$  alarms are included. The alarm is also triggered if a deviation occurs in the three sensor inputs. The selector switch on the face of the instrument permits the operator to read out the set control level, the average sensor reading, and each of the individual sensor reading.

#### Oxygen storage methods

Several methods are available for supplying the required oxygen--high pressure, solid, cryogenic, and superoxides and peroxides. The simplest storage method is high pressure gas. Solid oxygen is a useful way of carrying extra oxygen for emergency use. A solid oxygen device providing medically pure oxygen is shown in Fig. IC-6. This device is not restartable. When ignited, in a special canister, it produces its oxygen over a relatively short time. The 90 liters obtained from such a unit would raise the oxygen level only slightly, even in a small cabin, so the fact that it is added in a short period of time is not considered a disadvantage for submersible use.



SOLID  $O_2$  SUPPLY

90 LITERS (6 L/MIN. for 15 MIN.)

Fig. IC-6. Solid oxygen device.

Cryogenic storage, though reducing both container weight and volume from that required by the high pressure gas storage system, poses a number of design problems, and possibly a logistic problem. Used in conjunction with a  $CO_2$  removal system (by freeze out) it has interesting possibilities for a sophisticated submersible.

The superoxides and peroxides are used not only to supply oxygen but to absorb carbon dioxide as well. Oxygen partial pressure control can be a problem as the CO<sub>2</sub> removal rate and oxygen-production rate do not exactly balance the respiratory quotient (R. Q.) of the crew. This problem is magnified in the case of a hyperbaric compartment and would require the use of auxiliary equipment to control the PO<sub>2</sub>.

In summary, high pressure gaseous oxygen is the optimum method of storage from the standpoint of cost, logistics, controlability, and simplicity of system design. However, it carries something of a weight and volume penalty, which may or may not be significant depending on the overall submersible design constraints.

### Carbon Dioxide Control

Perhaps the single most important part of this presentation because it may well be the limiting factor in providing time for emergency recovery is CO<sub>2</sub> control.

A man's carbon dioxide-generation rate as a fraction of his oxygen-consumption rate defines the R. Q. for which we can--again somewhat arbitrarily--assume a typical value of approximately 0.82. That is, for each liter of oxygen consumed metabolically 820 c.c. of CO<sub>2</sub> will be produced.

The physiological effects of elevated PCO<sub>2</sub> levels as a function of time are shown in Fig. IC-7. A reasonable design level for submersible use is about 1% (of a standard atmosphere), or about 8 mm Hg.

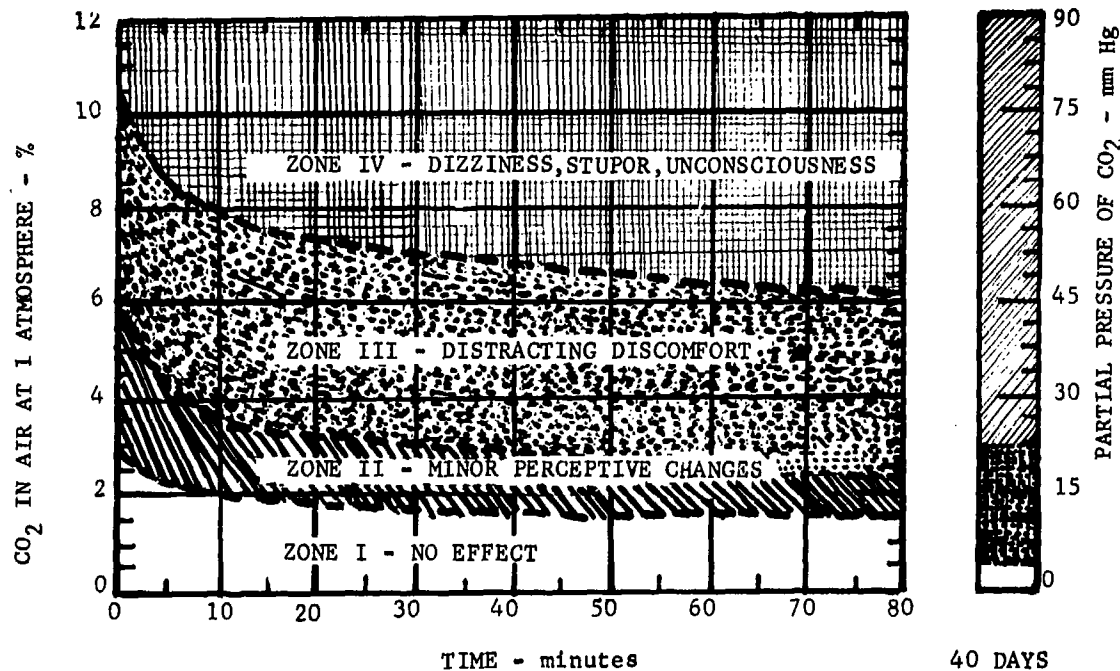

Fig. IC-7. Toxic effects of CO<sub>2</sub>. (This figure is reprinted from the NASA Bioastronautics Data Book, SP3006, 1973.)

## Carbon dioxide removal methods

Various methods for removing CO<sub>2</sub> from the cabin atmosphere are shown in Fig. IC-8. The first method is the simplest and most reliable, assuming proper design of the scrubber system. The various metal hydroxides react with carbon dioxide to form carbonates and water. We will discuss this method of removal in more detail later.

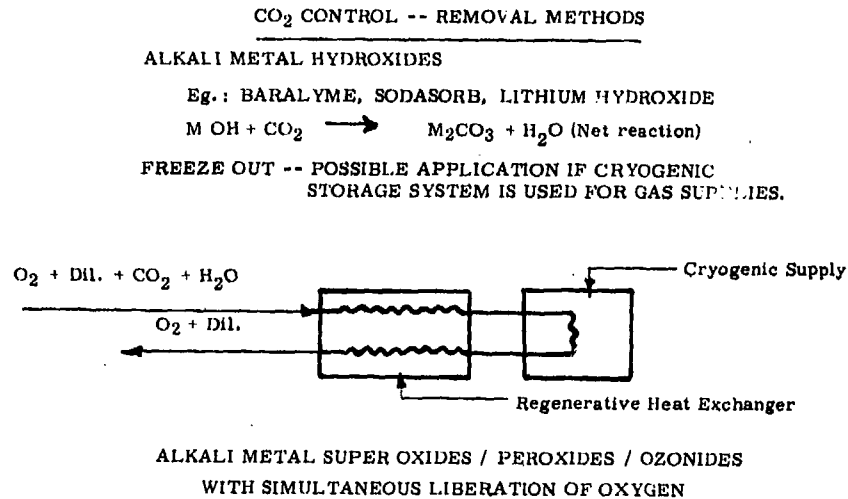

Fig. IC-8. CO<sub>2</sub> control.

The second method has already been referred to, freezing out the CO<sub>2</sub>. As shown schematically, a regenerative type heat exchanger is assumed in which the inlet gas to the cryogenic system is chilled by transferring its heat to the scrubbed gas leaving the cryogenic heat exchanger. This is necessary to prevent excessive boil off of the liquid oxygen. CO<sub>2</sub>, water vapor, and other relatively high freezing temperature contaminants are frozen out within the heat exchangers--which of course must be designed with adequate capacity to hold the frozen contaminants.

The third method of CO<sub>2</sub> removal superoxides and peroxides, was also previously mentioned, as was a significant drawback to its use. In addition these chemicals tend to be quite expensive.

Other possible methods of removing CO<sub>2</sub> involve the use of regenerable absorbents-adsorbents, of which a number exist. However, practicality would limit their use to larger, long-duration submersibles. The regenerable systems, though energy consuming, do have the advantage that large amounts of expendable absorbents need not be carried. Still other rather sophisticated methods of removal are possible--such as concentrating the CO<sub>2</sub> by means of perm-selective membranes and then transferring it to the ambient water by diffusion. To my knowledge these latter techniques have not been developed sufficiently to make them practical for application, at least in the near future, to the class of submersibles we are presently discussing.

Now, to get back to the first method of removing CO<sub>2</sub> (absorption by metal

hydroxides), certain design parameters are important to successful operation. Table IC-3 lists a number of design criteria.

Table IC-3. Design criteria

CHANNELLING	REACTION TIME	LOW TEMPERATURE
Relatively short flow path	Adequate volume of chemical	(causes reduction in reaction and excessive hydration)
Good flow distribution	Fixed installation Portable system	Insulation/heating

POOR DIFFUSION AT HIGH PRESSURES

Reduce size of granules	Increase reaction time
Increase porosity of granules	Improve distribution
Type of chemical	Increase temperature

Channeling and pressure drop--Channeling occurs in a scrubber when a substantial portion of the gas ducts through a low-resistance path (caused for example by settling of the absorbent granules) instead of distributing in a proper manner around each of the granules. The result of course is that the carbon dioxide in the high-velocity flow path is largely unabsorbed. To prevent this several techniques are commonly used, including shaking of the canister to settle the granules when filling the canister and applying spring pressure to the granules--after filling--to keep them compacted. These techniques help considerably, but they do not solve the problem. The most helpful approach is to design the canister with a large cross section normal to a short flow path, i.e. with a small length to diameter ratio. Then, if a flow distributor is placed at both the canister inlet and exit, this serves to distribute the flow evenly throughout the bed; the pressure drop through the granules only accounts for a relatively small part of the overall pressure drop through the canister. However, because the cross section of the canister is large the absolute value of the pressure drop is still very low. This is important because flow work is a function of the flow volume multiplied by the pressure drop. Consequently, the scrubber-blower power increases linearly with flow resistance. More importantly for equipment in which the man supplies the flow energy, the absolute work of breathing increases dramatically with pressure drop due to the very low mechanical efficiency of breathing (about 3 - 6%). For hyperbaric environments, and particularly where the user engages in extra vehicular diving operations (where his respiratory musculature is already severely taxed), it is most important to design for maximum pressure drop. In this context it is very significant to consider the advantages of laminar flow (which occurs at low Reynolds numbers) over turbulent flow.



The Reynolds number,  $R_D$ , is equal to a characteristic dimension of the cross section of the flow path,  $D$ , multiplied by the flow velocity,  $V$ , times the gas density,  $\rho$ , divided by the gas viscosity,  $\mu$ , or:

$$R_D = \frac{DV\rho}{\mu} \quad (1)$$

The general expression for pressure drop is:

$$\Delta P = 4 f \frac{L}{D} \frac{\rho V^2}{2g} \quad (2)$$

where  $L$  is the length of the flow path,  $g$  is the acceleration due to gravity,  $f$  is the friction factor.

For laminar flow the friction factor is equal to 16 divided by the Reynolds number. Making this substitution the expression for pressure drop becomes:

$$\Delta P = \frac{32 \mu L V}{D^2 g} \quad (3)$$

Pressure drop in laminar flow is therefore linear with velocity and independent of gas density and consequently, pressure. The only property remaining is the viscosity which increases only slightly with pressure.

The significance of these calculations is that the flow distributor (and indeed the entire scrubber) can be designed so that flow takes place in the laminar flow range (by virtue of the fact that "D" can be made very small for the flow paths through the distributor and between absorbent granules). Consequently, if the scrubber is designed for a low pressure drop at 1 atm it will remain low even under hyperbaric conditions.

Reaction time--The  $CO_2$ -containing gas must be in contact with the granules for a significant period of time so that the  $CO_2$  can diffuse into the granules. For a given flow rate through the canister, reaction time is proportional to the volume of the chemical bed, and independent of the bed shape. In a cabin-scrubber type of installation it is advantageous to use two canisters in series, with one canister at a time being replaced. When replacing a canister the upstream canister, and a new downstream canister is inserted. In this way the total volume of the absorbent is made large and only the most thoroughly used portion is discarded.

For portable systems, in which the crew exhales directly into the scrubber, the free volume (surrounding the granules) should be at least as great as a large breath so that each exhaled breath is retained in the bed for a full inhalation-exhalation cycle.

Low temperature--A low absorbent-bed temperature has two deleterious effects. The first is that reaction times are increased. The second, and more significant factor, is that condensation occurs on the surface of the granules and on the walls of the canister--from which it is soaked up by the adjoining granules. The liquid water excessively hydrates the surface of the granules,

forming a solution which glazes the surface and physically impedes the transfer of carbon dioxide molecules to the active reaction sites within the granules. Furthermore, if the gas is dehydrated adequately (due to a very low bed temperature) the reaction rate is very seriously impeded because it is possible to dry the chemical absorbent granules to the anhydrous state. As the presence of water is necessary in the overall reaction (carbonic acid is first formed, which then reacts with the metal hydroxide) the presence of the anhydrous chemical becomes a major problem. Figure IC-9 shows the hydration states of lithium hydroxide as a function of the water vapor partial pressure and temperature. Similar curves exist for the various other metal hydroxides of interest. As long as the chemical remains within the central band, i.e. as a monohydrate, good absorption can be expected.

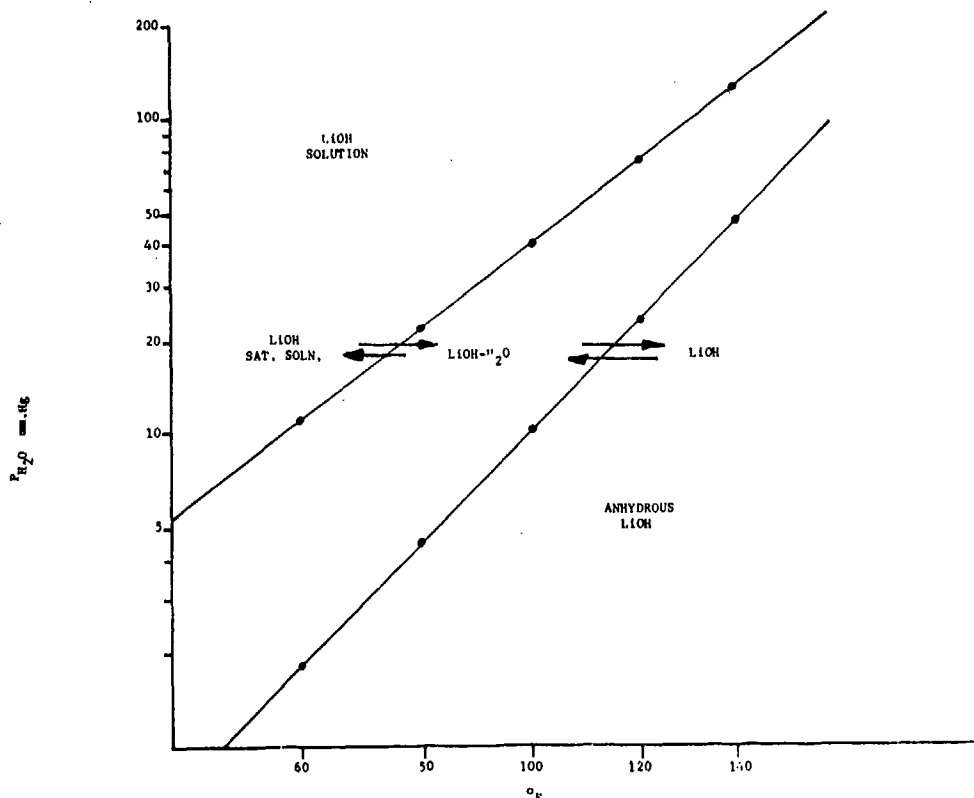

Fig. IC-9. Hydration states for LiOH

In many cases the low-temperature effects can be largely eliminated by insulating the inlet gas-flow path and the canister. This would prevent the inlet temperature and absolute humidity level of the inlet gas from dropping too low and would retain the heat generated during the actual reaction within the bed. Heating (and humidification) of the inlet gas may be necessary if the scrubber is to be used at very high pressures and very low temperatures.

High pressure--When a  $CO_2$  scrubber is used under hyperbaric conditions diffusion rates are radically decreased and it is a problem for the  $CO_2$  molecules to reach the deeper reaction sites within the granules. Under these conditions, reduction in the size and density of the granules is beneficial.

A chemical (such as lithium hydroxide) with better low-temperature performance may be indicated for certain applications. (NOTE: Applications can be limited by cost, alkalinity, and the highly irritating effect of the dust on the respiratory tract.)

In addition, previously discussed factors including reaction time, gas distribution, and temperature control become increasingly important as the density of the gas increases and must be considered in the scrubber design.

Temperature and humidity control--Temperature control is not a major problem in a 1-atm compartment, although humidity control may be due to condensation on cold walls and equipment.

In lock-out compartments heat loss from the crew to the hyperbaric environment can be a major problem in the event of delayed recovery. Heat loss occurs via a number of routes: evaporation (sensible and insensible), radiation, convection (free and forced), and respiration. The first two do not increase with increasing pressure. The third, convection, can be controlled by providing adequate clothing. The two applicable expressions for convective heat loss are:

$$\text{FREE CONVECTION. } h_c = \frac{0.55K}{L} \left[ \left( \frac{C_p \mu}{K} \right) \left( \frac{L^3 \rho^2 g \Delta T}{\mu^2 T} \right) \right]^{1/4} \quad (4)$$

$$\text{FORCED CONVECTION } h_c = \frac{K}{D} C_1 \left( \frac{DV\rho}{\mu} \right)^{0.8} \left( \frac{C_p \mu}{K} \right)^{0.3} \quad (5)$$

Table IC-4 lists the values of the gas properties for both nitrogen and helium.

Table IC-4. Values for room temp. at 1 Atm.

Property	N <sub>2</sub>	He	High Pressure Effect
Conductivity = K BTU/hr. ft <sup>2</sup> °F/F	0.015	0.082	very small increase
Viscosity = μ#/Ft. hr.	0.045	0.050	small increase
Density = ρ#/Ft. <sup>3</sup>	0.072	0.010	approx. linear with press
Specific heat = C <sub>p</sub> BTU/#°F	0.250	1.24	very small increase

At hyperbaric pressures, heat loss is increased from increased density. When helium is used there is a sharp decrease in the density but this is offset by the large increase in conductivity. In any case, as mentioned earlier, convective losses can be controlled by the provision of adequate clothing.

The amount of heat lost by the fourth route, respiration, is directly proportional to pressure. At 1 atm respiration losses account for only a small proportion of the overall body heat loss but, at very high pressures and with a cold breathing medium, the heat loss becomes intolerable. No amount of clothing can solve the problem. The only solution is to raise the inhaled gas temperature to an appropriate level. As electrical energy is liable to be in short supply during a protracted recovery period, insulation of the cabin seems to be a requirement.

A possible design approach to obtain the required insulation is to build a double wall hull. In this approach, air is forced (or permitted to flow by natural convection) between the pressure hull and an insulated inner wall. Condensation will form on the outer wall and maintain the inner compartment in a dry condition. Temperature control would be achieved by controlling the circulation rate of the atmosphere between the two hulls.

Emergency breathing systems--It may not be practical from the standpoint of power consumption to maintain the normal installed CO<sub>2</sub>-removal system in operation for protracted periods of time (for example, in the event of a mishap which requires surface-assisted recovery of the vehicle). For such situations it is advisable to provide a back-up breathing system which is not dependent on ship's power for blower operation. This system would also be available as a back-up in the event of blower failure in the primary unit.

Such a system is shown in Fig. IC-10; it consists of a CO<sub>2</sub> scrubber, a mask, and an oxygen monitor. O<sub>2</sub> make-up to the cabin is accomplished manually. Fig. IC-11 shows a completely automated closed system incorporating three oxygen sensors, the average of which is used to control the oxygen partial pressure. Should one of the sensors deviate in output from the other two, its signal is electronically limited so that the two sensors with the same output control the PO<sub>2</sub>. A panel incorporating controls and displays is provided so that the operator can monitor the system and override the automatic features if he so desires. Diluent gas is automatically added to the system should the pressure in the submarine compartment be increased. This system has the advantage (because it is closed) that it provides a clean atmosphere in the event that the compartment atmosphere is contaminated by products of combustion, or by any other means. Essentially the same closed circuit, packaged as a swimming rig, is seen in Fig. IC-12; this unit can do double duty as a piece of diving gear for extra vehicular activities (for submersibles with lock-out compartments) or act as a closed life support system for onboard use in the event of an emergency.

Summary--In summary, I have directed most of my remarks to means of optimizing a CO<sub>2</sub> scrubber, utilizing metal hydroxide absorbents, because it is presently the most practical method of control for small submersibles. The amount that can be carried is limited because of the considerable bulk of the



Fig. IC-10. Hyperbaric CO<sub>2</sub> scrubber and oxygen monitor (with alarms).

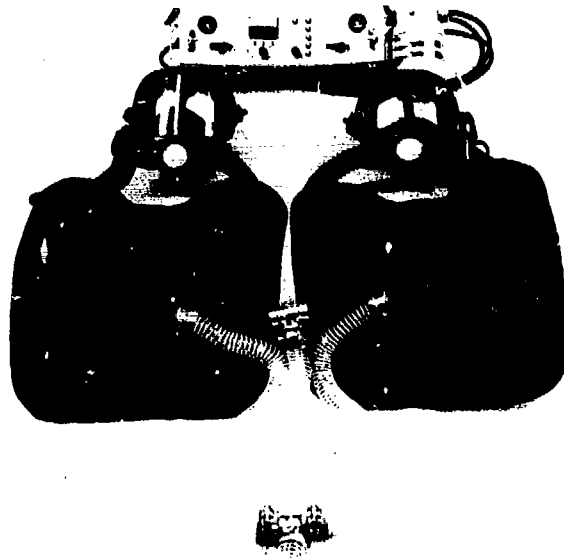

Fig. IC-11. Emergency closed life support system.



Fig. IC-12. Closed-circuit diving gear (500-ft lock-out dive, Bahamas, Dec. 1974).

chemical. Therefore, the amount of time available for recovery of the crew in the event of a mishap is directly related to the efficiency of the scrubber system.

Oxygen requirements, storage methods, and methods of partial pressure control have also been discussed and in each area typical, presently available equipment, both automatic and manual, have been shown. Finally, the problem of maintaining an adequately high inspiration gas temperature in a hyperbaric compartment during a protracted delay in recovery has been briefly examined.

## D. DIVING SUPPORT FOR MANNED SUBMERSIBLES: H. PASS

### Divers

Divers, as employed by Vickers Oceanics, are in fact surface swimmers using scuba gear and wetsuits. They are called diver/maintainers because, in addition to support diving, a V.O.L. diver also works on the submersible system. When recruiting divers, V.O.L. is therefore looking for men who, in addition to being experienced divers, also have expertise in electricians, electronics, or hydraulics/mechanics. They must also, of course, be physically and mentally fit, over 18, and have diving experience and qualifications through the British Sub-aqua Club, the Royal Navy, or similar bodies.

One of their primary roles is assisting in launch and recovery of submersibles from mother ships. It would therefore, as an introduction, be appropriate to look at a typical operating unit that V.O.L. employs in its offshore work. VICKERS VOYAGER, a converted stern trawler of some 4500 tons and 275 ft length, carries a crew of 29 plus up to 20 supernumeraries, comprising operations personnel, charterer's representative's, etc. P III is a PISCES-type, 2-3 man submersible with a 3000-ft depth capability. Diving support consists of a team of three men: a diver, a stand-by diver, and a Gemini driver. The standard procedure for a launch and recovery is discussed below.

### Launch

The Gemini driver checks his boat prior to a launch and runs through a check list to see that the Gemini is fully equipped. He wears an orange flotation suit and carries a VHF radio, which he also tests. The Gemini plus the driver and stand-by diver is then lowered into the water and takes up a position on the stern quarter. On board the mother ship, the diver has climbed onto the submersible which, with its crew aboard, has had the lift-line and tow-line attached. The submersible is then hoisted clear of its trolley until the diver can engage the handling gear strops onto the submersible's lifting hook, which steadies the submersible during launch. The diver signals that he has done this and the lift-line is slackened to put the full weight of the submersible on the strops.

Using the tow-line as an extra steady, the handling frame is then rammed out with the diver standing up and holding on to the lift-line. When fully rammed out, the weight is taken again on the lift-line to allow the diver to disengage the strops. He signals that this is done and the submersible is lowered into the water up to the level of her propulsion motors. The last part of the actual launch is made quickly in accordance with wave movement to prevent any snatch on the line. The lift-line is then fully slackened and the diver uncouples the shackle. The tow-line is paid out until the submersible is some 50 ft astern of the ship, which during launch and recovery heads into the sea. At this point the ship stops to slacken the tow-rope and signals the

diver to disconnect the tows. Entering the water, the diver releases the tow, holding the snap-hook aloft to show that this has been done, removes the camera lens cover, and remounts the submersible. The Gemini closes the submersible and the stand-by diver passes to the diver the marker buoy-line, which the diver connects to the submersible and signals having done so. The ship then gives the submersible clearance to dive and the diver assists by flooding the sail. When the submersible has sunk under him, the diver climbs aboard the Gemini.

The two men in the Gemini have been paying out the buoy-line and when the submersible signals "on bottom" the buoy is tied on with about 20 ft of slack. The Gemini then returns to the ship and the diver stays in his suit on the ship with his gear in the Gemini for the duration of the submersible's dive.

### Recovery

The Gemini carrying the driver and stand-by diver collects the diver from the stern of the ship and moves out to recover the submersible's buoy. When the buoy has been recovered, the Gemini driver signals the ship and the ship tells the submersible that it is "Clear to ascend." As the submersible rises, the men in the Gemini take in the buoy-line and flake it neatly into the "dustbin." When the submersible has surfaced, the Gemini driver checks its buoyancy, i.e. looks at how the submersible is lying in the water, and orders her tanks to be fully blown if necessary. The diver then transfers from the Gemini to the submersible.

Returning to the ship, the Gemini collects the tow-rope from amidships but stays alongside the ship, which is manoeuvring to bring the submersible abeam. As the ship steams slowly forward, the Gemini peels off and delivers the tow-line to the diver who is now in the water. He connects the tow-line, replaces the camera lens cover, and remounts the submersible. This is the signal for the ship to start pulling in the submersible until she is positioned under the lifting gear. The main lift-line is lowered, the diver connects the shackle, and the submersible is hoisted clear of the water. When the submersible is fully raised, the diver hooks on the strops, holding them in position as the lift-line is slackened to put the full weight on the strops. The handling gear is then rammed in. Taking the strain on the lift-line again allows the diver to ensure that the strops are free and the submersible is lowered onto its trolley.

As can be seen, it is the diver and the Gemini crew that have most contact with the elements. Therefore diver safety is of prime importance when devising operational procedures. In fact the determining factor in the rough weather limitation on our activities, usually sea state 5/6, is the safety of our diver and Gemini crew. It is therefore very important that we recruit men of sufficient mental and physical "robustness" to work in such an environment and at the same time be useful members of the technical back-up team for operations.

Training of such men entering the Company is comprehensive, including all modern visual aids, practical training in both day and night situations,



launch and recovery in calm water, etc. Even after completing the training course, a diver will still be working only with other qualified divers until he is proficient.

E. SELF HELP, RESCUE, AND RECOVERY: LCDR D. HALL USN

#### General Characteristics of Deep Submergence Vehicles

Deep submergence vehicles are designed to perform specific oceanering tasks and therefore the size, hull, form, and equipment arrangements are quite different. There are a number of common characteristics, however, which exist in this group of vehicles. Most of these systems have a life support capability of less than 24-hr duration. The size and configuration of their hatches is such that they are not compatible with the McCann rescue bell or the U. S. Navy's Deep Submergence Rescue Vehicles. Exceptions to this situation are presently underway in the form of a future International Hydrodynamics submersible and a proposed Dutch boat, the NERIED 2000, which will have a portable rescue capsule that can be connected to the downed vehicle.

A review of most standard submarines shows that they are not specifically designed for efficient or effective individual escape. Deep submergence vehicles are no exception. In fact, ambient egress leading to buoyant-assisted, free-breathing ascent is impossible. The only exceptions to this are vehicles with diver lock-out potential (assuming enough gas on board to pressurize lock-out compartment to the bottom at a rate commensurate with an effective compression-decompression profile) and boats which can be completely flooded (shallow casualty where whole boat is flooded and personnel egress).

#### Emergency Situations Possible

Shallow water emergencies--that is, ones which occur in less than 100 ft of sea water where scuba diver assistance is available--require the following action: the pilot can increase buoyancy, have the submersible raised by winch, or flood the pressure capsule and make a free ascent. The surface-support vessel must locate the submersible, put divers down to assess the situation, communicate with the boat, and attach lines and haul it to the surface. A call for assistance is also mandatory at the same time.

Deep water (greater than 100 fsw) casualties require the same pilot action with the exception that diver assistance will probably not be available. Surface action requires that the support vessel be prepared to remain on the scene for not less than 72 hr. Precise navigational fixes should be taken. A moored buoy or sonic marker should be launched. A record of the submersible position relative to the surface unit should be noted.

If a fire occurs in the pressure capsule the pilot should cut off electrical power to the affected equipment, don emergency breathing equipment, and use the chemical fire extinguisher if necessary. Emergency surface should be initiated and, once on the surface, personnel should be evacuated and the sphere ventilated.

In the event of collision or flooding submerged with indication of leaks

or grounding, emergency surface is dictated.

If oxygen or other compressed gases leak into the sphere the following action is required: if the leak is uncontrolled, the pilot should emergency surface. Should the oxygen content be elevated above 30% the pressure capsule must be isolated from its power supply after emergency surface action. All flammable material should be isolated. During the last hundred feet of ascent the hatch should be undogged to allow relief of pressure and personnel should be instructed to breathe normally.

Excessive grounds or leak indications require discontinuance of dive, commencing of surfacing procedures, and possibly emergency surface.

If major equipment malfunction occurs, such as a loss of communication for greater than 30 min, the dive must be aborted and the vehicle should surface. Once on the surface a sail strobe light should be activated, communications should be established (if possible), directional fix procedures should be initiated, a radar target should be installed, and a darkness and underwater light and emergency flares should be activated.

If an unusual hazard of a specific dive develops, the surface should be informed and ascent procedures should be initiated.

#### Responsible Parties in Non-U. S. Navy Event Submiss/Subsunk

The United States Coast Guard has the responsibility to develop, establish, maintain, and operate rescue facilities for promotion of safety on, under, and over the high seas in U. S. waters. To this end they maintain a national search and rescue plan which includes rescue coordination centers (RCC) and communication networks (ships, planes, shore activities) and which has the authority to call on other Department of Defense Agencies. Their on-scene capabilities include the units to enable search for a vehicle separated from its support ship, delivery of scuba divers who may attach lift lines at less than 150 fsw, clearing the area of spectators, tow and escort of recovered vehicle, and the overall coordination of the rescue. If the above resources regarding submersibles are inadequate the Coast Guard calls on the U. S. Navy.

The United States Navy has the responsibility to use its own resources which may include a variety of available surface ships, submersibles, and diving systems. In addition the Supervisor of Salvage may call on other institutions and commercial organizations to enhance its rescue capability.

#### Action Initiated for Non-U. S. Navy Event Submiss/Subsunk

When a deep-submergence vehicle support ship calls for assistance on the International Distress and calling frequency (2182 Khz, 156.8 Mhz), the following procedures should be initiated:

1. A hot line to the proper Coast Guard facilities and other appropriate military organization is activated.
2. The rescue coordination center is informed.

3. The Coast Guard may initiate the planned Mutual Assistance Rescue and Salvage Plan (informal agreement between commercial submersible owners/operators).
4. The Coast Guard requests the U. S. Navy Department Duty Captain to initiate event submiss/subsunk. This action which takes place in the Washington, D. C. area includes the following:
  - (a) The Navy Department Duty Captain alerts the entire Navy underwater capability including the Secretary of the Navy, the Chief of Naval Operations, the Supervisor of Salvage, Commander Submarine Development Group One and others.
  - (b) These organizations initiate their assigned tasks which include direct liaison with the Coast Guard, coordination of CNO's action, making ready for search, rescue and recovery operations, furnish material requirements and support, and notify next of kin if Naval personnel are involved.
5. The USCG sends a message to the Chief of Naval Operations requesting support.
6. USCG alerts its normal search and rescue personnel in the immediate area. This includes concerned submersible owners and operators, the Area Commander, and other Coast Guard and U. S. Navy personnel.
7. The USCG Area or District Commander designates the senior U. S. Naval Officer as On-Scene Commander.
8. Commander Submarine Development Group One responds to this alert by assembling all information on the particular vehicle in trouble, reviewing charts of the operations area, determining the availability of assistance items in the immediate area and getting them to the scene, and providing staff personnel as advisors to On-Scene Commander.

#### Action Initiated for U. S. Navy Submarine or U. S. Navy Contract Submersible

In this case the U. S. Navy initiates its own procedures, which includes establishing an event submiss/subsunk by the Submarine Operation Authority in the concerned area.

#### Limitations of Outside Resources

The U. S. Coast Guard's national search and rescue plan is quite elaborate but, in the area of submersibles, only a limited capability exists.

The U. S. Navy's resources, which include an extensive inhouse underwater capability plus access to other institutions and commercial deep submergence organizations, are better prepared to respond to submersible casualties. Unfortunately a number of serious constraints blunt this otherwise viable arsenal of weapons. Rescue resources are positioned in only a few locations. Deep-submergence vehicle accidents may and usually do occur in remote locations. Local resources relative to the accident scene might be in overhaul, under repair, or personnel may be dispersed. One must always keep in mind the fact that the U. S. Navy's number one priority is the nation's undersea combatant forces. Therefore, at this time it becomes obvious that organizations employing submersibles may have to rely entirely on their own resources in the event of an underwater accident.

### Self-Help Capability

Previous discussion of the general characteristics of deep-submergence vehicles and the variety of emergency situations possible fix the possible approaches open to vehicle operators in the area of self-help.

Individual independent escape in the form of buoyant-assisted, free-breathing ascent has been shown by the United Kingdom to be possible at depths greater than 600 fsw. Unfortunately the configuration of most deep submersibles makes this method impossible. If, however, personnel aboard these vehicles are properly qualified in the boat's limited escape systems and emergency procedures and are knowledgeable of the limitations of the methods available, escape may be possible at shallow depths.

Group escape offers an attractive alternative to passing men through the water, thus exposing them to the full spectrum of physiological hazards. But, at this time, removal of personnel from a submersible using a group-escape concept is quite limited at best. Transfer of personnel utilizing another submersible is possible but as yet is untried in the open sea. As previously mentioned, DSRV-like vehicles are planned. Modified personnel-transfer capsules with adaptation skirts have been suggested and represent a viable concept, given ideal surface and subsea environmental conditions. Additionally, the problem of proper interfacing with the particular vehicle will always present difficulty. The roving bell configuration to support either air or mixed gas divers may extend surface-supported diving depth limits but again is only useful when environmental conditions are ideal.

Of the three approaches available to recover personnel from the bottom, the most sensible at this time appears to be rescue by salvage. Recent experience with deep submergence vehicle rescue and recovery utilizing another manned or unmanned search and recovery system has shown to be workable in the open sea. Air or mixed gas divers have had limited success because of their vulnerability to environmental factors. Recovery buoy line-systems, which will be discussed later, also offer an attractive means of rescue by salvage.

There are a number of specific ways to improve these approaches and they all fall under the area of target enhancement. With regard to the submersible itself, a number of equipment combinations can be employed to this end.

Acoustic pingers or transponders which automatically actuate can be employed. Releasable radio or homing buoys are available. Strobe light systems are quite effective. With accessible but protected lift points salvage becomes less difficult. Appropriate color combinations improve visual location. Salvage fittings enhance recovery of the vehicle and may well increase the longevity of personnel trapped on board. If the submersible is lost on the surface a radio beacon, flashing beacon, flare gun, and dye markers may improve location potential.

The surface-support ship can also upgrade her search, rescue, and recovery capability. Acoustic ranging and side-look sonar systems are available to enhance location of her vehicle. Recovery line and winch equipment are mandatory. A droppable emergency 72-hr homing beacon provides back-up for the possibility that station keeping may become impossible. A standard 25-ton forged lift hook with 9000 ft of recovery plastic line will cover most lift contingencies.

In the area of general improvements the following capabilities should be considered. Increase in the life support system longevity to greater than 72 hr with thermal protection potential would allow on-board as well as outside help to respond favorably. If unmanned compartments can potentially flood, the ability to surface should not be compromised. Underwater frequencies, pingers, transponders, and sonar equipments should be standardized. Administratively an operations director should be responsible for planning and safety and develop qualifications and procedures. During deep dives all assets of the vehicle should be operational. Comprehensive dive plans should be developed which consider onsite resources available, outside resources available, outside resources within reach, and all cognizant organizations made aware of the planned operations. Operations in remote locations should be restricted. Formal briefing and debriefing sessions should be held to enhance safety and reliability of total vehicle systems. Operating manuals should be current and reflect status of the boats systems and modifications to those systems. Log keeping should be accurate and complete.

If rescue operations are initiated, single point control is mandatory. The area of rescue should be controlled and established as an independent piece of "rescuing authorities territory."

#### Innovation in Escape, Rescue, and Recovery

There are a number of innovative escape, rescue, and recovery concepts; some are on-line while others will require additional time, money, and testing. Even though individual escape has been made possible beyond continental shelf depths, the built-in limitations of these deep submergence vehicles would make incorporation of escape trunks with rapid compression capabilities impractical. Small, low-cost, unmanned vehicles offer an attractive alternative to another manned vehicle or other more expensive rescue systems. Through television, observation and inspection is possible. Additionally, as recently demonstrated they are capable of placing recovery lines. Self-deployed guideline systems exist and better ones are being developed which launch a messenger buoy with a guideline to enable a snap-on connector mate

with the downed vehicle. New attachment methods for salvage and rescue must be developed. These should include lift-line attachment devices, messenger line/buoy systems, a review of fastener technology, a variety of toggle designs, net-like capturing systems, and swimmer/divers with manipulators. Deep ocean gas lift systems are being developed and offer a possible solution to the potential or unwanted negative buoyancy. Explosive and pyrotechnic devices could provide a way to release a submersible from entanglement. If an emergency auxiliary life support/power pack could be married to the troubled boat, reduction of time for rescue constraints would be possible. This system would contain both power and supply of gas to support life for additional critical hours and days if possible. Fabrication of an oceanographic data package containing an integrated instrumentation system to measure a variety of environmental and physiological parameters is now possible and only awaits funding. Such a system would aid any form of rescue attempted from the surface or under the sea. The limitations of using divers for rescue have been discussed. Provision for a diver-operated work vehicle capable of supporting divers in water 1000 ft deep would enhance this now limited approach. Improvement in the existing diver stage/work platform could pay immediate return with capabilities that are now on-board.

#### Areas of Investigation

If group escape is selected as the most promising method, then transfer of personnel via another submersible or a modified personnel transfer capsule will be necessary. This approach will require extensive hatch compatibility studies to develop universal interfacing devices.

The feasibility and desirability of developing an on-call outside resource available for rescue of a downed noncombatant submersible should be reviewed. The three obvious groups to provide this service would be the U. S. Coast Guard nationally, the U. S. Navy, or private industry internationally.

Through the upgrading of present and the development of future escape, rescue, and recovery techniques as particularly described in the previous section, the safety of each international deep-submergence vehicle operation would surely be enhanced.

F. PROPOSAL FOR AN INTERNATIONAL INVENTORY OF UNDERSEA EQUIPMENT FOR USE  
IN RESPC USE TO UNDERSEA EMERGENCIES: H. TALKINGTON

A review of the operations for the rescue of the two submersibles JOHNSON SEA LINK and PISCES III indicated several features of submersible system design that were of particular importance in making possible their safe recovery. In addition to safety features of the submersible and surface-support equipment, two items of information proved to be of special importance: the detailed description of the distressed craft and the knowledge of the characteristics and location of equipment that could be called upon for emergency assistance. This paper recommends target-enhancement features and new equipment, and describes an inventory of currently available equipment and vehicles designed to fill these needs.

This effort was begun in 1973 when engineering personnel from Navy R&D Laboratories were directed by Captain Don Keach to form an ad hoc committee under the chairmanship of this author to make an assessment of equipment available for rescue, search, inspection, salvage/recovery, and surface-support operations. The results of the efforts of this committee are now documented in an inventory of Navy laboratory R&D equipment applicable to emergency undersea operations, which is available to U. S. Navy and Coast Guard units responsible for undersea search and rescue operations. (Refer to section entitled Inventory for further details of this available equipment).

Of significant assistance in the preparation of this inventory and of practical use to all concerned with submersible operations are two documents published by the Marine Technology Society: "Safety and Operational Guidelines for Undersea Vehicles, June 1968" and "Safety and Operational Guidelines for Undersea Vehicles, Book II, June 1974."

In addition to the inventoried R&D items, the ad hoc committee recommended features that would enhance potential targets for recovery and new equipment that would greatly increase the efficiency of undersea emergency operations.

Recommended Target Enhancement Features

The recommended features will significantly expedite emergency search and recovery operations of such high-value targets as the following:

Manned vehicles: submersibles; habitats.

Unmanned vehicles: work vehicles; instrumentation packages; weapons; aircraft; re-entry vehicles; ships; dumps.



Within these broad categories, features are considered as either mandatory or desirable to facilitate operations, as shown in Table IF-1. A brief discussion follows.

Table IF-1. Recommended target enhancement features for manned and unmanned targets

Use	Mandatory	Desirable
Manned and unmanned targets	Position indicator External standard lift points	Color
Manned targets only	Minimum life support Acoustic communications Minimum operator qualification Filing of dive plan with a potential rescue unit Passenger pre-dive briefing	Standardized salvage fittings Marker buoy Support ship recovery capability Description of submersibles

Position indicator--An acoustic beacon operating on a standard distress frequency placed on a manned target would automatically actuate whenever a critical depth was exceeded. For long range indication, a charge detonated in the sound channel would allow underwater listening systems to be used for preliminary location. In order to respond with rapid large-area search afforded by aircraft deployed and monitored sonobuoy sensors, it is recommended that the beacon operate on dual frequencies: 4 kHz for sonobuoy detection and 37 kHz for final approach.

External standard lift points--Clearly marked standardized lift points installed on all high-value targets would allow a distressed vehicle to be easily lifted to safety. An example of one possible configuration is shown in Figure IF-1. Here, two 8-in diameter rings are placed 90 degrees apart and fastened securely to strong points on the vehicle structure. Lift points should be strong enough to allow for total lift of the vehicle. Care must be taken to ensure that vehicle lift points are located to allow easy accessibility during rescue, but they should not protrude to the point that they would snag other objects during normal operations.

Minimum life support--Minimum life support items such as oxygen, air purifiers, heat, and adequate power should be established for each operating submersible, and a dive should not take place if a strict pre-dive check shows the submersible to be deficient. A minimum life support duration of between 24 to 72 hr, dependent upon local conditions of support is recommended.

Acoustic communications--A standard 8-11 kHz underwater telephone installed on all submersibles would allow for verbal communications between rescuers and rescuees.

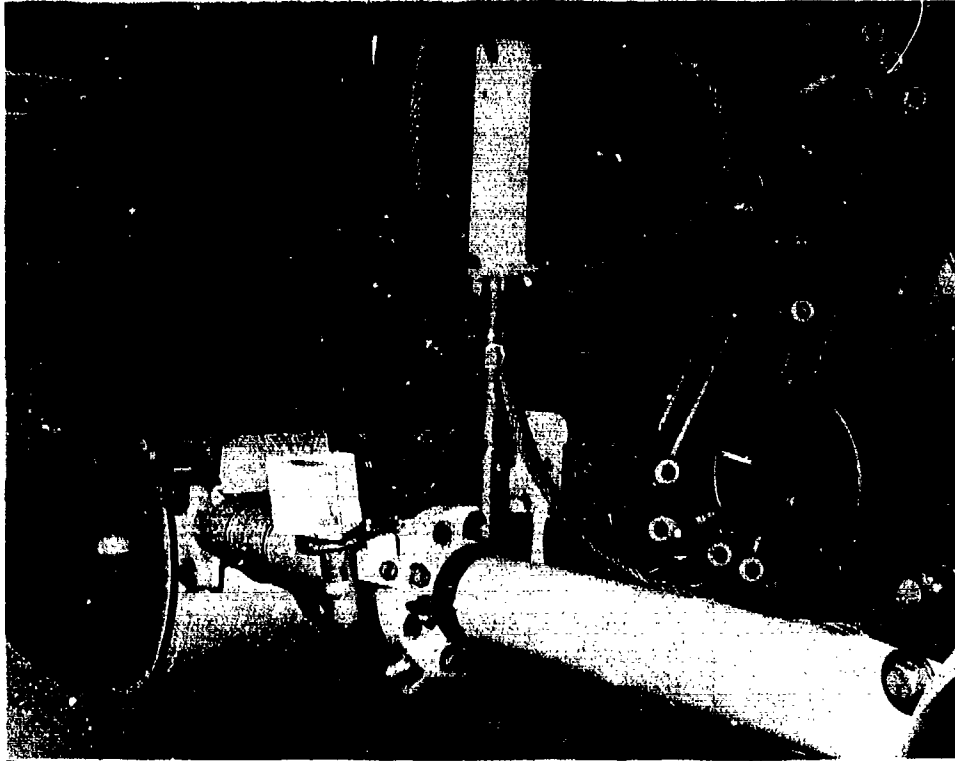

Fig. IF-1. Example of an external lift point, located on NUC's submersible MAKAKAI

Minimum operator qualification--Proficiency training for all submersible pilots--particularly emergency safety and survival procedures--and a program of periodic proficiency checks would give operators the confidence and knowledge needed in case of an emergency.

Filing of dive plan with a potential rescue unit--A comprehensive dive plan would enable the Coast Guard, U. S. Navy, or other rescue unit to maintain cognizance over all operations and devise realistic emergency contingency plans.

Passenger pre-dive briefing--A passenger on board a submersible should be thoroughly briefed on emergency and survival procedures prior to a dive in case the pilot should become incapacitated. Also, an emergency bill should be plainly posted inside the submersible to minimize reaction time.

Color--White and yellow are most readily seen under water. As a minimum, the target should be painted with easily identifiable checkerboard or other patterns in white or yellow. As a further aid, the use of reflecting materials is also recommended.

Standardized salvage fittings--An emergency, externally accessible, salvage fitting designed into all future manned submersibles would enable rescue personnel to provide quick help to the rescues in conjunction with more time-consuming rescue operations. If practical, such a fitting should also be backfitted into existing submersibles. This fitting, which must be designed and built to successfully qualify for extensive safety certification, should contain emergency air, communications, and power connections.

Marker buoy--A small automatic or crew-operated marker buoy installed on all submersibles could be used to mark the location of the stricken vessel as well as provide a light line to the surface which could act as a guide for lowering a heavier lifting line to the submersible. An example of such a buoy is shown in Figure IF-2.

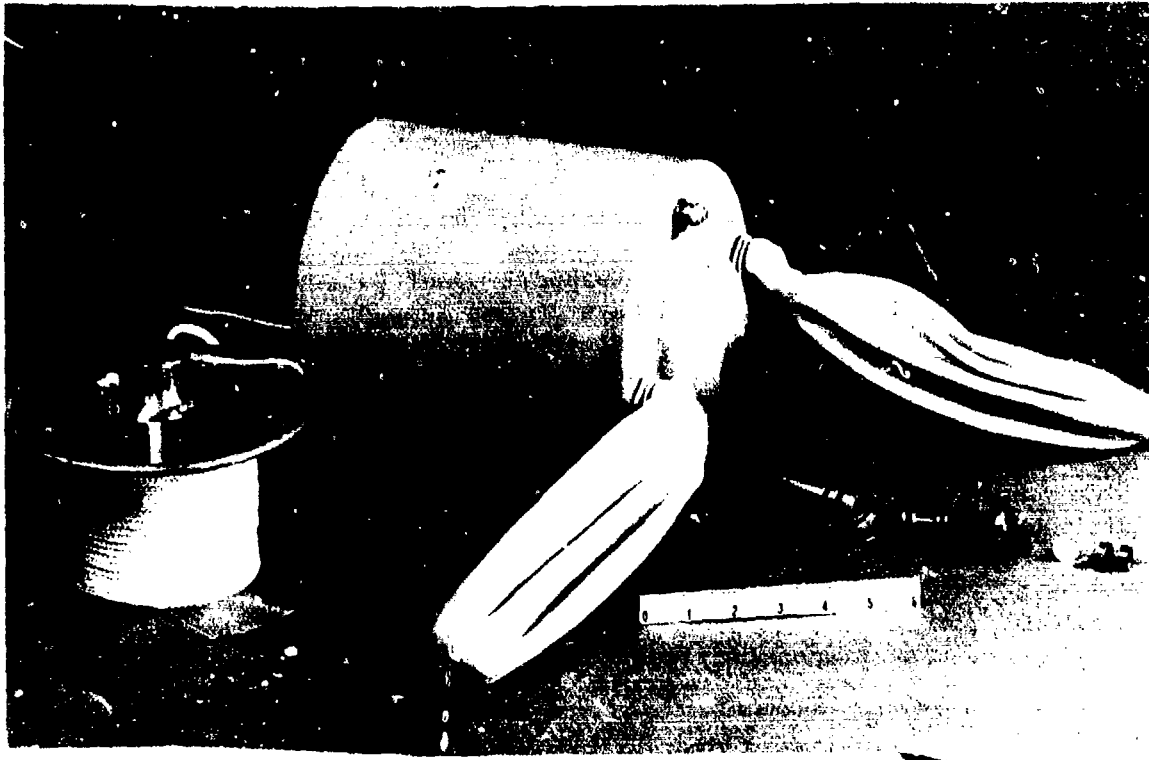

Fig. IF-2. Example of a small inflatable marker buoy and light line.

Support ship recovery capability--Since the submersible support ship immediately becomes the primary recovery vessel when a submersible accident occurs and remains so until outside assistance arrives, it must be equipped with at least a winch and line strong enough to haul the stricken submersible from its operating depth to the surface, and preferably strong enough to lift it on to the deck.

Further recommended is the prior development of a hazards analysis and compatible emergency plan that would anticipate each potential accident or would include provision for any special equipment needed on board both vessels, and would detail a plan of action for both the support ship and submersible crews. The analysis and plan take into account the operating environment the submersible may encounter during any given deployment.

Description of submersibles--A complete and up-to-date description of each submersible vehicle that includes drawings which depict hard points, description of rescue-salvage operations would significantly aid the rescue team.

## Recommended New Equipment

In addition to target enhancement features, certain new equipment is listed in Table IF-2. A brief discussion follows.

Table IF-2. List of recommended new equipment.

Crash position indicator (CPI) for submersibles
Small, low-cost unmanned vehicle
Protected diver stage
Expendable lighting
Diver-operated work vehicle
Emergency heat source
Emergency auxiliary life support/power packs for submersibles
Self-deployed guideline system for deep submersible rescue
Attachment methods for salvage and rescue
Explosives and pyrotechnics
Oceanographic data package

Crash position indicator (CPI) for submersibles--An acoustic CPI installed on submersibles (or other high-value targets) would allow them to be rapidly and accurately located. Design would accommodate transmission on sonobuoy acoustic frequencies (approximately 2 kHz) so that aircraft search could be employed for large area search (300 x 300 miles CEP). The CPI would also operate at higher acoustic frequencies (9.37 and 45 kHz) for final location purposes.

Small, low-cost unmanned vehicle--A small tethered vehicle is proposed as a safety backup system for manned submersible operations and general purpose inspection tasks. Such a vehicle could provide a real time television observation of rescue operations and could place recovery tag lines to the stricken vessel at depths to 1500 ft and on currents to 2 knots. An onboard movie or still camera would allow photographic documentation of the operations.

Protected diver stage--A protected diver stage that would act as a work platform would increase the versatility and capability of the diver during rescue operations. This platform would also protect the diver from mechanical hazards and sea life. The diver should be able to control the buoyancy (lifting/lowering) of the stage/working platform, which should have a backup surface-mounted tether. When removed from the rigid surface cable, the stage would not be subject to ship motion; this would facilitate the work of the diver. The stage should have an emergency surfacing capability with a design concept that would ensure surface flotation and enable a diver inside to get his head out of the water without leaving the protection of the cage. The tether from the ship should include, along with the lifting line, a power cable for lights, communication system, etc., as well as hot water (when required) for a thermal suit. An anchoring device should be incorporated to enable the diver to anchor his positively buoyant stage/working platform any desired distance off the bottom. This anchoring system should be releasable in an emergency and should be strong enough to hold the stage firmly,

thus reducing the effect of currents and surface action.

Expendable lighting--Expendable lighting sources would prevent unnecessary vehicle battery drain and provide long-range wide-angle viewing contrast.

Diver-operated work vehicle--Since there are at present no provisions for surface support of tools, placement of equipment, movement of heavy loads, or transport of divers and equipment, only those jobs which can be accomplished through the manual efforts of the diver can be performed. A diver-operated work vehicle could provide a total work-support system operational to depths of 1000 ft. The design, fabrication, and test of such a vehicle would be preceded by a study of emergency mission requirements to ensure compatibility of the diver system with emergency search and rescue operations.

Emergency heat source--Successful rescue of entrapped personnel from stricken submersibles and diving capsules in cold water has in the past been hampered by lack of heat sources to maintain minimal body temperatures. The technology for developing self-contained, compact, and reliable undersea heat sources that use the exothermic reaction of magnesium with seawater has been developed. The design, fabrication, and evaluation of a self-contained portable emergency heat source capable of maintaining a suitable life support environment in submersibles and personnel transfer capsules should be preceded by a study of heat requirements and rescue mission profiles.

Emergency auxiliary life support power packs for submersibles--in many cases, recovery/rescue operations for trapped submersibles could be significantly improved if temporary additional life support and power were attached to the distressed submersible. This would provide more time and greater control of the situation by reducing time constraints and attendant panic, hasty judgment, and waste. A proposed pack would consist of the power/gas supply and equipment for underwater connection to the submersible.

Attachment methods for salvage and rescue--Once a downed submersible has been located, it is imperative that a lift line be expeditiously attached to it. Currently available attachment systems are not adequate to handle many foreseeable eventualities. Many promising attachment systems are currently in use in undersea oil and mineral industries, space, and navy systems. A review and evaluation of these should yield designs that could be used by divers with either manned or unmanned vehicles.

Explosives and pyrotechnics--A downed submersible that has become entangled in foreign material may need to be cut loose by use of explosives and pyrotechnics such as Pyronol. Such technology needs to be developed.

Oceanographic data package--An integrated instrumentation system which would measure, record, and display environmental parameters is essential to plan and conduct rescue, salvage, or emplacement of objects on the ocean floor to depths of 20,000 ft.

Table IF-3. Emergency R&D support inventory outline

---

Name of Item

Owner/Operator

List address(es)

Description

Photograph or line drawing

Capability (operating depth, speed, endurance, etc.)

Limitations

Physical dimensions

System composition (to provide system capability)

Applicability

Search, inspection, recovery, etc.

Operator/Crew Requirements

Support Ship Requirements

Station-keeping, deck space, power, etc.

Aircraft Loading Requirements

(If applicable)

Single Point of Contact and Alternate

Include addresses and phone numbers (for 24-hr response)

Homebase

Status

Mobilization time

Location

Operability

Condition

Additional Information

## Inventory

The type of equipment recommended in this report for use with both submersibles and surface-support craft are of significance because they will not only enable the submersible operators themselves to assist in rescue operations but will also enhance and supplement the currently available inventory of navy laboratory R&D equipment. The objective of the current inventory is to provide a concise and succinct, yet thorough, listing of Navy R&D equipment that could be available for response to an undersea emergency involving submersibles or other high-value targets.

This inventory lists some 91 items submitted by navy laboratory community members in response to an emergency R&D support inventory outline, as shown in Table IF-3. Available items are grouped into 11 sections by primary function, which establishes the taxonomy of the inventory: surface support ships, undersea vehicles, anchors/moorings, buoyancy items, lifting equipment, instrumentation, power sources, undersea navigation, surface navigation, divers' equipment, air support systems.

The inventory is indexed by Homebase, Mission (search, inspection, salvage/recovery, rescue and surface support) and Depth Capability of each item. The Naval Undersea Center is responsible for the annual updating of laboratory copies of the inventory and for bi-weekly updating of similar inventories (known as Dynamic Inventories) which are kept at the primary navy-user offices: The Supervisor of Salvage, Naval Sea Systems Command, Washington, D. C., and Submarine Development Group One Headquarters, Fleet Station Post Office, San Diego, Ca. A third primary user is the Deep Submergency Office, Office of the Chief of Naval Operations, Washington, D.C. These three units have the authority to call out Navy resources in emergencies. Any organization with an emergency need that could benefit from these resources should contact one of the above offices.

## Conclusions

Target enhancement features and new equipment for use in undersea emergency rescue have been defined and discussed. Of primary significance in the types of equipment recommended for use with both submersibles and surface-support craft is that they will enable the submersible operators themselves to assist in rescue operations. It is recommended that contingency plans and operational procedures be developed that, along with the recommended items, will better prepare for distress situations. It is concluded that adoption of the recommended items will minimize current risks to submersible craft and, of even greater importance, assist the submersible occupants and the surface-support crew in their response to undersea emergency situations.

## SUMMARY OF DISCUSSION

A point was made regarding scientific budget cuts and the need to work with smaller ships and crews. This situation leads to multiple jobs for the operators and potentiates personnel fatigue. It was indicated that while the batteries do run out first in a 1-day mission, after a 3-day mission the pilot and crew members can quite often end up with less than 6 hr total sleep. Decision making, especially for the pilot, would probably be altered. Two things must be considered; one is training and reliability of the pilot himself to be able to realize the point at which he should no longer be diving and the other is honesty within the organization to say they've had it and that they are not going to dive any more.

About 5 years ago, while Westinghouse was operating Deep Star 4000, they normally had dives of about 6 hr which were a compromise between battery power and scientists' duration at the viewport. There were some dives longer and some shorter. They became interested in how long an operator could retain his proficiency, so they ran a 24 hr test dive with an observer from their central research laboratory taking data on two pilots and performing some elementary tests about every half hour. These kinds of tests should be conducted. It appears that for any single occurrence, the excitement of the occasion overcame the crew's fatigue factor. The crew was keyed up when they were down a couple of thousand feet and cruising around the bottom, taking readings. A 24-hr dive was entirely possible with no visible loss of proficiency on a one-time basis. How soon they could repeat that mission is not clear.

It is important to know how fatigue contributes to underwater accidents, not just in submarine operations but in commercial diving activities as well. We underestimate its effects. Fatigue appeared to enter into the U. S. Navy's SEA LAB problems as well as other stresses.

Commander Submarine Development Group One has begun to look at operators during current routine dives in terms of what they are doing and to ascertain whether or not they are having any biological problems. At present, it is simply a matter of meticulous intake, output, and weight-change measurements with routine urinalysis to measure specific gravity and to look for the development of a ketonuria as an index of catabolism. Also, they are beginning to correlate information as to whether or not there is any commonality in an operator's ability to perform as related to his background, training, and psychological make up. If he mistakes during the operation, it is recorded in the log and the mistake is correlated. This study is just beginning and they plan to take a look at all of their vehicle operations. They may even go into other types of stress indicators such as uric acid levels, eosinophile counts, cortisone excretion and others.

The question was raised as to any research that has been done to determine the best work/rest schedule for personnel in this kind of a situation. What



is the best way to distribute work, rest, and sleep in order to maintain effective operator performance under conditions in which physical space and exercise are severely limited? The tasks although critical are often monotonous and boring. So far this has not been a problem for DSVs because the missions have usually lasted only a few hours; 6 - 8 hr seems to be the maximum mission length. Problems may arise, however, if fuel sources and life support facilities are developed which extend DSV missions beyond this present maximum. Research at Commander Submarine Development Group One under conditions similar to those experienced by DSV operators shows that fatigue begins to impair diver performance after 6 hr of light work. These divers were involved in O<sub>2</sub> breathing experiment which required periodic physiological and psychological testing. The divers were confined to a crowded chamber, were not permitted to exercise, and had to follow a monotonous research protocol. After 6 hr of this procedure, motor and cognitive performance began to deteriorate and continued to do so until the dives were ended 10 to 15 hr later. The divers found it extremely difficult to rest or sleep under these conditions, although they denied being fatigued until near the end of the dive. They did report being less active and less satisfied and these reports were interpreted as being indirect signs of fatigue. The impairments in motor and cognitive performance, however, preceded these other reported effects by several hours, indicating that performance may become significantly impaired long before fatigue is recognized. It is likely that DSV operators could suffer similar effects if missions are extended much beyond present maximums and procedures are not developed to avoid or minimize fatigue. It is certainly imperative to monitor performance using a standardized procedure in order to detect fatigue before it reaches critical, conscious levels.

Fire is not a minor consideration, but currently, there are not even ways of monitoring some of the critical contaminants. Most atmosphere-monitoring system devices are fairly significant in size, although there are numerous parameters that can be tested with portable units.

A recent NRL progress report ("Fire Suppression in Submarines" May 1974), shows that nitrogen pressurization of a closed-cabin environment holds considerable promise as a solution to the submariner's fire-suppression problem. In addition to knocking down the flames, it quells the gross production of noxious gases and, if deployed quickly enough, leaves a habitable postfire atmosphere which could easily be returned to normal without surfacing. The oxygen partial pressure can be maintained at a comfortable 0.20 atm. The final pressure after the nitrogen was added approached 1.4 atm. In these studies the nitrogen oxides were less than 2 ppm by volume.

With the attention that most people are giving to internal materials for submersibles, the likelihood of fire is relatively small. In some cases one needs a piece of scientific instrumentation but it has all the wrong materials in it. If you are forced to take the device it must be recognized as a hazard and it should not be placed next to the life support oxygen input. The question is not so much one of eliminating all hazards--that is virtually impossible--but recognizing those that are present and minimizing those that are beyond the acceptable limit.

In a saturation diving situation where one is operating with as high as 0.4 oxygen, there is encroachment on the fire zone. One might be covered with volatile fuel upon return to the lock-out portion of the submersible. This situation may contraindicate saturation diving, unless there is a way of getting rid of the bulk of the clothing, or whatever the diver is wearing which may contain these contaminants.

The question of whether Halon 1301 was toxic or not in a hyperbaric situation and what the limits were was raised. Information in animals is available but is questionable. Increased pressures give Halon 1301 somewhat of an anesthetic characteristic and it may be potentially harmful. These studies were conducted at quite high pressures, out of the physiological range, but it does imply that there might be a harmful effect. It looks like a very desirable agent because of its ability to stop fires at their source.

The U. S. Coast Guard indicated that rescue system budget items introduced to the Office of Management and Budget have been cut. They feel that until considerably more off-shore activity occurs, such as is happening in the North Sea, the U. S. Government will not be going into the rescue business. They believe that the unmanned vehicle concept is the best way to go and feel that a 3000-ft capability would be sufficient for the next few years. They believe that deeper boats like ALVIN are super-safe and are pretty much on their own in a rescue sense, but that smaller, shallower boats have been built with less safety and it may be sensible to provide them a universal rescue system.

A novel and unusual concept has been proposed by Hans Kylstra, at Duke University, for escape in deep-diving boats; that is, breath-hold liquid breathing lock-out. It appears to be physiologically conceivable that one could fill the lungs to residual volume with a tolerable saline solution. Then, by having a floodable compartment for instant pressurization of a small residual space, one could force enough oxygen into the saline for possibly a 15 or 20 min breath-hold dive and, therefore, an ascent to the surface from considerable depth. Desalination and lung re-expansion facilities would have to be available. Decompression requirements would be nil and survival from quite deep escapes might be possible.

It was pointed out that in an emergency situation the duration of a CO<sub>2</sub> canister might be increased by the following method:

- a. hold the "used" CO<sub>2</sub> canister in your hand,
- b. inhale cabin atmosphere,
- c. put mouth to CO<sub>2</sub> canister and exhale with a steady flow to force the expired air through the chemical bed.

The following items affect efficiency of a CO<sub>2</sub> canister:

- a. the high CO<sub>2</sub> content in the expired air;
- b. the low CO<sub>2</sub> canister face velocity of the expired gas increases the residence time;
- c. the CO<sub>2</sub> canister will have a constant high inlet-air temperature, regardless of the cabin atmospheric temperature.

Lockheed Missiles and Space Company has developed an O<sub>2</sub> supply and CO<sub>2</sub>-removal emergency breathing system which uses potassium superoxide. This self-sufficient system does not need power. It may be used either in closed- or open-loop operations. The rechargeable canister has a 48-man-hour capacity with a size of 1" diameter by 12" long. The unit is now ready for ABS certification but is very vulnerable with increased humidity or water vapor tensions.

Trace-contaminants analysis for long-duration emergency stays were discussed. It was recommended, in addition to adequate O<sub>2</sub> supply and CO<sub>2</sub> removal for prolonged submersible operations, that the trace-contaminant levels in the submersible be tested and analyzed. With the low volume per man ratio and/or an inadequate waste-management system, some trace-contaminants may exceed their Emergency Exposure Units affecting the crew's activity and mental acuity, or may even be lethal. Special attention should be paid to CO concentration, since CO will not be effectively removed by charcoal, LIOH, or other CO<sub>2</sub> removal chemicals.

The question was raised as to studies which have been conducted relative to levels of CO during small submersible operations. Indications were that for 8 - 12 hr CO would probably be no problem, but in a lock-out and/or a saturated mode, this could be a problem area. In a multiday experience such as the PISCES incident, CO may also present difficulties. If the present life support systems are to extend mission times, CO must be handled. Vickers commented that they have detected elevated CO levels even on short dives. It is well-known that smokers in a sealed cabin will outgas CO. Also RBC metabolism will contribute CO to the closed environment at the rate of 4 cc's a day per man.

In a 13-hr, 13-man test in one sphere of the DSRV, the CO level was elevated to 42 ppm in about 6 hr. The volume of the sphere was 3200 ft<sup>3</sup>. For 12 hr a 100 ppm of CO is acceptable.

Another problem associated with longer dive missions is waste elimination. If not handled properly, accumulation of toxic gases could degrade the environment.

Hydrocarbon contamination from a diver returning from an oil producing well-head would seem to interfere with the class A clean environment required in hyperbaric situations related to lock-out submersible operations. With the variety of volatile and nonvolatile hydrocarbons a diver could bring back to the submersible, oxygen make-up gas input and elevated O<sub>2</sub> levels for decompression could be hazardous. This is a problem which has been experienced with lock-out divers involved in aircraft salvage. In addition to the immediate hazard, it requires considerable submersible decontamination following the dive. The same problem is faced with PTC diving operations.

The new, 1-atm, nitrogen-purged well-head environments were discussed. Because of the risk of hydrocarbon leakage and the fire hazard, these closed cabins are purged with nitrogen. Workers move about wearing "hookah" rigs and emergency backpacks. This is a very difficult and dangerous situation if one should lose a mask and breathe 100% N<sub>2</sub>.

As a result of the SEALAB project and subsequent work conducted at the Research Institute, it became evident that at 1000 ft the thermal loss, at moderate work rates was in excess of 1000 watts. This thermal loss could not be effectively replaced externally, so heating the diver's gas supply was indicated. Minimum inhalation-gas temperatures at a variety of depths have been determined to allow safe diving operations. This information is available from an Experimental Diving Unit report.

The Navy, in cooperation with the AEC, developed a nuclear-reactor type of heater for the SEALAB Project. The heat exchanger worked remarkably well and it appeared to be cost effective. But the heat delivery system was not functional. This should be investigated again.

For many years NASA has been using fuel cells satisfying energy requirements. These devices appear to offer some hope for our problems but require considerable engineering modification to be adapted for use in submersibles.

The Defence and Civil Institute of Environmental Medicine, in Downsview, Ontario, has developed a computer program for the analysis of data on a cold diver. They are working towards being able to predict, at particular depths, what energy requirements will have to be supplied to both forward- and diving-compartment environments. It appears, at this time, that they favor a chemical method developed by the French, combined with supplemental electrical heating. Use of this system was scheduled to begin in March of 1975. Essentially it is a diver-carried package that provides 6 hr heat in cold water utilizing a salt heat-exchange system. The next step in the evaluation is to design a chemical heating system that could be put on the submersible itself. This would heat the atmosphere and the diver as well.

## CONCLUSIONS AND RECOMMENDATIONS

1. There is a major and expanding future for manned submersibles.
2. There will be increasing use of the unmanned systems in the complimentary spectrum of capability from diver to deep submersible.
3. A dramatic increase in the small, highly transportable boats in support of industrial work in the oceans will be seen. The majority of them will have about a 4000-ft capability, which will match the offshore oil industry's projection of maximum drilling depth (for producing wells) by 1985.
4. There will continue to be development of the hybrid submersibles which have diver lock-out capabilities, and which may carry their own unmanned submersibles on board for hazardous situations where a diver or manned vehicle cannot get close to the site of interest.
5. The major forcing function in world wide development of submersible systems will be the energy crisis and the need to explore and develop ocean resources of petroleum as quickly and efficiently as possible.
6. Small submersible operations are limited by the following factors:
  - a. Power requirements
  - b. Launch and recovery capabilities
  - c. Personnel fatigue
  - d. Life support systems
  - e. Communications
  - f. Closed-cabin hazards (fire, toxic wastes and materials)
  - g. Escape, rescue, and recovery potential
  - h. Certification or classification constraints
  - i. Personnel training requirements
7. Investigate new types of power packages such as fuels cells and closed-cycle brake turbine devices which utilize carbon blocks or liquid salt to store heat.
8. Develop the semi-submerged ship concept coupled with an elevator device to solve the launch and recovery problem.
9. Personnel fatigue and performance studies in these submersibles, under the actual conditions of confined space, high and low temperatures, and extreme humidities should be conducted. Procedures should be developed to avoid or minimize fatigue in expected longer missions.

10. Life support potential to last 1 week must be provided for a submersible. The ability to decrease one's metabolic rate once escape becomes impossible and rescue efforts begin might increase life support endurance significantly.

11. Even though fire has not been a significant problem in recent history of vehicle operation, the recent NRL fire research program utilizing nitrogen suppression should be considered as an answer to this potential problem.

12. Each submersible incident is unique, thus a variety of various capabilities including other submersibles, both manned and unmanned, together with divers, and "diving-bells" may be necessary to provide the rescue potential needed to perform offshore rescue/recoveries.

13. Because of the limitations of outside resources, organizations employing submersibles may have to rely entirely on their own resources in the event of an underwater accident. However, the records to date indicate that such is not the case. Of all the major accidents to date, salvage and a successful recovery has required outside resources of considerable magnitude.

14. Of the three approaches available to recover personnel from the bottom, the most sensible at this time appears to be rescue by salvage.

15. There are a number of innovative escape, rescue, and recovery concepts; some on line while others will require additional time, money, and testing.

a. Small, relatively low-cost, unmanned vehicles offer an attractive alternative to another manned vehicle or other more expensive rescue systems.

16. If group escape is selected as the primary method of rescue, extensive hatch compatibility studies are needed to develop universal interfacing devices.

17. The feasibility and desirability of developing an on-call outside resource available for rescue of a downed non-combatant submersible should be reviewed.

18. An international inventory of undersea equipment for use in response to undersea emergencies should be developed.

## SESSION II: SUBMERSIBLE INCIDENTS

### A. ANALYSIS OF U. S. SUBMERSIBLE ACCIDENTS: J. A. PRITZLAFF<sup>1</sup>

This discussion reviews some accidents and incidents in order that future submersible operations might benefit from prior experience. Incidents are classified as related to handling and rigging, operations, or equipment. It is not the purpose of this paper to pass judgment on any activity or actions by companies or individuals and events and personal conclusions related here have no legal foundation.

#### Handling and Rigging Incidents

##### Incident No. 1: Loss of the submersible ALVIN.

Description--The first major incident in the small submersible field took place 16 October 1968 when the ALVIN was dropped, with personnel aboard and the pressure-hull hatch open, into the sea during launching. The pilot, standing in the sail, got clear and the two occupants escaped as the vessel began to fill with water. Flooding resulted in the loss of the vehicle 135 mi southeast of Woods Hole, Mass., in 5052 ft of water. (ALVIN was recovered by ALUMINAUT 28 August 1969, with the aid of photographs taken from USNS MIZAR.)

Cause--ALVIN's loss came about through failure of the support ship launching equipment. The primary cause of the incident was the failure of the elevator platform cable. Unfortunately, the cable run was such that the cable flexed over a sheave in an area that was not accessible for inspection and maintenance. A secondary cause of the loss of the vehicle was the procedure that called for lowering the vehicle with its hatch open.

Corrective action--The support ship LULU has been extensively rebuilt with the elevator-cable system being replaced with a link-chain system. The chain is able to bend around the hoisting sheaves without experiencing the wire fatigue that contributed to the original failure. Operating procedures have also been changed so that the vehicle is lowered from the deck level to the water unmanned and with the hatch closed. The pilot and crew then board the vehicle and proceed on the mission.

Summary--ALVIN's loss was caused by a failure in the handling system and subsequent flooding of the pressure hull. The fact that ALVIN was a submersible did not directly enter into the cause of its correction.

<sup>1</sup>This paper is condensed from "Submersible safety through accident analysis," by J. A. Pritzlaff, Marine Technology Society Journal, May 1972.

Incident No. 2: Loss of the submersible NEKTON BETA.

Description--On 21 September 1970 NEKTON BETA was working with NEKTON ALPHA on the recovery of a 24 ft motor boat. The recovery site was some 500 yards off Jewfish Point, Santa Catalina Island, California, with a bottom depth of 230 ft.

The two submersibles attached a lifting line from the surface support ship M/V OIL CITY, to an existing line on the motor boat that ran from its bow mooring bit out through a bow fairlead and down to an eye on the stem. Several other miscellaneous lines on the motor boat were also attached to the lifting hook.

As the lift of the motor boat started, NEKTON BETA and NEKTON ALPHA made plans to surface. NEKTON BETA elected to remain submerged so as not to add to the confusion on the surface relating to recovery of the motor boat. The lines on the motor boat parted at about 50 ft and the boat fell back through the water. In doing so, it struck NEKTON BETA, breaking a 3 x 6 in. section out of one of the port conning-tower viewports. NEKTON BETA flooded and sank. The pilot, R. A. Slater, was fortunate in making an ascent to surface. The observer, L. A. Headlee, lost his life. NEKTON BETA was recovered 28 September 1970 through the efforts of NEKTON ALPHA and the M/V OIL CITY.

Cause--The loss of the vehicle was due to two related events: the failure of the motor boat lines that were used as part of the recovery system and the situation that permitted NEKTON BETA to be below the hoisted load.

Corrective action--In general, a basic premise would be "Do not get below a load that is being lifted." The dropping of the motor boat appears to be the result of the failure of the lines that were attached to the boat or their attachment fittings or the direction of the applied load as placed upon the lines and/or fittings. Rigging gear should be tested for adequacy under the loads to be applied. If the contingencies of recovery make this impractical, then appropriate alternate action should be taken.

Summary--The loss of NEKTON BETA was due to failure of rigging equipment and a procedural situation relating to hoisting loads and position of observers. Neither of these related events are directly associated with submersible activity.

Incident No. 3: Dropping of DEEPSTAR 4000.

Description--In May 1967, DEEPSTAR 4000 was undergoing a series of test dives at Panama City, Florida. During a launch cycle, the vehicle was hoisted off the deck of the support ship M/V SEARCH TIDE and swung over the side. While some 5 ft in the air, the quick-release launching hook unexpectedly opened and dropped the vehicle into the water.

The DEEPSTAR 4000 landing system consisted of a stern-mounted 25-ton back-hoe type crane. The articulated end section of the boom is fitted with a hydraulically retracted wire pendent and a helicopter-type quick-release hook



assembly. Normal launch operation calls for embarking the pilot and two observers while the vehicle is secured on deck. The crane hook is then attached and the vehicle is hoisted clear of the deck. The crane then rotates 180°, extends the wire pendent (about 3 ft), and lowers the vehicle until it is awash. The release hook line is pulled and the vehicle is uncoupled from the crane and held by a light "tag" line while the pre-dive checklist is completed. A swimmer then releases the tag line when the pilot gives the ok-to-dive signal. The release hook had been successfully used over many dives and its operation had always been precise and positive.

Cause--The events surrounding the unexpected release were examined; as far as could be determined, the release line was not fouled nor had it been accidentally pulled. Examination of the hook showed that under certain conditions, a mechanical open/closed indicator could point to closed when, in fact, the hook was only partially latched. It was concluded that the visual check of the hook showed a "closed" hook and the OK to launch was given. The hook in fact was partially closed. It held the vehicle load (18,000 lb) for the lift and 180° swing but the stop-rotate motion of the crane was enough to open the hook and drop the vehicle. The crew was shaken up and some vehicle damage was noticeable. A complete disassembly and inspection of the vehicle was necessary to establish the extent of damage to the vehicle.

Corrective action--Two sequential actions were taken to prevent a recurrence of this drop incident. First, the hook was modified internally, so that the open/closed indicator was positive and true in its indication. Second, a different type of release hook was obtained that would not release until the load was down 500 lb. Using this hook, the vehicle had to be on deck or afloat before the hook could be triggered to open.

Summary--Premature opening of a launching release hook dropped DEEPSTAR 4000 into the water from a height of about 5 ft. The incident was not related to the submersible aspect of the operation.

Incident No. 4: Storm damage to BEN FRANKLIN.

Description-- BEN FRANKLIN was operating in the Bahamas. It was towed from dive site to dive site by the support ship PRIVATEER (a converted YMS). At night while the PRIVATEER was at anchor, with the BEN FRANKLIN moored astern, a sudden storm came up. The combined drag of PRIVATEER and BEN FRANKLIN caused a failure in the anchor system and both vessels were forced onto a reef. The submersible, having minimal surface propulsion capability, was damaged in the keel and battery pod areas. Privateer was finally able to maneuver herself and BEN FRANKLIN clear of the reef.

Cause--A failure in the anchoring system (i.e., poor holding bottom/or overload anchor) resulted from the combined drag of the two surface vessels.

Corrective action--While at sea, storm conditions can rarely be duplicated. It is conjectured that additional or stronger anchoring systems would be used for future operations.

Summary--The grounding of BEN FRANKLIN was caused by the failure of a surface

ship anchoring system. The submersible aspect of the operation did not enter into the cause of the incident.

Incident No. 5: BEAVER Launching Accident.

BEAVER (ROUGHNECK) was damaged during March 1969 while being launched from her marine railway landing facility on Catalina Island.

Description--For sea trial and nearshore operational work, BEAVER utilizes a marine railway-type launch system. The vehicle sits in a cradle and is run down a track into the water. Under rough water conditions, this system has problems when the vehicle is becoming buoyant on the cradle. Recovery is particularly difficult under these conditions, as the floating, bobbing vehicle must be brought into contact with the rigid cradle.

Cause--The "system" concept of this launch/recovery equipment did not allow for the rough water that was actually encountered.

Corrective action--Launching the vehicle in a "heavy" trim condition would improve passage through the air/sea interface. Once beneath the surface, and at an appropriate depth, the vehicle could be released, gain neutral buoyancy, and start her mission. Recovery could also be done underwater with the vehicle coming into the area under neutral trim conditions. It could be hooked onto a winch cable and then pulled down onto the cradle. Ballast water would be pumped in until an appropriate heavy condition is achieved for passage out of the water on the marine railway.

Summary-- The marine railway-type launch and recovery system was not appropriate to heavy-sea operations. The submersible aspect of the vehicle did not contribute to the problem and might even assist in its solution.

Incident No. 6: Near-loss of GUPPY.

Description--GUPPY was on deck after a dive. The hatch was open and the hoisting winch cable was still loosely attached. A sudden sea swell caused the support ship to roll unexpectedly and GUPPY slid along the deck until stopped by the winch cable. If the cable had not been attached the vehicle would probably have gone over the side with her hatch open and been lost.

Cause--The vehicle was not lashed down on deck. The open hatch could have been a problem if the vehicle had gone overboard.

Corrective action--The operating team established a new procedure such that: "GUPPY's hatch must not be opened after or between operations until the vehicle is lashed down."

Summary--The deck handling of the vehicle created the incident and it was not related to the submersible aspect of the operation.

Operational Incidents

Incident No. 1: Collision of ASHERA.

Description--While operating in the Aegean Sea during the summer of 1964, ASHERA struck an underwater object and cracked a viewport. No flooding resulted.

Cause--The vehicle was operating in a depth region where subsea wave action was present. There were no guards on the viewports and no vehicle structure in front of the pressure hull.

Corrective action--External guards were installed in front of the viewports.

Incident No. 2: Loss of contact with surface ship of SEA CLIFF and TURTLE.

Description--While undergoing sea trials in the Tongue of the Ocean off of New Providence Island, the AUTEK vehicles (SEA CLIFF and TURTLE) became separated from their surface support ship.

Cause-- Subsurface currents were not considered in the operational plans. These subsurface currents in the operating area unexpectedly moved the vehicle(s) away from the surface ship where vehicle communications contact could be lost.

Corrective action--Subsurface currents were measured in the operating depth region and operational plans were made that accounted for vehicle drift within the current pattern.

Incident No. 3: Loss of contact with surface ship of DEEPSTAR 4000.

Description--While operating at night in the Gulf of Mexico off of the Florida coast, DEEPSTAR 4000 became separated from her surface support ship and lost communications contact. After surfacing, DEEPSTAR 4000 could not establish surface communications and was temporarily lost. She was located and recovered by the support ship after the submersible pilot fired a small signal flare.

Cause--The vehicle was diving in the vicinity of the Gulf stream, and the subsurface-current profile did not follow the surface-current profile. This resulted in the loss of underwater communications. Using established "loss of communications" procedures, the vehicle surfaced. An electrical storm affected the small "CB" radio and surface communications could not be established.

Corrective action--Greater emphasis was placed on subsurface-current profiles as well as the tracking system trends with respect to drift. The submersible "CB" radio was replaced with a higher power FM system and an FM direction-finding capability was added to the support ship. The submersible flare system was upgraded to a 20 mm size with a parachute-flare capability.

Incident No. 4: Loss of depth control by ALUMINAUT.

Description--While on sea trials in Long Island Sound, the ALUMINAUT lost depth control and made a rapid unexpected excursion toward the bottom. Immediate corrective action prevented bottom contact.

Cause--The operational area crossed the offshore mouth of the Connecticut

River. The submersible being trimmed for salt water became heavy as she entered the fresh water river flow. With a 70-ton submersible, the change in buoyancy was 3500 lb on a calculated basis.

Corrective action--Immediate action was to blow ballast tanks, drop shot, and power up with the vertical prop. A diver took water samples that showed fresh water down to 120 ft. The operating area was then shifted to avoid the offshore effect of the river.

Incident No. 5: Hazard of moving marker lines.

Description--While operating on oil pipe line and other bottom surveys, the Perry submarine group used anchored lines as markers and reference points. The lines tended to float up and/or move into the path of the survey sub, creating a hazardous situation.

Cause--The marker lines were near neutral in buoyancy and moved around in the water.

Corrective action--Leaded (or lead-filled) lines were used as reference markers. These stayed put on the bottom and did not endanger the submersible.

Incident No. 6: Entanglement of DEEP QUEST in line.

Description--While conducting a recovery test in 430 ft of water, DEEP QUEST became entangled with a 3/8 in. polypropylene line. The line was caught in the port prop assembly of the vehicle and effectively anchored the submersible to the test object.

Cause--The test object was placed using the polypropylene line with sections being cut rather than removed.

Corrective action--The submersible NEKTON was transported to the scene and, using a divers knife attached to her manipulator, cut DEEP QUEST free. A review of the operating conditions will be made prior to entry into the area. Specific problems such as lines will be identified and considered during vehicle movements.

Incident No. 7: Dropping of battery by DEEPSTAR 2000.

Description--During a rough water launch, DEEPSTAR 2000 unexpectedly dropped a battery. The batteries form part of the vehicle's safety system and can be dropped using a manual cable-release system. The cable runs from the manual crank on the pressure hull through the exostructure to the battery box.

Cause--Flexing of the exostructure during the rough water launch was sufficient to trip the release mechanism and drop the battery.

Corrective action--The exostructure was stiffened in those areas where interaction with the battery drop cable was significant.

## Equipment Incidents

### Incident No. 1: Flooding of GUPPY's motor.

Description--While operating in the Bahamas off Freeport, GUPPY experienced flooding in a propulsion motor resulting in a massive electrical short circuit to the 440 VAC supply (cable power from the surface).

Cause--The power connector at the motor had two seating surfaces that were to seal when the connector was properly attached. Investigation of the flooding showed a dimensional error of 0.012 inch such that the connector looked seated but in reality was not.

Corrective action--The design of the connector was changed such that only one seating surface is required.

### Incident No. 2: Power loss of ROUGHNECK (BEAVER MK IV).

Description--During June 1970 off of Santa Barbara, ROUGHNECK (BEAVER MK IV) experienced a propulsion system short circuit and lost power to the starboard propulsion motor. Port and starboard trim was affected and some arcing and smoking occurred inside the pressure hull.

Cause--A short circuit in a junction box had burned a hole in the starboard propulsion cable. The oil-compensating system for the junction box had tried to account for the loss of oil in the box; this resulted in the loss of the compensating oil which affected the vehicle trim.

Corrective action--Following the incident, clean-up repairs were made. Salt water/electrical system interactions are always possible and secondary failures can be eliminated through system isolation and redundant safety features.

### Incident No. 3: DEEPSTAR 4000 heavy on the bottom.

Description--On dive 162, DEEPSTAR 4000 experienced a series of related and unrelated incidents that resulted in the vehicle becoming heavy on the bottom. Several of the emergency weight-dropping systems had to be used before the vehicle was able to surface.

Cause--Because vehicle was to take core samples, extra weight was desirable. The dive was made with the vehicle in a heavy (75-lb) trim condition, i.e., after the descent weight was dropped the vehicle was still negatively buoyant. Trim weights would be dropped to achieve neutral buoyancy if desired. With the vehicle on the silt bottom maneuvering around to place the core, tubes picked up about 100 lb of silt in the external fairing cavities.

The hydraulic system failed due to mechanical seizure of a face seal and the mercury trim system then could not transfer mercury forward to drive in the core tubes. It was decided to abort the mission and surface. The following events then became significant. The 186-lb ascent weight could not be released hydraulically; the manual back-up release was initiated; the weight hung up in its housing and did not drop. The small trim weights could not be dropped due to the lack of hydraulic power (about 150-lb capability). The

mercury of the trim system (200 lb) was released using the installed nitrogen blow system but the vehicle was still heavy.

In an unrelated situation, the variable ballast bottles had flooded (80 lb) due to faulty silver-brazed piping joints. The weight status of the vehicle from neutral buoyance was then: plus 100 lb of silt in the fairing, plus 80 lb of water in the variable ballast tank, plus 75 lb of trim weights (initial dive condition), making a total of +255, less 200 lb of mercury from mercury trim system equaling net 55 lb heavy.

The ascent weight of 186 lb was hung up and the vehicle was still on the bottom. Weight resources available included the vehicle brow with its scientific instrument suit (70 lb) and the forward battery (450 lb). Since the exact weight status of the vehicle was not known at the time, the forward battery was dropped (450 lb) and vehicle ascent commenced. The pitch up of the vehicle also shook out the ascent weight. A rapid safe ascent was made.

Corrective action--The hydraulic drive motor and seal system was repaired. The ascent weight housing was modified so that the weight could not hang up even at abnormal vehicle attitudes. The water-bottle type of variable ballast system was replaced with a hard tank/soft tank pumped oil system. The small weight dropper was modified so that the entire set of weights could be dropped mechanically.

As extensive as the corrective action was to DEEPSTAR, it is noteworthy that even with four unrelated incidents (silt, VBS flooding, hydraulic system failure, ascent weight hang up) the vehicle made a safe ascent and still had the brow release system in reserve.

Incident No. 4: Loss of power of STAR III.

Description--During operations off Bermuda in August of 1966, STAR III experienced a battery box failure causing a total loss of power. The vehicle surfaced by blowing the main ballast tank.

Cause--Investigation showed that the oil compensation system for the battery was not large enough and the battery box failed when subjected to abnormal external pressure.

Corrective action--The compensation system was redesigned to increase its capacity. The fiberglass battery box was replaced with a 316 stainless steel box of greater strength.

Incident No. 5: Lack of depth control of TRIESTE II.

Description--During sea trials TRIESTE II exhibited a lack of depth control in shallow water. As such, dives in water depths less than 1000 ft were not conducted.

Cause--Internal examination of the gasoline float showed that the air-vent holes in the ring stiffeners had been drilled with a conventional drilling tool. The size of the tool body resulted in holes being drilled 3/4 in. to

1 in. down from the inside of the float. When filled with gasoline, the air was not able to vent out of the float and a significant volume of entrapped air resulted. As a dive started, air would compress and an uncontrollable descent would result for the first 300 to 700 ft.

Corrective action--The holes were extended by grinding up to the inside of the float. Smooth controllable dives were then possible in shallow water.

Incident No. 6: Entanglement of buoys.

Description--On shallow missions Perry submarines (PC-5, SHELF DIVER and others) periodically tow surface buoys for tracking purposes. These buoys have occasionally become entangled in surface structures or the tracking ship. In one case, the ship caught the buoy line and actually dragged the submersible off course.

Cause--The buoy and buoy line were firmly attached to the submersible and there was no method available for the submersible to release the line if it became entangled.

Corrective action--A line release/cutter assembly was added to the submersibles so that the pilot is able to release the line.

Incident No. 7: Failure of hull penetrator in ALUMINAUT.

Description--While at 5500 ft off of Vieques Island on 14 August 1968, ALUMINAUT experienced a failure in the No. 1 hull penetrator. Water in a 1/4-in. stream entered the vehicle at the rate of 1 qt per minute. Ballast shot was dropped and ascent to the surface took 53 min.

Cause--A short circuit in the penetrator had burned across the O-ring seal, creating a water-leak path.

Corrective action--The penetrator was redesigned so that an electrical fault would not result in a mechanical failure.

These equipment failures relate primarily to electrical short circuits; they are, however, due to the presence of salt water where it does not belong. The water leak is then the real cause of the failures and mechanical design must be the key factor. With respect to pressure and leak integrity, the behavior of materials and components when subjected to ocean pressure must be adequately considered. Pressure acts in three dimensions. This effect is not often considered in catalogs for seals and gaskets - i.e., a seal for 3000-psi differential may not perform adequately in a 5000-to 8000-psi environment.

Pressure volume relationships, particularly in the first several hundred feet of water, are critical and due consideration must be given to compression-expansion phenomena.

Conclusions

Some 20 submersible incidents have been discussed. Considering that these

incidents cover 14 vehicles over the span of 5 years and several thousand dives, the safety and operational record of manned submersibles is extremely good. A review of the various incidents shows that most of them are connected with handling and at-sea use where seamanship, operational planning, and nautical skill are the key factors. In gathering background data for this paper, all of the vehicle operators indicated that pre-dive and post-dive checklists were vital to the safe operation of their submersible. A typical checklist set from DEEPSTAR 2000 is included for general information and guidance.

In only one-third of the reported incidents did submersible equipment designs play a significant part. A submersible is a specialized type of vessel and care and expertise must be used in its design and construction, but it is still a vessel to be used at sea by seamen. The need for good seamanship in its truest sense of the word must be realized and practiced.



B. THE SINKING AND RESCUE OF PISCES III: MR. H. PASS

PISCES III, supported by the mother ship VICKERS VOYAGER, was engaged in the burial of cable repeaters on the U.K. end of the newly laid CANTAT II cable. The unit arrived on site on 8 August and carried out routine dives until 22 August when she returned to Cork for a crew change. The second phase of the charter had been under way for some days and on Wednesday 29 August at 0100 hours, PISCES III commenced a dive at position 50° 0901 N, 11° 0707 W. The dive lasted for approximately 8 hr and PISCES III surfaced at 0918 hr.

The crew at the time were Roger Mallinson, Pilot in Command, and Roger Chapman, Senior Pilot, who was acting as observer. In my opinion, it is largely due to the behavior under stress of Roger Chapman that these two men are still alive. That is not to say the submersible would not have been recovered but, rather, that the outcome might have been very different.

In my Session I presentation I described the sequence of events in the recovery and I will take this up at the point where the tow line is attached to the submersible. The sea was far from calm at the time. Conditions have been variously described by eye witnesses but it seems likely that the waves were between 6 and 10 ft high at the time. The diver had climbed aboard the submersible and was standing in his normal position by the sail when the accident occurred. The aft-sphere hatch was held in place by four radial dogs which, in the locked position, engaged under the rim of the hatch opening. Locking and unlocking the dogs was effected by turning the nut on top of the hatch about 30°. (This small turning angle is in itself a significant contributor to the accident.) In normal circumstances the nut would have been prevented from turning by the locking handle. The locking handle was a simple, flat stainless steel bar with a hexagonal hole in one end and a round hole in the other. The hexagonal hole was orientated so that when the dogs were locked, the tail of the handle was secured in position by a nut on the vent plug, which also formed the seal on the vent itself.

It is necessary to go back a little further in the history to describe the most significant cause of the accident. In July the then operating PISCES III team had been forced to terminate several dives because of water-alarm indications. The aft sphere is fitted with an electric water alarm, which gives an audible and visual warning, but it does not discriminate between small and gross leaks and will, in fact, be activated by less than a teaspoonful of water in the sphere. A water alarm should be followed by immediate emergency procedure known as "X-ray"--rapid ascent made possible by blowing the air ballast tanks with compressed air. This procedure causes excessively rapid gassing of the batteries with consequent loss of electrolyte and a considerable amount of work for the maintenance crew. Investigation showed very small amounts of water, probably less than an egg cup-full, in the after sphere.

Eventually, the leak was traced by one of our senior pilots to a damaged thread on the vent plug that prevented the cap from sealing. He looked in the on-board stores for a new plug and cap but was unable to find them. Instead of having a new one made in the ship's workshop--which is fully equipped for this type of work--he took a shortcut and replaced the vent by a simple screwed plug with a seal under the head. This cured the water leak but, as a result, the locking handle could no longer be fitted. This action was in direct opposition to standing company orders stating that no modifications which could in any way affect the safety of the submersible may be carried out without the written approval of the Technical Manager, which at that time was myself. Had I been approached at the time, I am sure that the obvious risks would have made me refuse to approve this solution. There were mitigating circumstances in that PISCES III's sister submersible PISCES II had been operated satisfactorily over a period of 4 years with a similar hatch-dogging mechanism but without a locking handle. The significant difference, however, was that PISCES II was fitted with an aluminium fairing over the hatch cover which effectively prevented anything from contacting the locking nut.

At the time of the accident the tow line had been laid across the stern of the submersible by the action of the sea. The line had caught around the dog operating nut and was slack. Before the diver had time to lift the line clear of the hatch, a combination of wave action, ship's motion, and hauling in of the line caused the line to pull taut. In doing so, it turned the nut the necessary 30° and almost simultaneously flipped the hatch off. In the sea conditions prevailing, it was a matter of seconds before the aft sphere had become completely filled with sea water weighing approximately 2 tons and PISCES III rapidly submerged. The time was 0922. For a time PISCES III hung on the tow line directly below the ship at a depth of about 70 ft. The tow line parted at 0940 and PISCES III sank rapidly to the bottom, a depth of 1575 ft. In the short time between the tow line parting and the submersible hitting the bottom, the two men inside were able to rearrange equipment, seat cushions, etc. in the command sphere to lessen the effects of the inevitable collision. Descent was not as rapid as they expected and neither the men nor the equipment suffered much damage. At 0945 the crew reported that they were on the bottom and that the submersible was lying with its command sphere vertically above the aft sphere. This strange attitude resulted from the aft sphere being full of water and the 400-lb lead weight normally carried under the command sphere having been jettisoned in an attempt to prevent the sinking. Subsequently it was established that the vessel's attitude was approximately 72° to the horizontal but to the two men in the submersible the difference must have been purely academic.

The first intimation we had in the Barrow base was at 1000 hours, 15 minutes after PISCES III hit the bottom, when the Operations Controller, Mr. R. Henderson, reported the incident by radio telephone to the General Manager, Commancer Peter Messervy. A management meeting was taking place in the General Manager's office at the time so that, with the exception of the Operations Manager who was at sea with our other ship VICKERS VENTURER, all the senior managers of the company received the news simultaneously over the loud-speaker telephone.

One of the most significant features of the occasion was the complete ab-

sence of panic, both at the base and at the scene of the accident. Commander Messervy immediately assumed command of the rescue exercise and stated that no action was to be undertaken without his knowledge and approval. As a result, the whole operation was carried out in an orderly and well-planned manner. Commander Messervy then issued instructions to contact all organizations that had the ability to contribute to the rescue. This decision to enlist as much help as possible from the outset turned out to be one of the wisest.

First contacted was our second unit, VICKERS VENTURER and PISCES II, operating some 150 miles out in the North Sea. The Operations Manager, Mr. R. Eastaugh, was informed of the accident and instructed to get PISCES II ashore on the east coast as quickly as possible. The charterers of PISCES II, Phillips Petroleum, were contacted and permission was given to come off charter for the rescue.

Second, our friendly rivals in Canada, Hyco, were contacted and asked if they could send PISCES V to help in the rescue. Their response was immediate and their President, Mr. R. Oldaker, instructed his operating team to stop what they were doing and get ready to fly to Ireland with PISCES V and its support equipment. Hyco then made their own arrangements with the U.S. Air Force for a Hercules Aircraft to effect the transportation.

Next the U.S. Navy in London was asked if they would send DSRV and/or CURV. They replied that DSRV could not be put in a state of operational readiness in less than 48 hours, but that CURV could be mobilized almost immediately in San Diego. The request was made for CURV to be flown to Cork with all possible haste.

The Royal Navy was contacted as a matter of courtesy, since all our operations are carried out with the full knowledge of the R.N. While 1575 feet is well beyond the rescue capabilities of the R.N., a very useful contribution was made in sending the survey ship H.M.S. HECATE, which remained on site from early Thursday morning until the operation was successfully completed on Saturday afternoon. H.M.S. HECATE was used as a communications base during VICKERS VOYAGER's absence from the scene while she went to Cork to pick up the rescue submersibles. H.M.S. HECATE also rendered valuable assistance by loaning one of her Gemini inflatables when we experienced engine trouble with ours during the rescue.

At the beginning, VICKERS VOYAGER was instructed to remain on site to maintain communications with PISCES III until a relief ship arrived. The first ship to appear was the Royal Fleet Auxiliary, SIR TRISTRAM, which was used as a communications center pending the arrival of H.M.S. HECATE. VICKERS VOYAGER set sail for Cork at approximately 1815 hours on Wednesday almost exactly 9 hr after the sinking.

For my own part, my two main tasks were to assess the life support remaining on PISCES III and to prepare the lifting equipment for the recovery. The first of these was relatively easy as I had a report of the oxygen and CO<sub>2</sub> absorbent on board and it was simply a matter of making a realistic appraisal of oxygen consumption rate. The figure I used for the calculation was 0.5 liters per man-minute, which was intended to include a consideration for the

expectation that the naturally apprehensive mental state of the trapped men would increase their oxygen consumption above the minimum needed for survival in ideal conditions. It turned out this figure was conservative; their actual usage averaged approximately 0.3 liters per man-minute. I also checked the expected endurance of the CO<sub>2</sub> absorbent and this was considerably in excess of the oxygen supply.

The second of my tasks was more difficult: we had to decide what lifting equipment was needed and then manufacture it. At a conference with other engineers, a reference to the ALVIN incident resulted in the now famous toggle being sketched on the back of an envelope. The sketch was taken to the nearby Vickers Shipbuilding Company's plating shop, and by twelve noon, two of these toggles had been delivered to the Oceanics base and packed for transport to Cork.

Vicker's two light airplanes had been organized to ferry personnel and equipment to Cork. PISCES II had been transferred to a rig supply ship to speed up her transport to Teesport on the northeast coast of England. A Hercules aircraft had been organized to transport PISCES II from Teesport to Cork. Shipping agents in Teesport and Cork had set up local operations headquarters. Arrangements had been made for the Canadian cable ship, JOHN CABOT, to sail from Swansea to Cork to pick up CURV when it arrived from San Diego. A base operations-control organization had been established in Barrow. The U.S.S. AEOLUS had also been diverted to head for the scene.

Remaining minor but very important planning details were continued throughout Wednesday afternoon and, at 2020 hours, Commander Messervy and the base staff involved (including myself) flew to Cork, and went immediately to the office of the shipping agent whose premises were to be used as the Cork headquarters.

The next significant events were the arrival (on Thursday, 30 August) of PISCES V at 0330 from Halifax, Nova Scotia and PISCES II at 0412 from Teesport. These two submersibles with their support gear were loaded onto low loaders and transported to the dockside at Cork, arriving there at 0730 to await VICKERS VOYAGER's arrival at 0815.

At 1035 VOYAGER set sail from Cork; on board were PISCES II, PISCES V, support equipment, the base support team, and all other equipment considered necessary for the operation. In the following 13½ hours activity continued briskly in the hangar deck of VICKERS VOYAGER to prepare PISCES II and PISCES V for diving. In the meantime, the detailed recovery campaign was worked out. It was decided that PISCES II should make the first--and what we then expected to be the only--rescue attempt. It was also decided that a buoyant line would give the rescuing submersible greater freedom to maneuver since the line would stream straight up and clear of such things as propulsion motors, lifting hooks, etc. The toggle was fixed in PISCES II's manipulator with about 2000 ft of buoyant lifting line attached. The first 10 ft or so of this line from the toggle was lashed with light nylon lashings to various strong points on PISCES II's exostructure. The idea was that once the toggle hook had been placed in the open hatch of PISCES III's aft sphere and found to be firm, PISCES II could back off and break the lashings, leaving things clear for the lift to take place.

At 0100, VOYAGER arrived on site. At 0107, PISCES II was ready to dive and the normal operational launching sequence started with the launch of the Gemini inflatable boat. At this point snag number one occurred--the Gemini's engine would not start. Both spare engines also failed to start. Urgent action to put this right resulted in resumption of the launching sequence at 0200 hours.

PISCES II commenced her dive and reported that she was in sonar contact with PISCES III. At 0244 PISCES II was near the bottom and making good progress when suddenly the lifting line, complete with toggle hook, was wrenched from PISCES II by a combination of excessive buoyancy of the rope and severe weather topside. PISCES II was recovered so that the toggle could be refitted but examination showed that the manipulator had sustained severe damage and needed repair or replacement. Fortunately we had had the foresight to take along a spare manipulator from PISCES I. However, since replacement would take rather a long time, we decided that PISCES V should make the second rescue attempt. The head of the Hyco team, Mike Macdonald, elected to use a different type of hook which he had used successfully on a previous recovery operation. This was essentially a conventional open-crane hook fitted with a spring-loaded gate and an attachment which fitted the manipulator claw. His plan was to insert this hook in the main lifting eye of PISCES III. At 0545 PISCES V dived; at 0615 she reached the bottom and spent the next 6½ hr searching for PISCES III. The excessive time was caused by a number of factors. First, PISCES III's depth gauge was faulty. Second, the gyro compass fitted to PISCES V was drifting at a rate of about 30°/hr, which rendered direction from the surface extremely difficult if not impossible. Third, a trawler hired by representatives of the press and television hampered operations by sailing too near the site and thereby interfering with communications. This continued in spite of repeated requests for them to stay clear.

PISCES V was recovered and relaunched, because she had strayed too far from the PISCES III position. Finally, at 1244 PISCES V reported that she had PISCES III in sight. PISCES V then placed the lift hook in the eye on PISCES III. However, as PISCES V backed off, the lift hook rolled over and the safety gate opened, allowing the hook to slip out of the eye. PISCES V managed to catch the line but was only able to attach the hook to the starboard propeller guard on PISCES III. This guard was only a light tubular structure and in no way strong enough to be used as a lifting attachment. Unfortunately, this time the safety gate had worked and PISCES V could not dislocate the hook.

It was by now 1430 and PISCES V's batteries were very low. She was told by the surface to remain with PISCES III so that her pinger and underwater telephone could be used by PISCES II for location. In the meantime work continued feverishly on PISCES II to prepare her for diving again. The work was proving difficult and taking much longer than expected: personnel making the repairs had not slept for some 55 hr and, also, the weather had worsened to force 8 to 9 winds with waves up to 40-ft high.

Between 1430 and 1730 attempts were made to attach a choker sent from the surface down the line originally taken down by PISCES V, but her batteries were too low. At 1730, JOHN CABOT arrived on the scene with CURV, Commander Moss U.S.N., and Mr. Watts and Mr. Lawrence of Naval Undersea Center in San

Diego. They said that CURV would be able to insert our toggle into PISCES III's hatch without difficulty and that CURV would be ready to dive in less than 1 hr.

At 1950 PISCES II was launched again complete with toggle, nonbuoyant line, and stronger fastenings. However, she was still on the surface when she reported an aft-sphere water alarm and recovery was effected immediately. The time was then 2015. At 2130 a relief team arrived by helicopter from Barrow and took over the task of finding the fault in PISCES II.

Meanwhile CURV had reported that she was having troubles and launching would be delayed. The trouble turned out to be sea water in her main 55 way-cable joint which caused some essential equipment to burn out when the power was switched on. It took the CURV team, working flat out until 0400 on Saturday morning to rectify the faults. Prior to this, the relief team had ascertained that PISCES II's after sphere had not leaked sea water but that the water alarm was probably caused by a metallic foreign body shorting out the terminals of the water alarm.

PISCES II was relaunched at 0402 with toggle and 3½-inch polypropylene line. At 0505, PISCES II reported that she had placed the toggle in the hatch of PISCES III and that it was firm. This line had a specified breaking strength of 11 tons and could lift PISCES III near the surface for attachment of main lifting line but it was decided that, as an insurance, CURV should take down a second toggle and line. This decision was made in light of knowledge that the life support in PISCES III was holding out well and that the weather topside was worsening. At 0745 PISCES II was recovered. At 0940 CURV was launched with a second toggle and 6-inch braided nylon line. At 1030 CURV reported the second toggle fixed with positive lock. Decision was made to lift from JOHN CABOT since her lifting equipment and positioning ability were better than those of VICKERS VOYAGER. At 1100, the lifting operation commenced and, at 1109, PISCES III reported that her depth gauge had moved for the first time in 3½ days. At 1142, the lift had to stop temporarily with PISCES III at 350 ft because the lift lines had become tangled.

At 1205 PISCES III was within 60 ft of the surface. Lifting stopped so that divers could attach a heavy lifting line to the main lifting eye. In view of the physical state of our own divers, 3½ days without sleep, a team of U.S. Navy divers from U.S.S. AEOLUS volunteered. However, after approximately 10 min, the two divers surfaced in an exhausted condition and reported that because of the violent motion of PISCES III they could not attach the main line. Thus, one of Vickers Oceanics divers who was accustomed to carrying out this job went down and was able to attach the line very quickly. At 1247 the final lift commenced and at 1303 PISCES III's main sphere hatch was clear of the water.

At this time, extra lifting lines and a large mine flotation were attached for extra safety in the still worsening weather. At 1317, the command sphere hatch of PISCES III was opened and the two men climbed out, looking remarkably fresh after their ordeal.

In conclusion, I would like to say a few words about the precautions we

have taken to prevent recurrence of such an incident. The hatch-locking mechanism has been modified by the addition of a locking plate screwed in position. The whole area has been faired using a stainless steel-reinforced acrylic cover, which is fixed to the main skin of the submersible with eight screws. It is an important feature of the pre-dive checks to ensure visually that the locking plate is screwed in the locked position and that the acrylic cover is firmly attached. This would not prevent flooding of the aft sphere if, for instance, one of the electric or hydraulic penetrators should fail catastrophically. Either of these events is extremely unlikely because both types of penetrator have been designed such that only direct physical force or blows that could wrench the penetrators from the holes in the sphere could cause rapid flooding. I cannot conceive any circumstances in which the necessary blow or force could be imparted. However, the slight possibility remains and it has been suggested that the aft sphere should be jettisonable in such an event. We have considered this approach but the cost considerations when related to the probability of such a failure have ruled it out for our existing submersibles. For future designs, however, the possibility of incorporating this feature is being considered.

For our existing submersibles we have decided to continue with the policy of effecting recovery using either a rescuing submersible or an unmanned vehicle such as CURV. To facilitate recovery by such vessels our submersibles have been fitted with large-diameter emergency lifting eyes at a number of strong points.

To avoid damage to the rescuing submersible, such as that to PISCES II on her first rescue dive, all our submersibles have been fitted with a hydraulically operated release mechanism that exerts a firm hold on the rescue line until the pilot deliberately releases it. All our surface-support ships are fitted with the basic necessities to effect a rescue, including lifting line, special hooks, winches, and extra sheaves on the A frame to carry the lifting line. In addition to this, it is company policy to always have two submersibles on board during any charter which involves diving outside normal nondiving depths or which is so far from other operations that it would take an excessive time to get rescue teams and equipment to the site.

C. THE JOHNSON-SEA-LINK INCIDENT: D. YOUNGBLOOD, M D.

The tragic entrapment of a research submersible, the JOHNSON-SEA-LINK, resulted in the deaths of Al Stover and Clayton Link. Details of the incident have been described in the "Report on the JOHNSON-SEA-LINK Expert Review Panel to The Secretary, Smithsonian Institution, December 21, 1974," and Section L, Appendix II of Safety and Operational Guidelines for Under-Sea Vehicles, Book II, an MTS publication. The latter includes official comments replying to the Smithsonian report recommendation. What follows may occasionally differ from the published reports. It is not meant to be a contradiction or a criticism--only the recollections of one who was involved in some aspects of the rescue attempt.

The J-S-L, a lock-out submersible designed by Edwin A. Link, is unique in its use of an acrylic sphere for the forward compartment, affording unequaled visibility for the pilot and scientist-observer. Modifications to the original design included deletion of the diving planes, alteration of the propulsion system changes in life-support, handling, and gas systems, and in diver equipment. A number of these were completed during the spring of 1973 and the sub was given a complete overhaul. SEA DIVER, with the submersible aboard, put to sea on 29 May 1973 for proficiency training. The boat was (and still is) considered to be in the experimental and evolutionary stage of development, and had not been released as an operational tool for the use of marine scientists. Twelve dives between 31 May and 7 June were conducted and SEA DIVER arrived in Key West on 6 June.

It was an unofficial request from the Navy that promoted our initial survey of the U.S.S. FRED T. BARRY. The first dives on the wreck were made on 8 June 1973 and plans were made to conduct a series of dives of possible scientific utility while the sub was still in the proficiency training stage of operations.

Description of Accident

On 14 June, Bob Meek locked out of the J-S-L at 350 fsw alongside the wreck in an attempt to test a "slurp gun." Chris Swann was in the after compartment as diver-tender. Swann wore a wetsuit but Meek wore only cotton clothing for protection from abrasions. Due to neoprene's degree of compressibility, at depths beyond about 175 fsw there is little practical difference in insulating capability between wetsuits and simple fabric coveralls. Both Meek and Swann were cold in the 12.5% helium-oxygen atmosphere during the dive and the early stages of decompression. Menzies and I were comfortable in the acrylic forward compartment. The decompression was conducted without incident.

Discussions were held during a debriefing following dives on 16 June con-



cerning the desirability of obtaining cable cutters to mount externally on the submarine as part of its permanent equipment. We planned to purchase them in Key West on Monday, June 18.

Dive #130 was planned for Sunday, 17 June to recover fish traps in the vicinity of the BARRY's stern. A pre-dive briefing was held; Clayton Link and Al Stover elected to ride in the after compartment for observation and familiarization.

Prior to launching the J-S-L, Captain Link and I discussed the possibility of fouling in the wreck and wrote down our contingency plan. In essence it was as follows:

1. Notify the Navy and request an ASR with ready chamber and standby divers on station before attempting pressurization and disentanglement by the J-S-L divers.
2. If the J-S-L divers failed to free the submarine in 30-min bottom time, they would return to the J-S-L diver compartment and await Navy rescue.

One hour and eighteen minutes into the dive, while backing away from the third attempt to retrieve a fish trap, the submersible became entangled. While the pilot could see the cable and had approximately 20 ft of scope for maneuvering, he could not see the snap hook in which the cable was fouled. His instrument panel indicated an inoperative top aft motor; this led to the assumption that the cable was probably entangled in the top aft motor propeller, a misconception which affected decisions later regarding locking-out J-S-L divers. Without cutting equipment or even gloves, freeing a wire-fouled propeller would be time-consuming if not impossible.

The Coast Guard was notified at 0957 and they contacted the Navy in Key West. At 1012 the ASR TRINGA was alerted to get underway.

At 1045, the occupants of the forward compartment experienced symptoms of CO<sub>2</sub> buildup and found the CO<sub>2</sub> scrubber inoperative. A jury-rigged scrubber was effective in lowering the CO<sub>2</sub> level in the warm acrylic sphere.

#### Recovery Attempts

Extensive efforts were made by the support crew during the next 4 hr to place a heavy anchor with a 1-in. diameter nylon descending line near the submersible. A light polypropylene line had been attached to the wreck previously, but it was considered inadequate and it was feared that it might part if subjected to any strain. Efforts were made to maneuver a stronger line into the pilot's view by placing first a weighted pinger, then a pinger/transponder, and finally a weighted light on the nylon line and con them into position by two-way radio communication between a small boat and the SEA DIVER AND THE J-S-L. Even with the surface buoy for reference and the submersible's ability to track range and azimuth of the weighted pinger, our efforts were unsuccessful. There were apparently several currents setting in differing directions at depth, making placement a matter of pure chance.

The ASR TRINGA arrived at 1610 and we cleared the area for her 4-point moor maneuvering.

TRINGA completed a 4-point moor at 2018. Both her sonar gear and SEA DIVER's scanning equipment indicated that she was located over the submersible. Menzies, the pilot of the submersible, did not believe that the TRINGA was directly overhead. Before committing divers, he suggested that a clump with a bright light be lowered. This was done, and Menzies was unable to see the light despite 50 ft or more visibility.

While the sonar experts discussed their relative certainty of the submersible's location, SEA DIVER support-crew members began a visual search by towing a swimmer with mask and fins over the suspected location of the J-S-L. Communications to Menzies were relayed by UQC from SEA DIVER and he was requested to turn on the J-S-L's lights. After an estimated 10 min of search, we sighted a faint green glow. We obtained positive verification by requesting Menzies to blink the submersible's lights. By 2115 we had pin-pointed the subs location approximately 50 yd ahead of the TRINGA.

After further discussion, TRINGA winched ahead in her moor and, with her lights doused to prevent reflection, she verified our sighting of the J-S-L lights.

By this time CO<sub>2</sub> buildup in the diver compartment was severe. At 2205 the occupants were instructed to commence BIBS air breathing.

Meanwhile TRINGA was making preparations to dive. According to my recollection of discussions with the diving officer, 13% He-O<sub>2</sub> and 18% He-O<sub>2</sub> were available. Navy Diving Manual instructions will not allow dives from the surface with less than 16% He-O<sub>2</sub>, and the higher oxygen percentage mix was used, increasing the danger of CNS oxygen toxicity. The diving stage was on the BARRY at 2258, some 50 ft from the submersible, and Menzies had the divers in sight. As I recall the incident, communication was lost with one diver, who was reported to be "acting strange." At any rate, the 50 ft through the wreckage was judged impassable and the divers were started up at 2311.

By this time, exhalation had increased the after compartment pressure to 80 fsw. BIBS mix was shifted to 12.5% He-O<sub>2</sub> to reduce narcosis and keep the O<sub>2</sub> partial pressure as low as possible.

At 0015, Monday, 18 June, the bottom hatch of the diver compartment opened and the chamber pressure equalized at 350 fsw. It was estimated that perhaps a maximum of 1 hour of useful consciousness remained for the occupants of the after compartment and no help from topside would be available within that time. Therefore, it was recommended that a lock-out be attempted. Menzies discussed this with Stover, who apparently felt that the cold and CO<sub>2</sub> had so dulled their mental faculties that the risk was unacceptable. A lock-out was declined.

The occupants of the after compartment were instructed to close and dog the inner hatch, open both blow-down and ballast-vent valves, and pass control of the decompression to the forward sphere. The plan was to vent the chamber with the 12.5% He-O<sub>2</sub> to reduce the CO<sub>2</sub> and O<sub>2</sub>, accepting the risk of inevitable O<sub>2</sub> toxicity. No banks of pure helium were available on the submersible

at that time.

The second surface rescue attempt occupied the full attention of the forward-compartment occupants until 0218 when communication attempts with Al Stover and Clayton Link were unsuccessful. At 0235 Menzies reported that both blow-down and vent valves were only slightly cracked, not open as instructed, and, furthermore, he could not obtain a seal on the inner hatch. This would preclude dropping the battery pod and blowing all ballast tanks in a desperate attempt to break free as long as any hope remained that the J-S-L divers were alive. Breaking free of the bottom with hatch unsealed could cause a fatal explosive decompression.

At 0237 the Submarine Development Group One diving team arrived and began rigging their gear. There was a discussion of attempting a free dive down to the J-S-L using a modified Beckman Electrolung closed-circuit rebreather belonging to the Harbor Branch Foundation Engineering Laboratory. The plan considered was to have one swimmer descend, free the submersible, and lock into the after compartment for decompression. The electrolung had been on an inoperative status for 4 months; it had incurred repeated CO<sub>2</sub> breakthroughs in 17 min or less during cold-water tests at Duke University; and two unconscious--and probably dead--occupants lying on the inner hatch could prevent the electrolung swimmer from entering the J-S-L dive compartment, even if he successfully freed the submersible. The plan was abandoned.

By early Monday morning the occupants of the pilot compartment were becoming increasingly lethargic and depressed unless actual rescue efforts were visible. Communication was maintained on a continuous basis, fearing that if they fell asleep they might not reawaken. Periodic sampling of O<sub>2</sub> was done as a make-work task. Readings were erratic but high (20% or greater); however, the sample line exited the dive compartment near the forward bilges and it was felt some of the readings could result from "puddling" of unmixed O<sub>2</sub> from the bleed-in. A short bleed of pure O<sub>2</sub> was ordered at 0610. The reasoning at the time was that a little more wouldn't do much harm if CNS O<sub>2</sub> toxicity had already occurred but, if the divers were alive and unconscious, it would be tragic to allow them to suffer hypoxia.

At 0619 the roving bell and swimmer-divers reached 300 ft but could go no farther in the strong surface current.

At 1240 the PC-8 submersible was launched from the deck of the AMERJACK but her dive terminated with the loss of her sonar. At 1456 Menzies and Meek commenced intermittent BIBS breathing with pressurization of the forward compartment.

The ALCOA SEA-PROBE arrived at 1510 and made preparations to lower a drill-string recovery system. While the SEA PROBE was rigging, the A. B. WOOD was brought alongside TRINGA and lowered a T-V reconnaissance sled. Menzies guided the sled by relaying UQC to the SEA DIVER, which had radio contact with the crane operator. At 1640 a grapnel hooked the J-S-L and broke her free with approximately 3000 lb pull.

Menzies and Meek were assisted from the forward compartment and given pre-

cautionary recompression therapy. The occupants of the after compartment appeared to be dead, but the chamber was vented with a low oxygen mix and warmed while a saturation decompression schedule was assumed. Watches were kept throughout the night but, by morning, hope was abandoned and a linear ascent to the surface initiated. The chamber was opened at 2145 on 19 June and the occupants declared dead.

#### Review and Modification

Analysis of TV recordings made by the A. B. WOOD showed that the submersible had become fouled in a snap hook on the starboard quarter. Had the pilot known this and not assumed a fouled propeller, the decision to lock-out might have been different. The cable probably could have been easily freed. The present devices replacing the hooks are simple, streamlined, and strong. Table IIC-1 lists modifications that have been made to the J-S-L.

#### Other Submersible Rescue Concepts Currently Under Development at the Harbor Branch Foundation Engineering Laboratory

The Harbor Branch Foundation Engineering Laboratory, under the direction of Dr. Edwin A. Link, has developed a remotely controlled Cable Observation and Rescue Device (CORD) capable of locating a disabled submersible, surveying the situation by underwater television, and attaching a lifting wire to a suitable strongpoint by means of a self-locking grab device. This is shown in Fig. IIC-1

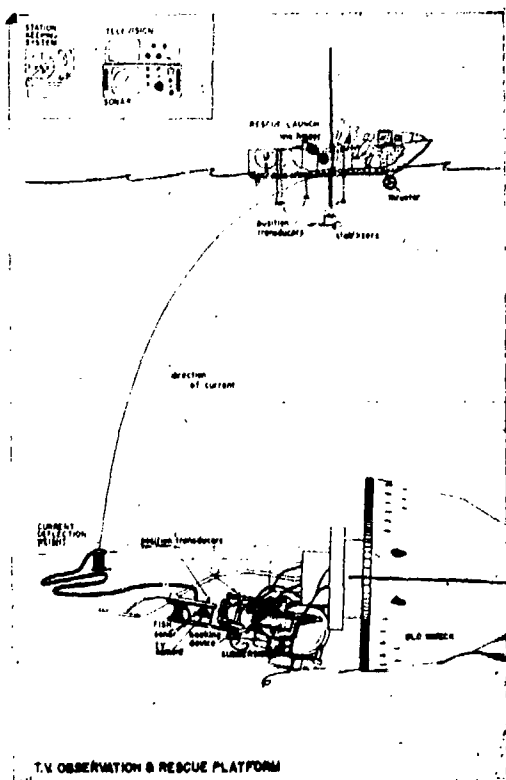

Fig IIC-1. Diagram of CORD rescue system.

Table IIC-1: Modifications to the JOHNSON-SEA-LINK

Diver	Compartments	Forward
<p>1. Lindberg-Hammer scrubber installed with LiOH used instead of Baralyme. Sufficient LiOH in compartment for 5½ days @ 70°F and 1 ATA.</p>	1.	<p>Scrubbers: new motors have been installed on the original scrubber. A spare charged canister is carried at all times, with sufficient LiOH for 5½ days. Plans include fitting the J-S-L 1 with a closed-circuit Bio-marine emergency life support system similar to the one being designed for the J-S-L 11. Carbon dioxide and oxygen monitors are installed in the forward compartment, as well as remote read-outs of CO<sub>2</sub> and O<sub>2</sub> levels in the after compartment.</p>
<p>2. Racks for protective clothing. Wool clothing is being used at present with plans to evaluate the very promising noncompressible wetsuits designed by Mancini and Mowrey, Inc.</p>		
<p>3. Two Biomarine CCR-1000 closed-circuit rebreathers modified to plug into the submersible's O<sub>2</sub> and inert gas supplies. "Buddy-breathing" adapters make either CCR-1000 unit capable of supporting two people in an emergency.</p>		
<p>4. Gas supplies: in addition to the usual HP air, oxygen and helium-oxygen mix, 2 reserve HP cylinder containing 1228 cu. ft. of pure He at 2400 psi have been added. There will allow, in the event of entrapment, the establishment of a low partial pressure oxygen saturation environment during pressurization. The J-S-L divers, using the CCR-1000 rebreathers and KMB-9 masks as modified by Innerspace Systems, Inc. would have ample time to attempt to free the submersible. Should they fail, they can return to a habitable atmosphere and await rescue.</p>		
<p>5. Atmospheric monitoring: a Beckman Minos oxygen monitor is installed in the after compartment along with a Beckman ACDM CO<sub>2</sub> monitor. Independent atmospheric analysis of the dive compartment will be available from the pilot's sphere.</p>		
<p>6. Communications: unscrambled "round-robin" helium communication is provided among diver, tender, and forward compartment.</p>		

7. Emergency equipment: a battery-powered compartment carries a hydraulic cable cutter and a hacksaw. A tool kit, spare O-rings, pressure-proof light, and a 5-day food and water supply are carried in the dive compartment.

General

1. Hooks: the snap hooks responsible for the 1973 entanglement have been replaced by a more satisfactory design.
2. External attachments: all possible external gear is attached by nylon bolts which will withstand impact loads but will "cold flow" and fail under a continuous load.
3. Drop lock: this has been redesigned for remote release. No swimmer is required for the launching, only for retrieval.
4. Increased payload: syntactic foam has been added over the upper half of the dive compartment, increasing the J-S-L payload from ~ 700 lb to ~ 2000 lbs. This allows additional separate emergency batteries to power communications and scrubbers for 5 days.
5. Deck decompression chamber: the new support vessel, R/V JOHNSON, is fitted with a below-decks decompression chamber which mates with the J-S-L for diver transfers under pressure and decompression aboard the support ship.
6. Rescue buoy: an inflatable emergency rescue buoy is now installed on the J-S-L. The buoy is attached to a reel of neutrally buoyant 4000 lb test FILISTRAND line designed to act as a guide for a drop-lock device that automatically attaches a full-strength wire cable to a lifting point on the submersible.
7. Pingers: the J-S-L is fitted with 37 kHz, 9 kHz, and 45 kHz pingers as described in the MTS article and comments. A pilot-actuated strobe light is also permanently installed.

The CORD is deployed from a rescue craft normally carried aboard the support ship. The support ship is equipped with sonar tracking systems capable of positioning the rescue craft within operating range of the submersible.

The rescue craft also has sonar plus additional positioning transducers which integrate range and bearing from acoustic "pingers" mounted on the "FISH" (CORD) and the stricken submersible. Electronic integration of this information allows the rescue craft to remain dynamically positioned over the submersible by means of hydraulic thrusters. A control console aboard the rescue craft allows the operator of the FISH to survey the position and attitude of the disabled submersible via underwater television prior to attaching the self-locking grab and its separate lifting wire to an appropriate strong point on the submersible.

The 2000 ft of multiplex cable for control of the FISH has a breaking strength of 10,000 lb. The cable is stored on a reel in the rescue craft and handled through a well near the craft's center of buoyancy by a 2-speed hydraulic line hauler. The multiplex cable between the Current Deflection Weight and the FISH is made neutrally buoyant or slightly positively buoyant by UG-36 floatation foam inside a polyethylene tube. This helps avoid entanglement of the FISH and aids maneuverability.

Although the multiplex cable could lift the wet-weight of the J-5-L (approximately 8000 lb), this is not planned as the normal operational mode. Instead the self-locking grab on the FISH is attached to a full-strength lift wire made fast to the Current Deflection Weight, and the grab is designed to break away from the FISH after attachment to the submersible strongpoint. A second full-strength lifting wire attached to a drop-lock device can then be sent down the multiplex cable/messenger wire to lock on to the Current Deflection Weight for lifting the submersible.

The Cable Observation Rescue Device (CORD) is in the early stages of testing and the FISH works well. The rescue craft is in the final stages of construction

Assuming the dry weight of the various components of the system, excluding the rescue craft, to be approximately as follows:

FISH	approx 720 lb
Control Console	approx 600 lb
Transducers, etc.	approx 600 lb
Line hauler	approx 250 lb
Cable and reel	approx 550 lb
Current Deflector	approx 300 lb

---

Total                      Approx 3020 lb

it would be interesting to consider the concept of rapid deployment of this device by air to any point in the world, transferring the system to a suitable helicopter, and operating the CORD from a hovering helicopter in order to attach lifting wires, etc., while conventional rescue ships proceed toward the site to effect any lift beyond the helicopter's capability, or to deploy divers if required.

## SUMMARY OF DISCUSSION

The question of how many of the small submersibles carry first-aid kits was raised. The DSRV carries a first-aid kit. What these kits should consist of was also asked. These items are sometimes forgotten in that most dives are routinely short. The crew in the Pisces incident survived on concentrated food products and they said that they could have lasted for about 4 days. It is a very good point that the Pisces victims did have sufficient food and water. They were able to drink the condensation from within the cabin. If one plans in terms of being trapped for days, provisioning and operational considerations are affected. One consideration is that if one eats more food, more oxygen is consumed. A person can survive for quite a long time without food, but water is a limiting factor, particularly in a heat-stress situation. In considering food, pure carbohydrates are preferred because they produce water in the metabolic cycle. Water requirements must be minimized.

The Marine Technology Society book on first-aid in submersible pilot training advises a standard course as taught by the American Red Cross or a branch of the military service, including, in particular, cardio-pulmonary resuscitation. The Lockheed training of civilian test pilots in the DEEP QUEST program did not include a cardio-pulmonary resuscitation training. While this specific training was never needed in the DSRV program, one of the trainees, happened on an auto accident and was able to use it successfully. It is a handy knowledge to have, even if one is not in submarine operations.

In Australia about 6 months ago a fellow was stung by what was probably a Sea Wasp. The victim became paralyzed and lost all respiratory function. He was kept alive in a diving bell and later in a DDC by mouth-to-mouth resuscitation. He was transported in a helicopter all the way back to a hospital, sustained by this method for a period of over 3 hours. In the small submersible most people think there is not enough power to cause electrical cardiopulmonary arrest, but this is not altogether true because if an electric shock impinges on the cardiac cycle at the right time it could cause a cardiac arrest or ventricular fibrillation.

A growing spectre among commercial diving companies is the interaction between diving personnel and hard and soft drugs. Operations have taken place in which up to 40% of the divers admitted to taking drugs. Additional information is needed to ascertain the seriousness of this problem and to provide guidelines for men working beneath the sea. What are the long term harmful affects? What are the synergistic affects with narcosis? How does withdrawal affect performance?

A point was made with regards to proper bladder function. One accident was described where a small submarine was dropped. Any physician that has dealt with trauma realizes that in an automobile accident, an airplane crash, or in the case of dropping a submarine on deck, if one of the occupants has a full bladder he can easily rupture it. The medical complications as a result of this type of accident can be quite serious, and can culminate in death from peritonitis. It might be wise to prevent such occurrences by insisting on the use of a Human Element Range Extender which is marketed for \$7.95 and commonly used in small aircraft.



## CONCLUSIONS AND RECOMMENDATIONS

1. It cannot be emphasized strongly enough that, in any operation at sea, there is no substitute for good seamanship and tested marine equipment.
2. The importance of understanding all possible operating conditions and planning ahead for them is essential.
3. With respect to pressure and leak integrity, the behavior of materials and components when subjected to ocean pressure must be adequately considered.
4. The contents of a first-aid kit for small submersible operations should be defined, together with the necessary training in the possible emergencies that could be anticipated.
5. The use of hard and soft drugs by submersible and diving personnel must be considered. What are the long-term effects? What are the synergistic affects with narcosis? How does withdrawal affect performance?
6. The Pisces incident has dictated the following precautions to be instituted by V.O.L.:
  - a. possible ability to be able to jettison the unmanned after sphere;
  - b. continue the policy of effecting recovery using either a rescuing submersible or a CURV-like vehicle;
  - c. to facilitate recovery by such vessels, V.O.L.'s submersibles have been fitted with large-diameter emergency lifting eyes at a number of strong points;
  - d. V.O.L. vehicles have been fitted with hydraulically operated release mechanisms which exert a firm hold on a rescue line until the pilot deliberately releases it;
  - e. all surface-support ships are fitted with lifting lines, special hooks, winches, and extra sheaves on an A frame; and
  - f. two submersibles will be on board for remote or hazardous operations.
7. The JOHNSON-SEA-LINK incident has dictated the following modifications to the vehicle:
  - a. Diver compartments
    - (1) increased CO<sub>2</sub> scrubbing capability sufficient for 5 days plus
    - (2) protective clothing (both wet and dry)
    - (3) two closed-circuit rebreathers
    - (4) increased gas supplies
    - (5) atmospheric monitoring of this compartment from the pilot's sphere
    - (6) unscrambled helium communication between diver, tender, and forward compartment
    - (7) emergency cutting equipment
    - (8) food and water for 5 days
  - b. Forward compartment
    - (1) increased CO<sub>2</sub> scrubbing capability
    - (2) closed-circuit rebreathers

- (3) improved atmospheric monitoring equipment
- c. Vehicle material changes
  - (1) more satisfactory snap-hook design
  - (2) all external attachments fitted with nylon bolts which will "flow-fail" under a continuous load
  - (3) swimmers only required now for surface retrieval
  - (4) additional emergency batteries to power communication and scrubbers for 9 days.
  - (5) deck decompression chamber on new support vessel
  - (6) inflatable emergency rescue buoy installed
  - (7) three pingers and a strobe light permanently installed

8. The Harbor Branch Foundation Engineering Laboratory has developed a remotely controlled Cable Observation and Rescue Device (CORD) capable of locating a disabled submersible, surveying the situation of underwater television, and attaching a lifting wire to a suitable strongpoint by means of a self-locking grab device. The CORD may possibly be operated from a hovering helicopter.

## SESSION III: BEHAVIORAL CONSIDERATIONS

### A. PERSONNEL SELECTION, MEDICAL QUALIFICATIONS, AND TRAINING REQUIREMENTS: LCDR R. BIRSNER MSC, USN

#### Personnel Selection

Purpose -- Valid personnel-selection techniques can be used to reduce training requirements by identifying those personnel with appropriate aptitudes for Deep Submergence Vehicle (DSV) operations, and those who have learned skills in comparable systems which may positively transfer to DSV operations. These techniques can also be used to identify those who may develop severe behavioral or psychiatric problems under the isolated and stressful conditions typical of many DSV operations.

#### Current Selection Procedures

Within the Navy, selection standards for uniformed personnel as well as civilians aboard Navy DSVs are specified in OPNAVINST 9290.3. This instruction states that such personnel must meet submarine qualification standards. In addition, SECNAVINST 6420.A requires that a physician evaluate personnel on "motivation, fears, and anxieties (especially claustrophobia)" prior to their operating, or observing from, DSVs. The examining physician does not have to be qualified in psychiatry or in submarine medicine. These medical evaluations are to be performed annually.

Personnel selection standards for civilians aboard nonmilitary DSVs involved in nonmilitary operations are primarily managed by the Marine Technology Society (MTS). MTS has proposed that divers be used as the principle personnel resource. The MTS standards for personnel selection and psychological evaluation are minimal and ambiguous and rely heavily on the psychological screening processes of other systems (primarily Navy). MTS proposes that claustrophobia should be evaluated as well as responsibility, initiative, and mechanical aptitudes. These factors are not defined, nor is the rationale for emphasizing these particular factors provided. Also, the authority responsible for performing these evaluations is not identified.

MTS states that an annual psychiatric evaluation is unnecessary. Although evaluation by a qualified psychiatrist may be difficult and expensive, the present author recommends that the examining physician should interview DSV personnel about possible psychological problems using a structured interview form such as the "Life Crises Questionnaire."

#### Assessment of Current Selection Procedures

I concur with the MTS statement that the small number of DSV personnel does not warrant developing an extensive research program for DSVs alone. However, some psychological factors important to effective DSV operations (especially responses to social and sensory isolation, boredom, fatigue, and so

forth) do have sufficient commonality with other systems (spacecraft, saturation diving, Antarctic operations and submarines) to justify using DSVs as a testbed for developing psychological methodologies for these other, more elaborate, systems. This concept would be similar to the BEN FRANKLIN relationship to the space program. The use of DSVs as a personnel testbed is further justified because situations like Operation Deep Freeze are not readily accessible, while diving situations such as SEALAB and TEKTITE are rare.

Too much emphasis is placed on mechanical aptitudes and previous experience in other submersible systems. Most DSV systems are simple enough to be learned by those with above average intelligence and the motivation to learn. The question also arises whether experience with different submersible systems may impede performance on DSV systems through negative transfer of training.

Interviews with Submarine Development Group One training officers indicate that most DSV pilot-copilot trainees are volunteers from the available pool of conning officers stationed aboard diesel submarines. It appears that the rapid decommissioning of diesel submarines has been an important factor in most of these personnel volunteering for DSV service. The diesel-submarine resource provides some training in electrical-mechanical principles similar to (although more complex than) those used on DSVs. Specific equipment layouts and controls may differ substantially between the two systems, giving rise to the possibility of negative transfer of some cognitive and psychomotor skills.

The navigation skills learned aboard submarines are acknowledged to be the most important skills transferable to DSVs. Relative positioning, obstacle avoidance, and object detection and identification are crucial navigation skills for DSV operations. Navigation is the key factor in successful DSV missions, superseding even trim and control skills.

Another factor that submarine experience contributes to DSV selection process is social adaptiveness. This is the ability to interact with others, at least at the occupational level, during periods of prolonged social restriction or interpersonal conflict. By serving successfully aboard submarines over a number of patrols, these personnel have successfully demonstrated this characteristic. It should be mentioned, however, that most critical interaction patterns are part of the command structure of submarines; controls exist at many levels to avoid or remedy interaction breakdowns at lower levels. These multilevel controls do not exist aboard DSVs. DSV personnel must learn to recognize early the signs of social conflict and minimize its impact on operational performance. It would appear that previous submarine experience might develop this characteristic and selection of DSV operators from submarine resources should continue as long as possible.

Recruitment of pilots-copilots may be a problem in the near future following decommissioning of diesel submarines. DSVs are unlikely to get qualified nuclear submarine officers because of shortages and priorities within the nuclear fleet.

Aviators are also an unlikely prospect. The shortage of qualified junior aviation officers is chronic and aviation has recruitment priorities over DSVs.

Experienced aviators (senior O-3s and O-4s) who have decided not to enter the administrative career pattern required for advancement in aviation are not likely to volunteer for DSV service because the advancement opportunities are poor. In addition, the slow-performance characteristics of DSVs would be a source of motivation and psychomotor problems for aviators. (A few of the remaining blimp operators, however, may be interested.)

The next most likely resource may be divers. As mentioned before, this resource has been recommended by MTS. The selection of divers would present some problems, however. Previous research has shown that divers do not adjust well to many social situations. They maintain autonomy and have difficulty containing anger if that autonomy is threatened. To reduce the possibility of social conflict, it is recommended that divers with as much saturation diving experience as possible be selected. Previous experience with restricted habitat conditions would serve to develop the ability to cope with interpersonal conflict.

Saturation divers also have experience with hardware systems similar to those of DSVs. Diving experience would not provide much in the way of vehicle control and navigation skills, but there would be no problems with negative transfer.

#### Miscellaneous Selection Procedures

Visual requirements -- The SECNAVINST which requires 20/70 visual acuity correctable to 20/20 for observers seems too capricious. Although visual acuity is important to the search and location operations for DSV's, it is nonetheless considered appropriate to require only correctable vision, regardless of refraction.

A useful visual requirement for both operators and observers would be the development of effective (nonredundant) scan patterns, as well as perceptual field independence (which is the ability to locate target objects in a complex visual field). These skills should improve the speed and accuracy of object location and identification, thereby reducing mission time. It is doubtful that the DSV training program could tolerate these visual requirements in the selection process, but these skills could probably be acquired by training (see below).

Vestibular requirements -- None of the documents reviewed mentioned motion sickness or any other vestibular problems as part of the screening process. It is probably assumed that those with vestibular problems were screened out in submarine service. (If this process were carried to the extreme, perhaps destroyer personnel would be best suited for DSV operations.) Vestibular problems, however, usually subside once a submarine is underway and, even then, may not be readily detectable in performance not directly related to vehicle control. The situation is more critical in DSVs. Rough surface conditions and severe angles of attack during a dive may result in vestibular effects which could degrade pilot control performance for hours afterwards. Under DSV conditions, in which control of the vehicle and manipulators relies heavily on

vestibular cues, it is highly recommended that vestibular screening be incorporated as part of the medical examination. More attention from the research community might be directed toward this problem, with possible application to other small vehicle systems.

Summary of selection procedures -- Procedures and standards for both the Navy and civilian DSV communities are often not well defined or regulated. Selection techniques used in comparable situations could be applied to DSV personnel selection. Similarly, DSV operations could serve as testbeds for additional psychological screening and selection techniques for the mutual benefit of both the DSV and related systems. Research areas might include the psychological effects of isolation, small group interactions, fatigue, visual-perceptual abilities, and performance (control) effects related to vestibular disturbances.

#### Training Requirements

Purpose -- This analysis of DSV training is intended to specify techniques by which mission objectives can be more rapidly or effectively met through training, identify areas in which training can overcome personnel selection constraints mentioned in the previous section, and recommend ways in which present training resources could be used to reduce training time or improve the quality of trained personnel.

#### Current training programs

Navy -- Interviews with Submarine Development Group One training personnel indicate that crews aboard Navy DSVs (including DSRVs) are expected to rotate every 3 years, resulting in a maximum annual training load of 25 trainees to replace current Navy crews. This small training requirement does not warrant extensive training research unless the results again have applications to other small crew systems (see previous section). The Navy must make maximum use of training technology now centralized under the Chief of Naval Education and Training (CNET).

Navy DSV training is now largely academic, emphasizing concepts, checklists, and cockpit familiarization. This training is managed under a formal syllabus. Refresher training is given only at the request of the DSV operator and does not follow a formal syllabus.

Vehicle control training for Navy pilots-copilots and trouble-shooting/launching training for the crew is accomplished on the job (OJT).

Civilian -- A review of the MTS and Woods Hole training programs indicated that these programs do not use a formal syllabus. The course outlines emphasize academics (familiarity with DSV technical manuals). OJT was used for training vehicle control skills (psychomotor performance).

#### Assessment of Current Training Procedures

The improvements which are recommended below are not unique to DSV training.

Again, action on many of these recommendations may have to be justified in terms of establishing a model training system for other training situations involving small groups.

The present Navy DSV syllabus should be based on current training technologies, including task-analysis and the Systems Approach to Training (SAT). In order to design a more effective syllabus, training objectives should be defined in terms of specific skill factors (cognitive, psychomotor, and motivational) and the levels of proficiency required for each skill should also be specified. Training developed on specific, measurable performance objectives also prevents conflicts which may arise if trainees are evaluated by subjective methods. Such conflicts are especially detrimental in small group situations. In addition, objective training performance criteria could be used not only in validly measuring trainee effectiveness, but also in evaluating both personnel management and selection techniques and equipment design and procedures. It is recommended that assistance in using current training technologies for developing an improved Navy DSV training system be requested from CNET through the appropriate training command structure.

The following paragraphs present specific training areas which may be improved using current training technologies:

The present Navy syllabus should be designed to permit more flexibility in the training sequence. Progress should be based on initial skill levels and speed of learning. The trainees (both operators and crew) have highly different skill levels, aptitudes, and intelligence and more provision should be made for those who demonstrate unusual competence or learning ability to advance more quickly. Training should be based on objective, measurable test performance.

More use should be made of available simulators. The small numbers of DSVs, low vehicle-operating costs, and the availability of vehicles for training purposes does not warrant building additional simulators. SEA CLIFF/TURTLE, TRIESTE, and DSRV have associated simulators, although some problems would have to be overcome before these devices could be put to effective training use. The following simulator problems and possible solutions were found:

(1) The SEA CLIFF/TURTLE device is at the Naval Training Equipment Center (NTEC) and funds must be provided through CNET O&MN resources for shipping and housing. If this device were programmed into a syllabus emphasizing current training technology, its cost-training benefits could be more readily demonstrated and funds could be better justified.

(2) The TRIESTE II device has a number of software configuration problems, including the navigational logic. The major configuration problem is the use of two (instead of four) shot tanks. This limits training related to ballast and trim control. The TRIESTE manipulator dynamics are also outdated. Manipulator control panel cues are not easily read. The cost of correcting these problems could be easily justified if use of the device were formally integrated into the training syllabus.

The device warrants better use as a familiarization and procedures trainer, and as a basic instrument trainer. It could develop major psychomotor skills. In addition, its most important use may be training in emergency procedures, including electrical and sonar failures, shot loss, venting and rupture casualties, loss or fouling of the stabilizer ball, propulsion problems (control of thrust or motors), bottom problems resulting from fast approach (fouled skegs), and emergency jettison procedures. Training in emergency procedures is now limited to academics and actual occurrences. The device is occasionally used for refresher training but this is voluntary. It is recommended that refresher training be made a formal requirement and incorporated into the formal training syllabus. It is also recommended that if this device is made part of a formal syllabus, a continuous graphic plotter should be substituted for the present end-point plotter. This will be a significant reinforcement factor during instructor debriefings. It is not necessary for the device instructor to be a DSV operator. A device technician could serve in this capacity if given a short-course in training techniques. This is true of other devices as well. It must be emphasized, however, that in order to instruct effectively the criteria of successful performance must be well defined in objective terms.

NTEC has proposed a motion platform (pitch and roll) for the DSRV device, but present use would probably not warrant this addition. It would have to be justified in terms of training effectiveness and the high cost of operating the actual vehicle for training. The tandem-TV/submarine-model configuration presently used probably provides the majority of cues necessary for vehicle control. Priority should be given to developing a more effective use of this technique. A similar model has been developed by the Air Force to teach formation flight skills. It does not provide cockpit (inside) motion, only outside motion through a TV/aircraft-model interface. Training effectiveness, safety, and cost benefits have been documented.

More use should be made of mockups, especially for training in cockpit familiarization, emergency egress, and launching procedures. Using an actual vehicle for these procedures is both expensive and hazardous. The correct location of indicators and controls could be easily accomplished by using cardboard or styrofoam mockups. The hazards involved in emergency egress from the actual vehicle is currently an academic topic but training with cardboard or styrofoam mockups could help prevent injuries during egress practice. Training could be timed and objective performance criteria could then be established. Personnel should practice from different positions in the vehicle and some of the later practice trials should be under reduced-light conditions.

Training for launch procedures is currently OJT. The use of mockups would reduce the possibility of damaging vehicles. A task-analysis should be made of the launch procedures and each crew member should be instructed as to the exact tasks to be performed. This would avoid confusion, overlap, and



interference. Again, criteria of correct launch performance for each crew member should be established in objective terms and made available to the crew as a training goal.

The crew should also be given some instruction in proper lifting techniques in order to avoid back and joint injuries. Instructional materials in this area have been developed by medical personnel. This material can be learned in only a few hours without lecture (to conserve medical personnel for other purposes). Information on handling large objects in negative-g situations may be helpful in handling the vehicles in water.

Some first-aid training, with special emphasis on potential DSV casualties, is recommended. Areas covered might include treatment of cuts, sprains, fractures, and chemical poisonings or burns (casualties involving battery acids, lithium and barium hydroxides, mercury, and O<sub>2</sub>). This training could be easily accomplished using a programmed text, instead of scarce medical personnel.

Maintenance training for Navy DSV crew members is currently academic and OJT, emphasizing 0-1 level maintenance (identification and replacement, not repair). The Navy TRAGRUs are currently using training panels which permit some hands-on troubleshooting practice. These panels should shorten the OJT phase of training. The panels are substantially less expensive than actual hardware and are designed to simulate several different systems (electrical, hydraulic, etc.). They have been well received by instructors and students. They are also being used by pilots for aircraft familiarization.

MTS has recommended that DSV operators should have training in photographic techniques. Inasmuch as visual data collection is a primary mission of DSVs, this recommendation is highly supported. Photographic training should, however, be specific to oceanographic conditions and the maneuvering characteristics of the vehicles. Training in controlling the vehicle relative to the observer port may be in order. Present DSV simulators with TV interface may be well-suited for this type of training.

The MTS Study Group recommended that more team training should be done. This is highly supported and should involve most phases of DSV operations. It is especially necessary for launch procedures and observer-pilot interactions. If done properly, it would not only save time but would help to prevent conflicts arising from task confusion and interference. Team training should be based on a task-analysis. A time-lapse photography technique similar to that used on the BEN FRANKLIN (and to some extent on SEALAB and TEKTITE) would be extremely useful in collecting task-analysis data.

The MTS Study Group also recommended that more standardized data be collected on mission conditions such as depths, turbidity, control problems, equipment failures, and accidents. These data could then be used in establishing more representative mission scenarios for training purposes. Again, this recommendation is fully supported.

Although it is recognized that knowledge of vehicle systems (electrical, hydraulic, and so forth) is necessary for the operators and much of the crew, some care should be taken to carefully define the conditions under which those who do not have primary responsibility for systems maintenance can assume that responsibility. These conditions should be based on objective performance measures obtained from the above task-analysis. This procedure will help reduce overlap and unnecessary interference, and should promote crew motivation and avoid crew conflicts.

The problem of cross-training among DSVs has not been resolved because data on training transfer have never been collected on which to base valid decisions. It is therefore proposed that DSVs be used as a testbed for transfer of training research. This research would contribute to basic knowledge in this area and may have immediate application to other hardware systems in submarines and aviation (especially in systems maintenance). This research cannot, however, be accomplished until DSV performance is defined in objective and measurable terms.

It is also proposed that DSVs be used to research the performance requirements involved in remote-control operations. The heavy reliance of DSVs on TV sensing and remotely controlled manipulators provides a rare opportunity to analyze the sensorimotor parameters that are necessary to operate these systems effectively. This research would have application to the design and training characteristics of future RPVs in aviation, as well as other submersible systems.

Requalification of Navy DSV operators is presently controlled under OPNAVINST 9290.3, which states that recertification is necessary if the pilot-copilot has not operated a vehicle in more than six months. Data are not available on performance deterioration among DSV operators, but recent aviation findings show that deficits occur after 30 days. Although it is recognized that aviator skills are more complex and therefore more susceptible to deterioration than those of DSV operators, it is nonetheless recommended that the present recertification period be shortened to not more than 60 days and preferably 30 days. Also, data should be collected on performance deterioration so that these regulations can be more objectively established.

#### Summary of training procedures

Current training objectives are not well-defined in terms of measurable performance. More use should be made of available training technologies to objectify the DSV training situation and to redesign training programs accordingly. The identification and improvement of some DSV training problems will depend on the possible applications to comparable systems. Critical problem areas include the use of simulators and mockups, maintenance training, crew-task interactions, cross-training, and training for remote control operations.

B HUMAN-ENGINEERING EVALUATION OF THE SDL-1: DR. D. ATTWOOD AND  
C. McCANN (presented by LT. B. MARTIN, C.F.)

The need for a human-engineering evaluation of SDL-1 was first recognized during a conference held at the Defence & Civil Institute of Environmental Medicine (DCIEM) during November 1971. The operators of the submersible reported discomfort caused by extreme cold and inconvenience caused by restricted vision and poor equipment design and layout. In August 1972, D.A. Attwood and C. McCann, of the Behavioural Sciences Division of DCIEM, conducted the evaluation in order to be able to recommend specific modifications that would improve operator comfort and performance.

Vehicle Description

SDL-1 has been based at the Fleet Diving Unit (Atlantic), Halifax, Nova Scotia, since December 1970. To date its missions have been search, survey, and salvage. Normal mission time of the submersible is limited to 6-8 hr by the capacity of the Propulsion System batteries. However, 200 additional man-hours of emergency life support are provided.

SDL-1 is a manned, untethered submersible with a diver lock-out capability. It has a maximum operating depth of 2000 ft (sea water) in the 1-atm and a maximum lock-out depth of 1000 ft (sea water).

The submersible (Fig. IIB-1) is approximately 20 ft long, 10 ft wide, 12 ft high, and weighs 15 tons in air. The hull is composed of two pressure spheres and a connecting tunnel which is surrounded by a tubular frame and fiberglass fairings (Fig. IIB-2). The forward, or control sphere (CS), is 7 ft in diameter, can accommodate a crew of three, and contains all operation, control, and monitoring equipment. The rear, or lockout sphere (LOS) is 5 1/2 ft in diameter and is also designed for a three-man crew and their equipment.

Propulsion and steering are provided by two DC electric thrusters, mounted on either side of the vessel. Maximum speed is 1 1/2 knots in still water.

Buoyancy is controlled by two separate (water-air) ballast systems: a hard system and a soft system. In an emergency, positive buoyancy can be achieved by jettisoning two 350-lb lead drop weights suspended below the lower battery box. The thrusters and manipulator claws may also be jettisoned if they become entangled. Pitch can be controlled by moving the lower battery box forward or aft.

To perform simple work tasks, SDL-1 is equipped with two external electro-hydraulic manipulators. One manipulator has 3° of freedom while the other has 6° of freedom.

Scope

This paper summarizes some of the observations made by the DCIEM team during the 2-week evaluation period. The conclusions drawn are based both

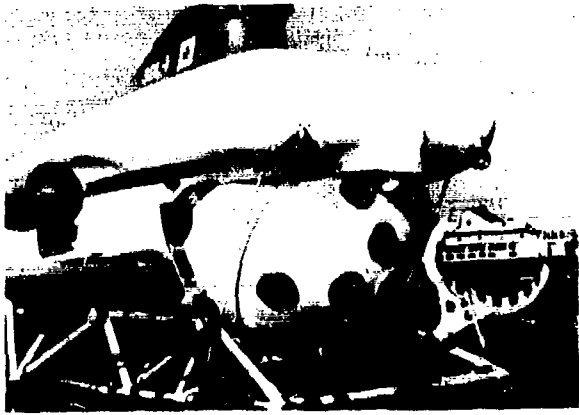

Fig. IIIB-1. Submersible diver lock-out 1.

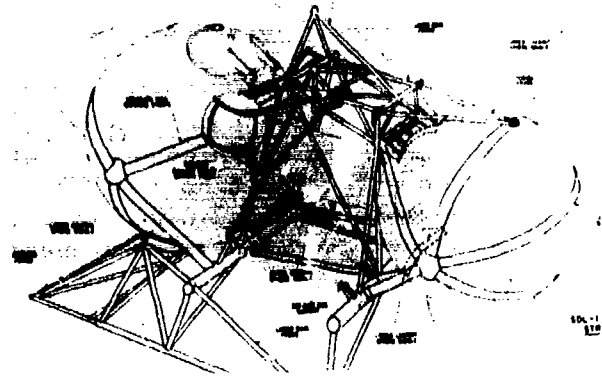

Fig. IIIB-2. Hull-frame assembly.

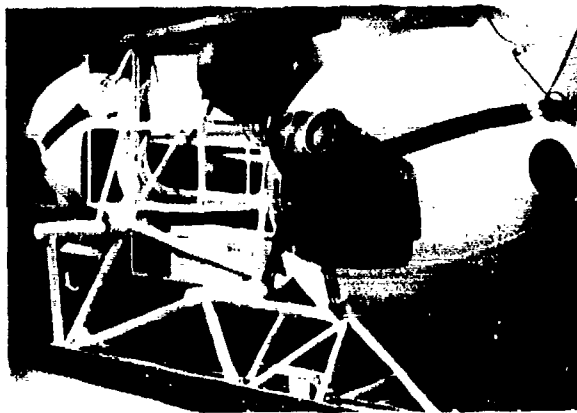
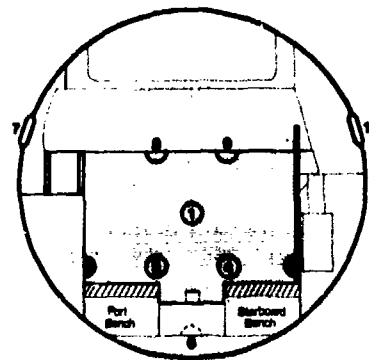

Fig. IIIB-3. DCIEM Mockup.



PLACEMENT OF VIEWPORTS

Fig. IIIB-4. Placement of viewports.

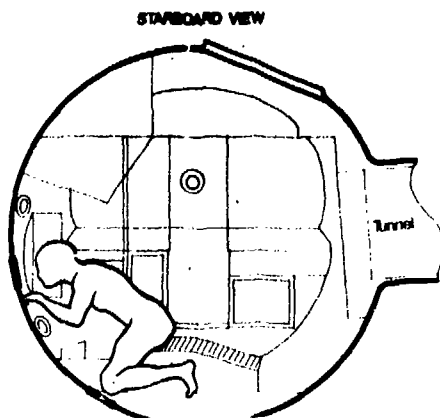

Fig. IIIB-5. Fluted pilot seating position.

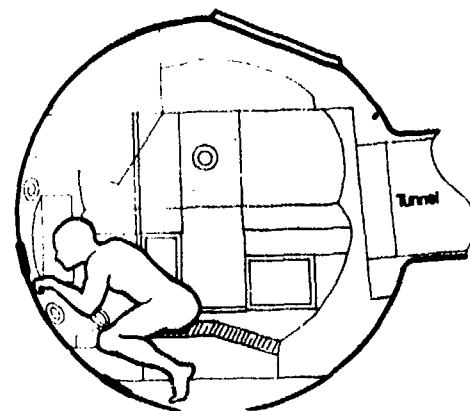

Fig. IIIB-6. DCIEM pilot seating position.

on human-engineering principles and on practices employed in the design of other submersibles. Solutions of some particular problems are discussed, and illustrated with the aid of a full-scale static mockup of the vehicle (Fig. IIIB-3).

### Constraints

Critical limitations in payload, endurance, and work space greatly constrain the scope of the human-engineering recommendations. It is not feasible, for example, to improve the operating characteristics of the vessel by adding more weight in the form of new equipment or additional life support supplies or to make recommendations that would constitute a drain on the power supply. The command and lock-out spheres are already crowded with people and equipment. The limited space which is available must not be wasted with unnecessary equipment or inefficient equipment layouts.

### Major Problems Evaluated

Vision and seating in the control sphere -- Fig. IIIB-4 shows an interior forward view of the control sphere. The pilot normally uses viewport No.1; copilot and observer use viewports 2 through 5; the remainder are seldom used because of poor external lighting.

For the pilot to use the center viewport he must assume the position shown in Fig. IIIB-5: kneeling on the deck, supporting himself with one hand on the hull, and operating the propulsion control with the other. This position not only restricts movement, it is also extremely uncomfortable and results in the pilot and copilot having to change positions frequently.

It is necessary, therefore, to seat the pilot more comfortably. It is impossible to place him close enough to the viewport to provide adequate outward vision in the upright position. The addition of visual aiding systems, either passive with an optical viewing system, or active with closed-circuit TV, or relocation of the viewports were too expensive to be considered.

The solution adopted was to seat the pilot with his body forward so that his weight is distributed over his seat, knees, and chest (Fig. IIIB-6). Fig. IIB-7 shows a mockup of an early version of this new seating arrangement. By photographing several subjects in various seated positions, body angles could be calculated and then compared with the recommended limits of extension and flexion for separate body components. In this way a variety of seated positions were evaluated and the best chosen. The final result is shown in Fig. IIB-8, as installed in the mockup.

The copilot and observer seating positions are possibly even worse than that of the pilot. They require the occupants to assume a prone position on either side of the pilot to look through the lower viewports (Fig. IIIB-9). The problems associated with these fitted benches are severe neck angles and fatigue resulting from the body being supported by a firm surface.



Fig. IIIB-7. Pilot seating position mockup.

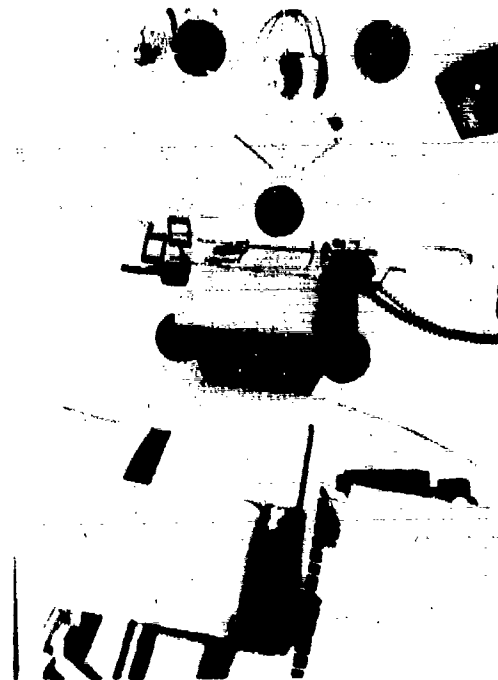

Fig. IIIB-8. Pilot seating position in full-scale mockup.

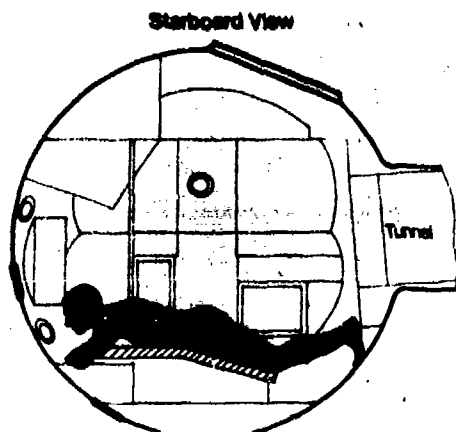

Fig. IIIB-9. Fitted copilot-observer seating.

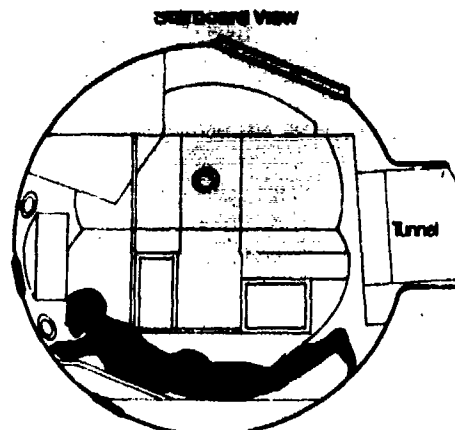

Fig. IIIB-10. DCIEM copilot-observer seating.

- DISPLAYS**
- Propulsion-Navigation**
1. Direct forward vision
  2. Surface vision
  3. Motor status - overload
  4. Over
  5. Depth and height
- Trim-Ballast**
6. Pitch
  7. Roll
  8. Trim box - pos'n
  9. Soft ballast water level - overload
  10. Hard ballast water level
- Communication**
11. Switch system
- Controls**
12. Control
  13. So
  14. So
  15. Hard
  16. Comm. sw.

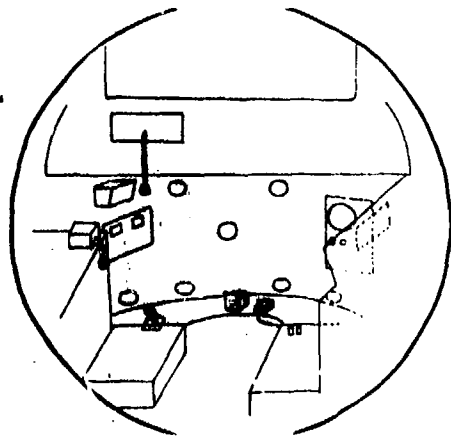

Fig. IIIB-11. Pilot's control-displays.

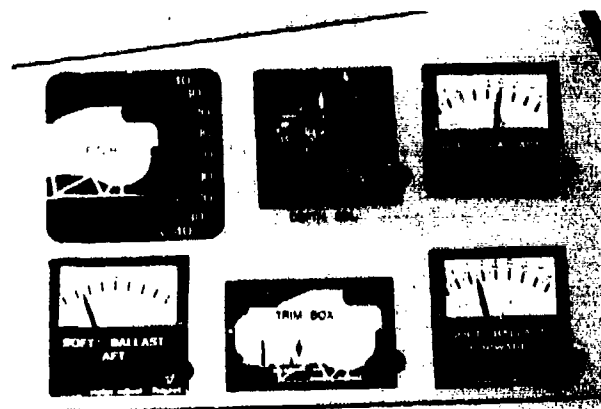

Fig. IIIB-12. Pilot's control display panel 2.

A review of research on the prone position in flying done in the early 1950's was made, and it was learned that Clark et al., at Wright Patterson AFB, had demonstrated that hammock supports could reduce fatigue caused by body excursions on a hard surface by a factor of 10, enabling pilots to maintain a prone position for up to 2 hours at a time. Consequently, a hammock-like support was designed and fitted in the mockup (Fig. IIB-10). The torso support was angled downward enough to decrease neck angle, but not enough to create lower-back discomfort.

Controls and displays -- Another major problem area in the design of SDL-1 was that of controls and displays (C/D's). The information requirements of the pilot and copilot were identified, then considered in relation to the fitted instrumentation. The table on the left of Fig. IIIB-11 lists the C/D's that are required by the pilot. The sketch illustrates that location of each C/D he is provided. The comparison indicates that:

- Many C/D's are poorly laid out. For example, pitch and roll inclinometers are located behind the pilot.
- Many are poorly designed. For example, the depth gauge is poorly lighted and difficult to read because of fine graduations; also, propulsion controls require two hands to operate.
- Many C/D's are missing. For example, no surface vision is available and no information on trimbox position is provided.

In addition, Fig. IIIB-11 demonstrates that the C/D's the pilot needs are scattered throughout the control sphere.

To solve these problems, new C/D's were designed to provide new information and control factors; old C/D's were redesigned; and all controls were grouped into two panels. The display panel located on the port side (Fig. IIIB-12) contains the following displays: pitch indicators, trim box position indicators, depth display, and ballast-tank content displays. The main panel, which is located on the pilots chest rest (Fig. IIIB-8), contains: displays for surface vision that include a CCTV console and controls, redesigned propulsion controls that allow one-hand operation, motor-status lights, ballast controls, heading information (gyro repeater), propulsion and ballast motor-overload lights, and roll and pitch lights.

Design and layout of the Life Support System C/D's constitutes another major problem. This instrumentation is very complex, with over 200 C/D's in the control sphere alone (Fig. IIIB-13). Although there are distinct subsystems (for example, oxygen, LOS pressurization, and LOS depressurization) and distinct functions for the C/D's within subsystems, they are not readily apparent in the layout. In order to simplify the identification and recognition of subsystems and C/D's within them, all subsystems were distinctly separated in-

to function groups, and color-coded where possible. Within subsystems, C/D's were laid out in order of sequence of use. Also, controls were shape-coded according to function (Fig. IIIB-14).

Displays were also redesigned: they were reduced in size without sacrificing information; bezels were color-coded by subsystem; and critical displays were designed to be illuminated in the event of power failure by beta lighting (a radioactive light source) on numbers, graduations, and pointers.

Layout and design of electrical-electronic system C/D's presented similar problems. For example, in Fig. IIIB-15 the breakers go up for "off" on the top row but down for "off" on the lower one. In Fig. IIIB-16 there is no label on the hard-ballast display. Also, controls are poorly grouped.

Figs. IIIB-17 and IIIB-18 illustrate the redesigned C/D's for the electrical-electronic system. Once again, they are separated into functional groups and laid out in order of sequence of use.

### Conclusions

This paper discusses some of the results of a Human-Engineering Evaluation of the SDL-1 and presents improvements in design and layout of operator seating and in controls and displays associated with some aspects of vehicle operation. The redesign represents a great improvement over the original version. Action is being taken in the format of a product improvement program where the most critical modifications are being considered first.



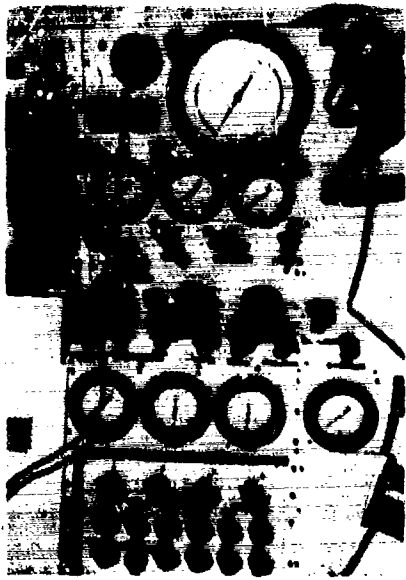

Fig. IIIB-13. Fitted life support control displays.

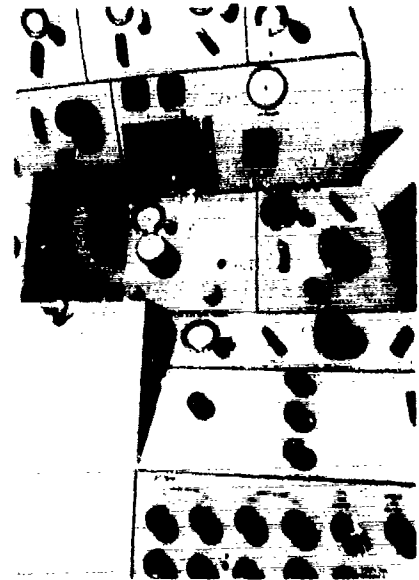

Fig. IIIB-14. DCIEM life support control displays.

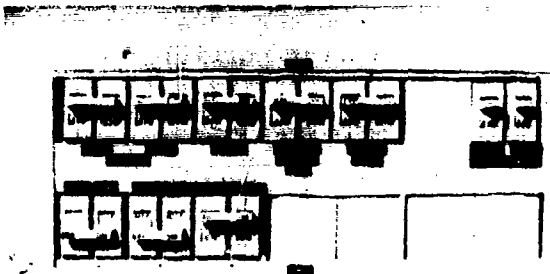

Fig. IIIB-15. Fitted breaker panel 120 VDC.

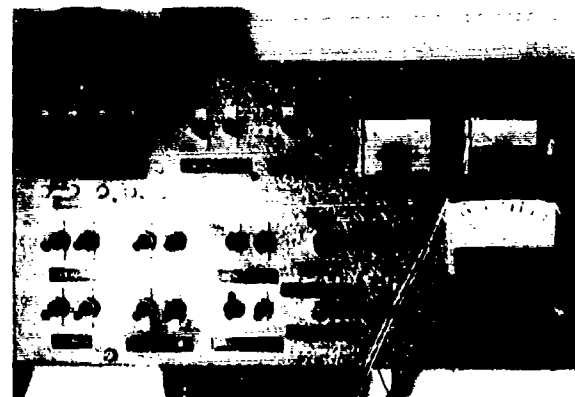

Fig. IIIB-16. Fitted breaker panel 12/28 VDC.

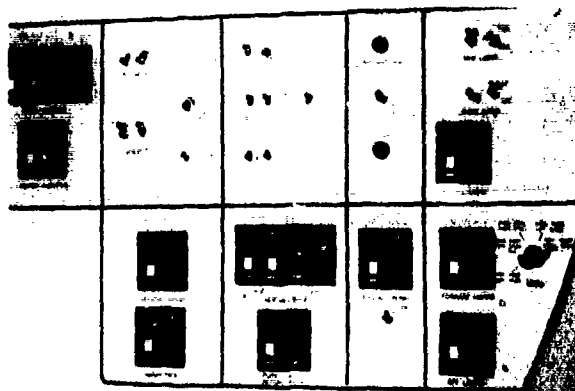

Fig. IIIB-17. DCIEM breaker panel.

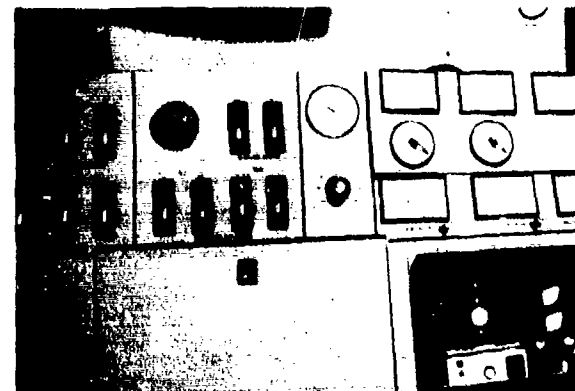

Fig. IIIB-18. DCIEM electronic-electric S/W panel.

## SUMMARY OF DISCUSSION

The question of free-ascent training for DSV operators was raised. The point was made that most divers are not trained in free ascent and that the hazards associated with this procedure are such that it should be dropped as a standard training procedure. It was considered more important to get escape procedures established and related to the crew than to train in a hazardous environment.

Discussion of available, standard education and training aids within the US Navy for DSV application was held. It was felt that such equipment does exist and could be utilized to this end. One example is the crises-analysis test for screening DSV crew members. This is a 40-50 item questionnaire withing a standard format. Answers indicate the likelihood of specific types of behavior on the part of the candidate, some of which may lead to accidents. The questions are quite standard and can be given prior to a routine annual physical. When indicated, a follow-up interview by a physician can be held to predict stressful behavior. The psychiatric interview procedures currently in use are extremely vague and ambiguous. The MTS psychiatric interview is a limited screening effort which does not threaten the operator.

The use of existing US Navy DSV training devices in the area of behavioral research was reviewed. It was felt that their use might be desirable, but some apprehension was voiced by non-Navy personnel as to the added requirements which might be generated. It was felt that stricter certification requirements could spill over from the Navy to private industry and further constrain their activity.

The question of age was discussed. At present, the more complex boats are driven by older men, some in their 50's. It was felt that as the missions of the boats change, so will age of the pilots. With longer dives of greater frequency and risk, younger men will be required. While all dives start out routinely, they may become prolonged due to accident or malfunction. A different set of problems, particularly with older men involved, might result.

The general opinion was that a good pilot need not necessarily be Navy submarine qualified. The point was also made that qualified DSV pilots should be able to remain in this type of duty for longer periods of time without endangering their careers. The Canadians have attempted to solve this problem of rotation by using divers as pilots and crew members thereby combining both of these subspecialties within the submersible work area. The confidence level of the overall system appears to be upgraded by the knowledge that the operators appreciate the lock-out divers' problems by having also been out there themselves. This system of rotation makes for a fairly good career pattern, and results in a higher lever of expertise. It was suggested, however, that in sophisticated vehicles like DEEP QUEST, divers may not be able to handle the extremely complex systems.

There is a common complaint among divers in the US Navy that they do not have the opportunity to work in their rate. It is well-known that advancement through the rating structure is dependent on rating proficiency. Therefore submersibles may be more attractive to divers because it may give them a chance to work in rate.

The needs of this specialty area dictate the employment of young, experienced people who are career oriented and have training in confined spaces. At present the submarine force represents a pool from which to draw. With the current energy-resource search around the world, a proliferation of submersible and diving systems is taking place. The level of experience and training of the people who will run and maintain these systems will probably be much lower than in the systems used in the recent past.

The general impression of the commercial diving industry which involves diver-sub operations was that insufficient time is given to emergency training. An assessment should be made of the kinds of training needed, the amount of refresher training needed, and the type of physical fitness needed.

No formal program in the US Navy or industry exists to ensure that such training occurs. The Canadian Forces test their people periodically to monitor the level of their conditioning. If they do not measure up or maintain the proper level, they are given compulsory physical education until they do.

## CONCLUSIONS AND RECOMMENDATIONS

1. Many deep submergence vehicles have been designed and fabricated with a limited approach in the area of human engineering.
2. To avoid the inconvenience and hazards caused by restricted vision and poor equipment design and layout, human engineering evaluations should routinely be conducted on all existing and future proposed deep-submergence vehicles.
3. Standard concepts of training and education should be integrated into the deep submergence vehicle field to avoid the chance assembly of curriculum materials by personnel who are operationally experienced, but untrained as educators.
4. Free-ascent training should be discouraged particularly for the small submersible operator.
5. Deep submergence vehicle systems represent unique environments in which valuable behavioral data can be collected.
6. As vehicle missions become longer, more frequent, and more hazardous, younger persons will be required.
7. The requirement that a submersible pilot be a Navy-qualified submariner should be dropped. Divers should be considered for integration into these systems, particularly if they are lock-out boats.
8. Physical conditioning should be a vital part of the overall training procedures as applied to these systems. Fitness should be monitored and appropriate level maintained.
9. An assessment should be made of the kinds of emergency training needed, the frequency of repetition, and the use of teaching aids.
10. Procedures and standards for both the Navy and civilian DSV communities are often not well-defined or regulated. Techniques presently used in selecting for comparable situations could be applied to DSV personnel selection.
11. DSV operations could serve as a testbed for additional psychological screening and selection techniques for the mutual benefit of both the DSVs and related systems. Research problems might include the psychological effects of isolation, small group interactions, fatigue, visual-perceptual abilities, and performance (control) effects related to vestibular disturbances.
12. Current training objectives are not well-defined in terms of measurable performance.

13. More use should be made of available training technologies to objectify the DSV training situation, and to redesign training programs.

14. The identification and improvement of some DSV training problems will depend on the degree to which such efforts can be applied to other comparable systems.

15. Critical training problem areas include the use of simulators and mock-ups, maintenance training, crew-task interactions, cross training, and training for remote-control operations.

## SESSION IV: UNIQUE VEHICLES

### A. DIVERSUBS, AN OVERVIEW: DR. J. MacINNIS

In 1967 an unusual small submersible was launched in the United States. DEEP DIVER, a lock-out submersible or diversub, was the world's first vehicle built expressly for transporting divers to the deep edge of the continental shelf. Since that time four additional diversubs have been constructed and eight others are in various stages of planning, lay-up, or construction. Future support of manned undersea activities will include an increasing number of diversubs. Accelerated interest in deep commercial and scientific operations insures the development of larger diversubs having longer duration. It is likely that a combination of diversub and the articulated armored suit will be developed in the near future to overcome the physiological limits of deep diving man.

#### Background

This paper is a review of the concepts that led to the development of the lock-out submersible or diversub. The primary framework of the conceptual progression is given Fig. IVA-1:

#### DIVERSUBS: AN OVERVIEW

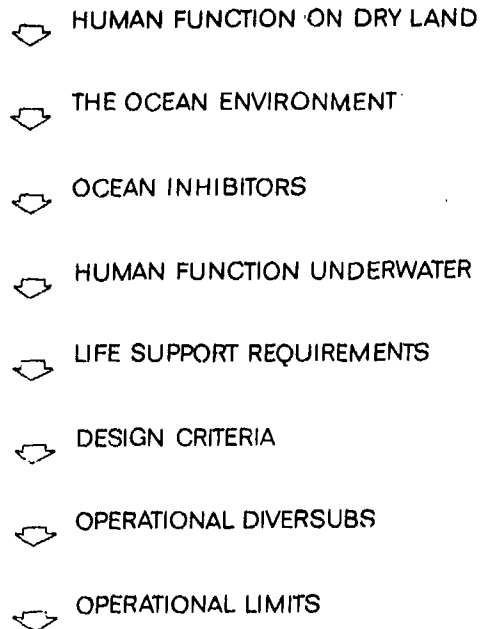

THE FUTURE

Fig. IVA-1. Diversubs: an overview.

Man has operated his sensory and motor modalities more or less successfully on dry land for thousands of years. Until recently, the severe physical, chemical, and biological hazards of the ocean environment have prevented him from making deep and prolonged excursions into the sea. In the last decade with the advent of deep, short-duration, and saturation diving, the array of ocean inhibitors or stressors has been clearly demarcated. Repeated laboratory and open-sea exposures, particularly in Europe and North America, attempted to overcome the multiple obstacles that exist. All of the programs which measured human physiology and performance concurred that man's performance underwater is rarely as efficient as it is on the surface. Its decrement is a function of depth, darkness, heat loss, and many other factors.

A series of life-support and work-support requirements have been drawn up to support man beneath the sea. One of the most effective systems to be designed to meet these requirements is the diversub. It was designed to extend the capability of the submersible decompression chamber and to allow the diver transportation to and from the work site.

### HUMAN FUNCTION ON DRY LAND

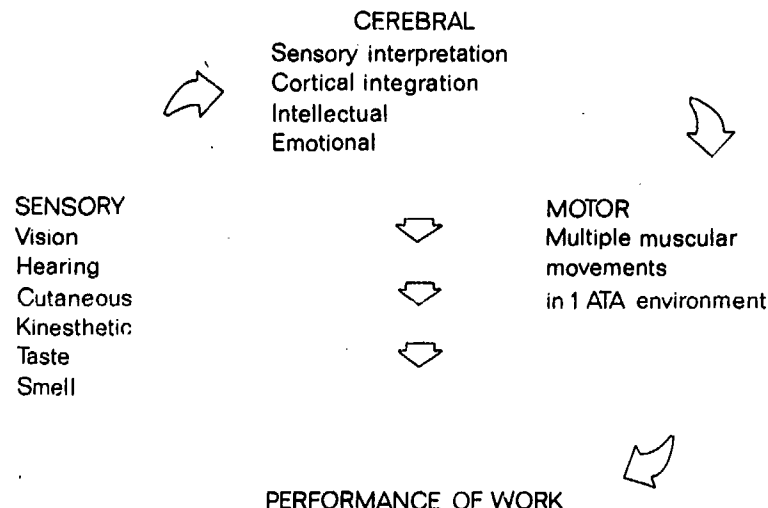

Fig. IVA-2. Human function on dry land.

Some highlights of human function on dry land are found in Fig. IVA-2. All students of physiology understand the complex mechanisms and interactions that occur between sensory and motor modalities. A major difference between land and sea is that work tasks on land are part of active responses developed over centuries of time. Only in the past 10 years have humans worked deep within the sea for prolonged periods. There is much to learn about improving performance adaptation.

Several reasons for the inefficiency of manned underwater performance are seen in Fig. IVA-3. Problems of temperature, density, currents, darkness, and pressure have been studied for decades. Recent underwater activities in the polar regions force the acceptance of even greater decrements in underwater performance. Elements such as wind, snow, and ice severely constrict

# THE OCEAN ENVIRONMENT

WIND · RAIN · SNOW · HAIL

SFA-STATE                      ICE

TEMPERATURE

                    DENSITY

                            CUPRENTS

                                    DARKNESS

    PRESSURE

    MARINE LIFE

    SEDIMENTS

    BUOYANCY

    BOTTOM CONDITIONS

Fig. IVA-3. The ocean environment.

performance, exerting continuous and significant demands in fatigue and anxiety.

The factors inhibiting successful human performance beneath the sea are attributable to the water and gas which surround and contain the diver (Fig. IVA-4). Exposure to water leads to cold, decreased mobility, and fatigue. It also leads to decreased acuity, voice communication, muscle power, touch, and cerebation. Exposure to breathing gas mixtures leads to increased respiratory work, speech impairment, cold, narcosis, and, at greater depths, the high pressure nervous syndrome. In addition it can lead to that most protean of underwater problems, dysbarism.

## The First Diversub

The overwhelming nature of ocean inhibitors and man's diminished performance when exposed to them led to the 1962 development of Edwin Link's submersible decompression chamber or SDC. Five years later Link's dissatisfaction with the restricted two-dimensional mobility of the SDC led to the construction of DEEP DIVER, the world's first operational diversub.

When considering the support requirements for this and the other diversubs which were to follow, both life support and work support had to be considered. (See Fig. IVA-5). Life support means strict control of breathing gas, diving compartment temperature, diver communication, and all aspects of refuge such as egress from and entry into the diving compartment. The objective of life support is to decrease life threatening situations and to minimize stress. Diminishing diver anxiety means a parallel decrease in accident potential.

Another major consideration is work support. Attention must be given



## OCEAN INHIBITORS

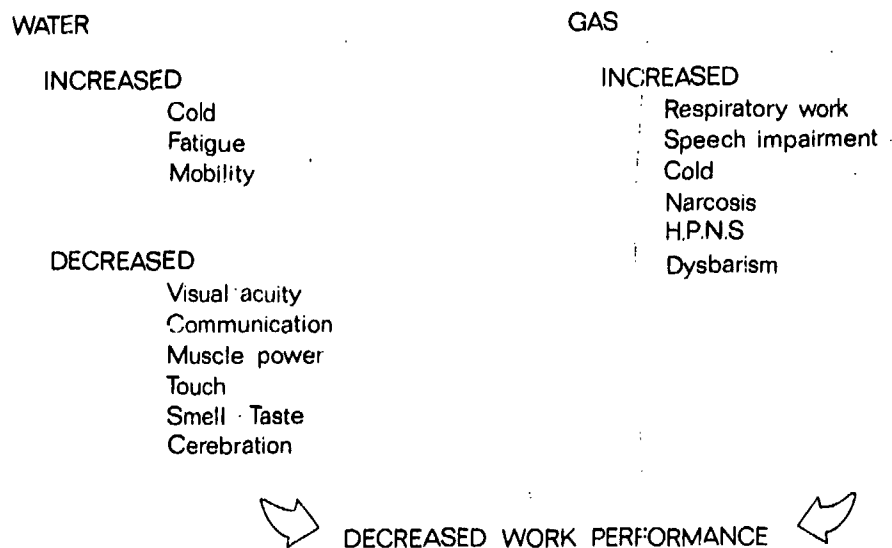

Fig. IVA-4. Ocean inhibitors.

to the ease of transport to the dive site, the ability to "light" the work area and the development of exterior and interior television and camera systems to document the work in process. Other work support systems, such as manipulators, water jets, and coring and cutting systems soon evolved. Today, one of the most important functions of diversubs is the rapid and effective survey of sea-floor pipe lines.

### DIVERSUB: SUPPORT REQUIREMENTS

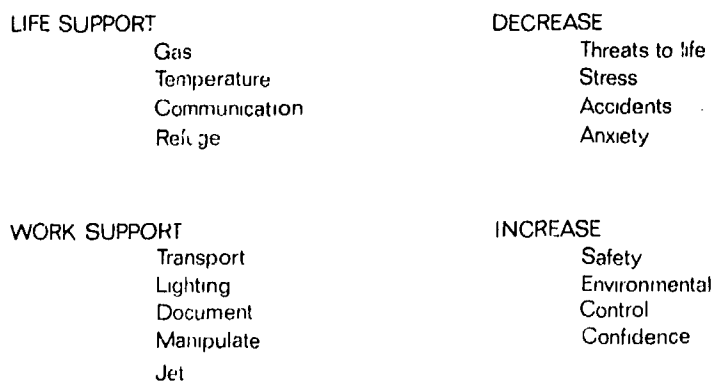

Fig. IVA-5. Diversub: support requirements.

Some design criteria for diversubs are listed in Fig. IVA-6. Life support for divers focuses on several factors. Primary among these is oxygen partial pressure which, depending on the nature of the dive, can range between 0.3 to 1.2 ATA. The capability to deliver 100% oxygen is often required for the last phases of decompression. Carbon dioxide levels are usually maintained

at levels less than 7 mm of HG. Specific control analysis and display of this information will be dealt with in another paper in this symposium. To date, the only background gas used in diversubs has been nitrogen and helium. It is likely that future open-sea operations will be conducted using hydrogen and neon. In the past, good diver to pilot communication has existed in all diversubs. Analysis of recent activities suggests that consideration should be given to installing direct diver-to-surface communication in the event of a malfunction of the forward communications link.

## DIVERSUB: DESIGN CRITERIA

### LIFE SUPPORT

O <sub>2</sub>	0.3 - 1.2 ATA & 100%
CO <sub>2</sub>	< 7mm Hg
Inert gas	N <sub>2</sub> - He
Fire control	
Communication	diver - pilot - surface
Temperature	normal skin and core

### WORK SUPPORT

- Proximetry to site
- Carrying capacity
- Lighting
- Manipulator
- Jetting
- Tools
- Documentation

Fig. IVA-6. Diversub: design criteria.

Power and payload limitations mean that one of the most serious life support problems is to maintain an adequate temperature within the diving compartment. The most common complaint from divers during operations conducted from diversubs is that of cold. At present, existing insulation and power capability are not adequate to heat the entire after compartment, but attention must be directed to providing sufficient energy to the diver's suit and/or his breathing apparatus. It is an area meriting serious engineering research.

### Operational diversubs 1974

A list of operational and planned diversubs is found in Table IVA-1.

SHELF DIVER, fabricated by Perry in the United States, was constructed in 1968. It has carried out more lock-out dives than all of the other diversubs, transporting a payload of 1000 lb or two divers and their supporting gear to a maximum depth of 800 ft. It has worked extensively in tropic and temperate waters around the world.

SDL-1 was fabricated in 1971 by Hyco for the Canadian Maritime Forces. Presently it is depth-limited to 150 ft for lock-out dives. With the

anticipated arrival of the deck decompression chamber complex, SDL-I will be able to support lock-out dives to 1000 ft. It is currently based in Halifax where it is undergoing a series of tests and operational dives.

The JOHNSON-SEA-LINK is operated by the Harbor Branch Foundation in the United States. It was built in 1972 and has carried out approximately 150 lock-out dives to date. This diversub has a maximum depth capability of 1200 ft with a payload of two divers or 1000 lb. Its most important feature is

Table IVA-1. Diversubs: 1974

		FIRST DIVE	NUMBER OF DIVES	MAX. DIVER DEPTH (FEET)	PAYLOAD (LBS)
SHELF-DIVER	U. S.	1968	500	800	1,000
SDL-1	CANADA	1971	250	1,000	2,500
SEA-LINK	U. S.	1972	150	1,200	1,000
VOL-L1	U. K.	1973	50	1,200	2,000
DEEP DIVER	U. S.	1967	500	1,250	1,500
PC-17	U. S.	1976		2,000	1,500
TAURUS	CANADA	1976		1,200	4,000
PH 66	ITALY	1977		1,000	
URF	SWEDEN	1977		1,000	
UNNAMED	JAPAN	1978		1,000	
ARGYRONETE	FRANCE			2,000	
TINRO I	USSR				

that it allows a panoramic view from the forward sphere. The rest of the vessel, except for the viewports in the after sphere, is made of aluminum.

The VOL-L1 was constructed by Perry for Vickers Oceanautics in the U. K. Built in 1973, it has, by 1974, carried out some 50 lock-out dives. It has a 1200 ft depth capability and a payload of 2000 lb. It will be used extensively in the North Sea for pipe line survey and inspection.

There are eight diversubs in the planning or inoperative stages. DEEP

DIVER has served its owners since 1968 and is being turned over to the Smithsonian Institution in Washington. PC-17 is planned by Perry for delivery in 1976. It will have a maximum depth of 2000 ft and a payload of 1500 lb. TAURUS is planned by Hyco for 1976. It will have a depth capability of 1200 ft and a payload of 4000 lb. SSOS in Italy has plans to operate a diversub called PH 66 in 1977. It is an unusual vessel and is designed to carry seven divers for 7 days over a 400-mile range. Present engineering efforts are concentrated on providing a closed-circuit diesel power plant. This diversub will have an operating depth of 1000 ft.

The Swedish Navy plans to launch its undersea rescue vehicle URF in 1977. Its function is primarily to provide rescue for 26 men. However, this diversub has the capability of carrying two lock-out divers to a depth of 1000 ft. It is being designed and built by COMEX and KOCKUMS. As part of its ocean science and technology program, Japan plans to launch a diversub in 1978. This as yet unnamed vessel will have a maximum lock-out depth of 1000 ft. Construction of the French ARGYRONETE was started in the last decade and halted due to lack of funds. It is a large diversub with a lock-out depth of 2000 ft. There are no plans to continue construction. Although details are sketchy the Russians appear to be planning a submersible with the name of TINRO I. At the time of writing the lock-out capability of this vessel was still in question.

An outline of some operational limits is given in Fig. IVA-7.

## OPERATIONAL LIMITS

DEPTH  
DURATION  
DIVERS  
PAYLOAD

TEMPERATURE CONTROL  
DECK CHAMBER  
LAUNCH AND RECOVERY

POWER  
SUPPORT VESSEL

Fig. IVA-7. Operational limits.

The deepest lock-out dive to date has been a 700-ft, 30-min excursion made from DEEP DIVER in 1968. Current lock-out depths average less than 300 ft. However, it is likely that depths of 1000 to 1500 ft will be commonplace within the next 5 years. The biggest constraint on diversubs relates to their limited energy payload. Limited power output constricts both speed and duration. All vehicles have so far been equipped with lead acid batteries, but

consideration is being given to more exotic designs such as fuel cells and closed circuit diesel systems.

In the near term, it is likely that diversubs will carry only two divers. Manned undersea work indicates that paired teams are optimal for most deep work objectives. As mentioned before, temperature control of the diving chamber is one of the most seriously limiting obstacles.

Diversub operations are greatly extended with the addition of a surface chamber. Canada's SDL-I is an example of a severely constrained diversub awaiting a deck chamber to enlarge its capability. It has long been recognized that a diversub by itself is only part of a complete system. The support vessel and its launch and recovery system must operate as an integrated unit. Again, the SDL-I is an example of a diversub urgently requiring an adequate surface support vessel and launch and recovery system.

### The Future

Some possible future trends of diversubs are indicated in Fig. IVA-8.

### THE FUTURE

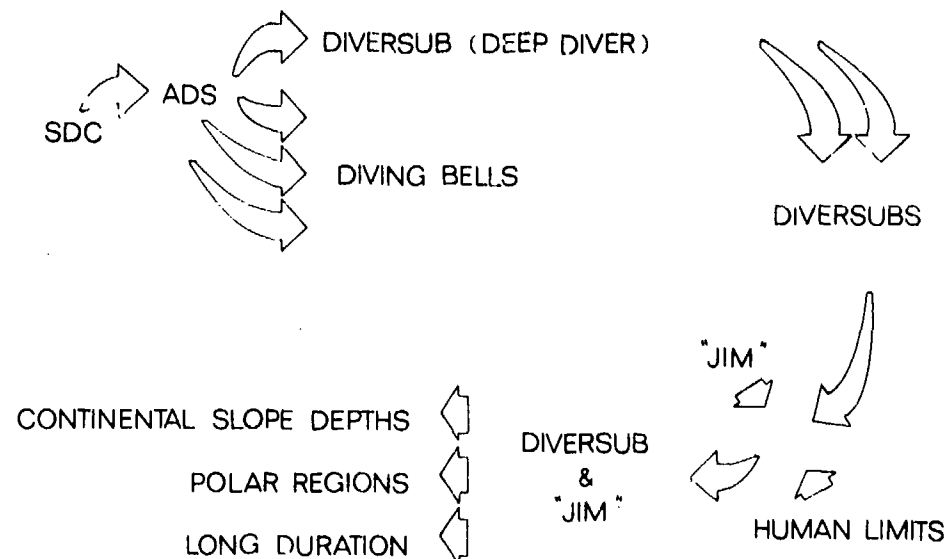

Fig. IVA-8. The future of diversubs.

Following the development of the submersible decompression chamber in 1962, a modification called the Advanced Diving System (ADS) was made by Ocean Systems. The basic design of this spherical chamber was married to a submarine hull and became the prototype diversub DEEP DIVER, which began operations in 1967. By 1968 it had demonstrated that the diversub could support working men to depths of 700 ft. During this same period, diving bells (which now number in excess of 250) were being widely manufactured. The parallel success of DEEP DIVER spawned the development of several other diversubs.

The future evolution of diversubs will be affected by several factors. One of the most important is the work undertaken to determine the psychophysiological limits of man under pressure. Indications are that somewhere between 2000 and 3000 ft, the human system will be incapable of effective work. Others have argued that the cost-benefit of the working diver at these depths will preclude his use.

Another influence on the future of diversubs is the development of the anthropomorphic submarine or 1-atm diving suit, known as JIM. It is this author's opinion that a diversub will be developed that will transport JIM, or some future kin, into the ocean depths.

Whatever the design and operation of tomorrow's diversubs, it is certain that these novel systems will be built in increasing numbers for greater depths and duration. They will continue to operate in support of commercial diving operations related to oil and gas and will be built to operate beneath the polar ice. There will be an increasing call on diversubs to support marine science studies.

B. CANADIAN FORCES (SUBMERSIBLE DIVER LOCKOUT ONE): LCDR J. COLE, CF

SDL-1 is owned by the Canadian Armed Forces and operated by the SDL Detachment of the Fleet Diving Unit Atlantic from Halifax, Nova Scotia. SDL-1 is certified to operate to a maximum depth of 2000 ft and is constructed to provide a 1000-ft diver lock-out capability. At present lock-out diving is limited to 150 ft due to the lack of a deck decompression complex. However, a fully equipped deep-diving tender designed to act as the support ship for SDL-1 is nearing completion.

The submersible consists of the control sphere, connecting tunnel, and the lock-out sphere. It is 25 ft long, 10 ft in beam, 12 ft high and weighs 30,000 lb. Life support is sufficient for 204 man hours. All external equipment such as the torpedo claw, manipulator arm, lead ballast weights, and even the thruster motors are jettisonable. SDL-1 is road and sea transportable and air transportable via Hercules aircraft. Launch and recovery is conducted using a surface swimmer who disconnects/connects a snap hook to the main lifting frame just aft of the sail.

Pressurization of the lock-out sphere can be done either by the diving supervisor in the lock-out sphere or by the copilot in the control sphere. When the lock-out sphere reaches ambient pressure the lower hatch opens. The divers then fill soft ballast tanks with seawater making the lock-out sphere 400 lb negatively buoyant. The first diver steps out and attempts to lift the submersible. If unable to, he grasps his umbilical hose and connects up. Leaving the sphere, the diver uncoils his umbilical hose and proceeds to his work, which is in front of and illuminated by the control sphere. Currently we use the Bandmask and Unisuit with the SUBCOM Round Robin communications equipment.

The most important components of SDL-1 are: Biomarine O<sub>2</sub> monitor controller 104; Biomarine O<sub>2</sub> sensors; Airco CO<sub>2</sub> scrubbers using Dragasorb; Drager and Beckman Minos CO<sub>2</sub> monitors; 120V, 12V, and 28V power supplies and inverters; Amtrek Straza underwater telephone with TIPE option (transponder, interrogator, pinger, echo sounder); directional aircraft gyro; Wesmar Sonar for collision avoidance and search; Ross echo sounder; 4 quartz iodine lights.

Despite the lack of a permanent support vessel SDL-1 has successfully recovered three military aircraft and considerable research equipment. The most interesting task was the intact recovery of an Avenger aircraft discovered unexpectedly during a routine training dive. The aircraft had been ditched 20 years earlier and was found in 240 ft of water. Steel claws were devised to clamp onto the three blades of the propeller. The claws, attached to a single recovery ring, distributed the strain equally to the three blades. Each claw was spring-loaded and was designed to snap shut when placed against the propeller hub. A single nose was devised for the arrestor hook. The

aircraft was raised to the surface where additional lines were secured and then hoisted on deck. The Avenger is currently being restored as a historical display.

To date our most difficult task has been the recovery of a Sea King helicopter from a depth of 660 ft. When located, 30 miles off the coast, it was found to be lying upside down. A recovery sling and clamps were devised and placed on the wheel sponsons. Taking the lift line down on our reel--a home-made attachment used in lieu of our torpedo claw--it was secured to the recovery sling. As the SDL-1 returned to the surface the lift line unreeled and was passed to the barge. The helo was then hoisted onboard.

With our new deep-diving tender, operations can be conducted to ever increasing depths on the ocean floor utilizing saturation diving techniques and the deck decompression complex. This may even include working with undersea habitats on the continental shelf.



C. U. S. NAVY DEEP SUBMERGENCE RESCUE VEHICLE: LCDR K. GREENE, MC, USN

The primary mission of the Deep Submergence Rescue Vehicle (DSRV) is to provide a quick-reaction capability to rescue personnel from a disabled submarine. The U. S. Navy Deep Submergence Rescue System includes two DSRVs, a Rescue Unit Homeport (in San Diego), two ASR-21 Class Submarine Rescue Ships, and a number of specifically configured Mother Submarines. The two DSRVs are currently undergoing their operational and technical evaluation at Submarine Development Group One. The prime contractor for the DSRV is the Lockheed Missiles and Space Company.

Briefly, the Rescue System functions as follows: upon receipt of deployment orders, the DSRV is transported from the Homeport to the designated support ship, either directly by land on its Land Transport Vehicle or via C-141 military aircraft. Upon arrival at the designated port nearest the location of the distressed submarine, the DSRV and its support equipment are loaded aboard a Mother Submarine, ASR, or ship of opportunity. Upon reaching the rescue site aboard the support ship, the DSRV is launched, piloted to the distressed submarine, and mated to the escape hatch, in as many round trips as necessary to remove all survivors and deliver them to the support ship. When operating with the ASR, personnel exit takes place with the DSRV hoisted aboard. With a Mother Submarine, the rescues and the crew transfer into the forward room through the escape hatch in a submerged mating similar to the rescue mating.

The DSRV can carry up to 24 rescues at one time. Thus the rescue of the entire crew of a large nuclear submarine could require as many as seven or more trips. Each round trip would require several hours plus an hour or more turnaround time at the support ship for battery charging, life support replenishment, and reballasting. The DSRV can mate with most modern submarines. The exact requirements for compatible mating surfaces have been distributed to interested foreign navies. Mating can be accomplished at angles of up to 45°.

Vehicle Description

IVC-1 illustrates the general configuration of the vehicle; specifications are summarized in Table IVC-1. The pressure hull consists of three interconnected 90" speres of HY-140 steel, with an operating depth rating of 5000 fsw. A free-flooding fiberglass fairing covers the pressure hull and external equipment such as batteries, hydraulic systems, and ballast systems. Syntactic foam sections are contained under this "skin" to add buoyancy. The principal load-bearing structure is a framework of titanium and aluminum members. Total submerged displacement is 75,000 lb. Length overall is 49.3 ft.

Electrical power is provided by two 112-V silver-zinc batteries, plus a 28-V emergency battery. The main batteries are rated at 58 kilowatt-hours at a 5-hr rate and are sufficient for 5 or more hours of normal submerged

operations. Cruising power for speeds up to 4.1 knots is provided by the main propulsion unit with a three-bladed propeller. The steering shroud controls both yaw and pitch. At low speeds, four ducted thruster units are used to achieve control of yaw, pitch, heave, and sway. The DSRV can hover in currents up to 1 knot athwartships. The sixth degree of freedom, roll, is controlled by a mercury ballast system, which can also be used to set and hold angles of pitch up to 45°.

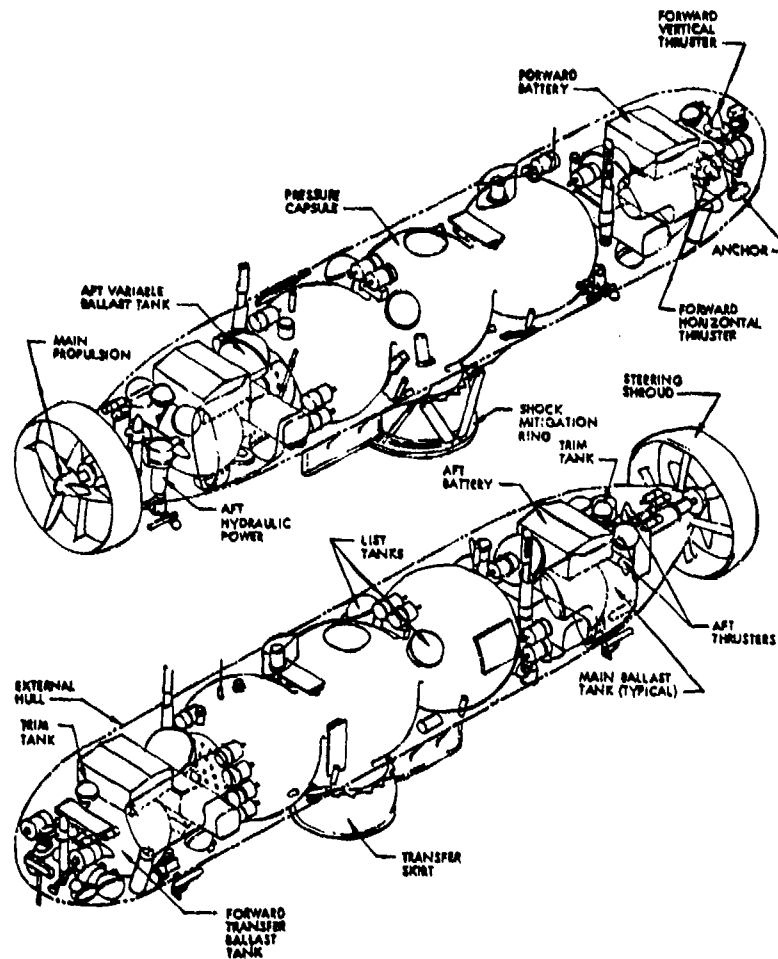

Fig. IVC-1. DSRV configuration (from Preliminary technical manual for DSRV vehicle subsystem).

The main ballast system provides 6400 lb of buoyancy for surface operation. A hard-tank variable ballast system is used to compensate for depth-induced changes in buoyancy. This system utilizes a hydraulic-powered high pressure pump. The transfer ballast system is another hard-tank system which accepts the water pumped from the transfer skirt during the mating operation. A trim and list system containing about 3000 lb of mercury is used to establish and hold angles of roll or pitch up to 45°. The entire contents of the mercury system can be jettisoned for emergency deballasting in the event of hard-tank flooding in one of the other ballast systems. Finally, seven collapsible

containers inside the mid and aft pressure spheres hold 4080 lb of water. A quantity of this water is drained into the disabled submarine to compensate for the weight of the rescuees accepted.

Table IVC-1. DSRV characteristics  
(from Preliminary technical manual for DSRV vehicle subsystem).

---

Displacement (submerged)	75,750 lbs.
Length overall	49 ft. 4 in.
Outer hull diameter	8 ft. 2 in.
Height (with skirt)	11 ft. 8 in.
Pressure hull:	
Three spheres, each	7 ft. 8 in. O.D.
Basic membrane thickness	0.738 in.
Personnel capacity:	
Control sphere	2
Mid sphere	13
Aft sphere	13
Depth rating	5000 fsw
Internal pressure capability:	
Control sphere	0.8 to 3.7 ATA
Rescuee spheres	0.8 to 5.0 ATA
Vehicle speed:	
Cruise	4.1 knots
Towed	5 knots (max.)
"Piggyback" on Mother Sub, submerged	15 knots
Ballast:	
Main	6400 lbs.
Variable	1400 lbs.
Transfer	5664 lbs.
Rescuee	4080 lbs.
Mercury	2918 lbs. (DSRV-1) 2710 lbs. (DSRV-2)

---

The elaborate navigation and sensor systems are designed to provide accurate position keeping, and both long- and short-range search and obstacle avoidance capability. Navigation data are processed by a computer system and presented at the Integrated Control and Display Panel. Navigation input is received from an inertial navigator, Doppler sonar, depth transducers, and tracking transponders. Horizontal obstacle avoidance sonar is also used, along with pan-and-tilt television cameras and viewport vision with remote optics.

The underwater mating system allows the transfer of rescuees from the distressed submarine to the midsphere of the DSRV. The final approach to the forward or after escape hatch is aided by a short-range sonar and TV camera located in the transfer skirt. A hydraulically damped and retractable shock mitigation ring protects the skirt mating surface from collision damage.

If the mating surface is fouled, a water jet and grip device on the hydraulically actuated manipulator may be used to clear it. A cable cutter is used to remove the messenger buoy cable which would be attached to most escape hatches. When a firm seat is established, a sea water pump in the skirt creates a 15-psi differential pressure between the skirt and the sea to make the seal. Skirt pressure is then equalized with the transfer ballast tanks (at 1 ATA) and the air in the tanks is exchanged by a pump for the water in the skirt. Then the full sea pressure of the depth holds the transfer skirt against the hull surface around the escape hatch. Four hold-down turnbuckles may be used for added security in shallow rescues or for the transfer to the Mother Submarine.

After discharge of the rescuee ballast and the transfer of up to 24 persons (weighing up to 4080 lb), and after closing both the DSRV and submarine hatches, the transfer ballast is pumped back into the skirt. The skirt pressure is then equalized to sea to allow the seal to be broken. The DSRV transfers the rescuees to the Mother Submarine by a repeat of the mating process or, if the support ship is an ASR, release them on deck. Resupply and recharging of the DSRV can also be carried out by either method.

The streamlined form of the DSRV protects against fouling and entrapment. The manipulator and pan-and-tilt units can be jettisoned by pyrotechnic devices if entangled.

#### Medical Considerations

Because the DSRV may carry as many as 28 persons, the life support requirements are formidable. Each sphere has an independent system. The compartment atmosphere is circulated by blowers through heat exchangers and scrubber canisters. In the mid and aft spheres, heat is dissipated through heat exchangers bonded to the internal surface of the hull, which is otherwise fully insulated. Condensate is collected from these exchangers, and an auxiliary portable dehumidifier is also provided. In cold water operations, heat may be added by electrical resistance heaters. In the control sphere, where electrical equipment heat load is great, a separate circulation and heat exchange system cools the equipment. A self-contained freon refrigeration unit boosts the capacity of this system.

Oxygen is stored in 380-cubic inch, 3000-psi, removable tanks. It is reduced to 10 psi over compartment pressure and added to the atmosphere either automatically or manually. Polarographic  $PO_2$  sensors are used to monitor and control this system. The set point for the automatic mode is 160 mm Hg  $\pm$  20; high and low alarms are provided. Carbon dioxide removal depends on scrubbing the atmosphere through disposable cartridges containing 4 lb of pelletized lithium hydroxide plus activated charcoal and filter material. The control sphere system uses two cartridges in parallel; the mid and aft spheres each use three. Carbon dioxide partial pressure is nominally kept below 6 mm Hg and is monitored with polarographic sensors. At compartment internal pressure up to 5 ATA, decreased blower sufficiency may theoretically cause a rise to 12 mm Hg (Li and Sudolnik 1970).

The mission of the DSRV requires an elaborate emergency breathing system (EBS) because of the number of passengers, the likelihood of sharing a contaminated atmosphere with the distressed submarine, and the potential for operating at positive pressure. The control and rescuee spheres each have independent but similar systems. The EBS is of closed-circuit design using nitrogen as the diluent gas. The total system pressure is kept at 2 inches of water over ambient to minimize contamination. Oxygen partial pressure is automatically or manually made up to 160 mm Hg  $\pm$  20, as measured by polarographic sensors. Sensors also monitor PCO<sub>2</sub> system incorporates double-hose, full-face masks, breathing bags in the manifolds, and the same type of LiOH cartridges as the compartment atmosphere system. The control sphere EBS uses one cartridge; each of the rescuee spheres has two. At increased compartment pressure, the EBS is maintained normoxic by addition of nitrogen from a 3000-psi tank. The design enables 28 persons to breathe on the EBS with minimal rise of compartment pressure by mask leakage. In a 2-hour test with 13 men breathing on the EBS in the aft sphere, compartment pressure increased by less than 2 psi (Lockheed Missiles and Space Co. 1971). The use of an open-circuit system in this setting would theoretically have increased the compartment pressure to 3.5 ATA or more.

With only the pilot and copilot aboard, the entire vehicle's supply of O<sub>2</sub> and LiOH would provide them with an endurance of 2 weeks. A full load of 24 rescuees plus the mid and aft sphere crewmen would add 26 men, and this defines the minimal endurance of the life support systems. Tables IVC-2 and IVC-3 list oxygen supply and CO<sub>2</sub> -scrubbing capacity data. The contractor specifies a nominal 24 man-hours for each 45-scf oxygen tank (Preliminary Technical Manual for DSRV Vehicle Subsystem 1970, Li and Sudolnik 1970). This corresponds to an oxygen consumption rate of about

Table IVC-2.

Oxygen supply available in the control, mid, and aft spheres

	OXYGEN SUPPLY		
	Control	Mid	Aft
O <sub>2</sub> (scf)	90	135	135
Man-hours (nominal)	48	72-135	72-135
Duration (hours)	24	5.5-13.4	5.5-13.4

0.9 liter/min per man. At this rate, the endurance for a full load would be 5.5 hr (considering the control-sphere supplies unavailable to the rescuee spheres). If a resting rate of 0.5 liter/min, or 1 scf/hr, is assumed, the endurance would be about 10 hr. A 13-hr test with 13 men seated in the aft sphere has demonstrated a consumption rate which would give an endurance of

13.4 hr (Lockheed Missiles and Space Co. 1971). This endurance would be required only in the highly unlikely event of entrapment following completion of a successful mating operation.

Table IVC-3.  
Carbon dioxide scrubbing capacity in control, mid, and aft spheres

	CO <sub>2</sub> SCRUBBING		
	Control	Mid	Aft
Total LiOH (lb)	27.7	51.5	51.5
CO <sub>2</sub> capacity Theoretical (scf)	205	381	381
Nominal man-hours	84	156	156
Duration (hours)	42	12	12

The theoretical CO<sub>2</sub>-combining capacity of each 4-lb LiOH cartridge is about 29 scf, or 36 man-hours. The nominal rating in this life support system is 12 man-hours per cartridge (Preliminary Technical Manual for DSRV Vehicle Subsystem 1970, Li and Sudolnik 1970). At this rate the full-load endurance would be 12 hours. In the 13-hour test mentioned previously (Lockheed Missiles and Space Co. 1971) cartridges were changed at intervals corresponding to 13-man-hour ratings, and the compartment PCO<sub>2</sub> did not rise above 7 mm Hg. This would correspond to a total endurance of 13 hr.

One area is of particular interest: the several consequences of operation at positive pressure. The design criteria for the DSRV specified that it should be able to equalize with the distressed submarine at pressures up to 5 ATA, and to maintain this internal pressure during transfer to the Mother Submarine or to the Deck Decompression Chamber of the ASR. This capability would prevent the rescues' suffering decompression sickness during the transfer. The positive pressure in the disabled submarine might come about by partial flooding, salvage air pressurization to control flooding, exhaust from open-circuit air emergency breathing equipment, or internal high-pressure air leaks. The probability of encountering increased pressure is difficult to evaluate but is worthy of consideration.

At 5-ATA internal pressure, the DSRV scrubbing and dehumidification system would be stressed but theoretically adequate (Li and Sudolnik 1970). Full-scale, full-load, manned tests have not been conducted at 5 ATA.

The narcotic effect of hyperbaric air is measurable at 5 ATA (132 fsw gauge) but not disabling. In the likely event that the submarine atmosphere is contaminated, the DSRV mid- and aft-sphere crewmen would breathe normoxic

nitrogen-oxygen from the EBS. The narcotic potency of this mixture at 5 ATA is equivalent to air at 167 fsw gauge. Exercise and elevated CO<sub>2</sub> would be expected to aggravate the narcotic effect. The Medical Department at Submarine Development Group One is currently studying this problem in chamber simulations. They have found definite deterioration of cognitive functioning but no great decrement in simple task performance. It is obvious that any unusual or emergency situation requiring judgment would be more difficult to deal with under the influence of nitrogen narcosis. If it can be shown that repetitive exposures produce adaptation of cognitive function in this setting, then it would be advisable to provide DSRV crewmen with narcosis indoctrination and training, either with hyperbaric nitrogen exposures or with nitrous oxide at equivalent sea level doses.

In the event that the rescues have been exposed to positive pressure, they may well have incurred a substantial decompression obligation. Given the time frame of the rescue operation, they must be assumed to be saturated with nitrogen for the purpose of decompression analysis. During the several hours of transit to safety in the DSRV, additional nitrogen may be taken up from the EBS mixture, if it is used. The DSRV crewmen will also build up a considerable decompression debt after one or more rescue circuits at pressure. Effects on decompression will be discussed later.

Another important potential consequence of this prolonged stay at 5 ATA is pulmonary oxygen toxicity (Greene 1974). Pulmonary effects of air saturation deeper than 60 fsw have not yet been studied. The oxygen partial pressure at 5 ATA of air is 1 ATA, and this PO<sub>2</sub> has definite pulmonary toxic effects, including death in prolonged exposures (Clark and Lambertsen 1971). From this point of view, the "worst case" would be maintenance of air-equivalent oxygen percentage in the distressed submarine. This would be likely if a small number of men occupied a large compartment and thus did not significantly reduce the PO<sub>2</sub> by consumption, or if they were breathing on an open-circuit EBS. A method of dose quantitation, the Unit Pulmonary Toxicity Dose (UPTD) developed by the Institute for Environmental Medicine (University of Pennsylvania 1970, Wright 1972), enables us to estimate the severity of pulmonary toxicity in these circumstances. Given the time scale of the rescue scenario, it is likely that the rescues will have been exposed to this environment for more than 48 hr before decompression can begin. Table IVC-4 shows the UPTD which would result from a 48-hr exposure to air at the gauge pressure indicated (Greene 1974). As a point of reference, a study by Clark and Lambertsen (1971) demonstrated severe chest pain, dyspnea, and a 9% decrease in vital capacity with an oxygen dose of 1200 UPTD. At any pressure significantly over the threshold

Table IVC-4. Predicted pulmonary oxygen toxicity doses after 48-hour exposures to air at depths up to 132 fsw.

Air depth (fsw)	80	90	100	110	120	132
PO <sub>2</sub> (ATA)	0.72	0.78	0.84	0.90	0.97	1.04
UPTD in 48 hours	1452	1777	2088	2390	2736	3070

of toxicity (0.6 ATA  $PO_2$ ), the table shows that a 48-hr exposure will exceed this reference level of symptomatic toxicity. The level of UPTD required for irreversible or fatal damage is unknown for man, but it is apparent that exposure to 5 ATA of air for more than a few days is potentially very dangerous. High levels of  $CO_2$  and other atmospheric contaminants may accelerate the pulmonary damage.

It is clear, then, that it would be desirable to decrease the oxygen partial pressure to less than 0.6 ATA in the distressed submarine or its EBS prior to rescue. The practicability of this approach is being evaluated. But certainly after rescue, the rescues should be returned to a safe  $PO_2$  as soon as possible. This has important bearing on the choice of a decompression method. Decompression on air from a 5-ATA saturation would take approximately 49 hr. The elevated  $PO_2$  of hyperbaric air would add a further 350 UPTD to the total oxygen dose during that decompression. This amount is not significant by itself but the delay in establishing a normoxic  $PO_2$  might well prevent healing and allow the stage of irreversibility to be reached.

A decompression on normoxic helium-oxygen would satisfy the need to reduce  $PO_2$  and this would be readily available in the Deck Decompression Chamber of the ASR, to which the DSRV can mate under pressure. However, there is a strong suspicion, based on standard decompression theory, that this might lead to difficulty (Greene 1974). Since helium is generally thought to be exchanged more rapidly than nitrogen, when a shift is made to oxyhelium breathing, a tissue saturated with nitrogen would build up a total inert gas tension greater than ambient pressure as helium is taken up. Fig. IVC-2 shows an example of how this would occur in the theoretical compartment with nitrogen half-time

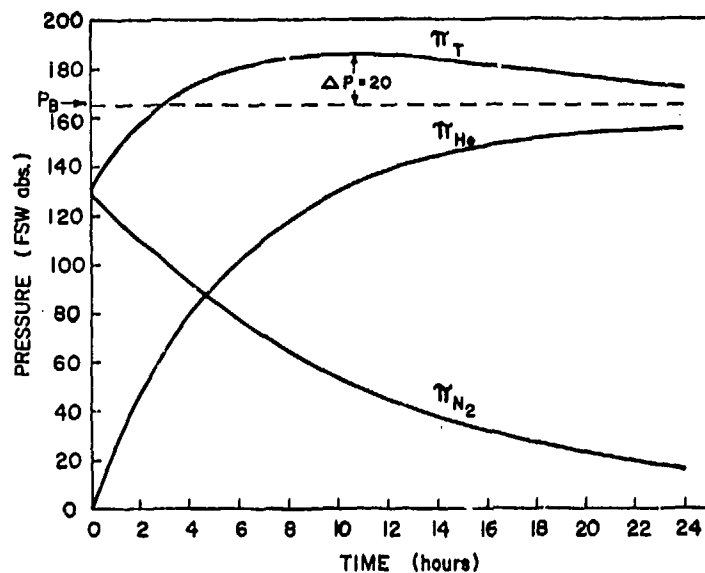

Fig. IVC-2. Supersaturation without ambient pressure change, resulting from He- $O_2$  breathing after air saturation at 132 fsw gauge.  $\pi_{N_2}$  = compartment  $N_2$  tension;  $\pi_{He}$  = He tension;  $\pi_T$  =  $\pi_{N_2}$  +  $\pi_{He}$ ; compartment has half-times of 480 min for  $N_2$  and 240 min for He.



of 480 min and helium half-time of 240 min. The initial condition is air saturation at 132 fsw gauge (165 fsw abs.), followed by normoxic oxyhelium at the same depth. The figure shows that the theoretical total compartment inert gas tension would reach a peak of 185 fsw abs. and not begin to decline until more than 10 hr after the atmosphere change. The degree of supersaturation shown in this example is in excess of the allowable  $\pi P$  for the depth, even though no change in ambient pressure has taken place. This theoretical effect could be enough to change a conservative decompression schedule into a disaster. To avoid this possible problem, the ASR diving system could be provided with a capability to operate with normoxic nitrogen-oxygen mixtures.

This capability does not exist, of course, if the decompression is to take place in the pressurized forward room of the Mother Submarine, but the need to reduce  $PO_2$  would still exist. The practicability of providing a method of doing this should be evaluated.

A number of other problems might coexist in the rescues, depending on a number of variables, and these should be listed for the sake of completeness. Some would be cured by the act of rescue; others would not. They include:  $CO_2$  intoxication, toxic effects from various other atmospheric contaminants, dehydration, starvation, immersion and cold injury, other trauma, poor sanitary conditions, psychiatric casualties, and radiation injury.

In summary, I would propose that the subject of DSRV positive pressure operation be reviewed in the light of current knowledge. Specifically, the maximum pressure considered might be more or less than 5 ATA, and this should be determined by considering anew what would be the maximum pressure we expect to find in a survivable casualty; what is the true maximum internal operating pressure for the DSRV; what is the maximum pressure and number of personnel that can be accommodated for decompression in the DDC and in the Mother Submarine; and what decompression method is to be used. A full-load test of DSRV life support function should be undertaken at this maximal pressure. The final outcome of the Submarine Development Groupe One narcosis studies should be examined to determine whether training in performance under conditions of narcosis should be instituted for DSRV crewmen.

#### REFERENCES

- Clark, J.M. and C.J. Lambertsen. Pulmonary oxygen toxicity: A review. Pharmacol. Rev. 23:37-133; 1971.
- Clark, J.M. and C.J. Lambertsen. Rate of development of pulmonary O<sub>2</sub> toxicity in man during O<sub>2</sub> breathing at 2.0 ATA. J. Appl. Physiol. 30: 739-752; 1971.
- Greene, K.M. Theoretical considerations on the decompression of reduced submarine personnel. Philadelphia, University of Pennsylvania, 1974.
- Li, Y.S. and A.J. Sudolnik. Deep Submergence Rescue Vehicle life support systems. American Institute of Aeronautics and Astronautics, Paper 70-526. Presented at A.I.A.A./Navy Marine Systems, Propulsion and ASW Meeting, Newport, R.I., May 4-5, 1970.
- Lockheed Missiles and Space Company. DSRV-1 Test Report: Life support system 24-hour manned test (LMSC-D177665). Sunnyvale, Calif., Lockheed Aircraft, 1971.
- Preliminary technical manual for DSRV vehicle subsystem, Vol.1. (NAVSHIPS 0905-120-4010). Washington, D.C., Deep Submerg. Syst. Proj. Off., 1970.
- University of Pennsylvania. Practical aspects of oxygen tolerance and oxygen toxicity. Philadelphia, Inst. Environ. Med., 1970.
- Wright, W.B. Use of the University of Pennsylvania, Institute for Environmental Medicine procedure for calculation of cumulative pulmonary oxygen toxicity. U.S. Navy Exp. Diving Unit, Rep. NEDU 1-72, 1972.

#### D. SWEDISH RESCUE CONCEPT: CAPT. A. MUREN RSN AND CDR J. ONNERMARK RSN

In the Swedish Navy submarine rescue has, during the last decades, been based on the two principal methods: group rescue with the rescue bell and individual rescue by free ascent. As for the first method, two rescue bells of the McCann type are available, one on the west coast and one in the Baltic. Since these bells are now obsolescent, it has been decided to replace them with an underwater rescue vehicle (URF). The main requirements of this vessel are: capability of rescuing the total crew of a submarine down to a depth of 300 m under normal pressure; facilities for lock-out of two divers at this depth; and capability of rescuing a submarine crew exposed to an air pressure of 10 ATA.

Since only about 3 million dollars were available for this project, the vehicle would necessarily not be a very sophisticated one, but it was considered possible to construct an adequate vehicle for this amount. The URF was ordered in early 1974 to be delivered in 1977 by the Swedish shipyard Kockums in cooperation with the French company COMEX.

#### General Description

The URF has a length of 13.5 m, beam 4.3 m, and height 3.9 m. Displacement is 49 tons, maximal diving depth 460 m, and maximal rescue depth 300 m. Speed submerged is 3 knots. The total endurance is 40 hr, with an estimated mission profile of 10 hr each for towing, rescue operation, and towing with a 10-hr safety margin. The vehicle is divided into four compartments (Fig. IVD-1):

- Operator's Compartment (OC), internal pressure	1 ATA
- Rescue Compartment (RC), internal pressure	1 - 10 ATA
- Auxiliaries' Compartment (AC), internal pressure	1 ATA
- Divers' Compartment (DC), internal pressure	1 - 31 ATA

The normal crew is two operators in OC, one engineer in AC, and two divers in DC. The RC can take a submarine crew of 25 men.

The base of the URF will be the Naval Diving Center, 30 km south of Stockholm, where it will be stored on a trailer in the same building as the stationary pressure chamber complex. A PTC is available for transference of personnel from the URF to the stationary chambers.

#### Operation

On the "SUBSINK" alarm, the URF will be taken on its trailer to the nearest harbor with either adequate lifting capacity or convenient slipway for launching. Simultaneously, a surface vessel for towing the URF will proceed to the same harbor. In the meantime, the site will be established by other naval ships. After having been towed to the place, the URF will proceed on its own to the sunk submarine. Within one nautical mile the URF will be guided by a pinger signal and a passive sonar, while the active sonar will be used for

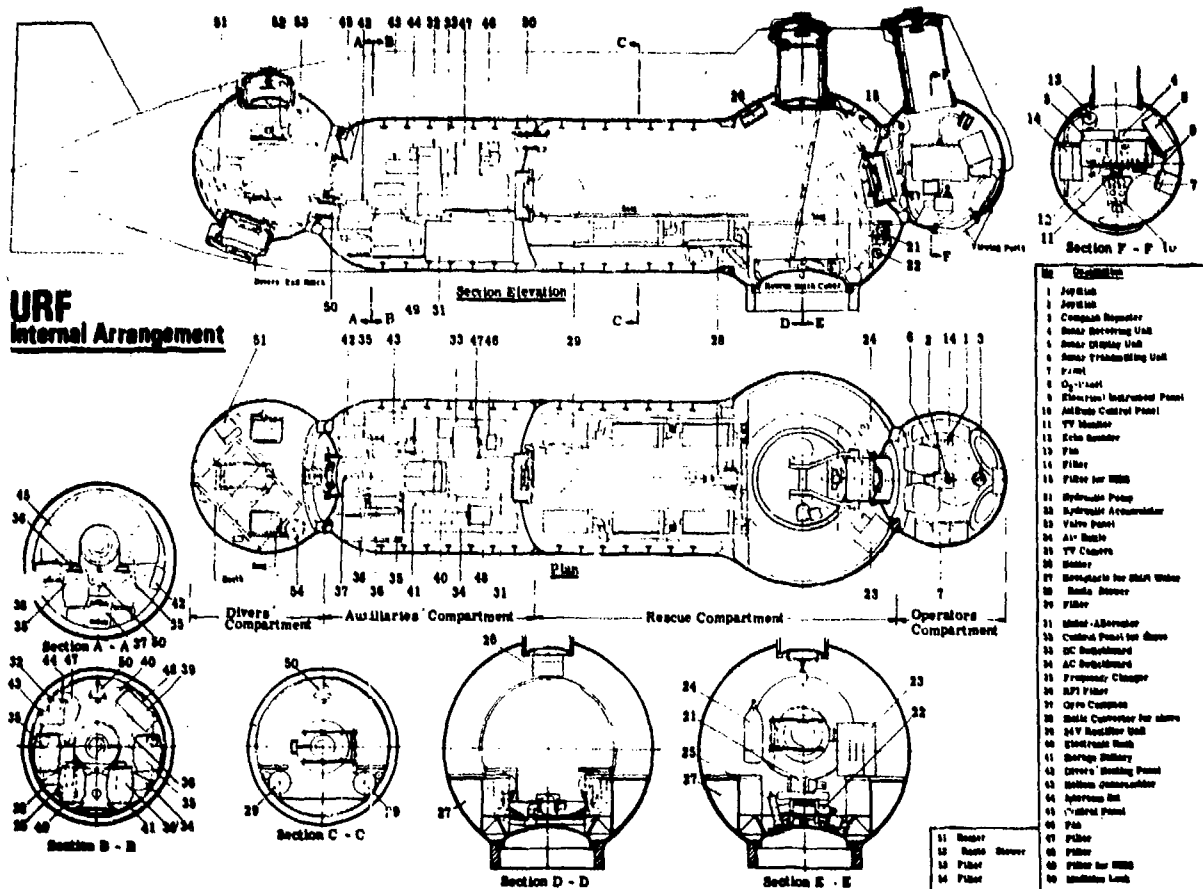

Fig. IVD-1. Internal arrangement of the URF.

the last part of the approach, until visual contact is established at a distance of 2-10 m. During a normal rescue operation, a wire will be connected to the rescue hatch cover of the submarine by means of the URF manipulator and mating completed by winching down the URF. The hatches will then be opened and the crew will transfer to the URF (Fig. IVD-2).

Life support system--The system is manually controlled but there is a duplicate system in that the functions are controlled both from the OC and from the AC. Oxygen is stored outside the pressure hull in 200-atm cylinders and supplied separately to the different compartments. For compartments with atmospheric pressure  $PO_2$  is kept at  $0.2 \pm 0.03$  ATA. When pressure is increased in the DC or RC,  $PO_2$  may be increased up to a maximum of 1.2 ATA for restricted periods. Each compartment has an oxygen sensor which can be read by the personnel in each compartment and centrally from both OC and AC.

Carbon dioxide is removed by separate sodalime scrubbers in each compartment. The  $CO_2$  level is kept at 0.5 - 1% (or the equivalent at increased pressure). The level can be checked intermittently by chemical absorbent tubes.

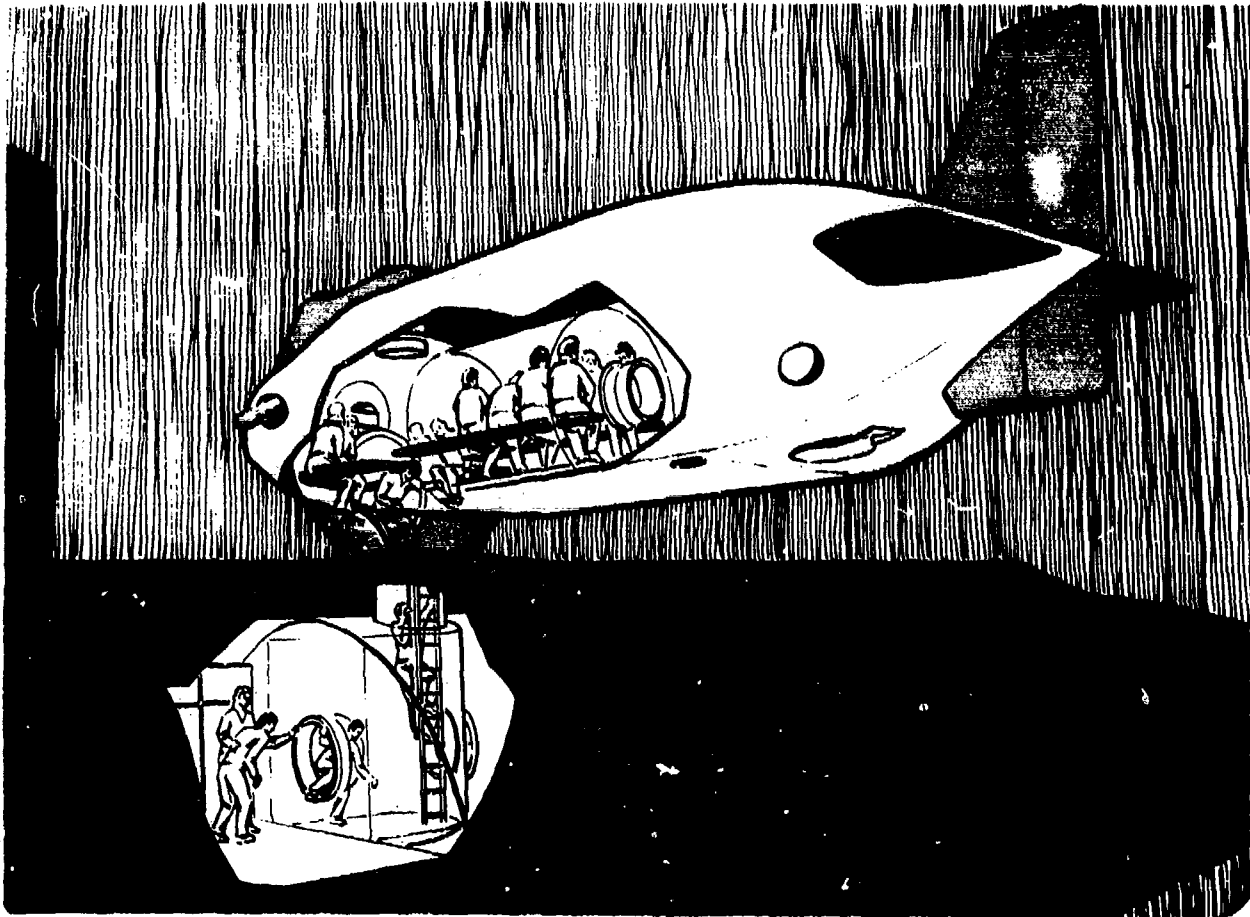

Fig. IVD-2. Crew transfer from the URF.

Temperature is controlled by an electrical heating system which will ensure a minimum level of  $15^{\circ}\text{C}$  when the water temperature is  $0^{\circ}\text{C}$ . The DC, however, is equipped with extra insulation and heating so that the level can be kept at  $30^{\circ}\text{C}$  when helium is used. Except for the RC, humidity is controlled by silicagel filters to a level of about 70% relative.

The endurance of the life support system is 50-70 hr, except for the RC which has a capacity of 20-25 hr. The other compartments are also equipped with an emergency breathing system or with breathing apparatus which have an extra capacity of 12 hr.

Rescue operation--Rescue will be performed according to three different procedures according to the condition of the disabled submarine.

(1). Under favorable conditions docking will be made as described above without exposing any personnel to increased pressure. The submarine crew will be transferred to the rescue compartment at normal pressure and can be taken to surface within a short period.

(2). The docking procedure may for some reason require assistance by divers who will be locked out from the DC. In this case the DC will be

pressurized with air to a maximum of 40-60 m and with helium for further depths down to 300 m. The compression time should not exceed 30 min. One diver at a time will enter the water with umbilical gas supply and a breathing apparatus as a reserve. Cold protection will be accomplished by an air-insulated suit and electrical gas heater. Two different breathing gases will be available for use, depending on depth--air to 40-60 m and heliox or trimix with 5% oxygen for greater depth. The gas supply will permit a total working period of at least 2 hr in water, which would imply alternating periods of about 30 min for each diver. For depths exceeding 150-200 m, decompression periods of several days will require that divers be transferred by the PTC from the URF to the stationary chamber at MDC.

(3). Situations may occur when it is impossible to perform a docking procedure due to unfortunate position of the submarine or damage to the docking area. In these cases the URF will hover closely above the hatch of the disabled vehicle, with a free entrance to the RC which compressed to the surrounding pressure. The personnel compartment of the disabled vehicle will then be compressed with air to the external pressure, or flooded with water, after which the rescuees can be transferred one at a time, assisted by a diver, from the disabled vessel into the URF. This procedure is necessarily a complicated one, but it should be possible to perform at depths down to 90 m. The rescue procedure would probably take 1-2 hr, which would necessitate a prolonged decompression period in the RC or, after transportation by the PTC, in a stationary chamber.

This method could also be utilized in other cases when docking is not possible. Personnel trapped in another submersible, in a habitat, or in a sunken vessel, at normal or increased pressure, could be rescued by this procedure. Unfortunately, the method would in most cases be limited to about 100 m since the disabled vehicle would only have access to air as a breathing medium.

#### E. ONE-ATMOSPHERE DIVING SUIT: CDR. J. VOROSMARTI

A workable 1-atm diving suit for deep diving has been sought for many years as an alternative to the standard diving dress which exposes the diver to ambient pressure. The reasons for this interest are obvious. A 1-atm suit would do away with a great many of the problems encountered in standard diving; lengthy decompression in the water, decompression sickness, cerebral air embolism, use of mixed gases, poor communications, hydrostatic pressure differentials on the body, etc.

Theoretically this type of apparatus should provide 1-atm conditions to great depths while preserving the capability of free motion for the diver to do work with stability in tidal flows and currents. Historically there have been no problems in providing the first requirement but the second has been very difficult to achieve. The early suits were very cumbersome and did not provide the mobility required. This was generally because of the inability to design mechanical joints which did not seize under increased pressure. The most successful model, built by J. Peress, used fluid-lubricated joints and provided much better flexibility at depth.

The particular suit discussed here is the JIM suit (named for Peress) built by DHB Construction Ltd, Farnborough, Hants, England. It is a modification of the Peress suit-joint system allowing for great flexibility with no joint seizure at depth (Fig. IVE-1).

The suit is classified by Lloyd's as a submersible. Its test depth is 2000 ft with certification to 1300 ft with occasional excursions to 1500 ft ("occasional excursions" is undefined). The dry weight is 910 lb and it is ballasted with 150 lb of lead. The buoyancy can be adjusted within the range of 15-50 lb with this lead. There is a large rear weight which can be dropped by the operator which makes the suit positively buoyant. It is stated that in this buoyant mode the suit will rise to the surface at the rate of 100 ft/min in the upright position.

The basic life support system is shown schematically in Fig. IVE-2. The diver breathes the atmosphere in the suit to which oxygen is added and from which CO<sub>2</sub> is absorbed. The system shown, with the exception of the changeover valve, breathing tubes, and oronasal mask is duplicated in the suit and by merely turning a lever on the changeover valve the diver can switch from one system to the other. The oxygen cylinders each contain 500 liters at 200 atm. The flow is through appropriate valves in the hull of the suit to a pressure reducer which decreases the pressure to 100 psi. Pressure gauges above and below this reducer are provided. The oxygen flow is metered by the flow controller which consists of a tilt valve operated by a diaphragm with suit pressure on one side and a reference chamber containing 1 ATA on the other side. This will control the pressure in the suit at 1 ATA  $\pm$  0.09 ATA. The flow restrictor in the main line will hold the oxygen flow to 3 liters/min in the event the flow controller fails open, while the flow restrictor in the bypass line will maintain 0.25 liters/min flow if the controller



Fig. IVE-1.  
Overall view of JIM suit.

fails closed. The oxygen is injected into the inhalation hose leading to the oronasal mask. Inhalation is through a canister containing 1 lb of  $\text{CO}_2$  absorbent. An oxygen sensor provides a readout of the oxygen level in the suit (it has been recommended that the sampling point for this be in the inhalation tube downstream of the oxygen injection point).

The duration of the life support system can be worked out very simply by assuming any oxygen consumption. The life of the  $\text{CO}_2$ -absorbent system is more difficult to calculate because of variables of temperature, humidity, and acceptable  $\text{CO}_2$  level, but the range is calculated to be between 500 and 1000 liters of  $\text{CO}_2$ .

This breathing system has been evaluated for breathing resistance. Using the steady-flow method of Cooper, the resistance of the total system was less than the recommended limit at flows up to 60 l/min and below the maximum limit at flows up to 90 l/min. In subjective terms the resistance is noticeable by



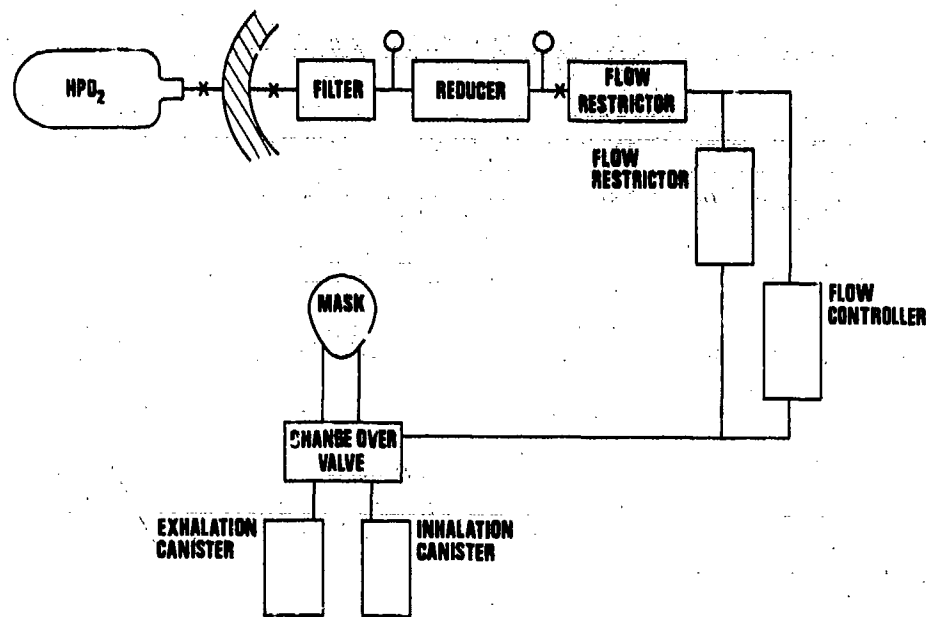

Fig. IVE-2. Schematic diagram of life support system (see text).

the divers when exercising but does not cause any respiratory embarrassment. This problem could be solved if a mechanical recirculation unit could be designed for the suit. The operator would then not have the breathing resistance of the mask, tubing, and absorbent canisters to contend with (Fig. IVD-3 and IVD-4). The oronasal mask has caused some problems due to leakage around it; also, it interferes with the visual field of the operator by preventing him from getting his face close to the view ports. Other concerns are the lack of humidity and thermal control and these need to be solved if any long-term dives are to be undertaken.



Fig. IVE-3. View of some components of life support system (A. exhalation canisters; B. inhalation canister; C. flow controller; D. change-over valve).



Fig. IVE-4. View of operator in suit wearing mask and showing pressure gauges.

F. WHY MANNED VEHICLES: H. TALKINGTON <sup>1/</sup>

Although manned systems are useful, exciting, and, many times, necessary, the majority of undersea tasks facing man can be accomplished more safely, economically, and as thoroughly with unmanned systems. Guidelines for making the decision to use a manned or unmanned system for the execution of a specific undersea task are proposed and explained. Three examples are presented: exploration (use of a manned system), search and recovery (use of manned and unmanned systems), and work (use of an unmanned system).

The first example involves the TRIESTE (Fig. IVF-1), which was the first successful, manned deep-diving, free-swimming submersible. It enabled man to dive into the depths of the sea in the relative safety and comfort of a 1-atm pressure hull. Because the hull was heavy steel, it required a large gasoline-filled float to give the submersible an overall neutral buoyancy. For looking at the undersea world outside the TRIESTE there was one 10-cm diameter viewport in the steel pressure hull. This is the vehicle that carried man into the deepest part of the world's oceans--to the bottom of the Marianas Trench.

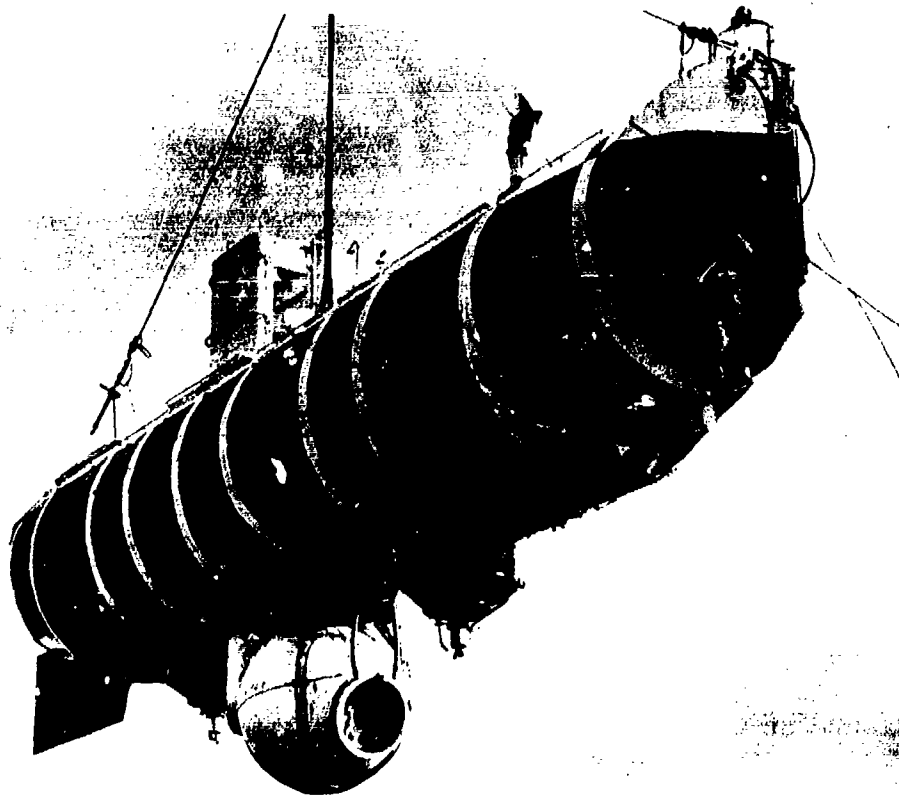

Fig. IVF-1. TRIESTE

<sup>1/</sup> An expanded version of this paper first appeared in a report of the U. S. Naval Undersea Center entitled, "Why Man."

For the second example we must return to early 1966 and to the Mediterranean Sea near the Spanish village of Palomares. Two aircraft of the U.S. Strategic Air Command had collided in midair and scattered wreckage and four H-bombs around Palomares, one of which was lost in the sea. For almost 3 months search and recovery efforts were diligently pursued. The efforts embraced every way man can extend himself under the sea; there were divers as well as manned and unmanned systems. While divers worked the relatively shallow water, manned Perry submarines and also ALVIN (Fig. IVF-2), and ALUMINAUT, searched the deeper, more rugged areas. The MIZAR (Fig. IVF-3) provided an instrumented, unmanned sled which enabled the searchers to

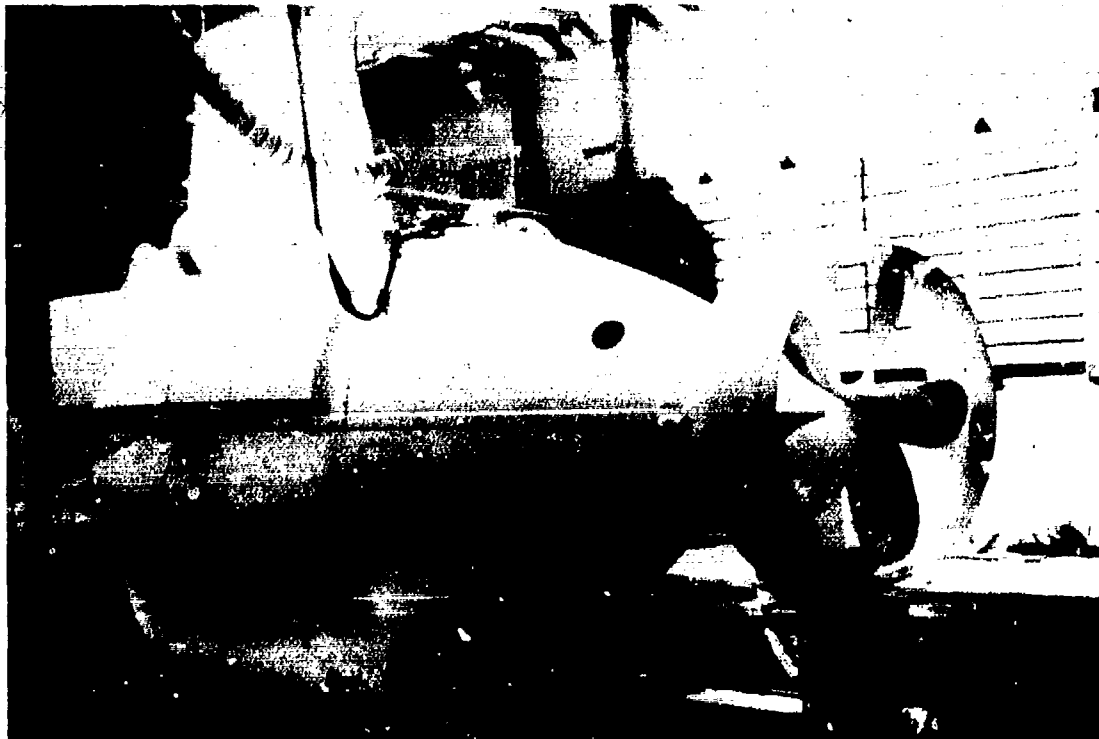

Fig. IVF-2. ALVIN

examine a large area (about 25 square miles) to depths, if necessary, of 20,000 ft. The MIZAR has a center well through which the sled is lowered and then towed at the selected depth.

ALVIN twice found the lost bomb; the unmanned CURV I was used to recover it. CURV I (Fig. IVF-4) had been developed for recovering test ordinance at the Naval Undersea Center's Long Beach and San Clemente Island test ranges to depths of 2000 ft. To meet the need at Palomares CURV I was modified so it had the capability of doing work at greater depths.

The bomb was tenuously resting on a craggy slope at the brink of an undersea canyon, and the parachute that was still attached to it was drifting back and forth in the current. There were two dangers here for those attempting a recovery: the first was getting entangled in the parachute shrouds

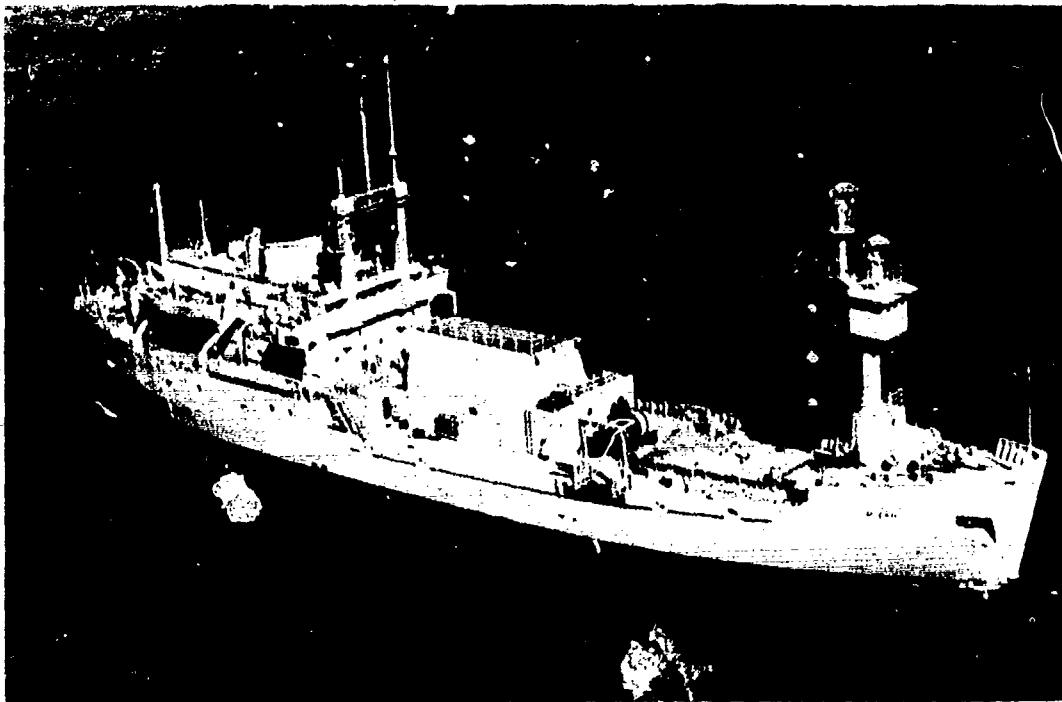

Fig. IVF-3. MIZAR

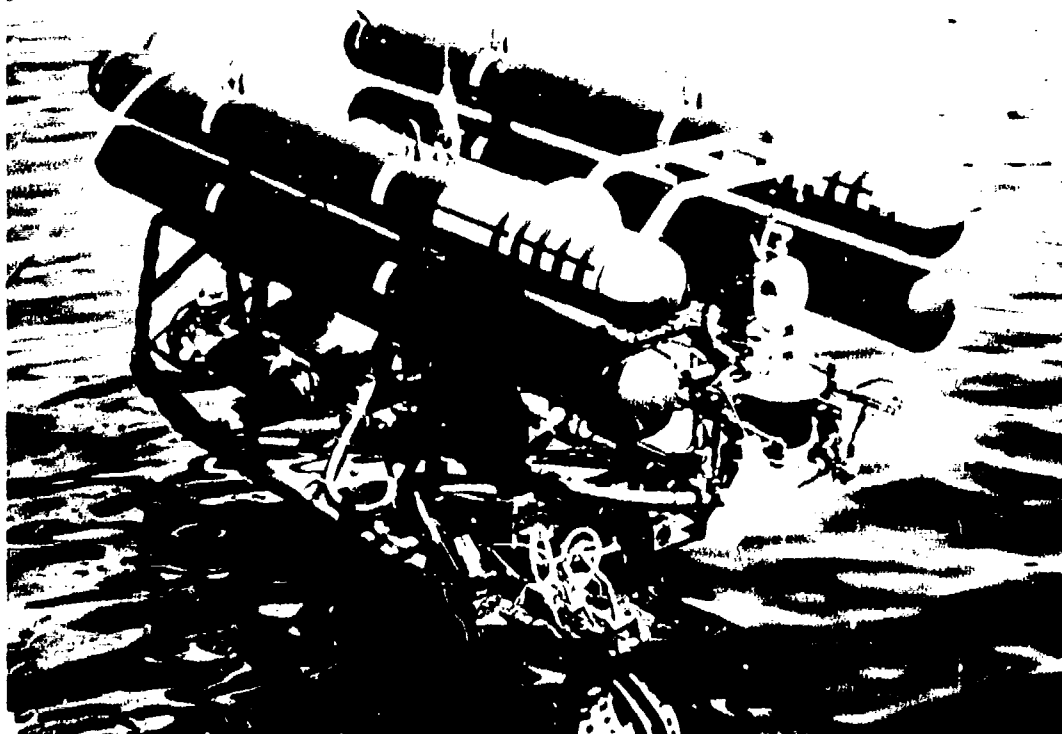

Fig. IVF-4. CURV I

and the second was dislodging the bomb and possibly losing it deeper in the sea. When it was first discovered, ALVIN tried to attach a marking pinger, but it became entangled and there were some nervous moments before it worked itself loose. After that ALVIN preferred to stand back, and thus the unmanned CURV I made the necessary attachments and raised the lost bomb to the surface (Fig. IVF-5) from a depth of 2850 ft. This was an intricate, tense, and vital example of different types of systems working together to conduct a successful operation.

## ¡HE AQUÍ LA BOMBA!



La bomba perdida fue mostrada a la Prensa mundial a bordo del buque "Petrel". Foto Victor Manuel

Fig. IVF-5. Recovered H-Bomb

The third example consisted of a major overhaul of the Azores Fixed Acoustic Range (AFAR) which was well handled by an unmanned system. This was CURV III (Fig. IVF-6), the latest in the series of unmanned vehicles, which has all the necessary equipment for searching for, locating, and documenting the recovery of a lost item or the completion of a particular support task at depths to 7000 ft. This equipment comprises both active and passive sonar, two closed-circuit TV systems, a 35-mm documentary camera and strobe, and an underwater lighting system. The standard work tool is a hydraulically operated claw; special work tools and equipment, however, can be readily attached to the vehicle. Before CURV III performed the tasks it was assigned to do at AFAR, engineers reviewed the requirements and supervised the necessary modifications. The tasks accomplished by CURV III at AFAR included rigging one of the 125 ft acoustic towers so that it could be lifted from the sea floor, cutting various underwater electric cables that were from 1.5 in to 3.5 in in diameter, retrieving underwater electric cables from the ocean floor (Fig. IVF-7), sonar mapping of the acoustic tower sites, and inspecting the underwater range once all the other tasks had been successfully completed.

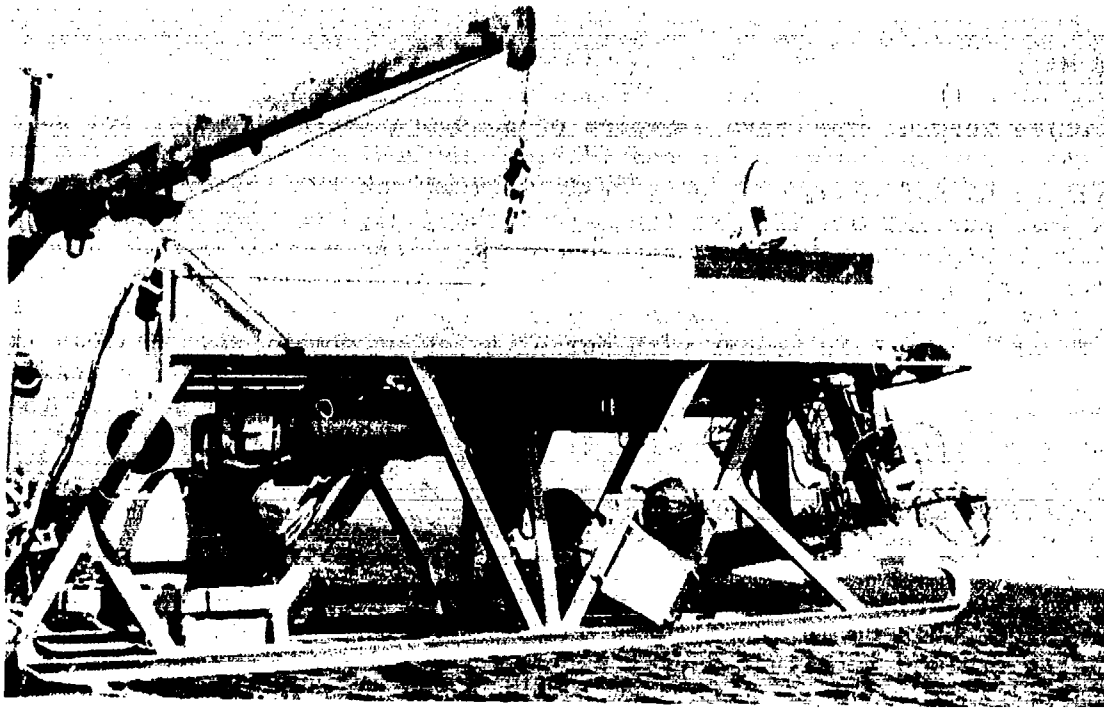

Fig. IVF-6. CURV III



Fig. IVF-7. An AFAR task.

## Why Man?

While keeping the above examples of undersea tasks in mind, let us return to the question why man? In considering our goal of fully using the marine environment and resources, once again we must ask the following questions: How does putting man in a system affect the goal; how does he impact the relationship between desire and economics? These questions should be answered before any system is made the focus of time, effort, and money.

First, we must be honest with ourselves about ourselves. Man has the desire to see, to know, to be there. He has an ego: he wishes to leave his personal mark, he wants others to acknowledge that achievement, and then he pushes on. That man is a searching, conquering, proud being must be taken into account because this conviction affects the thinking of everyone who establishes goals for an undersea project, especially those who always insist that man must be present on site.

Beyond the desire for personal accomplishment there are other reasons man should or could be included in an undersea work or exploration system. When a man's trained intellect and senses are part of a system, he is able to repair, reset, adjust, and adapt, in short, respond to the unusual situation. The free-swimming diver comes closest to exercising directly his senses in the ocean (primarily seeing, touching, and hearing). The man in the manned submersible, however, is sensing his environment remotely, except for one sense--that of sight. In the unmanned system all sense data is remotely perceived. Thus, the primary reason for including man in a system is to make use of his active, interpretive ability to see.

## The Cost of Manned Systems

There should be irrefutable reasons for putting man into the sea, because the cost is high for risking a human life in a hostile environment. The safety factor makes it necessary that the system sustain and support human life. Therefore funds must be allocated to support man and not be directed toward accomplishing the goal. An adequate life support system consists of more than the equipment specified strictly for life support. Because manned systems are not currently powered from the surface, they require a self-contained power supply comprising special high energy batteries and charging systems. The power supply increases the weight and volume of the system, and it generates power for only a relatively short time thus severely limiting mission endurance; both of these facts represent a costly impact on system effectiveness. When man is in the system he must be protected from the hostile environment by a pressure hull. Since the pressure hull is usually made of steel, it becomes the largest, heaviest, and most costly part of a manned submersible. Once the manned submersible is constructed it must undergo man-rating certification, which procedure is not only costly in itself, but imposes necessary and costly design constraints. Along with the safety factor is the anxiety factor: when ALVIN was entangled in the bomb's parachute shrouds there was a great deal of concern for the safety of those on board. A man in a system also complicates the already difficult problem of handling because manned systems, besides being larger and heavier, require

a special fail-safe handling capability and any accidental rough handling could result in injury or death. This handling capability also adds expense to the system.

Experience with the DEEPSTAR-4000 illustrates what has been said. In order to meet some specific test objectives, DEEPSTAR had a full complement of scientific instrumentation (Fig. IVF-8), which included sound velocimeters, salinometers, water sampling devices, and a coring device, mounted on it. During many of the test dives the scientist inside the submersible was so busy that he never looked out the viewport. The question must be asked--did the "observer" need to be there on site? He used none of his senses to learn about the environment. Could these particular tasks have been accomplished just as well (and more safely and economically) with a remote-controlled system?

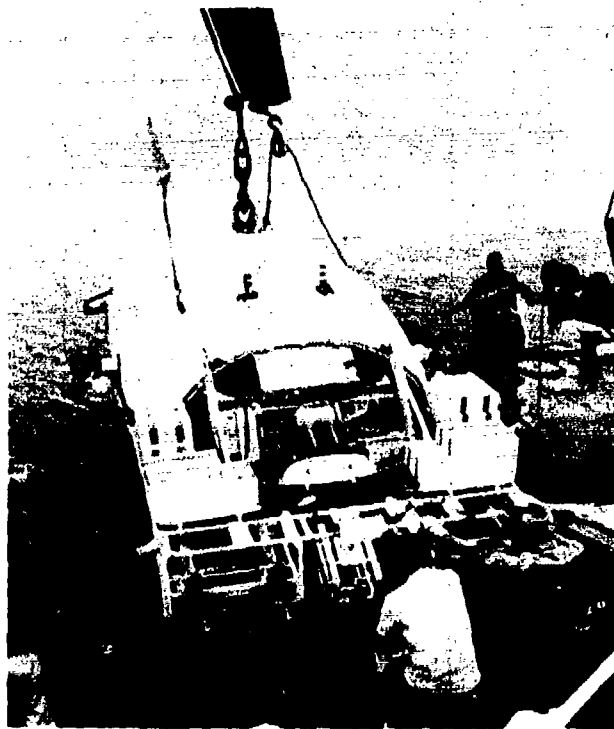

Fig. IVF-8. Instrumented DEEPSTAR

#### Unmanned Systems and Data Collection

Another question is necessary: is man required on site in order to get the information we want and need regarding the ocean environment: Table IVF-1 is a list of ocean exploration and survey parameters compiled by the National Academy of Engineering Marine Board Panel on Platforms for Ocean Exploration and Surveying at Airlie House, Virginia in February of 1972. The list shows which parameters are pertinent at each of five separate levels: the air-sea interface (+10m to -10m), the upper water column (-10m to -500 m), the lower water column (-500m to bottom), ocean floor, and subbottom. Not only are



Table IVF-1. Ocean exploration and survey parameters

Parameter	Air-Sea Interface (10 to -10m)	Upper Water Column (-10m to -500m)	Lower Water Column (-500m and deeper)	Bottom	Subbottom
1 Ice	X				
2 Sea-swell-surf	X				
3 Surface Meteorology	X				
4 Surge	X				
5 Tides	X				
6 Currents	X	X	X		
7 Hydrodynamic Forces	X	X	X		
8 Noise	X	X	X		
9 Salinity	X	X	X		
10 Temperature	X	X	X		
11 Turbidity	X	X	X		
12 Biomass	X	X	X	X	
13 Nutrients	X	X	X	X	
14 Oxygen	X	X	X	X	
15 Pollutants	X	X	X	X	
16 Electrical		X	X	X	
17 Bathymetry				X	
18 Geomorphology				X	
19 Rheology				X	
20 Engineering Properties				X	X
21 Geochemistry				X	X
22 Geology				X	X
23 Geothermal				X	X
24 Physical Properties				X	X
25 Radiometric				X	X
26 Gravity					X
27 Magnetics					X
28 Seismic					X

Table IVF-1. Ocean exploration and survey parameters

there many parameters to be measured, but they must be measured in many areas of the world before the oceans, which cover three-quarters of the earth, can be fully utilized. Many measurements in many areas is the desired goal, but once again economics affects accomplishment. It was the conclusion of the Airlie House panel that buoy systems and unmanned systems should be used whenever possible. This would avoid the expense of using a manned system such as DEEPSTAR when the only responsibility of those on board is to ferry the instrumentation to the appropriate level for gathering data.

Buoy and unmanned systems are available now for the work, exploration, and data gathering that will render the sea most useful for man. SONODIVER (Fig. IVF-9) is an unmanned, untethered deep diving vehicle designed to operate to depths of 20,000 ft. It provides a quiet platform for gathering acoustic and other environmental data at predetermined depths. In operation, SONODIVER, once launched, descends to the selected depth where it releases its descent weight, hovers, takes data, releases the ascent weight, and returns to the surface. SONODIVER is capable of acquiring much of the same data that manned systems have taken in the past. Another example of present unmanned systems is SEAPROBE (Fig. IVF-10), a surface ship which has a drill-string attached, at the end of which is an instrument pod with a large manipulating capability. This new development has shown that man can work at extreme ocean depths and that he can remote his senses and his manipulative abilities from the safety of the surface to the location requiring his attention. SEAPROBE has recently successfully completed a task which required its capabilities for the handling of array systems in the Bahamas.

Unmanned systems come in a variety of shapes and sizes (Fig. IVF-11). SNOOPY is a 50-lb unmanned vehicle with a television camera and a small claw. It is essentially a remote-controlled, swimming television system which can perform underwater search, inspection, observation, and classification missions. SCAT is a 400-lb remote-controlled, swimming television system that makes use of a head-coupled television which gives the operator a much more vivid "sense of presence" at the work site than remote monitors usually do. Under the Deep Ocean Technology (DOT) Program, the Remote Unmanned Work System (RUWS) is being constructed for engineering tasks in the deep ocean. RUWS will have two manipulators, one a heavy grabber and the other a highly articulated manipulator; television cameras; and other instrumentation required for the successful completion of its mission. Its 20,000 ft depth capability will give the RUWS access to more than 98% of the ocean floor.

### Conclusions

First, it is recognized that, to meet the challenge of making a thorough and effective use of the marine environment and its resources, a full complement of manned and unmanned systems will be required. Second, it is imperative that unmanned systems be used as much as possible. Unmanned systems are best suited to the greatest number of undersea work and exploration tasks for at least six reasons: relative economy of development in time and equipment costs when compared with manned systems, unlimited operational endurance on site by virtue of the cable link to the surface, surface control and coordination of project efforts (thus avoiding clash of operational philosophies) ability to perform in hazardous areas without endangering personnel, ability

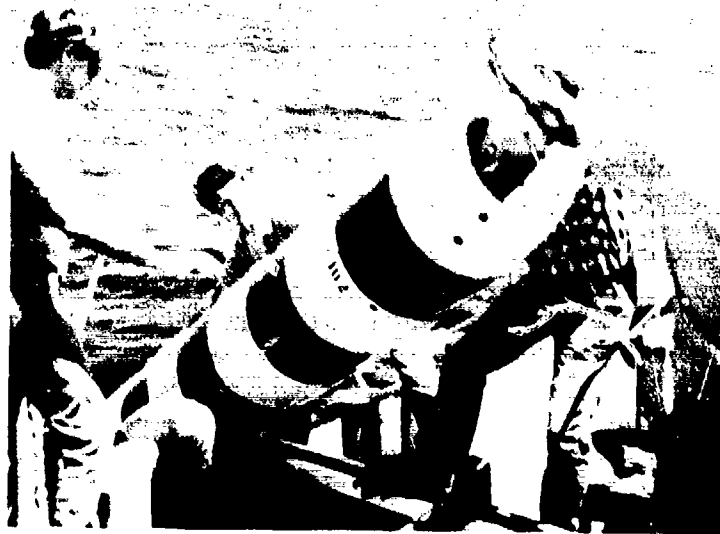

Fig. IVF-9. SONODIVER

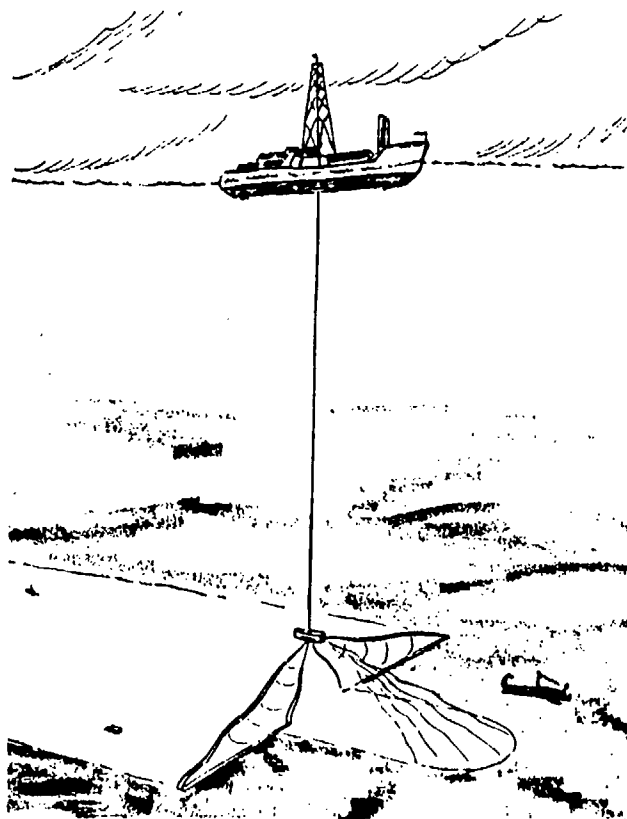

Fig. IVF-10. SEAPROBE

to change or modify all system components to meet individual tasks or range needs without affecting system safety or certification status, and ease of changing crews without any disruption to the mission (men simply leave their places at the control consoles and immediately their replacements are there to take over). In addition, because these systems are usually smaller and lighter as well as unmanned, the handling problem is significantly reduced.

Third, man should be included in a system only if he is absolutely necessary for the success of the mission because his presence in a system drastically increases the cost of the system in more safety considerations, system complexity, handling problems, and time. Also, if man's presence is necessary for a successful mission, it is most likely because the mission requires real-time, high-resolution sight. A corollary to this observation is that, if a man is needed for seeing, then provide him with a system which offers maximum visibility.

While the Navy's TURTLE and SEA CLIFF (Fig. IVF-12) are versatile research submersibles capable of performing search, recovery, photographic, and scientific tasks to depths of 6500 ft, they have only relatively small viewports. We now have submersibles (Fig. IVF-13), which, besides being fully instrumented, provide maximum or panoramic visibility. Among this group are NEMO, SEA-LINK PC-8, MAKAKAI, and DEEPVIEW. NEMO, the first fully operating and certified submersible using an acrylic hull, is a self-contained system with a one-atmosphere environment. It carries its crew of two on missions to depths of 600 ft, and the acrylic sphere affords the crew all-round visibility. SEA-LINK makes use of an acrylic sphere like NEMO's which allows for the required visibility, but it also has a welded aluminum hull for diver transport and lock-out capability. Designed to operate at more than 3000 ft depths, the SEA-LINK will also provide a team of three divers capable of working at 1600 ft depths. The PC-8 of Perry Oceanographics, Inc., has an acrylic nose which permits good forward visibility. Equipped with navigation and control instrumentation, a communication system, and a manipulator arm, the PC-8 can operate to depths of 750 ft for 2 hr of continuous running at a maximum speed of 4 knots or for 8 to 10 hr at 1 knot. MAKAKAI, "eye of the sea," lives up to its name. Also making use of a transparent acrylic sphere as its pressure hull, the MAKAKAI is a two-man free swimming submersible with an operating depth of 600 ft. Its two pi-pitch cycloidal thrusters give the submersible a cruising speed of 0.5 to 0.75 knots with a maximum speed of 3 knots. At cruising speed MAKAKAI can operate for 6 hr. Finally, DEEPVIEW, a two-man submersible with a transparent bow, is the first submersible to make use of massive glass as a significant portion of the pressure hull. Its nose is a large glass hemisphere 1.5 in thick. While providing the desired visibility, DEEPVIEW operates to depths of 600 ft at speeds from 1 to 3 knots for 6 hr.

#### Summary

In summary this paper has acknowledged the overall goal of developing, promoting, and supporting a national, operational capability for man to work under the sea in order to achieve a better understanding, assessment, and use of the marine environment and its resources. At the same time, it noted in Table IVF-1 some of the particular data requirements that have to be met if

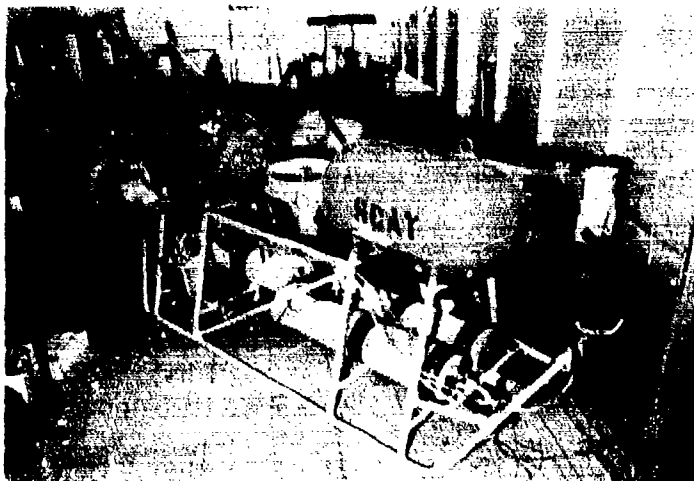

SCAT



SNOOPY

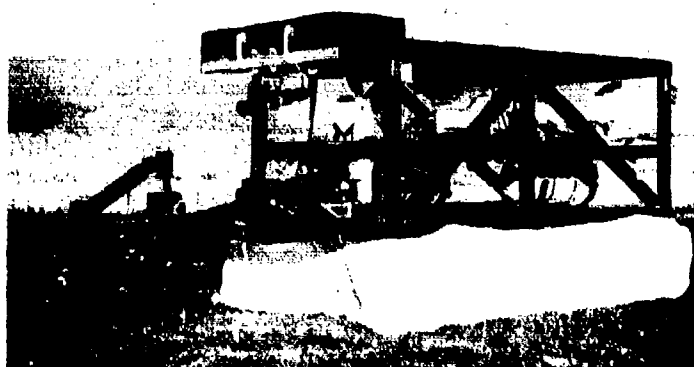

RUWS

Fig. IVF-11. Unmanned vehicles

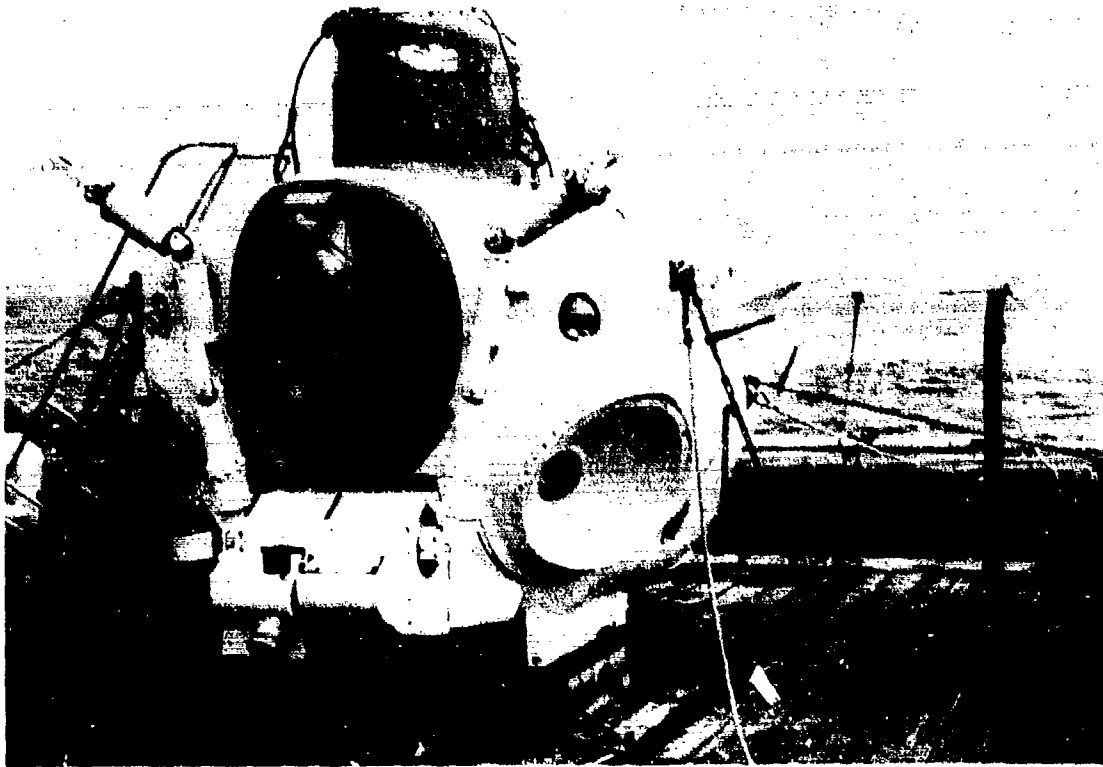
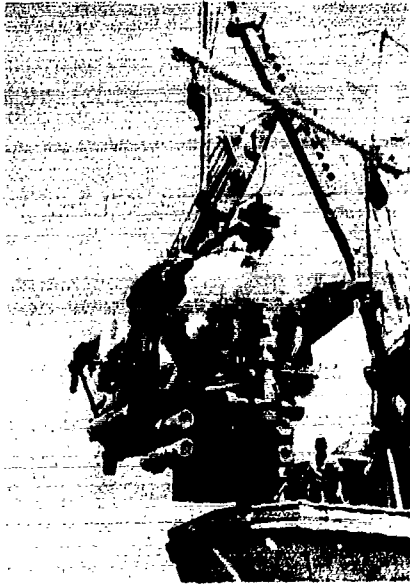
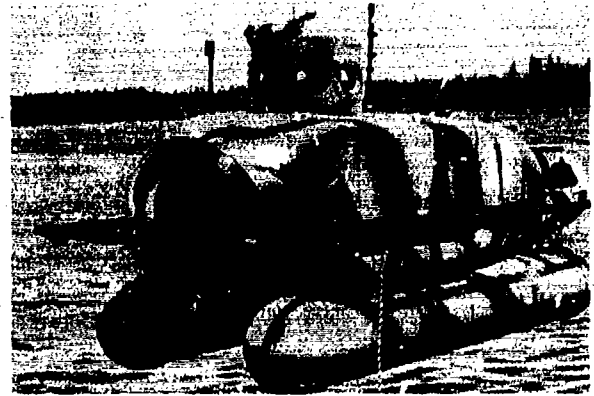

Fig. IVF-12. SEA CLIFF

the overall goal is going to be attained. It gave examples of tasks various systems will be confronted with as the marine environment is made more and more available to man. Then the question, why man?, was asked. To put man under the sea entails high costs in money, time, and complexity. Thus, the following conclusions were reached: Both manned and unmanned systems are necessary to attain the goal. However, it is obligatory that unmanned systems be considered first and used whenever and wherever possible. Man should be considered for systems only if it is essential to the mission's success. And, since what makes man essential in a system is his ability to provide active, real-time, high resolution sight, then that system should enable him to exercise this ability to the greatest degree.



SEA-LINK



PC-8

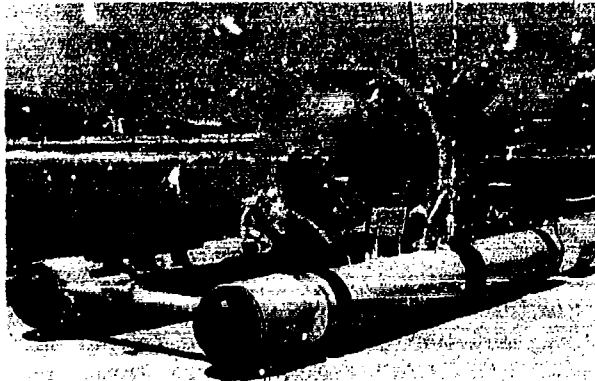

DEEVIEW

MAKAKAI

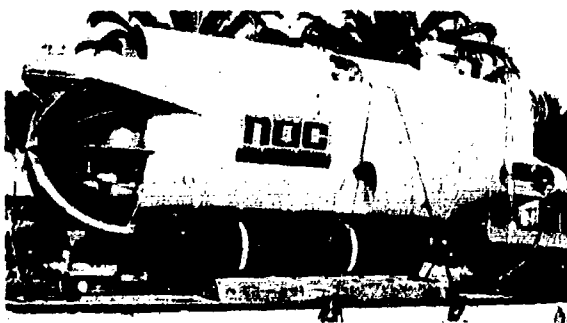

NEMO



Fig. IVF-13. Panoramic visibility submersibles

## SUMMARY OF DISCUSSION

Thermal protection of the lock-out divers was discussed. Several dives have been aborted when the divers became simply too cold to proceed any further with safety. A concerted effort is needed to determine respiratory and skin energy requirements to maintain thermal equilibrium at depths in excess of 150 ft. Obviously, this problem is greater in diversubs than in diving bells because of the limited power supply.

Under Harbor Branch Foundation's present operating rules, no one rides in the aftercompartment of that submarine who is not fully trained and qualified in mixed-gas diving lock-out procedures. He must have full equipment to take care of the situation. They have added saturation capabilities, so that under any circumstance a diver can blow down and take a look at things. If he breathes a high O<sub>2</sub> mix, he can correct the problem and decompress on a standard schedule but, if not, he might have to wait down there for a long time. If they get him to the surface, however, they can lock him on to a deck decompression chamber and go standard saturation decompression.

They will still have to deal with the thermal problem. The non compressible wet suit looks promising. Two companies that make the material are Maury & Mancini and 3-M. The Maury & Mancini is much more pliable than the 3-M. The 3-M suit is also irritating. A new one is being tested in May. One nice thing about it is that it is very heavy so that lock-out work does not require weight belts. This helps in getting in and out of hatches.

It was asked how many rescuees the DSRV could carry during one rescue dive. The original number was 24, based on the amount of ballast carried and then dropped as each rescuee came on board. This total weight was based on an average individual weight of 170 lbs, which, apparently, is too low. Additionally, there is emergency breathing equipment on board for 12 rescuees and 1 crewman in each of the two spheres which house the rescuees. This total number has been modified to 18 recently because of other weight constraints added to the boat. The final number will depend on the weight of each man and other equipment modifications which are taking place during the DSRV's operational evaluation. Another point was made that if a Polaris boat were distressed, it would be necessary to know if it were the beginning or the end of the patrol cycle. The average weight gain by the end of a patrol could be as much as 20 lb per man.

Experimental work is going on at Submarine Development Group One on the efficacy of the performance of mid- and aft-sphere crew members in the atmospheric mode which would be encountered if the disabled submarine were pressurized. Trained divers that have been exposed to elevated nitrogen partial pressures of 4.8 ATA have shown definite decrease in their cognitive functioning. There were two cases of central nervous system decompression sickness from this limited depth using standard decompression procedures. Subjects have also been monitored with an ultrasonic bubble detector. In all but one subject, gas bubbles in the pulmonary arteries were seen, beginning with the 20-ft stop. One of the subjects who developed CNS bends had the highest count rate, at



least according to our early analysis. These findings indicate that decompression in a DSRV, even from the limited depth that they have gone so far, and with a short bottom time of only 30 min, may prove to be a problem with operators as well as with the potentially saturated crew from the distressed submarine. This problem needs further investigation. The next step in this study is to take DSRV mid- and aft-sphere operators to high nitrogen partial pressures to see whether any significant differences occur as compared with the trained divers.

Several questions were asked regarding "JIM". The question was asked whether escape from the British 1-atm diving suit was possible. Escape is not possible but the suit has the ability to drop 150-lb lead ballast and would slowly rise to the surface in an emergency. A question also came up as to the ability of a diver in JIM to work or see much below his waist. Indications were that experience and proper training with this gear on an open-sea salvage operation is quite limited and it is probably too soon to know. In a cold-water, long-duration dive, thermal discomfort should be anticipated because no provision for heating the diver exists. Because it has a 1-atm air environment, depth should not degrade its capability. The length of the tether to JIM was also discussed, particularly the point of trying to put a man on the bottom in the right spot with that length of line. The manufacturers compared JIM's effectiveness in a current situation with a standard hard hat rig and JIM appeared to perform better.

The Cable Operated Rescue Device (CORD), which is similar to the CURV system, was discussed. CORD is lighter and smaller than CURV and perhaps can be operated from a hovering helicopter. A further description of this system is found in Dr. Youngblood's presentation.

## CONCLUSIONS AND RECOMMENDATIONS

1. Power and payload limitations mean that one of the most serious life support problems is to maintain an adequate temperature within the diving compartment. It appears impossible at this time to heat the entire aftercompartment.
2. Attention must also be directed to providing sufficient energy to the diver's suit and or his breathing apparatus.
3. Accelerated interest in deep commercial and scientific operations insures the development of larger diversubs with longer duration capabilities.
4. It is likely that a combination of diversub and the articulated armoured suit will be developed in the near future to overcome the physiological limits of deep diving ran.
5. Definite deterioration of cognitive function may take place if crew members of the DSRV breathe normoxic nitrogen oxygen at 5 ATA from their emergency breathing system.
6. A substantial decompression obligation may occur in the event that submarine rescuees have been exposed to positive pressure. Given the time line of the rescue operation, they must be assumed to be saturated with nitrogen for the purpose of decompression analysis.
7. Another important potential consequence of this prolonged stay at 5 ATA is pulmonary oxygen toxicity.
8. If the rescuees are saturated with nitrogen, a shift to oxyhelium breathing theoretically could change a conservative decompression schedule into a disaster.
9. The maximum number of rescuees that can be accommodated for decompression in the DDC and in the mother submarine must be determined.
10. What methods of decompression should be used under the various positive-pressure situations must be decided.
11. A full-load test of DSRV life support function should be undertaken at maximal pressure.
12. The Swedish Navy has decided to replace their submarine rescue bells with an underwater rescue vehicle (URF). Its main characteristic will be:
  - a. capability of rescuing the total crew of a submarine down to a depth of 300 meters under normal pressure,
  - b. facilities for lock-out of two divers at this depth,
  - c. capability of rescuing a submarine crew exposed to air pressure of 10 ATA.

13. A 1-atm diving suit called JIM with an established Lloyds diving certification to 1300 feet has been tested successfully in the open sea. Breathing resistance is noticeable but not embarrassing. Visual fields are hampered by the oranasal mask. Long-term dives will dictate improvements in humidity and thermal control.

14. Both manned and unmanned systems are necessary to attain underseas goals. However, it is obligatory that unmanned systems be considered first and used whenever and wherever possible.

## SESSION V: NON-U. S. SUBMERSIBLE PROGRAM SUMMARIES

### A. THE SUBMERSIBLE PROGRAM IN THE UNITED KINGDOM: H. PASS

In the mid-1960's Vickers saw the need to exploit naval underwater technology for commercially-oriented underwater work. Vickers Oceanics Limited was founded coinciding with the world energy crisis and the need to accelerate development of North Sea oil.

The first unit put in the field was the ex-stern-trawler VICKERS VENTURER. The submersible chosen, after detailed market surveillance, to complete the system was PISCES I, built by International Hydrodynamics of Vancouver. VENTURER, 640 tons, 120 ft long, and capable of carrying 30 crew and operations people, was fitted out with the Vickers-designed "A" frame submersible handling gear. PISCES I, 715 tons, is 16 ft long, 11 ft wide, and draws 7.5 ft; it has a depth capability of 1140 ft with 170 hr line-support

The next ship acquired was VICKERS VOYAGER, a former fish-factory ship. This ship was fitted out to handle two submersibles by day or night in the adverse sea conditions encountered in the North Sea. Fully equipped with electronic and mechanical workshops, VOYAGER can operate submersibles in sea states 5 to 6. VICKERS VIKING, the third ship in VOL's fleet, came into operation in September 1974. She, like VOYAGER, can handle two submersibles in North Sea conditions and, in addition, is fitted with a deck decompression chamber (DDC) to work with the new generation of diver lock-out submersibles. Two further PISCES submersibles, P II and P III, are now operated by Oceanics, with more coming into service next year along with two more support ships.

#### P-Class Submersibles

Basic construction consists of two steel spheres; a crew sphere forward incorporating three view ports, which give 180° field of view, and a machinery sphere aft. Two smaller spheres forward and each side of the crew sphere provide trim using an oil system. A similar oil system, using flexible bags situated around the main sphere, provides the ballast system including fine ballast for depth control. Additional air ballast tanks are situated under the skins at either side of the submersible. Battery banks between the two large spheres provide propulsion power via two 3-hp electric motors, in addition to power for the electronic and ancillary equipment.

To fulfill their tasks, the P-Class submersibles are fitted with all the necessary equipment for navigation/surveillance, underwater work, and crew safety. Equipment includes depth sounders, obstacle avoidance sonar and a sonar transponder for tracking and navigation guidance by the mother ship. Work carried out underwater is generally centered around the large "torpedo" grab and the general purpose manipulator. In addition to their normal functions, both the grab and manipulator can be readily adapted to carry a wide range of hydraulic tools including: drill, impact wrench, grinder, mud pump and cable cutter etc., all of which are interchangeable underwater.

An established feature of the Vickers Oceanics service is the ability to adapt tools to provide quick economical solutions to problems. Typical of these adaptations are Cox guns, rock drills, sediment samplers and corers, and cutting equipment. Safety equipment incorporated in the P Class includes CO<sub>2</sub> alarms and scrubbers, water ingress alarms, and life support equipment for 170 crew-hours. In extreme circumstances the manipulator, claw, motors, and a drop weight can be jettisoned.

### Cable Burial

As fish trawls go deeper, the submarine cable is increasingly liable to damage that is very costly to locate and repair causing considerable delays and inconvenience. Vickers Oceanics devised an effective cable and repeater burial system using a jet trencher controlled from within the submersible. Burial rates of up to 1200 m (3/4 mile) per day are achieved; this includes preweighting the cable to facilitate its burial and to ensure that it remains covered. New equipment under development will greatly increase this burial rate.

### Pipeline Survey

One survey for BP Limited entailed the provision of full video recordings covering both sides of the West Sole-Easington gas line in the North Sea, coupled with a comprehensive report and drawings referenced to the video tapes. At the same time, cathodic protection-level readings were taken. The P III submersible operating from VICKERS VOYAGER undertook the survey in only 17 days in August, 1972 without delays in spite of adverse weather and sea conditions up to sea state 6. The submersible is fitted with complete video recording and monitoring equipment and the video cameras are individually steerable to ensure full coverage.

### VOL L I

The VOL L I is a rugged and reliable diver lock-out submersible capable of carrying up to four personnel to a maximum depth of 366 m (1200 ft). Navigation and communications equipment carried by VOL L I includes depth sounders, obstacle avoidance sonar, and a sonar transponder for tracking and navigation guidance by the support ship, plus an underwater telephone system and an auto-pilot. To supplement work performed by the diver, the submersible's own manipulators can be used to work and operate hydraulic tools for cutting, burying, etc.

The VOL L I is of modular construction, which simplifies maintenance and enables modifications to be carried out readily. The batteries are contained in a twin-pod arrangement which forms the under-carriage skids, and quick-change battery trays enable a turn-round between operations to be achieved in 2 hours. A transparent dome at the front of the submersible provides an unrestricted view ahead and a conning tower permits all-round vision. All pertinent diver lock-out controls can be operated from either the lock-out compartment or the forward compartment and life support facilities are provided for up to four persons. Safety features include an independent system

capable of blowing the ballast tanks dry at a full diving depth and a droppable weight.

#### Submersibles Other Than VOL

Manned submersibles--At present there are no UK owned manned submersibles operating in or around the UK other than those owned and operated by Vickers Oceanics Limited. One or two other companies or organisations are starting submersible operations in UK waters and from UK bases, but the submersibles themselves are all of foreign origin.

Unmanned submersibles--There are--as far as is known to us--two UK owned submersibles at present operating. These are ANGUS and CONSUB.

ANGUS is a small experimental unmanned submersible built, owned, and operated by the Heriot-Watt University in Edingburgh, Scotland. It is fitted with both T.V. and still cameras and is controlled by an umbilical cable from the surface. It has two horizontal thrusters. The main significant feature of the ANGUS vehicle is its ability to navigate. The navigation system has worked reasonably well but the use of only two beacons can cause confusion as to which side of the baseline the vehicle is on and some difficulty has been experienced with spurious readings. At present, the possibility of building a Mark II system is being considered and, if this development does take place, the operating experience gained with the Mark I vehicle should help to produce a useful tool for possible assistance with rescues etc.

CONSUB is an unmanned vehicle built by the British Aircraft Corporation and owned by the Institute of Geological Sciences. It is primarily for geological research work and is still in the prototype development stage. Equipment includes two horizontal and two vertical thrusters, two T.V. and two still cameras, and a rock core sampler. Early trials have been encouraging and work is continuing but there is still a long way to go.

CUTLET is another unmanned vehicle under development. It is a recovery vehicle broadly based on CURV and is being developed by the UK Ministry of Defence at the Admiralty Underwater Weapons Establishment in Portland. Design information has not been made available publicly. It is known that trials of the partially completed system were carried out in Autumn 1974 and that work is continuing.

As well as is known by Vickers Oceanics Limited and by Vickers Shipbuilders there are no other UK submersible activities worthy of note taking place at the present time.

## B. THE SUBMERSIBLE PROGRAM IN CANADA: M. D. MAC DONALD

There are presently four companies in Canada manufacturing and/or operating submersibles. These are International Hydrodynamics (Hyco), Arctic Marine, Horton Maritime Explorations, and Access. Hyco has built seven submersibles and has five more under construction. Arctic Marine has one (SEA OTTER); Horton Maritime Explorations own AUGUSTE PICCARD, BEN FRANKLIN, and Access has an under-ice submersible in the planning stage. This report concentrates primarily on those submersibles built and/or operated by Hyco. Information was requested from all four companies and their responses are included.

### Hyco Submersibles

Submersibles built by Hyco vary from the early PISCES I through a series of PISCES, leading up to the present PISCES VIII being built for Vickers Oceanics of England. During this time the Submersible Diver Lock-out I (SDL-1) and the AQUARIUS have also been built. The most recent design, the TAURUS, is in the design-construction stage. This is a 50,000-lb displacement submersible designed for 1-atm transfers and possible diver lock-out missions. The design of these submersibles generally falls into two categories, lock-out and nonlock-out. The PISCES and AQUARIUS submersibles are nonlock-out submersibles, the SDL and the TAURUS are lock-out submersibles.

### Design

In the PISCES-class submersibles, the operating depth varies from 1400 ft for PISCES I, to 6600 ft for PISCES, IV, V, VI, and VII. Their construction and operations span a period of 10 years. The number of dives accumulated on PISCES-type submersibles is approximately 3200, in locations varying north and south from the Arctic to the Bahamas, and east and west, from the North Sea to the Pacific.

PISCES submersibles have the following design elements in common:

- a main personnel sphere constructed of steel with a diameter of approximately 6 1/2 ft;
- three viewports;
- an oil-filled framework to connect various components, as well as a glass-reinforced plastic fairing;
- a ballast system comprising 3 major sub-systems:
  - (1) hard system in which seawater or oil is pumped in and out of steel spheres,
  - (2) soft system in which compressed air is used to displace water in fiberglass air buoyancy chambers, and
  - (3) emergency lead weight which may be dropped in the event of failures of (1) and (2);

- essentially the same life support system, in which CO<sub>2</sub> is absorbed by a scrubber using either lithium hydroxide or Sodasorb and in which oxygen is supplied from compressed oxygen cylinders;
- propulsion from two 120V DC motors;
- lead-acid batteries, which are pressure compensated in an oil-filled enclosure;
- underwater telephones operating on 27 or 9 kHz and VHF radios used on the surface;
- navigation instruments normally consisting of a compass and scanning sonar; and
- auxiliary tools and equipment that are part of the submersible and, usually, one heavy-duty manipulator and one articulated manipulator.

The SDL-1 has basically the same design, except that the main sphere is connected by an access trunk to a diver lock-out sphere. Structurally this is designed for 1000 ft lock-out operations and 2000 ft nonlock-out operations. TAURUS, through a large increase in displacement, is able to carry additional electric power and compressed gases, making extended missions feasible either in a diver lock-out mode or 1-atm transfer mode. AQUARIUS is a small submersible of cylindrical design with batteries stored in 1-atm cylinders. Both AQUARIUS and TAURUS have large (36" diam.) viewports.

#### Operational History

PISCES I-- PISCES I was launched in 1966 and in the following 6 years, prior to being sold to Vickers Oceanics in England, it was used for a variety of commercial tasks. These included the recovery of torpedoes on a routine, daily basis, a 21-dive mission in the Arctic regions including short excursions under the Arctic ice, and the salvage of two vessels, the EMERALD STRAITS and the HARO STRAITS from depths of 680 and 450 ft. These were 100-ton and 130-ton vessels and the accomplishment of this job, using a submersible without divers, was a historic first.

PISCES II--PISCES II was built under contract for the Vickers Oceanics. Before leaving Canada it recovered torpedoes from 2400 ft, and since working in the U.K. has had tasks varying from excursions into Lock Ness to working in the oil patch.

PISCES III--Hyco built PISCES III for company operations. Its tasks include the missions performed in Hudson Bay related to oil exploration, work on sub-sea wellheads off the Labrador Coast, and the burial of transatlantic cables on the east shore of North America. PISCES III was sold to Vickers Oceanics in 1972, where it has continued to perform similar tasks.



PISCES VI--Built under contract for the USSR PISCES IV ultimately became the responsibility of the Canadian Department of Environment because of political difficulties. PISCES IV is stationed in Victoria and has been conducting oceanographic research in a variety of fields since its delivery in 1972.

PISCES V--The fifth PISCES submersible was built for Hyco and has been primarily engaged in the burial of transatlantic cables off the east coast of Canada. A notable departure from this work was the assistance in the rescue of PISCES III off Ireland. PISCES V is presently working in the North Sea under lease to Vickers Oceanics.

AQUARIUS--Conceived and built as a low-cost observation submersible, AQUARIUS was launched in September 1973 and has spent most of its time in the training of new pilots. However, its most interesting and worthwhile endeavour has been the replacing of guide wires on a subsea wellhead off the coast of Prince Edward Island. This was a very heavy duty and sophisticated work task that had been considered more appropriate to the PISCES type submersible. It was nevertheless attempted and the attempt was successful.

SDL-1--The Submersible Diver Lock-out 1 was built for the Canadian Navy and since its delivery in 1972 has been operating out of Halifax by the Fleet Diving Unit (Atlantic).

The future--The work that will be accomplished by submersibles presently under construction can only be guessed at. Certainly these tasks will be, in part, similar to those already accomplished, but it is equally certain the tasks performed will be extended, primarily into the field of off-shore drilling and production. Future requirements will be for greater endurance, larger payloads, greater battery capacity, and an increase in manipulative ability.

The limitations of small submersibles must be faced squarely. These are primarily in the area of electrical power and payload. However, as one increases electrical power, and thus endurance, problems of personnel endurance begin to play a larger part. It is often said, with reference to the average duration of a submersible mission, that the mission is over when the pilot is too tired to continue. I would estimate that even now this is the case at least 30% of the time. The other major restriction in submersible operations is the problem of the ship-sea interface. Two basically different launch and recovery methods are presently being used. In Canada, the method preferred (by Hyco) has been the ramp-recovery method. The MV HUDSON HANDLER has made recoveries in 10-ft seas with 7-sec periods and 30-knot winds. Recoveries are routine in 8-ft seas with 8-sec periods and 20-knot winds.

Life support systems have not been a restriction in the 1-atm submersible. The primary criteria in any submersible operation is to ensure that the capacity of the system matches the particular conditions of the job. Although there are strict minimum-capacity standards for all operations, it is up to the operator to arrange for larger capacities for specific missions requiring longer endurance or where the possibility of entanglement is greater.

Life support systems in the submersibles built in Canada have generally

been identical. Because of the restricted operations (normally not over 8 hr) the requirements of the system are minimal. O<sub>2</sub> is supplied either at a constant rate or intermittently in order to keep the pressure in the 0.02 to 0.22 region. CO<sub>2</sub> is scrubbed from air using either lithium hydroxide or Sodasorb in order to maintain a CO<sub>2</sub> concentration of less than 1/2%. Emergency breathing capability has normally been supplied through the storage in the submersible of Drager re-breathing units. These are units identical to those used in the mining industry. Environmental parameters such as humidity and temperature have not been a factor in the PISCES submersibles. The cold temperature of the surrounding water has normally produced a good condensing surface inside the submersible to maintain a humidity which, although never pleasant, is at least tolerable. Temperatures also can be handled through adequate clothing. The specific operation of the life support system is described later in this report.

Operation under hyperbaric conditions is of course completely different. The details of this system are beyond the scope of this report and are covered by other Workshop speakers.

Emergency systems in the submersible have occupied a great deal of attention. A number of unavoidable problems must be allowed for in the systems designs. A real danger is the entanglement of the submersible on the bottom. Hyco submersibles, starting with PISCES II have been equipped with jettisonable propulsion systems. In addition, manipulator claws are jettisonable to allow ascent in the event of failure in the manipulator system. Emergency systems should be independent of the systems used regularly and, in most submersibles, this consists of a hand-operated hydraulic system.

Flooding of portions of the submersible is also a very dangerous possibility. This, on a small scale, is relatively easy to handle through the addition of dropable weights, and large-capacity "soft" air tanks for buoyancy. However, where large 1-atm chambers are involved, there is the possibility (as exemplified by PISCES III) of being stranded on the bottom without enough buoyancy to come to the surface. Although many had been aware of this danger before the PISCES III accident, funds were not spent in preparing for it. Since that time, every submersible company in the world has been engaged in the development of emergency recovery systems. One of the major contributions of this workshop committee should be to coordinate these activities and help reduce needless and repetitive expenditures and to ensure that there is a frequent and rapid exchange of design information so that--within the capabilities of the companies and of the submersibles involved--the most suitable system is always available.

Because of the deep operations (5000 ft) off Halifax necessary for the commercial operations undertaken by PISCES V in the burial of transatlantic telephone cables, Hyco was forced into the development of an emergency recovery system. Advantage was taken of the recently introduced, very-high-strength, low-weight lines available from such companies as Philadelphia Resins. In conjunction with a syntactic float and the hydraulic power regularly available in the submersible's emergency system, this line was used to provide a relatively fool-proof, simple means of floating a line to the surface. This

line did not depend on complicated and chancy haul-down or slide-down mechanisms, but instead was in itself a lift line with a guaranteed minimum breaking strength of 12,000 lb; 6000 ft of line is carried. This system is coupled with an air-lift bag system designed to provide enormous buoyancy near the surface to overcome any major flooding possibility and to facilitate recovery by the ramp method. This system is pictured in Figs. VB-1 to VB-4.

Location of any object on the sea floor has always been difficult and it is particularly difficult if an acoustic beacon "pinger" is not available. The PISCES submersibles have almost always carried pingers aboard them and, in fact, underwater telephone specifications have been modified to incorporate a 20-watt pinger to ensure that an adequate signal-to-noise ratio was available. This must be considered the most reliable and fool-proof detection method aboard. It was very unfortunate that the PISCES III did not have such a pinger aboard during its operation.

#### Operation of the life support system - PISCES

There are two operating methods for controlling the carbon dioxide (CO<sub>2</sub>) and oxygen levels within the personnel sphere. Both methods have been used with success and are equally safe.

Method 1--The first method is the most commonly used in PISCES submersibles. The procedure is as follows:

1. Immediately upon entering the submersible with the observer(s), the pilot shuts the hatch, sets the barometer, records the cabin temperature and pressure, and sets the timer to 30-40 min.
2. When the timer goes off, the scrubber is operated for 4-5 min. As the absorbant lithium hydroxide cannister becomes depleted, operating time is gradually increased to 10-15 min. The timer is used to measure scrubber operating time, and reset to 30-40 min after the scrubbing cycle.
3. Immediately after scrubbing, the cabin pressure and temperature are checked and immediate action is taken if a change of pressure cannot be accounted for.
4. Oxygen is admitted to the cabin by opening the shut-off valve on the O<sub>2</sub> bottle to near-maximum flow rate and letting the O<sub>2</sub> flow in until the cabin pressure is back to what it was when the hatch was first shut.

It is important to monitor and take into account cabin temperature during the scrubbing cycle. Heat is generated during the CO<sub>2</sub>-absorption process. This causes the cabin temperature to rise at the beginning of the cycle, thus increasing cabin pressure. The situation reverses later and the pressure drops. The principal disadvantage of this method is that the pilot, having many things occupying his mind, may forget that the O<sub>2</sub> has been turned on, thus bringing the cabin pressure and the O<sub>2</sub> concentration abnormally high. The main advantage is that it compensates for changes in consumption due to changing activities, or differences in an individual's consumption rate.

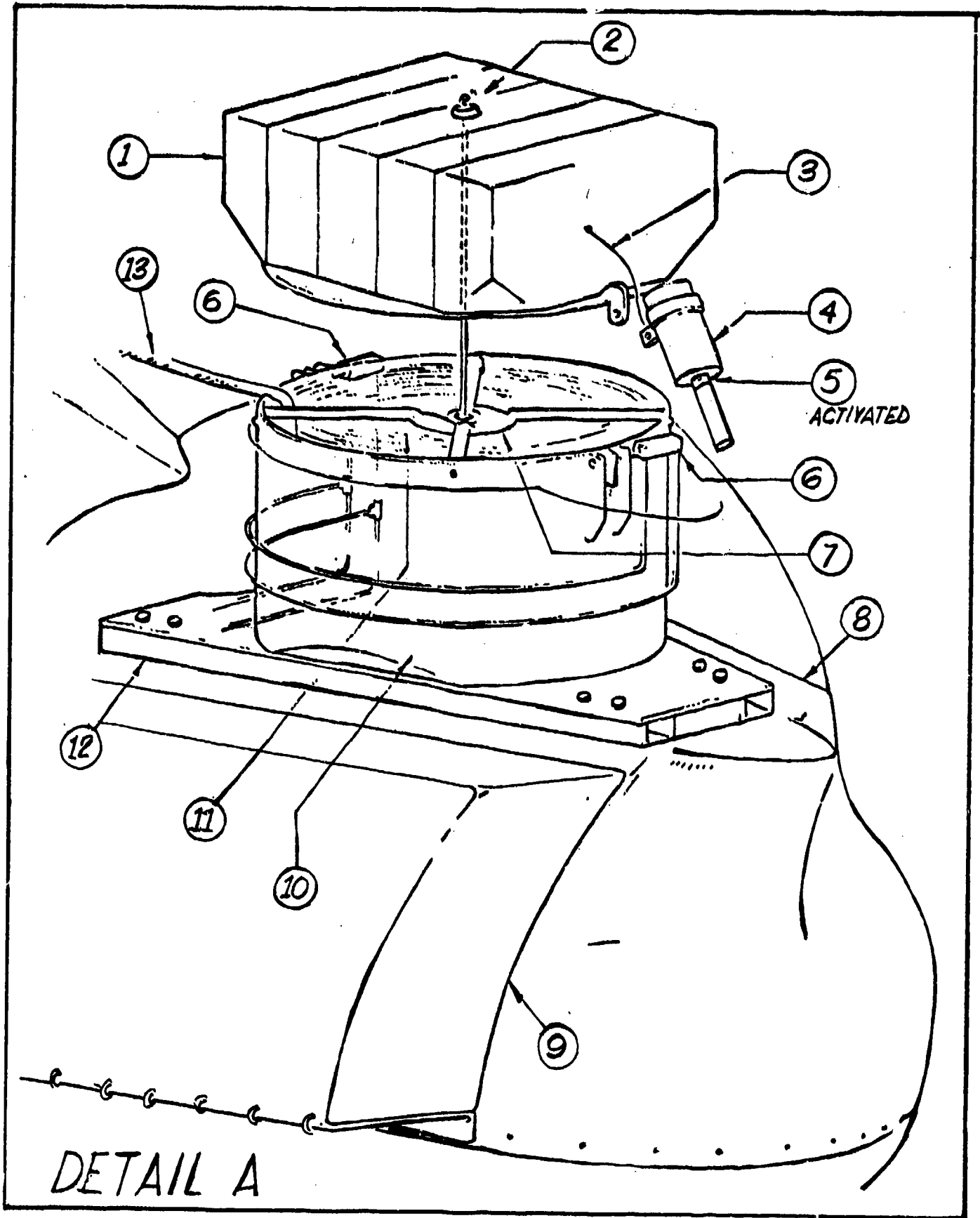

FIG. VB-1

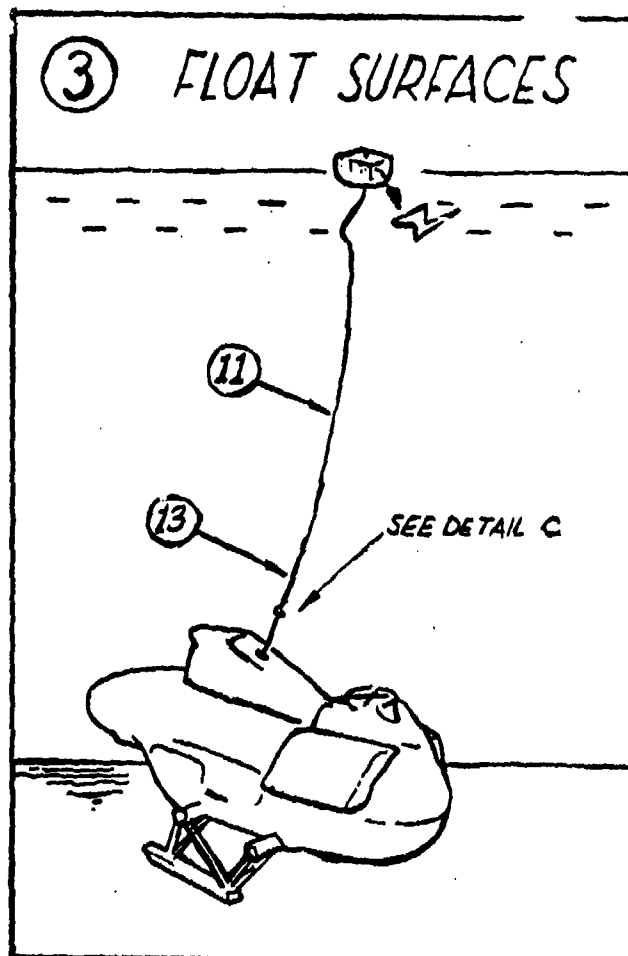
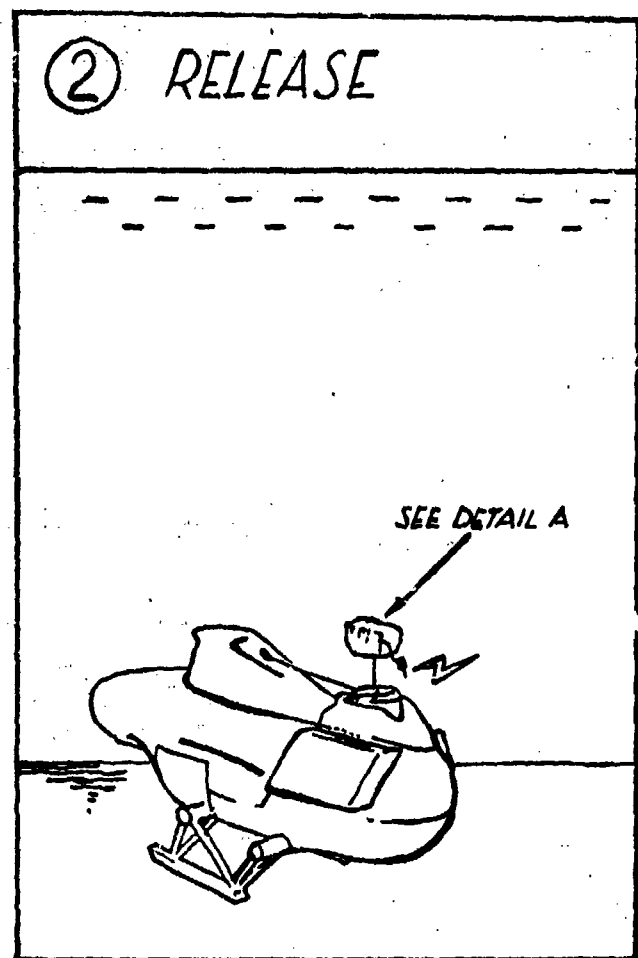
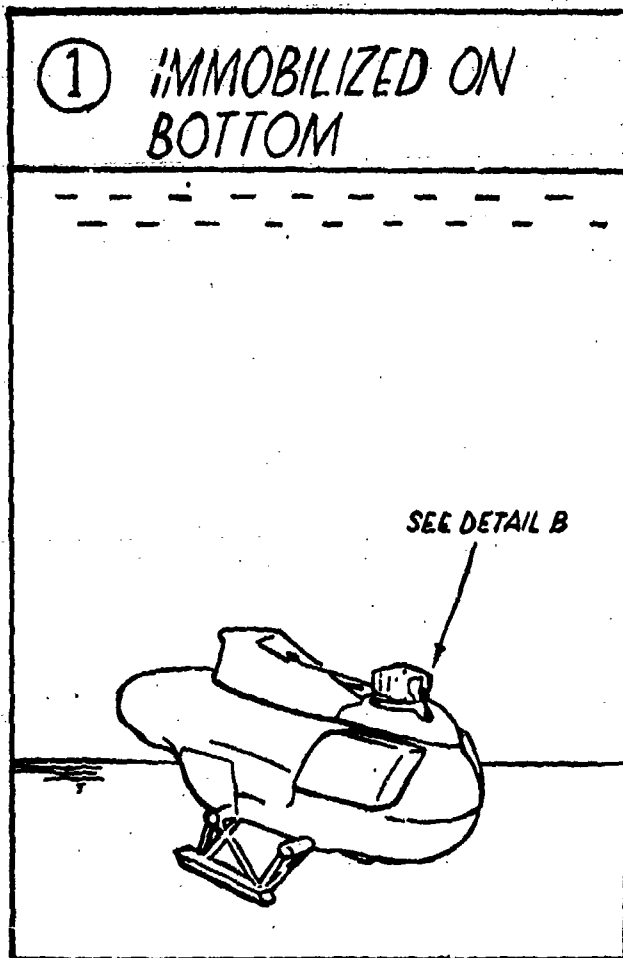

FIG. VB-2

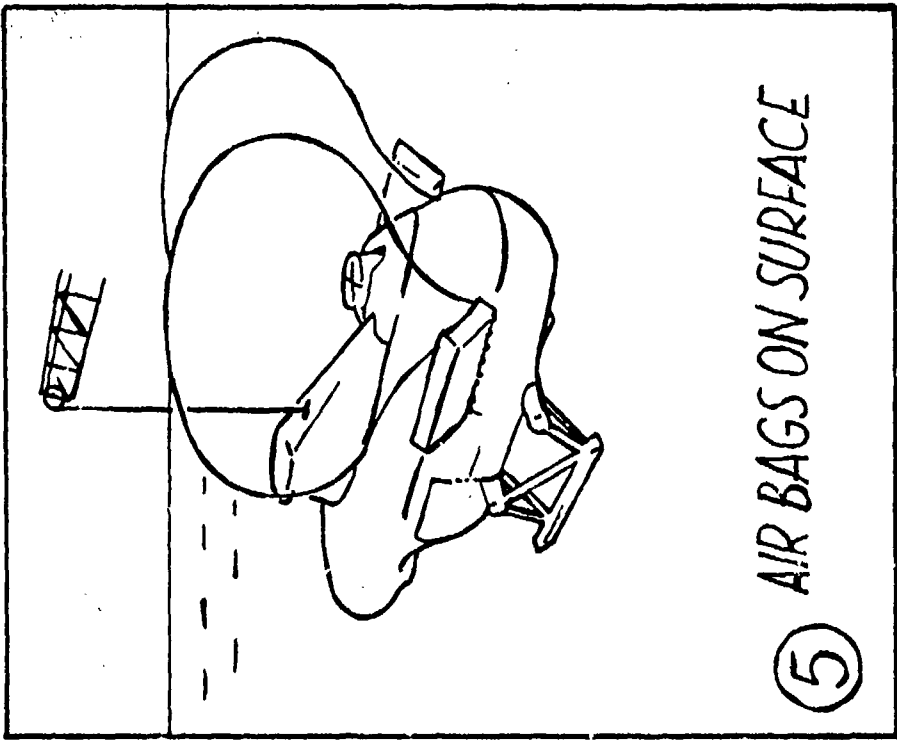
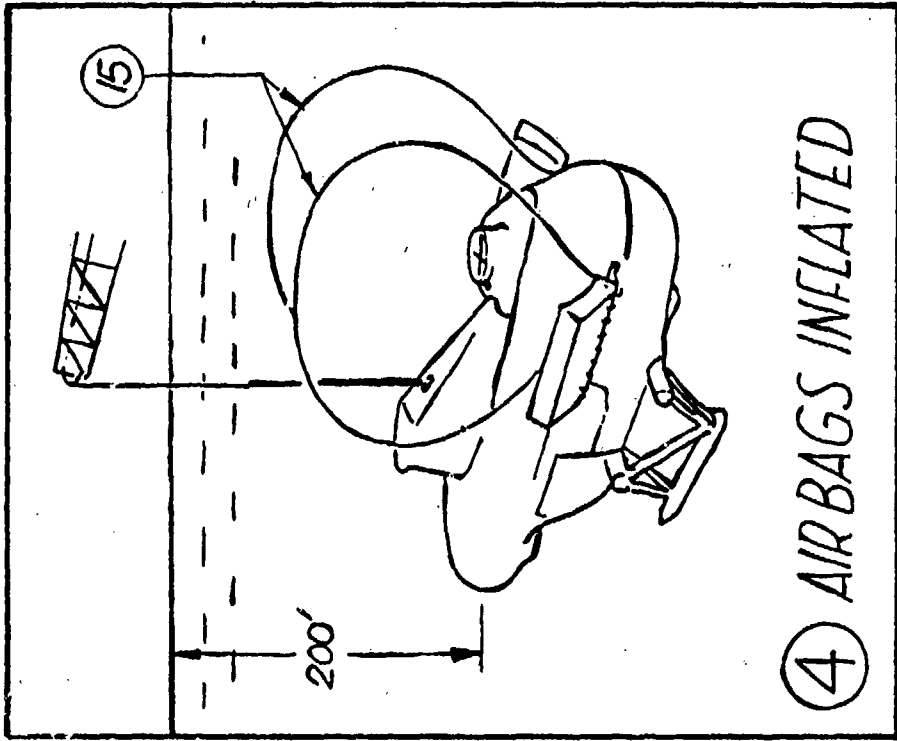

FIG. VB-3

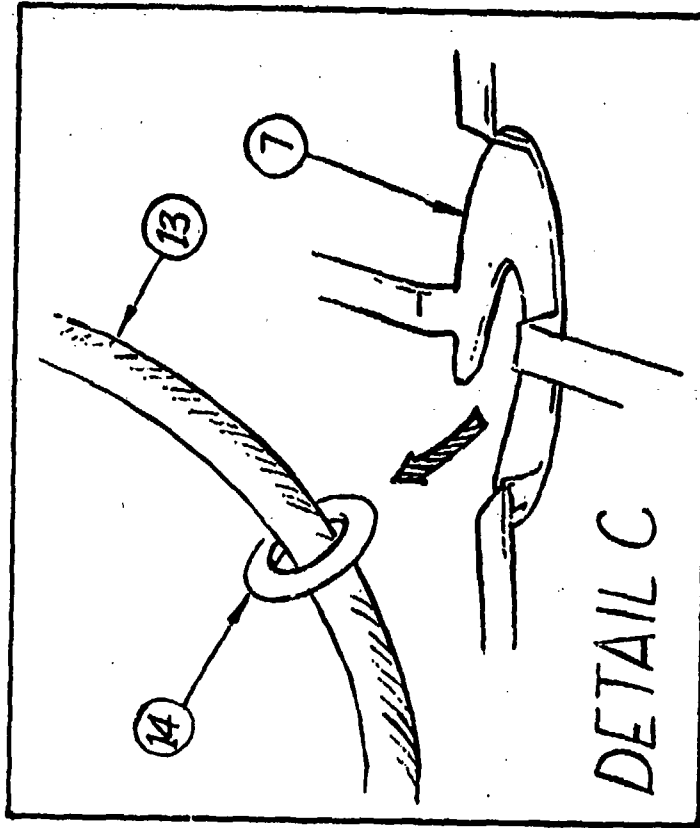
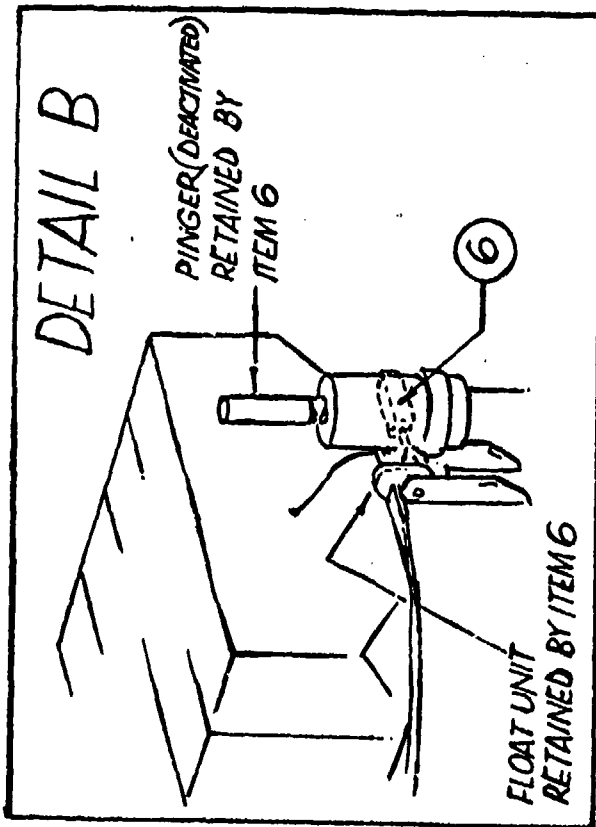

FIG. VB-4

Method 2--The second method of maintaining a suitable environment has been used by Hyco in the past, particularly on SDL-1, and by other operators on submersibles not built by Hyco. The procedure is as follows:

1. Same as Method 1.
2. Turn oxygen on and set the flow rate at 0.40 liter/min per man in the sphere (i.e. 0.8 liter/min for two men). This flow is maintained throughout the dive.
3. Operate scrubber as in step 2 of method 1.
4. Check cabin pressure and oxygen level regularly and adjust O<sub>2</sub> flow accordingly.

During an inactive period, such as while the submersible is being towed, the flow rate can be reduced. On the other hand, during an operation requiring much body movement, the flow rate should be increased. In practice, very little readjustment of the O<sub>2</sub> flow rate is required since the oxygen level may be allowed to vary 1 or 2% above or below the 20% standard.

#### Training

Over 50 pilots have been trained during the last 5 years. The training programs have varied from a very formalized approach to a regular "up through the ranks" approach. Many of the personnel trained have been given a psychological aptitude test. This has not been used as a selection criterion, but rather as a method of accumulating data in the hope that the information would be useful in future selection programs and in sorting out any major personnel problems. The nature of this testing is reported under the next topic. Although not conclusive, the results have been encouraging enough to recommend the use of this test. The teaching guidelines are generally those recommended by the Deep Submersible Pilots Association (DSPA).

Over the years there has been considerable conflict over the desirability of submersible maintainers and pilots being combined. This has been Hyco's approach, although it has not been followed by all our customers, particularly the military. As operating companies grow in size and complexity, maintenance of this dual role may not be possible. However, it is essential that all pilots be familiar with both the theory of operation and the maintenance procedures. All pilots must be maintainers but, unfortunately, the reverse is not always possible, nor desirable. Even within a group of pilots one man will be much better at a particular submersible task than another. The successful field manager will take advantage of this to the benefit of the company and the customer.

#### A summary of methods of testing personnel and trainers of International Hydrodynamics, Ltd. <sup>1/</sup>

In June 1969, a research group at Simon Fraser University were reporting on the physical fitness of individuals, using measured heart rate, ECG tracing, rate of pedalling and load, and heart rate recovery time. The physician

<sup>1/</sup> This summary was provided by Lolita Wilson, Associate Professor, Assistant to the Vice-President, Academic



working with this group was also the Director of the Health Service at Simon Fraser University and he asked for psychological testing of submersible trainees similar to the testing being done with their experimental physical fitness group. The trainees were moved onto location in England almost immediately after the tests were administered and individual interviews were not possible. The assessments were therefore submitted as "blind" analyses with all the reservations appropriate to such procedures.

The tests used were the California Psychological Inventory, which would give some idea of the personal-emotional functioning of the individual, and the Wonderlic Personnel Test. The latter was used not only as a way of testing the general level of intellectual functioning but also as a method of recording whether the subjects worked quickly, accurately, neatly, and according to the printed instructions: a clinical use of a paper and pencil test. Reports were then made on the various individuals as they came through the training program. Several of the subjects were members of the Canadian Armed Forces and it was thought at one time that the Armed Forces would take over the testing program. Follow-up on what these men have done in the past several years, indicates that the tests predicted with considerable accuracy how the individuals would function in terms of working as a cooperative unit and whether they would remain with the project.

During this period, a senior student in psychology did a study of commercial divers using similar tests and a new test called the Chromatic Differential. He was able to describe something of the personality structure of these subjects, each of whom was a successful commercial diver. This information is also available. We now have test results on more than 30 individuals together with pertinent follow-up information.

Without having done a thorough statistical analysis, it would be foolish to make firm comments on the test results. However, it looks as though these tests have been useful as predictors as they were not used for the purpose of selection or posting. The tests were particularly useful in picking out those individuals who would not succeed and indicating the reasons why they would not succeed.

The NARWALL II submersible system for seismic data acquisition under the Arctic ice. <sup>2/</sup>

Arctic Canadian Continental Shelf Exploration System of Access has been developing a submersible seismic system over the past two years. This system comprises a quiet, hydrodynamically clean, Hercules-transportable, 3-man submersible; a precise navigation system; an implosive, no-bubble energy source; modern digital instrumentation, and a 12-group 1/2 mile streamer. This system is designed to provide 1200% CDP coverage under continuous tow at 5 - 5 1/2 knots. It is proposed to operate at a depth of 88 - 100 ft below the ice, and in water depths of at least 200 ft.

The advantages of this submersible system are: (1) the potential productivity of a normal marine system, limited only by the mobility of the surface support and positioning systems; (2) an extremely low noise level

2/ This section was contributed by J.B. Prendergast and A.S. Lee from a report to appear shortly in The Oil and Gas Journal.

recording system; (3) a low-energy and downward directive source well removed from the ice that should eliminate or at least minimize horizontally propagated ice noise (flexure waves, etc); (4) massive recording for high fidelity or "bright spot processing"; and (5) a regular and orderly control grid unaffected by surface ice conditions.

The submersible NARWAL II has been designed by and is being built under the supervision of Bill Rand, Technical Vice-president of Access. Mr. Rand was project director of the BEN FRANKLIN Gulf Stream Drift Mission. Although the vehicle has been designed specifically for seismic work under the Arctic ice, sufficient flexibility has been built in so that, upon the completion of a season's work, the submersible can be used for such things as pipeline route studies with only slight modification. The characteristics of the NARWAL II are as follows:

Length	45 feet
Beam	8 feet
Displacement	57,669 pounds
Airlift weight	41,429 pounds
Speed	5.5 knots
Range	111.5 nautical miles
Reserve	15.0 nautical miles
Max. operative depth	1,000 feet salt water
Endurance	90 man days
Crew	3 men

It has been designed with a fiber glass propeller to minimize electrical noise. The prop has a large diameter and rotates at 60 rpm with only 15 hp. applied to it.

Sea trials are expected to commence in December, 1974, offshore of Florida. Under ice preparations will be made at the Western end of Great Slave Lake, and it is expected that production surveying will begin in April, 1975.

Safety--The 90-man-day life support system provides a large excess safety margin. The vehicle position is known to within a few hundreds of feet at all times by acoustic pinpointing. The two surface vehicles are always from 0 to 30 miles distant and within 0 to 10 hr from the sub's position. A helicopter is also equipped with a complete service module and could go to the scene of the emergency.

To those on surface an emergency situation exists if the seismic source stops firing. This may or may not be true on the submarine itself; for example, any adjustment to the seismic system necessitating shutting the source down would not constitute an emergency. In any event, when the source stops the sub is maneuvered to rest against the underside of the ice and a surface unit sent to its location. Once the vehicle has arrived within the acoustic fix area, an underwater telephone is lowered into the water and voice contact made with the sub crew and emergency procedures are decided upon. If the problem is something that can be resolved on board, then the surface crew stands by until this has been achieved. If it is a problem

that requires outside assistance then a hole is augered near the submarine. The sub would be positioned so that the cylinder could lock on to the hatch, either by using it's own power or--if necessary--be put into position by a team of divers. The main hazards are fire, flooding, and hull rupture.

Fire--The sub is equipped with an auxiliary bib oxygen system which the crew would immediately put on as soon as the warning system indicated fire. Standard submarine fire-fighting procedures can then be used.

Flooding--The hull is sealed completely except for the shaft area and, although there is an inflatable collar on the inside of the shaft entry to the hull, leakage could still develop. There are salt water warning systems in the bilges and a hatch by which the after section of the sub can be inspected. Should flooding develop, the submarine is brought up to the bottom of the ice by flowing tanks or, if necessary, by dropping shot ballast. The crew will pressurize the after compartment to equalize with sea water pressures at that level and effect repairs.

Hull rupture--The most serious of submersible accidents are related to hull rupture due to exceeding the rated depth.

Since the NARWAL will be operating approximately 100 ft below sea level, some 900 ft above its rated depth, hull rupture is a very remote possibility. Nevertheless, should the sub start down, there are some 5000 lb of releasable shot ballast built into the keel section. With an additional 5000-lb buoyancy a sub of this size will rise immediately to the under side of the ice. If it becomes necessary for the crew to abandon, the central section can be pressurized as a lock-out chamber and the energy source removed from the hull; the crew can then don scuba gear and exit the hull through this port.

O.M.I. Arctic navigation system--The navigation system is a time-base system using rated caesium beam atomic clocks standards, a time-differential technique using the low-frequency transmitting stations such as Omega for gross positioning. At a master stationary position on the ice, a minimum of two different low-frequency transmitters are monitored. As long as these transmitting stations are atomic-clock controlled then variations in times of reception of the signals from these stations will be due to variations in the propagations paths of the transmitted signal for whatever reasons. Since it can be safely assumed that within approximately 50 miles between receiving points the same propagation paths errors will be common to all the local caesium clock-controlled receivers. The time differences of the same event being received by the slave stations in relation to the master station therefore represent range when converted to distance using the speed of light. Using four such master and slave units set outside a 40 mile by 40 mile area, then the control for the area within is established. The vehicular atomic-clock receivers are rubidium-clock based with a short-term stability and lesser expense and size as compared to the caesium-clock receivers which have long-term stability and greater size. Because of the short-term characteristic of the rubidium clocks they must be up-dated against one of the caesium clocks periodically. A fifth such clock will be installed in the helicopter used to

transport the crew, and, in the case of emergency, service equipment. Since the helicopter will be at the exit or entry point of the submarine during each crew change or within a 12-hour period, then the submarine clock can be re-rated at this time along with the rubidium clocks in the tracked vehicles. The travelling master clock will also be used to tie the positioning system on the surface of the ice to absolute geodetic points at the nearest land fall.

On board the submarine and other moving vehicles, the same far-distance, low-frequency signals will be received and corrected in the same fashion as those on the surface of the ice. The crew will have a plot of their progress made along track (their position left or right of track as well as the ranges from any two of the surface master or slave points). The sensitivity of the navigation system is one nano-second or 0.9 ft; however, propagation-path unknowns and variations will increase this noise envelope to  $\pm 3$  ft over the surface of the ice and probably  $\pm 50$  ft under the surface of the ice.

Seismic energy source--The Seismovac Monopulse pneumatic rebound Seismic Source has been described in Geophysics (Vol 37, No. 1, February 1972). The principle of operation is as follows:

A cylinder contains a sliding piston which is initially positioned at the open end of the housing. A partial vacuum is created inside the cylinder, and a clamp holds the piston in place against the external hydrostatic pressure. At the firing instant, the clamp is released and the pressure differential accelerates the piston inward. As the piston accelerates inward, its velocity increases and the internal pressure rapidly increases as the gas inside the cylinder is compressed. At some point this compression causes the internal pressure to equal the external pressure and the piston velocity is at a maximum. Due to inertia, the piston compresses the gas to well over the external pressure, and generates a positive pulse of acoustic pressure many times greater than the initial negative wave. The large internal pressure causes the piston to rebound as if driven by a spring. A second down-stroke is prevented by restraining the motion of the piston.

The signature of the signal is considered to be stable and is relatively free of following pulses. The frequency spectrum is all in the seismic range between 10 and 100 Hz. The output and frequency content can be varied by changing the initial pressure differential.

Seismic instrumentation--A set of DFSV digital, floating-point binary-gain instruments will be mounted on the rear bulkhead of the cabin. It is essentially a miniaturized version of the DFSIV's. Twin tape decks will ensure continuous data acquisition. A flatbed, single-channel sequential recorder will complete the onboard instrumentation.

Seismic streamer--The streamer comprises: five 50-m isolation sections, twelve 50-m live sections with acceleration cancelling hydrophones, and depth recording and waterbreak sections. This will give a maximum source-deflector distance of 1/2 mile. The streamer has an outer diameter of 1.1 inch and is connected to the submarine through the propellor drive shaft via a specially designed plug equipped with an hydraulic jettisoning device.

The streamer will be initially balanced with the aid of divers; it will have slight positive buoyancy so that when the sub is at rest the streamer will rise to the bottom of the ice. It is not envisioned that it will be touched except to replace dead sections.

Surface-support system--There are three surface-support service modules - that are fully transportable by either helicopter or tracked vehicle. One of the service modules in the field has a large diesel generator to be used for recharging the batteries at the end of each 31-hour cycle; otherwise the systems are identical. This includes ice augers (a means of putting the cylinder through the ice and latching onto the submarine), mooring devices, underwater communication equipment, and divers. The spare system remains at base camp except for emergencies, for a breakdown of one of the field modules, or for when a helicopter move is dictated by the grid pattern.

Method of operation--The normal cycle for the submarine will be a 9 hr traversing, 1 hr of crew change, another 9 hr for traversing, and 12 hr of battery charge. During this 31-hr cycle some 100 statute miles of seismic data will be acquired.

The basic and most efficient survey traverse for the submarine is 40 miles along dip and 10 miles along strike. This can, of course, be modified to a 45 x 5 or a 35 x 15 or any variation of this sort. The suggestion of a basic 5 x 8 mile survey grid has come up and obviously this fits very well with the 40 x 10 efficient traverse.

With the submarine moored to the service module through the cylindrical trunk, the batteries are charged; the crew is changed; and tapes, supplies, and scrubbers are replenished. Meanwhile the second service module is positioned at the exit point, a 42-inch hole is augered through the ice, and the acoustic and underwater telephone systems are placed. The sub then commences its traverse and the entry point remains on location until it is obvious that the submarine is within the reach of the exit-point station. The entry-point service module then moves to its next location and prepares to receive the submarine back from the previous exit point.

The system of mooring is as follows: when the sub gets within underwater telephone range of the exit hole, it is instructed to position it immediately down current from the exit hole. A small hole is augered a precise distance up current from the exit hole and a mast is lowered. The submarine pilot opens the clam shell at the forward end and also the hatch on the top side, which puts the ice scrubbers in place and exposes the midship transverse thruster. By opening the forward clam, the fore and aft vertical and lateral thrusters at the bow are exposed as well as an arm with a clamp attached. The operator also has lights forward to illuminate the last part of his docking procedure. The submarine then proceeds up current on its thrusters until the mast is grabbed. The midships transverse thruster is used to slowly position the boat with its hatch precisely under the cylinder that has been lowered from above the ice. Once the hydraulic seal has been made, the water is pumped from the cylinder and access to the submarine achieved. The two other masts aft are to hold the submarine so that no torque is applied to

the cylinder.

Conclusions--The described system is expected to produce seismic data of at least comparable quality to that achieved by conventional means.

It has however, two big advantages: high productivity and a regular control grid.

In the first operational season, sorties will be made under the ice pack in the Northern part of the Sverdrup Basin to discover some of the difficulties that may be expected for this type of work. There is no reason to believe that the submersible could not be used to achieve a radial, flower petal-type pattern from a series of locations on the Arctic pack. It may be possible to modify the present approach in some manner by using helicopters so that a rectangular grid could be obtained. The ramifications of success in this direction are obvious: it opens up not only the Northern part of the Sverdrup Basin but also the Beaufort Sea and such other prospective areas for hydrocarbons as offshore Alaska. In addition to its under-ice capabilities it may be that with present power developments such as fuel cells or small nuclear engines that the time endurance of NARWAL can be increased sufficiently to make it competitive for surveying in the rough water areas of the world such as the North Sea and the North Atlantic.

#### SEA OTTER Submersible

Specifications of the SEA OTTER are as follows:

Length . . . . .	1.3 ft	Hatch Diameter . . . . .	19 in
Beam . . . . .	5 ft	Life Support (Max) . . . . .	200 man hr
Height . . . . .	7.2 ft	Total Power Capacity . . . . .	13.8 kilowatt-hr
Draft . . . . .	5.5 ft	Speed (knots) Cruise . . . . .	1 @ 6 hr
Weight (dry) . . . . .	3.2 tons	Max . . . . .	3 @ 1.5 hr
Operating Depth . . . . .	1,500 ft	Crew: Pilots . . . . .	1
Collapse Depth . . . . .	3,650 ft	Observers . . . . .	2
Launch Date . . . . .	1971	Payload . . . . .	550 lb

Pressure hull--Two 0.625 inch thick, section welded, mild steel, hemispheric sections are welded to the ends of a 0.75 inch thick, 57.0 inch long, 48.0 inch wide, mild steel cylinder, with a 0.75 inch thick, 19.0 inch diameter, hatch tower welded in with doubler plates to the pressure hull.

Ballast/buoyancy--This sub is launched positively buoyant. Buoyancy is controlled by two 250-lb main buoyancy air/water ballast tanks and two 62.5 lb forward trim air/water ballast tanks. The tanks are alternately flooded and vented 500 ft<sup>3</sup> @ 3000 psi air flask.

Propulsion/Control--A 3-hp DC Motor drives a 9 x 15 inch propeller for main propulsion. Two 1/2 DC horizontal thrusters, located fore and aft, provide steering along with a hydraulically controlled rudder mounted on the main thruster, which serves as a trim tab for use in cross currents. A 1/2 vertical thruster is mounted forward. All thruster and main propulsion

motors are air compensated.

Trim--Bow angle and fine trim are controlled by hp air and water in either the main or forward ballast tanks.

Power source--Twelve 2-volt, lead-acid batteries provide 13.8 kilowatt-hr. They are located inside the pressure hull and are equipped with catalyzers to eliminate hydrogen.

Life support--Three 40-ft<sup>3</sup> tanks of medical grade oxygen supply the life support system. Scrubbing of CO<sub>2</sub> is accomplished by recirculating through a 6.4-lb lithium hydroxide cannister. Three cannisters provide 192 man-hours of available life support on each dive. CO<sub>2</sub> and O<sub>2</sub> percentages along with atmospheric pressure are monitored. A back-up emergency breathing system, air supply through mouthpieces, is also provided.

Viewing--Four viewports are provided forward for the pilot and passenger, along with two viewports along the side to accommodate reading externally mounted in situ instrumentation. Three viewports are located in the hatch tower, providing 270° of viewing. One viewport is located in the hatch, providing visibility toward the surface.

Operating and scientific equipment--Two underwater communications systems are provided; 27 kHz primary, 42 kHz secondary. A directional gyro compass and a narrow horizontal bandwidth 27 kHz receiving antenna are provided for navigation, along with five air-compensated lights totaling 1.5x10<sup>6</sup> candle power of illumination. Also provided are; external depth and temperature gauges, pressure gauge, a Hydro Products 400-exposure, 70 mm camera and strobe, 16 mm cinecamera with a capacity of 400 ft of film and a video camera along with both audio and video recording capabilities. A 23-channel CB radio is provided for surface communication and DF location. A 27 kHz pinger for location, tracking and diver-submersible rendezvous operations and an upward/downward-looking echo sounder.

Manipulator--The NAR Beaver MKI Manipulator gives all the degrees of freedom of the human arm and hand plus 360° rotation at the wrist and a wrist extension. Additional tools are available and can be provided on the manipulator for specific tasks. An "A" frame which is hydraulically controlled is also provided and is utilized as an attachment point for core samples, cable cutters, collection basket, and many other simple tasks and applications as required.

Safety features--A 200-lb, mechanically releaseable, emergency-ascent weight and a releaseable buoy and messenger line that can be released by the pilot through a hull penetrator are included. A magnesium release pin is used, which will also provide release if the pilot is incapacitated. The messenger line is used to send down a self-locking clamp and lift line. The submersible can be retrieved even if flooded. Eight hours of emergency breathing air is also provided.

Surface-shore support--The sub can be transported by aircraft, ship, truck,

or trailer. It is normally on a trailer and can be launched from a small boat-launching ramp, can be towed at 4 - 5 knots, and tows completely submerged.

### The refitting of the AUGUSTE PICCARD <sup>3/</sup>

The refit of AUGUSTE PICCARD at Horton Maritime Explorations, Ltd., includes the design and installation of ordinary and emergency life support and safety systems. This design is not yet complete and installation has not started. AUGUSTE PICCARD was initially used to carry passengers in Switzerland. Up to 45 persons were carried at a time, the dives lasting about an hour. The free-air volume within the boat was sufficient for the number of people for this time period to keep the carbon dioxide level below 1% without any air treatment. Between dives the boat was flushed with a high capacity blower. Emergency life support equipment consisted of 7 bottles of medical oxygen of 50-liter capacity, each at 200 kg/cm<sup>2</sup> pressure and of soda lime through which a fan forced the ambient air. The complete system was designed for 90 man-days of life support; it never had to be used. A head with a holding tank was present for human waste elimination; this was rarely used.

An emergency drop-weight system consisting of iron shot in hoppers equipped with magnetic valves was installed in the main ballast tanks. This system similar to those used on other Piccard-designed submersibles, is quite effective if fresh shot is used for each dive; repeated surfacing and diving causes the shot to rust together, however, and the system becomes unreliable.

AUGUSTE PICCARD was operated in 1973 and 1974 on a test basis without much change in the configuration it had in Switzerland. The major change was the substitution of solid-lead emergency ballast release weights for the iron shot system. The new system used manually operated hydraulic actuators as the ballast-release mechanism; the system never had to be used in practice but it worked well in tests. The existing emergency life support system was checked out but never used. The longest dive was of 5-hour duration, with nine men aboard; even though smoking was permitted at times, the carbon dioxide level stayed below 1% without any air treatment.

During one operational period AUGUSTE PICCARD was used only periodically. In the nonoperational intervals the temperature inside the hull approached ambient water temperature (about 45°F in the winter) and the relative humidity approached 100%, with consequent precipitation of moisture. During operations, electrical power dissipation and crew body heat caused the internal temperature to rise 20° to 25°F and the relative humidity to fall to about 85%.

The refit will accommodate a live-aboard crew of six. (Additional people can be carried on a short term, or "hot bunk", basis.) The fresh and waste water systems plus the head installation have been redesigned. A head-shower combination is being designed. A day-in, day-out operating sequence of 14 hours submerged and 10 hours surfaced for charging is envisioned. Normally, with six men aboard, the contained boat air will suffice. However, with additional passengers, longer submergences, or in the event of an emergency, air treatment will be required. Passive lithium hydroxide panels will be used

<sup>3/</sup> This section was contributed by D.J. Morecombe.



for carbon dioxide removal. An immediate emergency (flooding, fire, and smoke) breathing system will also be installed.

Heat, not cold, will be the main problem during operations due, mainly, to electric power dissipation and heat stored in the batteries during charging. Air conditioners will be installed to keep the engine room below 90°F while the diesels are running (surface only) and to keep other areas comfortable with respect to temperature and humidity at all times.

### Conclusion

The submersible industry in Canada, as in the rest of the world, is very customer oriented. Submersibles cannot be designed or built in a vacuum. The end use should be defined before construction begins. This is the major challenge presently facing both manufactureres and operators. What problems will be encountered tomorrow? Who will the customer be? What will he want to do? Where will he want to do it? A lively and creative imagination is tremendous asset in any area of the submersible business, whether you are a potential user or a supplier.

## C. THE SUBMERSIBLE PROGRAM IN FRANCE: F. DREYER

Deep diving research submersibles from France and the United States have embarked upon a three-year international scientific program, called FAMOUS (French-American Mid-Ocean Undersea Study). They will make a detailed study of a submerged mid-Atlantic ridge which lies 200 miles south of the Azores, which has not yet been studied at close range. The study is expected to furnish direct knowledge of how the earth's continents and oceans were formed, information that bears directly on the formation of metallic ore deposits and oil accumulation.

The submersibles have collected samples and emplaced instruments on the ocean floor to provide a continuous supply of precise data on the dynamics of sea floor spreading and the emergence of new crustal material.

Following two years of site surveys and training, a fleet assembled on site in the summer of 1974. The French bathyscaphe ARCHIMEDE and French submersible SP-3000, the U. S. ALVIN, and four surface ships carried out the most extensive deep ocean manned submersible study ever undertaken.

Each of the deep-diving research vehicles had special assignments to make best use of their differing capabilities. The SP-3000, which has a high degree of maneuverability, was used for rapid visual reconnaissance and for studies within the rift valley of the mid ocean ridge. ARCHIMEDE, a bathyscaphe designed for maximum depths and heavy payloads but in relatively gentle terrain, explored the fracture zones of the sea floor.

A special training program was designed for the scientific divers. This included practice dives in all submersibles, field trips by divers and pilots to Iceland and Eastern Africa where similar terrain is located, and workshops for establishing priorities on the types of observations to be made during the various dives. Navigation and sampling instrumentation were developed that are interchangeable among the submersibles. Materials that follow describe ARCHIMEDE's scientific devices.

### ARCHIMEDE SCIENTIFIC EQUIPMENT <sup>1/</sup>

#### Technical Description of ARCHIMEDE Navigation System

##### Basic system

The system includes:

- ship                    one transceiver, four channels  
                          one transducer in a tonned fish  
                          one calculator  
                          a classical surface-navigation system

<sup>1/</sup> This section on ARCHIMEDE was contributed by J.F. Drogou, A. Farcy, J.L. Michel and D. Semac.

- submarine one special transponder
- two to four transponders (See Fig. VC-1)

Preliminary step: transponder calibration--After launching transponders according to a relief-compatible geometry, a transponder array survey determines the relative positions of the transponders as accurately as possible.

Step I: Ship localization and submarine distance--Initiated at time  $t_0 = 0$ , the ship interrogates (16 kHz) the  $n$  transponders and the submarine transponder, so we have

$$\rho \times t_a = 2 d$$

$$\rho t_{bn} = 2 D_n$$

Step II--The submarine transponder, after a precise delay, emits a delayed interrogation (16 kHz) toward other transponders; the answer is demodulated by the ship, so we have:

$$\rho t_{cn} = 2 (d + d_n + D_n)$$

By calculation we have on the ship in X,Y system the coordinates of the ship and the submarine.

#### FAMOUS results at 3000 depth

The FAMOUS navigation was made in very sharp terrain. In 1973 and 1974, 60 transponders were moored. Three transponders commonly were used, forming an equilateral triangle with 3000 to 4000 meters sides and 2500 to 3000 meters immersion. Because of the terrain, transponders were 150 m above the bottom; occasional surface reflexions were manually calculated with good results. Between the 1973 and 1974 surveys one transponder was lifted as a marker.

Estimated accuracy--This ship had a navigation radius of 10 m for a station. The submersible had a navigation radius of 10 m for a station.

#### 6000 M extension

The array specifications are the same as described above. The precision of the submersible localization, according to the degree of improvement chosen, may be estimated between 5 and 30 m.

#### ARCHIMEDE Sampling Equipment

Telemanipulator--The telemanipulator has one hydraulic arm, 8 degrees of freedom; it can lift 150 kg at its maximum elongation. Opening of the claw is 280 mm. It works at 6000 m depth (components tested at 10,000 m) and has two baskets with two compartments for sample collecting.

Tools--The hydraulic arm can operate various tools, such as sediment corers,

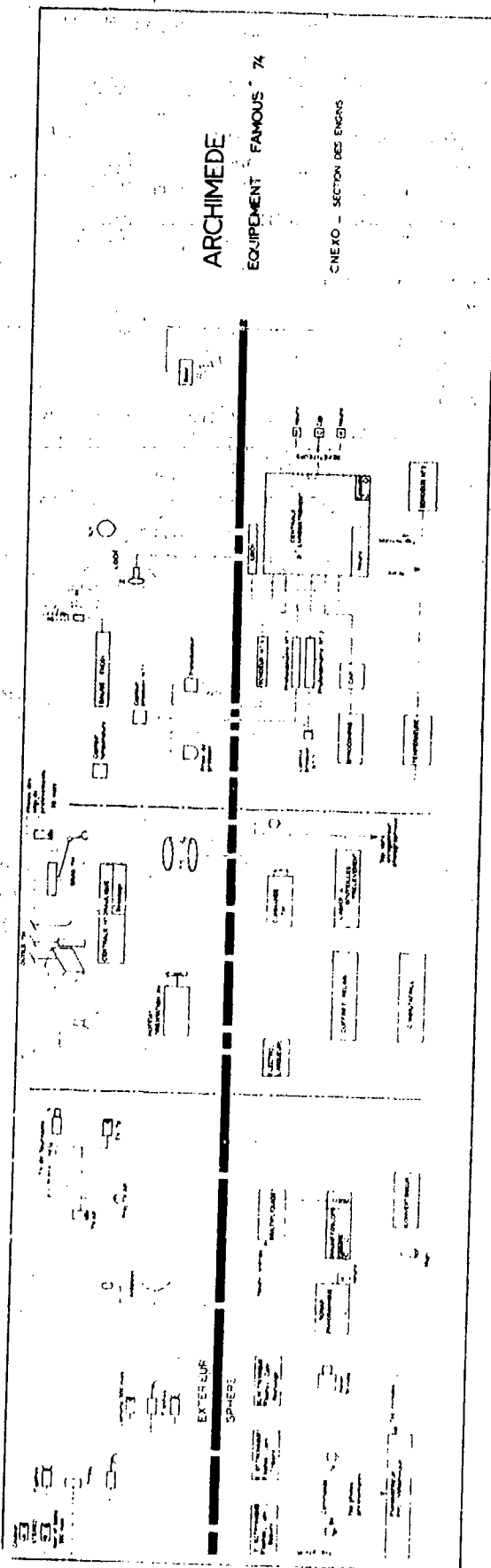

Fig. VC-1. General diagram of ARCHIMEDE's scientific equipment.

sample nets, geological tools, etc.

Water sampling system--Twenty water bottles (0.5 liters) can be taken on each dive.

### Description of ARCHIMEDE Photographic and T.V. System

#### Photographic system

The time of every shot is recorded in two independent ways on the photo itself by a clock and in the submarine sphere on a synchronized recorder.

Port--The port system is composed of two 500-shot, 35 mm Edgerton cameras, a stereo set, and three flashes. At 1.30 m from the ground, the two cameras photograph the bottom. The camera axes are bent 15° from the horizontal line and 30° from the ship axis (field 36° x 27° in water).

Starboard--The starboard system is composed of a 500 shot Edgerton camera and two flashes. At 2 m from the ground, the camera photographs the bottom. The camera axis is bent 47° from the horizontal line and 45° from the ship axis (the field is common to the starboard viewport).

Front--At the front a camera can photograph the samples taken by the sampling arm. It can make 20 shots without any flash, under beams.

#### T.V.

The T.V. system is composed of three T.V. cameras, one at the back; one starboard, in the same position as the photo camera; and one at the front in the axis of the submarine. These T.V. cameras are at high resolution (10 MHz) and high sensibility. A computer can choose the camera that will be seen on the monitor and recorded by the video-cassette recorder of the sphere (band with 2,7,MHz). A digital display enables one to see and record the time of the date-logging system on the screen.

### Description of the Existing System of Data Acquisition and Analysis of ARCHIMEDE

Data: pressure, temperature, heading, altitudes

Two pressure captors and their electronics work independently and continually with an accuracy of 0.5%, and a resolution of 1 meter. A silistance captor measures the temperature--resolution 0.003°. A platinum probe captor has a resolution of 0.001° and an accuracy of 0.1°C between 0° and 20°C. A precision digital echo-sounder has an opening of the beam 15° at 3 dB and a resolution of 1 m at a range of better than 70 m. A captor and an electronic repeat the heading with an accuracy of 1°.

#### Magnetic data logging system

Eight parameters are recorded: time, pressure<sub>1</sub>, pressure 2 or temperature (platinum probe) or altitude, heading, temperature (silistance), and three

available analog inputs. The clock of this data-logging system sends synchronization impulses to the recorder of the Furumo echo sounder. Three displays are drifted from this data-logging system to repeat the time twice and the heading once. The time is also drifted and mixed to the T.V. frame. The eight parameters are recorded every 10 sec on a mini-cassette (15 hr can be recorded on one cassette).

Analysis of data--A rack enables the quick restitution of the recorded parameters (eight parameters recorded in 10 hr are restituted in 1 hr).

#### Miniatures photographic recorder

The following discrete parameters are recorded: minute marks of the main clock, marks of port side photo, marks of starboard photo, and marks of the camera photographing the sampling. A simple development system enables to get the information of one dive in 1 hour.

#### Navigation devices which can give scientific information

A panoramic sonar with a range of 500 m on passive echo describes the shape of the surrounding landscape, even of its nature for a qualified operator. The picture on the oscillograph is photographed on a 35 mm camera in the same time as the time of the main clock. A second echo sounder, recorded on paper, gives the altitude; its range is 300 m on flat bottom. The minute marks coming from the main clock are recorded on the same paper.

D. THE SUBMERSIBLE PROGRAM IN JAPAN: H. ISHIKURA

The postwar scientific undersea submersible program in Japan began with KUROSHIO built in 1951. The submersible was built by Nippon Kokan KK for the Faculty of Fishery of the University of Hokkaido as a diving observing chamber for marine biological studies in shallow waters around Hokkaido. Subsequently, it was equipped with a propulsion system for movement underwater. Since launching, she has actively been engaged in the observation of fishing grounds, fish habitats, and general seabottom conditions; collection of plankton and other samples; photograph of plankton, fish, and fish nets; testing of underwater oceanographic instruments; and geological studies of the seabottom including the site proposed for the construction of an undersea tunnel connecting Honshu and Hokkaido. She was very active during 1952-54 and again during 60-63 and by 1971 she had completed more than 700 dives. In 1970 she was completely rebuilt and the major characteristics are described in Table VD-1.

Table VD-1  
The characteristics of the KUROSHIO

Length overall (from extreme point of arm to aft end of Vertical rudder)		11.8 m
Width		2.2 m
Depth (from bottom of platform to upper deck)		2.25 m
Depth overall (from bottom of platform to top of hatch)		3.2 m
Draft (surface condition)		1.9 m
Diameter of pressure hull (out side)		1.5 m
Weight in air		12.5 tons
Maximum operating depth		165 m
Crew		5 men
Durability	5 men	24 hr
Propeller (3-blade solid type)		1 unit
diameter		800 m
revolution		290 rpm
motor	AC 400 V 3 phase 60 Hz/ 7.5 KVA	
Speed (submerged)		ab. 2 kts
View port		
diameters		3 of 160 mm 7 of 120 mm 6 of 60 mm
Steering gear		
Diving plane		bow 1 Stern 1
Rudder		1

Table VD-1 (continued)

Ballasting system		
(a) ballast tanks		
capacities	fore	240ℓ
	aft	180ℓ
drain pump	25kg/cm <sup>2</sup> x 27 ℓ/min	1
(b) main tank		
capacity	ab. 1500	x 4
high pressure air flash	150 kg/cm <sup>2</sup> x 40 ℓ	x 2
Life support system		
Fan (100V 100W)		1
Carbon dioxide absorber		1
High pressure oxygen flask	150kg/cm <sup>2</sup> x 7ℓ	x 3
Training chain		
Diameter		30 mm
Length		5 m
Hand hoist		1
Electric supply cable		
Diameter		36 mm
Length		600 m
Composition	3 phase power cable telephone line x 2 TV coaxial cable communication line tension member (9 mm steel wire)	
Power transformer		
3 phase 60Hz 10 KVA		
primary		400 V
secondary		200 V, 100 V
Navigation and observation equipment		
Depth guage (10 m x 1, 200 m x 1)		2
Clinometer		1
Echo sounder (consists of 3-transducers; upward, downward, forward)		1
ITV camera and monitor		1
Seawater leak detector		1
Flood light (100V 100W)		5
Interior lighting (10W)		3
Telephone (for communication with mother ship)		1
Photographic equipment		1
Hand-operated sounding machine		1
Fathometer		1
Tidal current meter		1
Azimuth finder		1
Emergency equipment		
Aqualung		5 sets
Life jacket		5
Mask		5
Fire extinguisher		2



Following KUROSHIO, two small submersibles christened HAKUGEI and YOMIURI were built; the first by Heiwa Kosakusho for Tokyo Salvaging KK and the second by Mitsubishi Heavy Industries for Yomiuri Newspaper KK. HAKUGEI, built in 1961, is a work submersible for various investigations and small scale civil engineering operations in water to the depth of 200 meters. However, her recent activity is not reported. YOMIURI was owned and operated by the newspaper company in the interest of science. Following her launch in 1964, she was used for the collection of deep sea fish and corals, photographing and video-recording of the seabottom for mass communication on the continental shelves around Okinawa, Australia, and other parts of the Pacific. However, she was grounded on the shore of Hachijo Island in October 1970 during a typhoon and ultimately abandoned.

Table VD-2

YOMIURI

Endurance (hr)	Propulsion		Life support	
	6 @ 4 knots		24 Normal	48 Maximum
Length, LOA, (ft)	48.5	Air weight, dry. (lb)	77,900	
Beam (ft)	8.2	Submerged display actual, not molded (lb)	82,300	
Height, (ft)	9.2	Payload (customer) (lb)	1,900	

Operating depth: 100 ft

Crew, operator(s) + observer/passenger

3 + 3

Pressure hull	High tensile steel, 0.63 thick; welded cylinder, hemihead aft, dished head fwd; 6.75ft dia. x 30.8 ft conning tower amidship	Hatches, number, position, and inside diameter, (in)  View ports, number, position, and small diameter, (in)	1.25 dia. amidship  3, 4.7 dia. 4, 2.36 dia.
---------------	--	--	---

Manipulator

Hydraulic/mechanical arm fwd.

Vertical lift (lb) 110

Main power source	Type	Battery: lead-acid Diesel engine	Description  25 hp. 900 rpm diesel/electric aux. diesel for battery charging; alternator for ac load, 50 cell, 450 A-hr, battery, 100 V, dc, 45 kW-hr.	
	Make	Mihon Denchi Mitsubishi		
	Air weight (lb)	Battery: 4770 Diesel: 1680		
Propulsion	Number of units and location	Single propeller at stern	Motor(s) and propeller	2 diesel engines. 1, 12-kW 100 V-dc motor, 1000 rpm. Drives reduction box for stern propeller, 3-blade, 33.5 in dia.

Table VD-2 (continued)

Speed, (knots)	2 Cruise	4 Maximum
Maneuvering	Manual control of rudder and diving plane located aft of propeller, 3 sea water tanks, 6000 lb, four main buoyancy tanks, 17,720 lb. Blow with 1780 psi air in 5 cylinder, 19.5 ft.	
Emergency features	Two droppable keels, 1760 lb water weight, total. Access trunk to be used as escape trunk; 6 sets of scuba gear carried.	
Support vessel	Surface ship TAKUSEI MARU. Gross tonnage 162 (metric)	

SHINKAI, built in 1969 by Kawasaki Heavy Industries for the Science and Technology Agency has been operated by the Maritime Safety Agency ever since her launching, (see Tables VB-3, 4, and 5). Having a depth capability of 600 meters, she has been employed for undersea scientific investigations, testing of undersea instruments and other purposes by a number of government agencies and research institutes. Through the end of 1973, she made a total of 182 dives covering 475 hours and 37 minutes. Most of her dives were conducted off the coast of western half of Japanese Archipelago.

Table VD-3  
Characteristics of the SHINKAI

1. Principal Dimension		
Length overall		15.3 m
Width		5.5 m
Depth (from bottom of keel to top of super structure)		5.0 m
(from bottom of keel to top of sail)		7.0 m
Draft		4.0 m
Displacement	ab.	85 tons
Diameter of pressure hull (fore and aft sphere)		4.0 m
Maximum operating depth		600 m
Crew		4 men
	(Pilots	2 men)
	(Observers	2 men)
Speed (Submerged)	Maximum	3.5 kts
	Normal	1.5 kts
(Surface)	Maximum	3.5 kts
(Towed)	Maximum	5 kts

Table VD-3 (continued)

Endurance	at maximum submerged speed	3 hr
	at normal submerged speed	10 hr
Life support		48 hr
2. Main Equipment		
Main propulsion motor		11 KW 1
Auxiliary propulsion motor		2.2 KW 2
Battery, preserve in oil bath		2000 AH
Main propeller		1
Auxiliary propeller		2
Ballasting system (main ballast tank)		1 set
	flooding and blowing system)	
	(auxiliary ballast tank	1 set
	flooding and blowing system)	
	(trim tank	
	flooding and draining system)	1 set
Trim pump	DC 100V 0.75 KW	1
High pressure air system		1 set
Life support system		1 set
Air cooler	DC 100V 0.75 KW	1
Dehumidificator	AC 100V 200 W	1
Hatch	I.D. 500 mm	4
	I.D. 600 mm	1
View port	effective diameter 120 mm	3
	50 mm	2
Trailing chain (chain device for soft landing at sea floor)		1
Hydraulic system	DC 100V, 3.7 KW	
	operating pressure 105 kg/cm	1 set
Flood light	500 W	7
	Do 100 W	10
Ballast jettisoning device		1 set
Automatic tank blow system		1 set
Rescue capsule		1
Bilge level alarm system		1 set
Life saving system, life jacket		4
Fire extinguisher		1
3. Navigation and Observation Equipment		
Gyrocompass (with repeater 1 set)		1
Speed meter (vertical and axial direction)		2
Depth gauge (one self-recoring type)		4
Clinometer		3
Balometer		1
Clock		1
Altitude and depth sonar		1
Obstacle avoidance sonar (upward, downward, forward)		1
Listening sonar and pinger (dropable)		1
Underwater telephone		1
Emergency underwater telephone		1

Table VD-3 (continued)

VHF radio	1
Transponder	1
Interphone	2
Thermometer	1
Flash light	1
Manipulator	1
Plankton net	3 sets
Sea water sampler	1 set
Sediment sampler	2 sets
Underwater television (2 cameras with pan mechanism)	1 set
Sound speed measuring equipment	1 set
Bottom current meter (thermister type)	1 set
Salinometer	1 set
Salinity, temperature, depth meter	1 set
Transparency measurement	1 set
Seismic profiling system	1 set
Radiation measurement (scintillation counter)	1 set
Heat flow measurement	1 set
Magneto meter	1
Tape recorder	1
Under water camera (stereo type still camera x 2 movie camera x 1)	1 set

Table VD-4  
Diving activities of SRV SHINKAI since launching

Year	Number of days dived	Number of dives	Total hours		Sea area
1968	2	4	4 h.	37 m.	Training
1969	34	60	101	28	Off Komatsujima Off Kannoura
1970	19	22	78	48	East and western section of Sagami Bay, Off Chofu and off Kannoura
1971	33	38	121	14	Western section of Wakasa Bay, off Kannoura
1972	23	23	77	06	Off Kannoura
1973	30	35	103	18	Off Ito and Yura

Table VD-5  
Diving activities of submersible SHINKAI in 1973

Date	Operation	Sea Area	Agencies	Number	Depth
May 1	Put to sea				
May 7	Test dive	Kannoura	Maritime Safety Ag.	2	102 m
June 2	Test dive	Kannoura	same	5	405
June 4	Landed				
July 19	Put to sea	Off Ito	same	2	430
July 16	Test dive	same	same	1	315
	Inspection of under-sea cable	same	Radio Regulatory Bureau	1	385
	Seabottom gravity m.	same	Geographical Survey	1	205
	Test photography	same	same	2	116
	Observation of layer	same	Hydrography Department	3	536
	Biological observation	same	Fishery Ag.	2	522
	Sediment study	same	Industrial Sci. Tech. Ag.	2	416
Sept. 19	Landed				
Oct. 31	Test dive	Off Yura	Maritime Safety Ag.	1	67
	Biological study	same	Fishery Ag.	3	91
	Undersea camera test	same	Hydrography Department	2	85
	Sediment study	same	Industr. Sci. Tech. Ag.	1	70
	Seabottom gravity measurement	same	Hydrography Department	2	83
Dec. 23	Landed				

Very recently the former Captain of the SHINKAI, Mr. Kato published a detailed report on his experience during the operation of this submersible and specified the modifications which he deemed necessary. Among these, the following are considered the most important.

(1) Environmental control in the hull--Although the air supply system was originally designed to be sufficient for three dives to the maximum depth, two dives are considered the appropriate limit because of the need to reserve air for blowing water out of the ballast tank should this become necessary.

The environmental control capacity was designed to sustain four men for 48 hr, but taking the possibility of an emergency into consideration, each dive should be limited to 5 hr. The capacity of the air-circulating system should be checked with reference to the uniform distribution of oxygen, and efficacy of the canister for removing carbon dioxide, and of the moisture removing system.

(2) Capacity of batteries--It was found that almost one-third of the total electricity was consumed by each dive. Accordingly, the batteries should be charged every two dives, since charging after each dive would have an adverse effect on the batteries.

(3) Outer view--Although a clear view forward is obtainable through the central window as far as the illuminating light reaches the view was limited to just below the bow at proximity. Diagonal view through right and left windows was remarkably dark. Through these two windows both the forward view and view of the seabottom were hard to obtain and this proved very inconvenient for maneuvering the submersible near the seabottom. The simultaneous observation of the same object through the central window and either side window was also difficult unless the observers took a cramped attitude.

(4) Horizontal movement--In order to maneuver the SHINKAI keeping a given depth and course for more than 10 min, the power of the main thruster should be used at less than half of the maximum, thus reducing the practical maximum speed 1.2 knot/hr. When observations are made, the forward movement should be slowed down less than 30 cm/sec or 0.6 knot/hr. At greater speed the submersible is liable to pass over the object to be observed, sampled, or photographed, and if backward thrust is exerted, the abrupt change of thrust agitates the mud on the bottom, increasing turbidity.

(5) Pre-dive preparation--As the number of operating and supporting crews are limited, at least a whole day is required between dives for preparation. In order to make more frequent operation feasible, the following augmentation of instrumentation and the support system are considered necessary.

- More precise positioning system.
- An additional hydrophone line.
- Modification of support ship or construction of new support ship.
- Depth determination system with accuracy of 50 cm.
- Distance determination in horizontal direction with accuracy of 5 m.
- Intensification of illumination.
- Enlarging of observation window.

In the late 1960s, anticipating the growing needs of undersea operations in connection with the construction of offshore installations, an undersea tunnel and other offshore facilities, exploration and exploitation of offshore oil and gas fields on the Japanese continental shelf and undersea cable and pipe line settings, a number of enterprises were undertaken to deal with undersea operations employing either submersible or diving technics. Nippon Kaiyo Sangyo KK (former Ocean Systems Japan) ordered a submersible from Kawasaki Heavy Industries. The submersible, completed in 1971 and named HARUYO, can

dive to the depth of 300 meters with a crew of three. It was designed for the inspection and setting of undersea cable, pipeline and the bottom-set tunnel, completion of undersea oil wells and inspection thereof, civil engineering operation for the foundation and surveying on the seabottom (see Table VD-6).

Table VD-6  
The characteristics of the HAKUYO

Length (overall length)	6.4 m
Width (maximum)	1.6 m
Depth	2.0 m
Draft	1.9 m
Maximum operating depth	300 m
Displacement	6.6 tons
Number of crew	3 men
Speed	Maximum 3.5 knots
Endurance	5 hours at 1 knot
Life Support (for 3 men)	48 hours
Principal Equipment	
Main propulsion motor	10 PS x 1
Horizontal thruster motor	0.5 PS x 1
Vertical thruster motor	0.5 PS x 2
Main propeller rotating device	1 set
Diving plane	1 set
Ballast tank flooding and blowing system	1 set
Auxiliary and negative tank flooding and draining system	1 set
Trim control system	1 set
View port	Inner dia. 150 mm x 4
Hydraulic system	1 set
Battery pod detaching device	1 set
One point attaching device (for lifting)	1 set
Main battery	110 V x 100 AH
Auxiliary battery	24 V x 100 AH
Flood	2
Gyro compass	1 set
Depth sonar (for upward & downward)	1 set
Obstacle avoidance sonar (for forward)	1 set
Underwater telephone	1 set
UHF radio	1 set
Manipulator (hydraulic)	1 set
Underwater breathing apparatus (for 3 men)	1 set
Flash lamp	1 set
Transponder	1 set
Underwater camera	1 set

Since HAKUYO can be transported on board the support ship, in contrast with SHINKAI which is only towable, she has been employed in many parts of the seas around Japan including those off Okinawa and Taiwan. In 1973 she made a total of 69 dives in Sagami Bay, off the coast of Okinawa,

Wakayama Prefecture, Bonin Island, Izu Peninsula and Kagoshima Bay. The maximum depth reached was 250 meters.

In 1970, Mitsui Ocean Development and Engineering Company and Mitsui Ship Building and Engineering Company undertook the development of a tethered lock-out submersible in collaboration with Japan Ship's Machinery Development Association, aided by a subsidy from Japan Ship Business Promotion Association. This submersible was intended for the support of air-diving operations in shallow water not deeper than 100 meters. The submersible can move and hover in water with current up to 2 knots/hr.

Table VD-7  
Characteristics of the TADPOLE-1

<u>Tethered type diving chamber</u>	
Length	5.3 m
Width	3.5 m
Height	3.2 m
Displacement	7.2 t
Maximum operating depth	100 m
Dv. diver support	50 m
Crew	2 men
Endurance of diver operation	4 h
Life support	48 h
Speed	1 kt

The submersible, named TADPOLE, (see Table VD-7) was completed in 1971. The sea trial was conducted in February of the following year and the engineering achievements and problems were identified. In 1973, partial reconstruction was made in order to meet the problems and the lock-out and lock-in tests, with divers, were carried out with success to the depth of 40 meters.

In 1971, Nippon Kokan KK also undertook the development of a tethered submersible jointly with the Japan Ship's Machinery Development Association. The submersible was completed in 1973, and christened UZUSHIO (see Table VD-8).

UZUSHIO has a peculiar pressure hull the lower half of which is made of acrylic resin for increased viewing power. The first sea trial was conducted in October 1973 and partial reconstruction was made. Since the spring of 1974, the submersible has been operated by the Fuyo Ocean Development and Engineering Company, a catamaran-type research vessel of the company, Wakashio, serving as support ship. During the course of training the cabin caught fire due to electric malfunction and two men were killed. The cause of this accident is under investigation by the Maritime Safety Agency and the result has not yet been announced. Possibly the leakage of electricity occurred in a cable connector that was immersed in sea water, causing the burning of the insulating materials of the cable, consuming oxygen in the hull and generating toxic gas.



Table VD-8  
 Characteristics of the UZUSHIO

Maximum operating depth		200 m
Operational current (maximum)	ab.	2 kt
Crew		2 men
Height		2.94 m
Width		2.92 m
Displacement (submerged)		5.6 t
Weight		5.2 t
Diameter of Pressure Hull		
Upper hemisphere		1.94 m
Lower transparent hemisphere		1.50 m
Life support	2 men x	48 h
Electrical power supply cable		500 m
Propulsion system		
3-hydro-jet	5.5 KW x	3
Operational duty		8 h/day
Classification		NS* SUBMERSIBLE

In 1969 the Ocean Science and Technology Council, an advisory body, submitted to the Prime Minister a Report on the Development Program of Ocean Science and Technology and a proposal was made for the building of a submersible which has a depth capability of 6000 meters.

Anticipating the promotion by the government agency of this proposal, Japan Ship's Machinery Development Association launched a comprehensive 5-year project to develop more important components of a submersible of such capability. The implementation of this project has received the cooperation of major shipbuilding and related industries, and a great deal of progress has been made.

In 1973, the Science and Technology Agency launched a study of the feasibility of building such a submersible and the implementation of the study was assigned to the Japan Marine Science and Technology Center. Information was collected and reviewed concerning the following:

- Survey and comparative investigation of deep sea surveying systems.
- Safety standards.
- Positioning systems.
- Observational systems.
- Conceptual designs.
- Basic plan of the submersible.
- Basic plan of the support ship.

The study is expected to be completed in 1975.

E. UNDERWATER ACTIVITIES IN THE SOVIET UNION: LEE H. BOYLAN

The presentation on the Soviet Union was basically an attempt to provide an overview of the historical milestones and state of the art of undersea research vehicle (URV) development and operation by the Soviet Union. In addition, information relating to planned URV development was presented.

Since the time of the Workshop in November 1974, two interesting items of information have come to light. The first of these involves a statement appearing in a 1973 diving manual in which the Soviets claim an early record in deep diving. Although not much has been written about deep saturation diving by the Soviet Union, some insight is provided by a recently published diving manual. In 1935, a group of physicalians headed by Academician L. A. Orbeli began investigating the use of helium as an additive to diver breathing mixtures. By 1946, a number of saturation dives to 200 m had been made. The next few years saw the development of heliox diving equipment and a tethered lock-out bell with a DDC mating capability. In 1956, research dives to 300 m were made by a number of divers. It is pointed out that it wasn't until 6 years later that Hans Keller reached the 300-meter mark.

The second item from a recent newspaper discloses the fact that the Soviet Union's most sophisticated URV, the Sever-2 had a mishap during a dive in the Black Sea. During a routine ascent, the vertical propulsion motors began to strain and excess water was noted in the variable ballast tank. A blown static converter caused loss of lift propulsion and began to rise again. After a 12-hr ordeal, Sever-2 was finally brought aboard the support ship R/V Odissey

Based solely on the information used for the report, the following points stand out:

1. undersea-vehicle and support-system design is dominated by Giprorybflot Institute, a fisheries-technology design organization;
2. the past and current inventory of Soviet undersea vehicles belongs almost exclusively to fisheries-research organizations;
3. with exception of a modified fleet submarine, the Soviet Union apparently does not operate any lock-out vehicles;
4. with the exception of conventional submarines used or modified for research, the Soviet Navy does not operate free-diving undersea rescue or research vehicles;

5. there is no evidence of any preorganized rescue capability or equipment specifically intended for undersea vehicle rescue and recovery; and
6. there is no evident research or design interaction between the Soviet Navy and fisheries-oceanography organizations in the area of undersea vehicle and support-rescue development.

The first two points are accomplished fact; however, the following points do not seem reasonable. Lack of published information on these four areas makes any conclusions on any specific Soviet capability in these areas difficult and puts any analyst in the position of having to make gross extrapolations or assumptions.

In reviewing the literature used to compile this paper, the conspicuous lack of detailed information on URV safety-related topics became very evident. There apparently is no available Soviet equivalent of the Marine Technology Society's Safety and Operational Guidelines for Undersea Vehicles or any other major Western work dealing specifically with safety, rescue, and accidents. It would be both naive and unfair to conclude from this that the Soviets have no particular interest in these areas. On the contrary, while they themselves may not be writing much on these areas, it can be easily demonstrated that they have a thorough awareness, professional knowledge, and domestic availability of Western information published on these topics.

In the literature reviewed for the presentation, only one reference (with the exception of the above) to accidents was made. These accidents apparently involved amateur-built minisubs and it is not known whether any of these accidents involved loss of life. The medical literature and aerospace literature do contain a useful volume of information on diver accidents, diver physiology, diver medical problems, and lifesupport systems (spacecraft). The first three are discussed only in terms of free diving. Analysis of Soviet free-diver accidents generally concludes that inadequate training (sport-diver accidents) and/or panic are the two major factors ultimately contributing to accidents. Several of the Soviet habitat programs have involved medical and physiological research (generally, for depths not exceeding 45 meters) and some of the results have been published.

There has been an obvious lag in Soviet URV development for the scientific community. The reasons stated for this are many, but will not be reviewed extensively here; however, a contributing factor, which produces an "accordion" effect, has been the high cost of designing, building, and maintaining specialized URV support vessels and systems. Taking URV development costs, support ship development costs, and the cost of developing a non military specialized rescue capability, we see not only a major financial commitment but a major science-policy commitment to manned-vehicle undersea research. To date, the Soviets have been hesitant to make this commitment on any scale even approaching the Western URV boom of the late sixties. Therefore, the small number of operational Soviet URV's must, for the time being, rely on

the existing capability, which obviously resides in the Soviet Navy and probably to a less sophisticated extent with the Soviet merchant-fleet salvage organizations. These capabilities are little publicized.

Almost all the articles and references pertaining to the specific manned vehicles described mention the availability of various types of safety systems --solid ballast jettison, shot release, etc. However, with very few exceptions, the makeup, operation, reliability, and testing of these systems is not discussed. Available surface support and rescue systems are described somewhat more specifically, but their capabilities and adaptability to crew/vehicle rescue in a URV accident are unknown. In articles describing the operational Sever-2, no mention is made of any surface search and rescue capability, either aboard R/V Odissey or available on short notice. Judging from the open literature, only the Krab TV and manipulator-equipped remote-controlled platform could reach a distressed Sever-2 at her maximum depth and be useful in a rescue.

The best insight into some specific safety and lifesupport systems is provided by Soviet patent literature. Review of the patent abstract journal over the years has revealed a number of patents specifically applying to URV's and habitats, and many others which could apply or be adapted.

Due to the size, scope, and uniqueness of the original, it was felt that wider distribution of the complete document would be of benefit to the interested scientific and engineering community. The 137-page report with an extensive bibliography is available from the Undersea Medical Society at \$2.50 per copy.

## SUMMARY OF DISCUSSION

The work that will be accomplished by submersibles presently under construction can only be guessed at. The tasks presently performed will be extended primarily into the field of offshore drilling and production.

It was felt that one of the major contributions of this workshop should be to insist on coordination of the development of emergency recovery systems to help reduce needless and repetitive expenditures and to ensure that there is frequent and rapid exchange of design information to ensure that the most suitable system is always available.

In the late 1960's, anticipating the growing needs of undersea operations in connection with the construction of offshore berths, undersea tunnels and other offshore facilities, exploration and exploitation of offshore oil and gas fields on the Japanese continental shelf, and undersea cable and pipe line settings, a number of enterprises were established to deal with undersea operations, employing either submersibles or diving techniques.

There has been an obvious lag in Soviet underwater research vehicle development. A contributing factor has been the high cost of designing, building and maintaining specialized URV support vessels and systems. To date the Soviets have been resistant to making a major financial commitment in this area.

## CONCLUSIONS AND RECOMMENDATIONS

### 1. United Kingdom

At present Vickers Oceanics Limited is the only owner and operator of manned submersibles in the UK. Two UK unmanned submersibles ANGUS and CONSUB are operational. ANGUS has its own ability to navigate. CONSUB is utilized mainly for geological research work. CUTLET, an unmanned recovery vehicle similar to CURV, is being developed by the UK Ministry of Defense. V.L. has four submersibles operational, one of which is a lock-out boat. Three support ships make up the other half of these submersible system. One of these has a deck decompression chamber. More submersibles and support ships are on the way in the near future. VOL's main market area appears at this time to be cable burial and pipeline survey.

### 2. Canada

There are four companies in Canada manufacturing and/or operating submersibles. These are Hyco, Arctic Marine, Horton Maritime Explorations and Access. Hyco has built seven submersibles and has five more under construction. Arctic Marine has SPA OTTER. Horton Maritime Explorations own AUGUSTE PICCARD and BEN FRANKLIN. Access has in the development stage, an under-ice submersible called the NARWALL II which will be used initially for seismic data acquisition. The requirements of newer submersibles will be for greater endurance, larger payloads, greater battery capacity and an order of magnitude increase in their manipulative ability. Hyco has developed an emergency recovery system which floats a high strength line to the surface. It also incorporates an air life bag system near the surface. The submersible industry in Canada and the rest of the world must anticipate tomorrow's requirements, i.e., who will the customer be, what will he want to do and where will he want to do it, in order to define the end use of the vehicle before construction begins.

### 3. France

The chief current French submersible activity centers around the French-American Mid-Ocean Underseas Study (FAMOUS), in which the French bathyscaphe ARCHIMEDE and the submersible SP 3000 are working together with the U.S. submersible ALVIN in exploring the mid-Atlantic reidge 200 miles south of the Azores.

### 4. Japan

The submersible program in Japan consists of past and present operations, and studies on future development of submersibles with much greater depth capability (6000 meters).

5. USSR

The Soviet Union undersea-vehicle and support-system design appears to be oriented to fishery technology. With the exception of conventional submarines the Soviet Navy does not operate free-diving undersea rescue or research vehicles. With the exception of the modified fleet submarine, the Soviet Union apparently does not operate any lock-out vehicles. There is no evidence of any preorganized rescue capability or equipment specifically intended for undersea vehicle rescue and recovery.

## BIBLIOGRAPHY

- Anonymous. Novel submersible design from Dutch company. *Hydrospace* 3: 38-39; June 1970.
- Anonymous. Canada lock-out sub completed. *Hydrospace* 3:36; 1971.
- Anonymous. Lock-out submarine in action. *Meerestechnik* 3:50; Apr. 1972.
- Anonymous. Unmanned arctic research submersible successfully tested by Navy. *Nav. Res. Rev.* 25:31; Sept. 1972.
- Anonymous. One-atmosphere diving suit passes tests for deep water. *Ocean Ind.* 8:26-28; Aug. 1973.
- Bailey, V.R., J. La Cerda and J. F. Manuel. Diver lockout and observation submersible: a perspective of participation in offshore operations. In: 1972 Offshore Technology Conference, May 1-3, Houston, Texas. Preprints, Vol. 1. Published by the Conference.
- Blair, W.C. Human factors in deep submersibles. In: *Marine Technology 1970*. Preprints, Vol. 1. Washington, D.C., Marine Technology Society, 1970.
- Booda, L. L. Navy has new unmanned deep ocean vehicle. *Undersea Technol.* 14:11; Feb. 1973.
- Borgarov, N. Deep-sea scout. *Sea Frontiers* 12:95-97; Mar./Apr. 1966.
- Boylan, L. H. Recent Soviet developments in undersea technology. *Mar. Technol. Soc. J.* 6:41-43; Sept./Oct. 1972.
- Bryant, W. R. Codes and regulations affecting the design and construction of human occupancy pressure vessels. In: *The working diving 1974*. Washington, D.C., Marine Technology Society, 1974.
- Busby, R.L. Diver, submersible or instrument package? *Underwater J.* 4:115-123; June 1972.
- Church, R. French deep diving vehicles. In: *Marine Technology 1970*. Preprints, Vol. 1. Washington, D.C., Marine Technology Society, 1970.
- Daniell, A. F. Progress of the Cammell Laird Sea Bed Vehicle. In: *Proceedings of a meeting of the Society for Underwater Technology, Ltd.*, London, April 1970. Published by the Society.
- Danilov, I. Underwater research in the USSR. *Sea Frontier* 18:274-280; Sept./Oct. 1972.
- Dawson, J. W. Vehicle development and operations - Europe. In: *Marine Technology 1970*. Preprints, Vol. 1. Washington, D.C., Marine Technology Society, 1970.
- Eastaugh, R. W. Diving support for manned submersibles. In: *Diving applications in marine research*. Proceedings of a seminar, National Institute of Oceanography, Godalming, Surrey, UK, December 1971. Published by the Institute, 1972.
- Foster, J. J. The case for a towed underwater vehicle for fisheries research. *Trans. Inst. Mar. Eng.* 84: 218-222; 1972.
- Fugitt, R. B. Small remotely-manned vehicles. In: *Ocean 73, 1973 IEEE international conference on engineering in the ocean environment*. IEEE publ. 73-CHO-7740-OCC
- Gillen, H. W. International standards designed for offshore operations. I. Diving submersibles. In: *Proceedings of the Ninth Annual Conference of the Marine Technology Society, 1973*. Published by the Society, Washington, D.C.



- Gruver, J. A. and J. A. Pritzlaff. Undersea vehicle operations and development in the United States. In: Marine Technology 1970. Preprints, Vol. 1. Washington, D. C. Marine Technology Society, 1970.
- Haigh, K. R. Future electronic instrumentation for submersibles, habitats, and divers. Radio Electron. Eng. 41:225-236; May 1971.
- Haigh, K. R. Propulsion of submersibles. Underwater J. 5:53-61; Apr. 1973.
- Haigh, K. R. Submersibles in Europe: offshore oil will be biggest market. Offshore Serv. 6:36-37, 49-50, June 1973.
- Henson, G. S. PISCES III accident. Vickers Oceanics Ltd. Dec. 1973.
- Janousek, J. A. Use of mock-ups in the design of the Deep Submergence Rescue Vehicle. Hum. Factors 12(1): 63-68; 1970.
- Jones, R. E. Support systems for undersea vehicles. Astronaut. Aeronaut. 7:50-55; Apr. 1969.
- Kruger, P. [To coral harvest with the submarine]. Meerestechnik 4:12-15; Feb. 1973.
- Lee, K. J. V. Underwater submersible navigation - Meerestechnik 3:122-128; June 1972.
- Marine Technology Society. Safety and operational guidelines for undersea vehicles. Published by the Society, Washington, D.C., 1968.
- Molland, B. and A. Kensett. How SHELF DIVER and SOUTH SHORE recovered the ELF platform. Hydrospace 4:38-41; Oct. 1971.
- Natural Environment Research Council. A report on the research applications of the submersible Pisces II. Series C, No. 2. London, Published by the Council, 1970.
- Parker, F. A. and J. F. Burt. An integrated life support system for habitats, bells and submersibles. In: Equipment for the working diver. Washington, D.C., Marine Technology Society, 1970.
- Parrish, B. B., E. F. Akyuz, J. Anderson, D. W. Brown, W. High, J. M. Peres and J. Piccard. Submersibles and underwater habitats: a review. Underwater J. 4:149-167; Aug. 1972.
- Paterson, M. R. and A. Rossfelder. Application of manned submersibles to geophysical surveying in the Arctic. Can. Petrol. 12:43-49; July 1971.
- Penzias, W. and M. W. Goodman. Man beneath the sea. A review of underwater ocean engineering. New York, Wiley Interscience, 1973.
- Piccard, J. Inner space. Deep submersible vehicles. Architect. Des. 29: 216-220; Apr. 1969.
- Pritzlaff, J. A. Deepstar 20,000. In: Marine Technology 1970. Preprints, Vol. 2. Washington, D. C., Marine Technology Society, 1970.
- Pritzlaff, J. A. Submersibles submersibles submersibles. Oceanol. Int. 5:38-43; June 1970.
- Pritzlaff, J. Submersible safety through accident analysis. Mar. Technol. Soc. J. 6:33-40; May/June 1972.
- Proctor, M. Marine research in Sweden. Meerestechnik 2: 38-43; Apr. 1971.
- Putman, J. F. Submersible vehicles for the UK continental shelf. Underwater Sci. Technol. J. 2:197-203; Dec. 1970.

- Riffaud, C. J. From bathyscaphes to ARGYRONETE, the French man-in-the-sea program. In: Marine Technology 1970. Preprints, Vol. 2. Washington, D.C., Marine Technology Society, 1970.
- Sasaki, T. On underwater observation vessels in Japan. In: Marine Technology 1970, Preprints, Vol. 1. Washington, D.C., Marine Technology Society, 1970.
- Saunders, W. Submersibles as sample-collecting devices and as possible platforms for in situ experiments. In: Brauer, R. W., ed. Barobiology and the experimental biology of the deep sea. North Carolina Sea Grant Program, University of North Carolina, 1972.
- Shenton, E. H. Where have all the submersibles gone? Oceans 3: 39-56; Nov./Dec. 1970.
- Shenton, E. H. Diving for science: The story of the deep submersible. New York, U. U. Norton and Co., Inc., 1972.
- Stevens, R. C., Jr. The lock-out submersible. A new dimension for the working diver. In: Equipment for the working diver. Washington, D. C. Marine Technology Society, 1970.
- Sweeney, J. B. A pictorial history of oceanographic submersibles. New York, Crown Publishers, Inc., 1970.
- Talkington, H. Why man? U. S. Naval Undersea Center, Feb. 1973.
- Talkington, H. R. The U. S. Navy participation in the rescue of the Pisces III. Mar. Technol. Soc. J. 8:63-67; Jan. 1974.
- U. S. Coast Guard. Study on underwater safety. Appendix B: Safety regulations of manned, non-military undersea vehicles. May 1969.
- Yastrebov, V. The "CRAB" remote controlled underwater craft. Underwater J. 5: 117-119; June 1973.

## LIST OF ATTENDEES

Capt. P. G. Linaweaver Workshop Chairman	COMSUBDEVGRU ONE
Lcdr. D. A. Hall, MSC, USN Workshop Coordinator	COMSUBDEVGRU ONE
Capt. R. C. Bornmann, MC, USN	Naval Medical Research and Development Command
Cdr. R. L. Sphar, MC, USN	Naval Submarine Medical Research Laboratory
Cdr. I. Cruickshank, USCG	U. S. Coast Guard, Hdq.
Cdr. D. Walsh, USN	Fellow, Woodrow Wilson International Center for Scholars
Cdr. J. Vorosmarti, MC, USN	Exchange Officer, U. K.
Lcdr. K. Greene, MC, USN	University of Pennsylvania
Lcdr. R. Biersner, MSC, USN	Naval Education and Training Support
Lt. T. Neuman, MC, USNR	COMSUBDEVGRU ONE
Mr. H. Pass, B. Eng., C. Eng., M. I. Mech. Eng.	Vickers Oceanics, Ltd.
Mr. L. Shumaker	Woods Hole Oceanographic Institute
Dr. H. Ishikura	Japan Marine Science and Technology Center
Dr. J. B. MacInnis	Undersea Research, Ltd.
Mr. M. MacDonald	International Hydrodynamics Co., Ltd.
Mr. L. H. Boylan	Informatics, Inc.
Mr. F. Dreyer	CNEXO
Dr. A. Muren	Navy, Sweden
Mr. J. A. Pritzlaff	Westinghouse Oceanic Division
Dr. D. A. Youngblood	Harbor Branch Foundation Laboratory

Mr. H. R. Talkington

Mr. F. A. Parker

Dr. H. Nakayama

Cdr. J. Onnermark

Lcdr. J. Cole, C.F.

Lt. B. Martin, C.F.

Mr. Y. S. Li

Cdr. T. Uekusa

Capt. R. Worthington, USN (Ret.)

Dr. T. Ishihara

Dr. B. Anderson

BTCS M. Wilson, MSDV

U. S. Naval Undersea Center

Biomarine Industries

Japan Marine Science and  
Technology Center

Navy, Sweden

Fleet Diving Unit (Atlantic)

DCIEM

Lockheed Undersea Division

Japan

Lockheed Ocean Laboratory

Mitsubishi Heavy Ind., Ltd.

Oceanautics, Inc.

COMSUBDEVGRU ONE

V.49